

fundamentos de representación

cuaderno de trabajo

Pedro Gispert Fernández

fundamentos de representación

cuaderno de trabajo

Arq. Pedro Gispert Fernández



Editorial
Pueblo y Educación

Este libro,
en tus manos de estudiante,
es instrumento de trabajo
para construir tu educación.
Cúidalo.

Edición: Lic. Alfredo López Llera
Diseño: Elena Faramiñán Cortina
Ilustración. Arq. Pedro Gispert Fern.

© Pedro Gispert Fernández, 1987
© Editorial Pueblo y Educación, 1987

EDITORIAL PUEBLO Y EDUCACIÓN
Calle 3ra. A No. 4605, entre 46 y 60,
Playa, Ciudad de La Habana

SNLC: CU 01.43111.0

1.4.2.0 CONSTRUIR EN LAS SEIS POSICIONES POSIBLES LOS DIBUJOS ISOMETRICOS DE UN PRISMA RECTO DE BASE RECTANGULAR CUYAS TRES DIMENSIONES SON : 1 x 2 x 3 cm.

- a) DEJAR INDICADAS TODAS LAS CONSTRUCCIONES CON LINEAS CONTINUAS
- b) LINEAS FINAS PARA LAS CONSTRUCCIONES
- c) LINEAS GRUESAS PARA LOS RESULTADOS (ARISTAS VISIBLES)

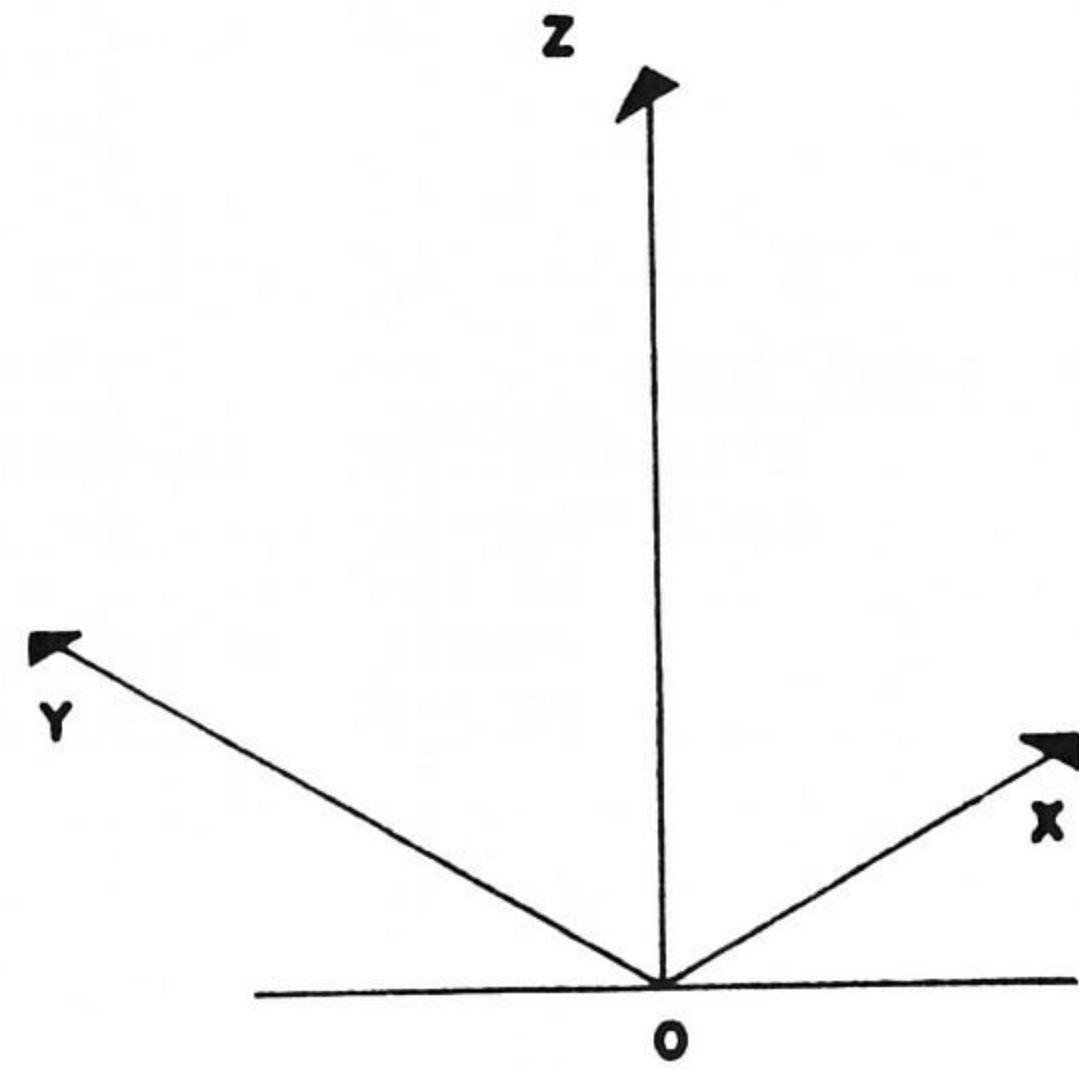
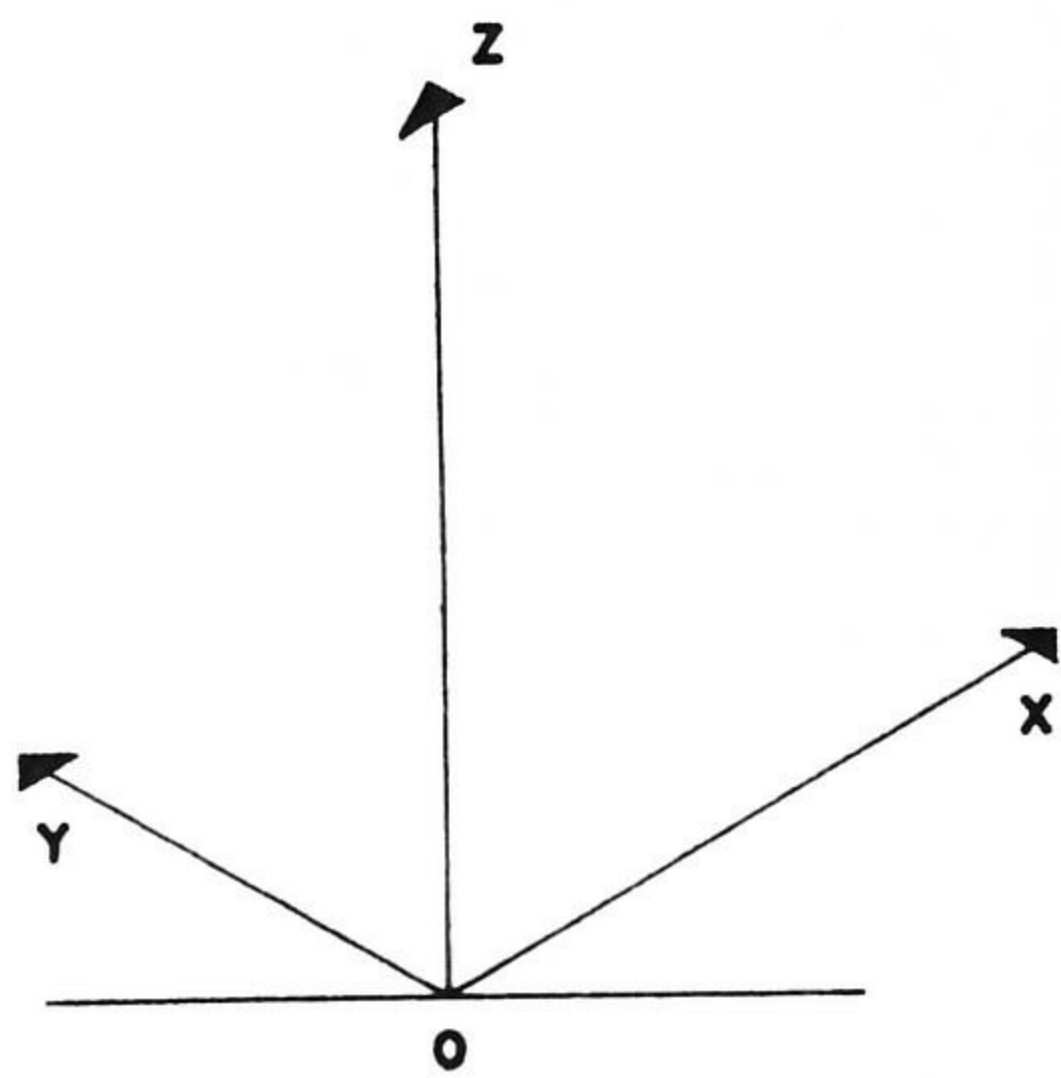

CONSIDERANDO LA ALTURA = 3 cm

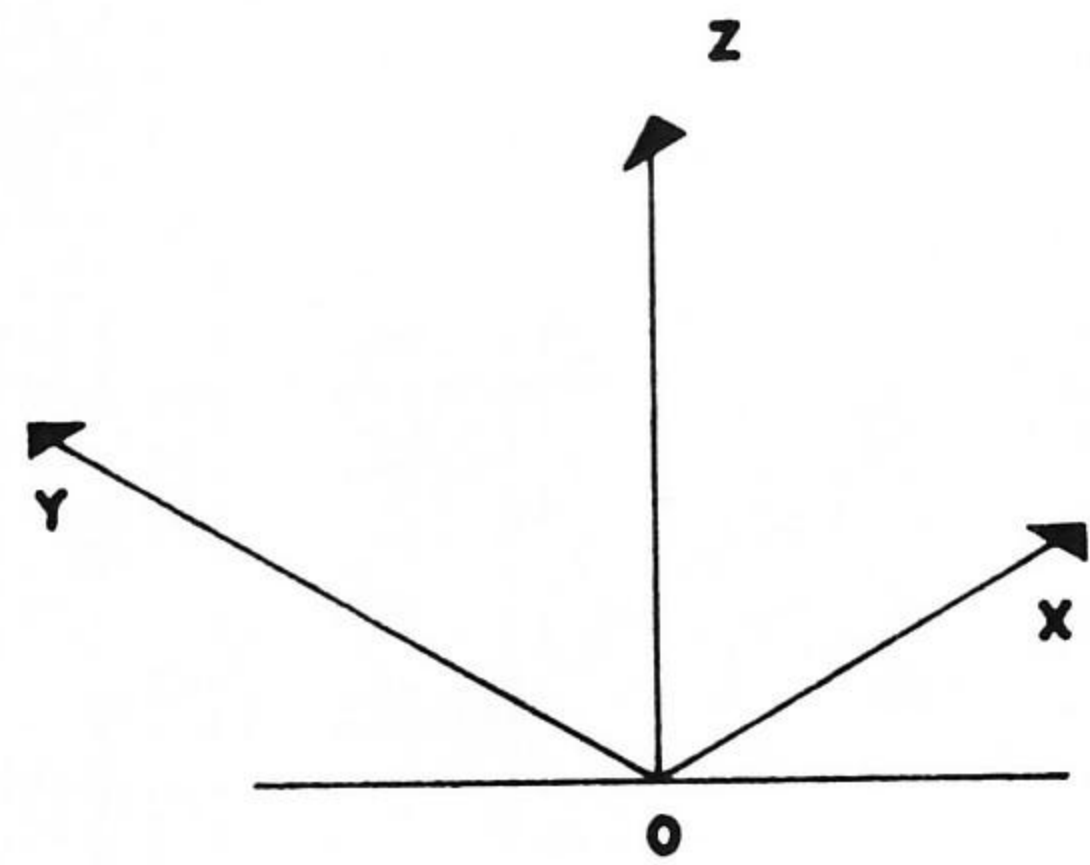
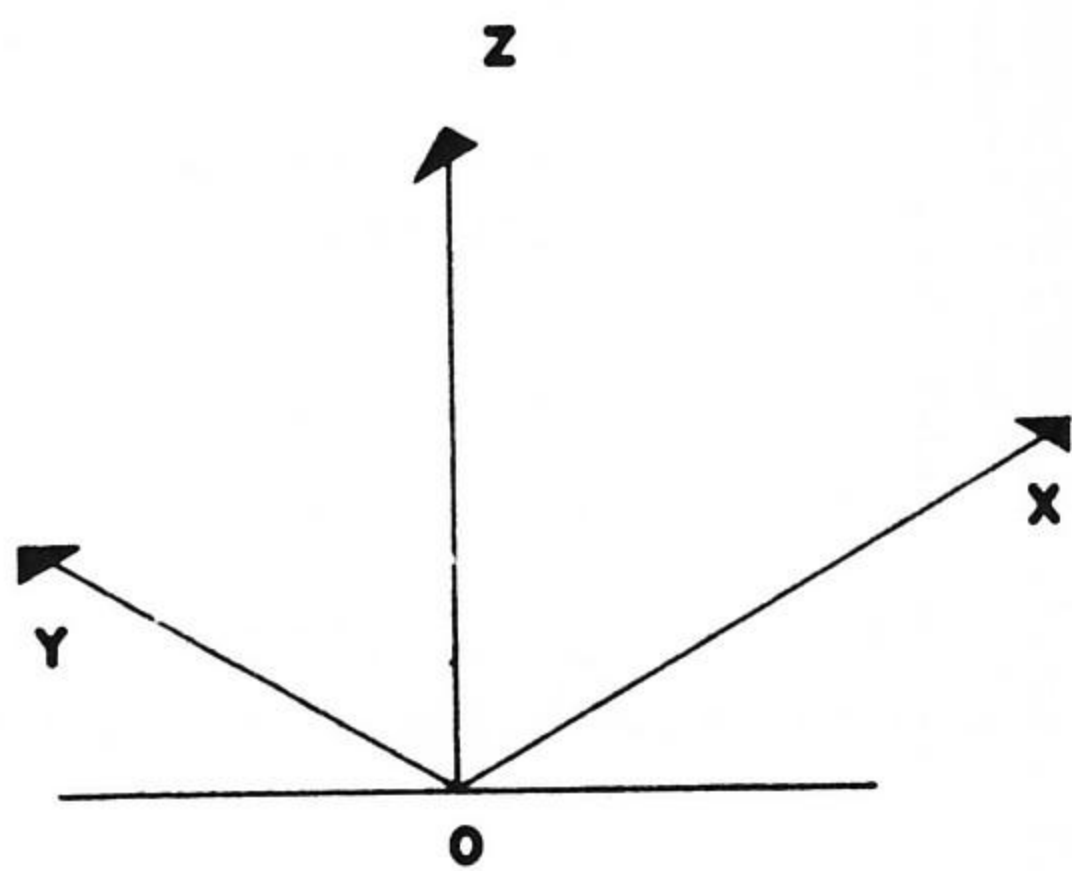

CONSIDERANDO LA ALTURA = 2 cm

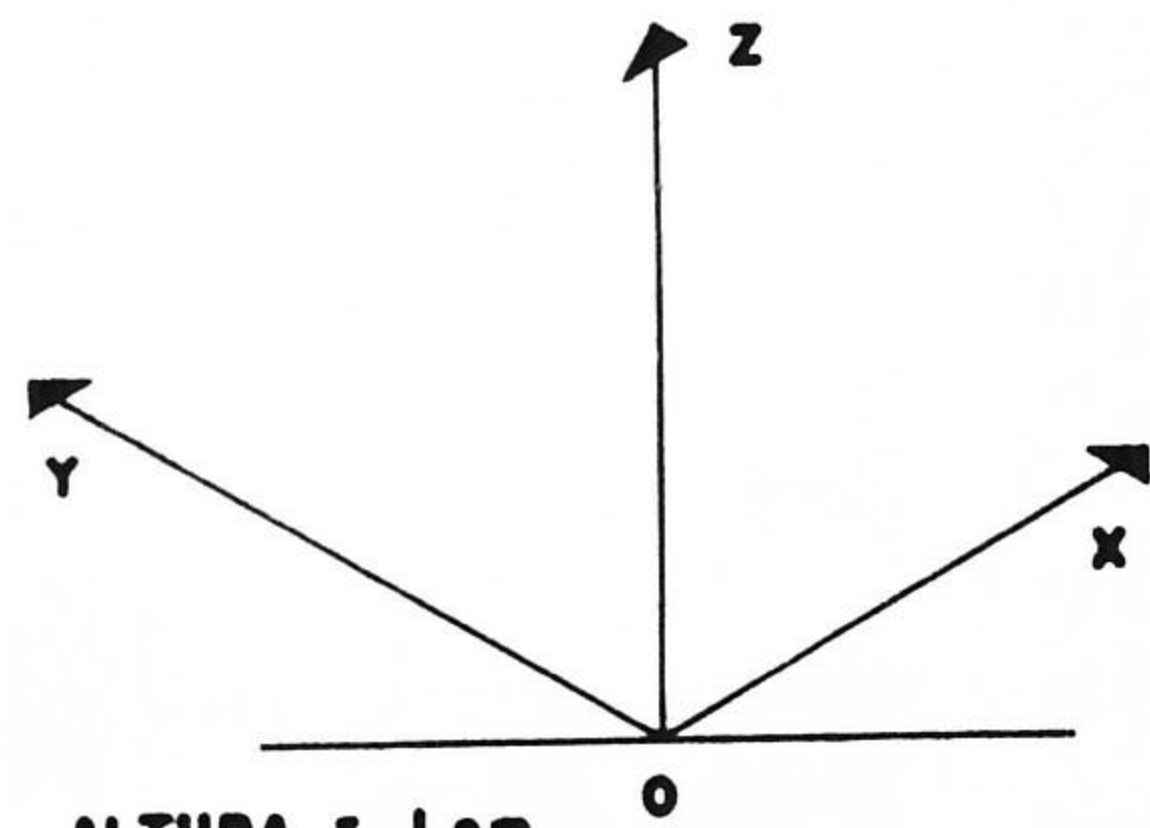
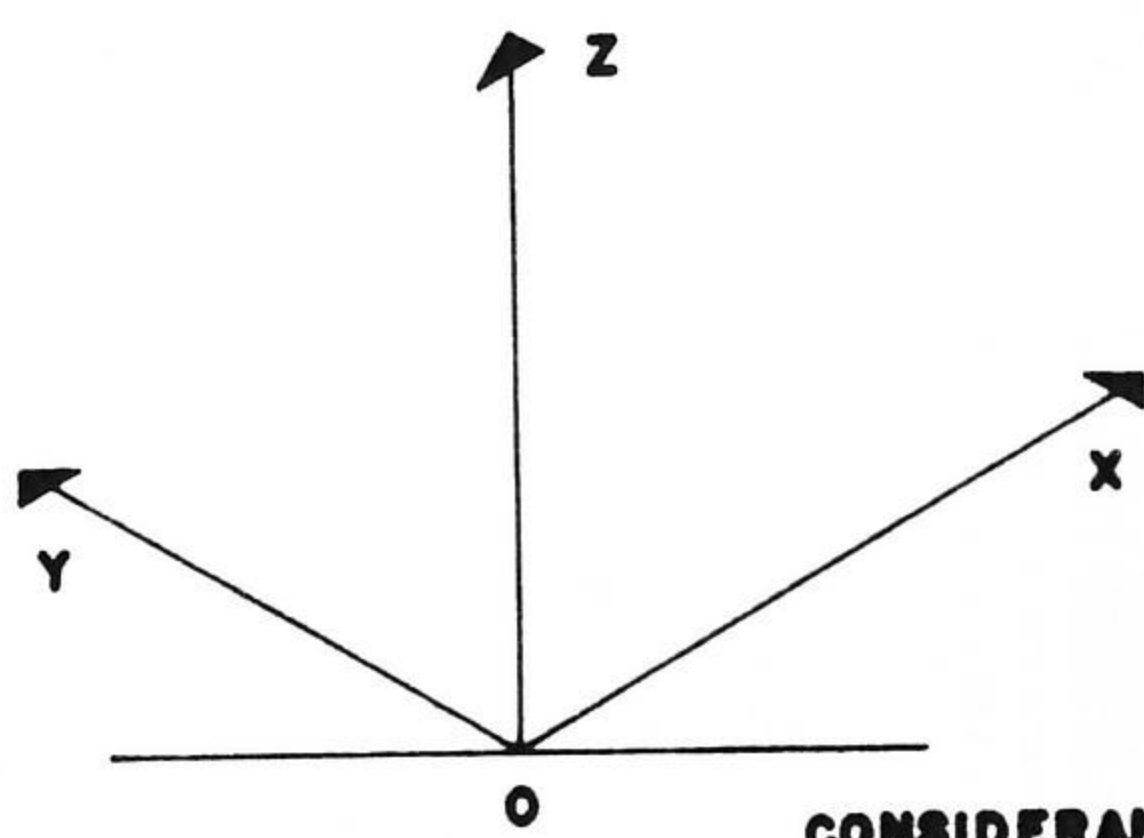

CONSIDERANDO LA ALTURA = 1 cm

DPTO. DISEÑO BASICO

**ISPJAE
FACULTAD DE ARQUITECTURA**

ASIGNATURA	TEMA		
DOC.	ALUM.	No.	GPO.
FECHA			EVAL.



1.4.2.b AXONOMETRIA.- CONSTRUIR UN CUBO DE 20mm DE ARISTA.

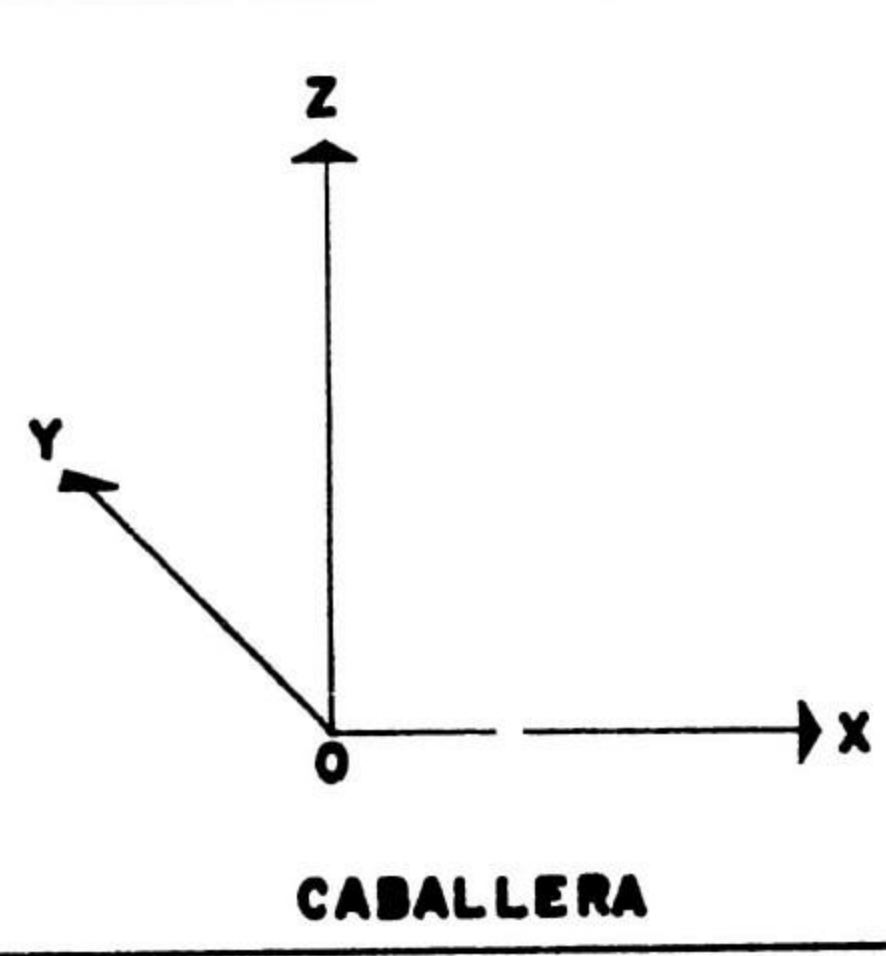
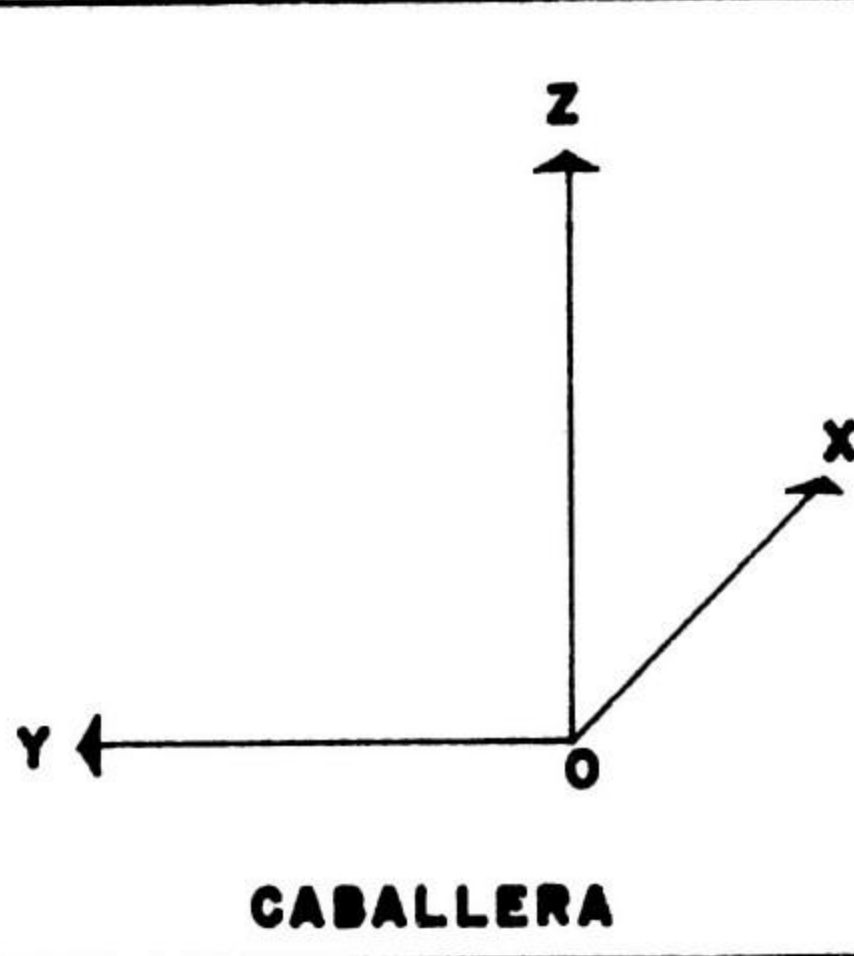
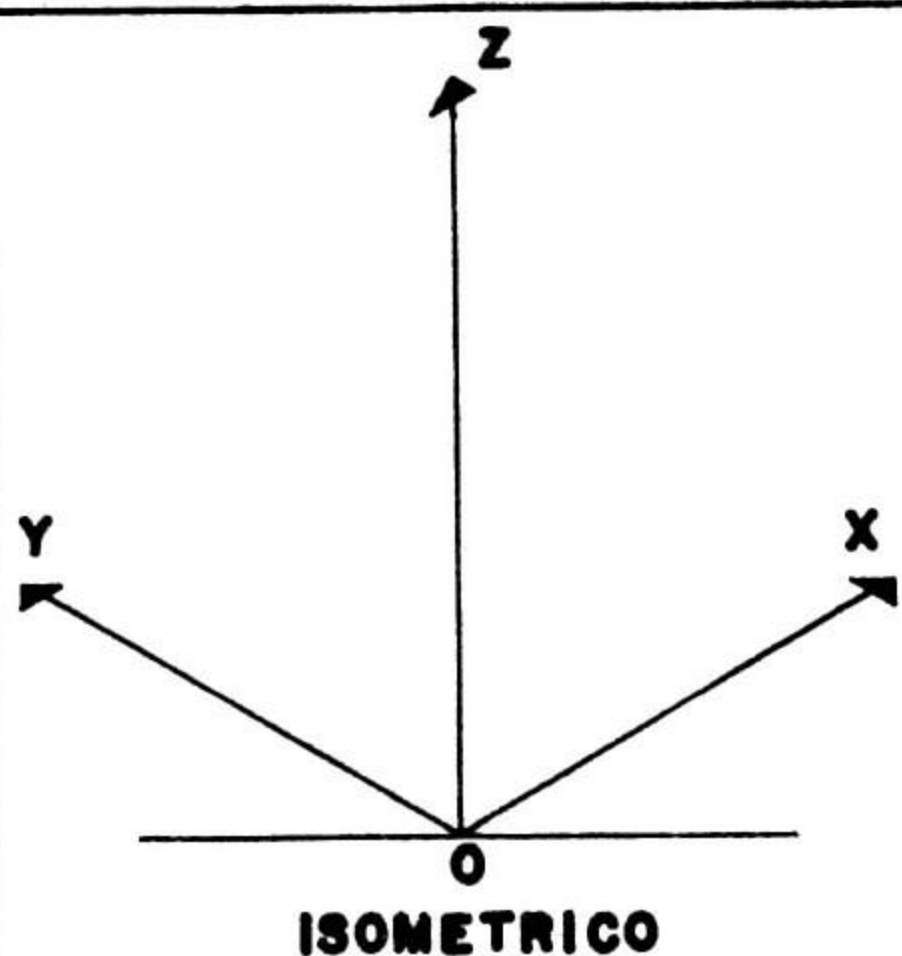

**AXONOMETRIA.- CONSTRUIR PLANOS DE PROYECCION DEL SISTEMA DIEDRICO.
 DATOS: SEMIPLANOS VERTICALES LIMITADOS A 40mm DE LARGO X 25mm DE ALTURA.
 SEMIPLANOS HORIZONTALES LIMITADOS A 40mm DE LARGO X 25mm DE ANCHO.
 (IDENTIFICAR LOS CUADRANTES)**

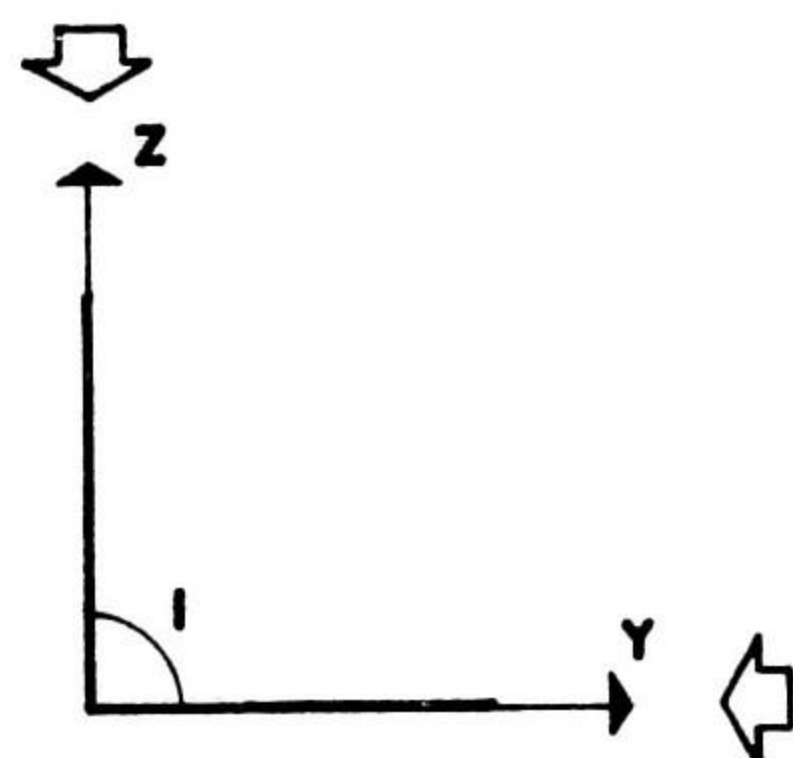
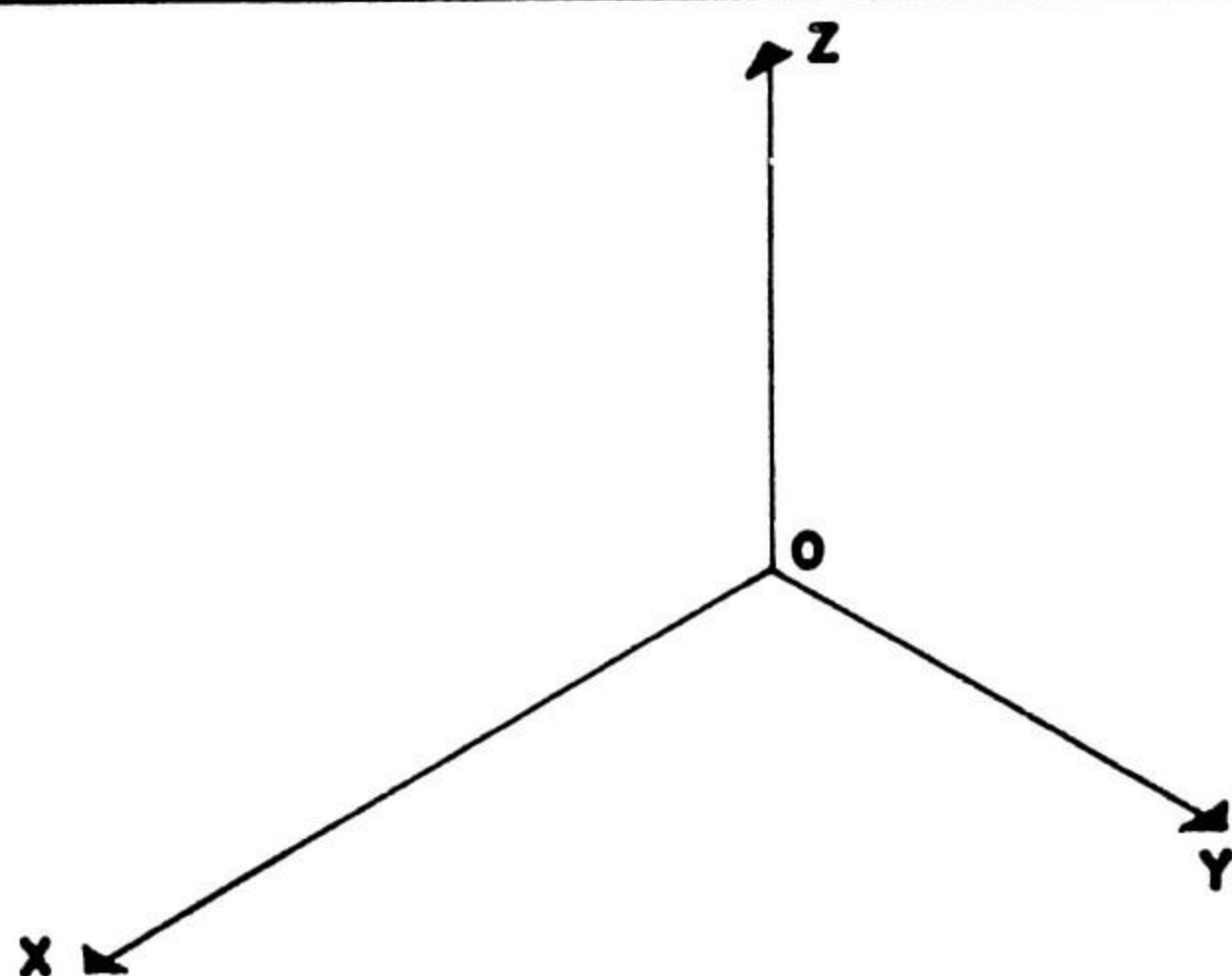

**VISTA LATERAL DEL SISTEMA PV-PH
 (PLANOS DE PROYECCION (DE CANTO).)**

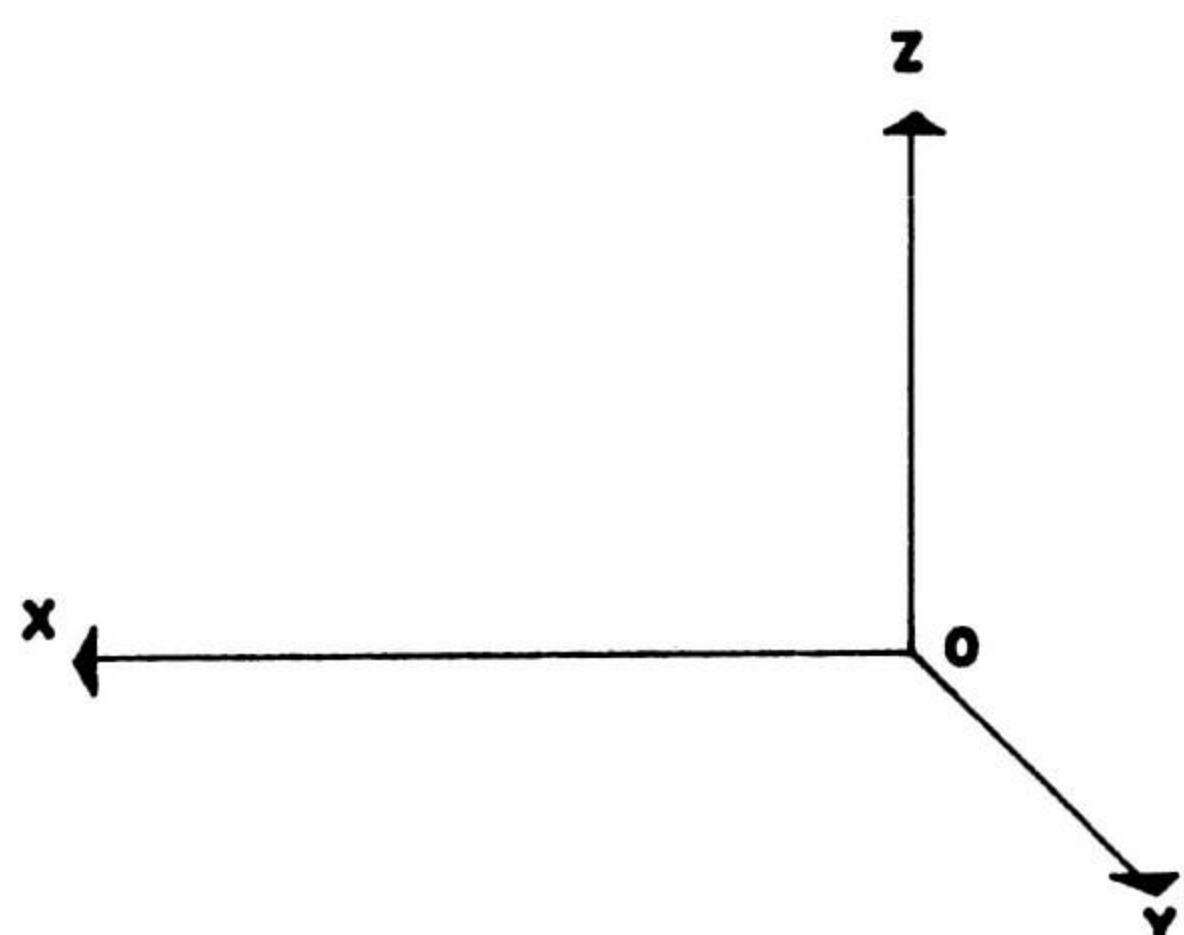
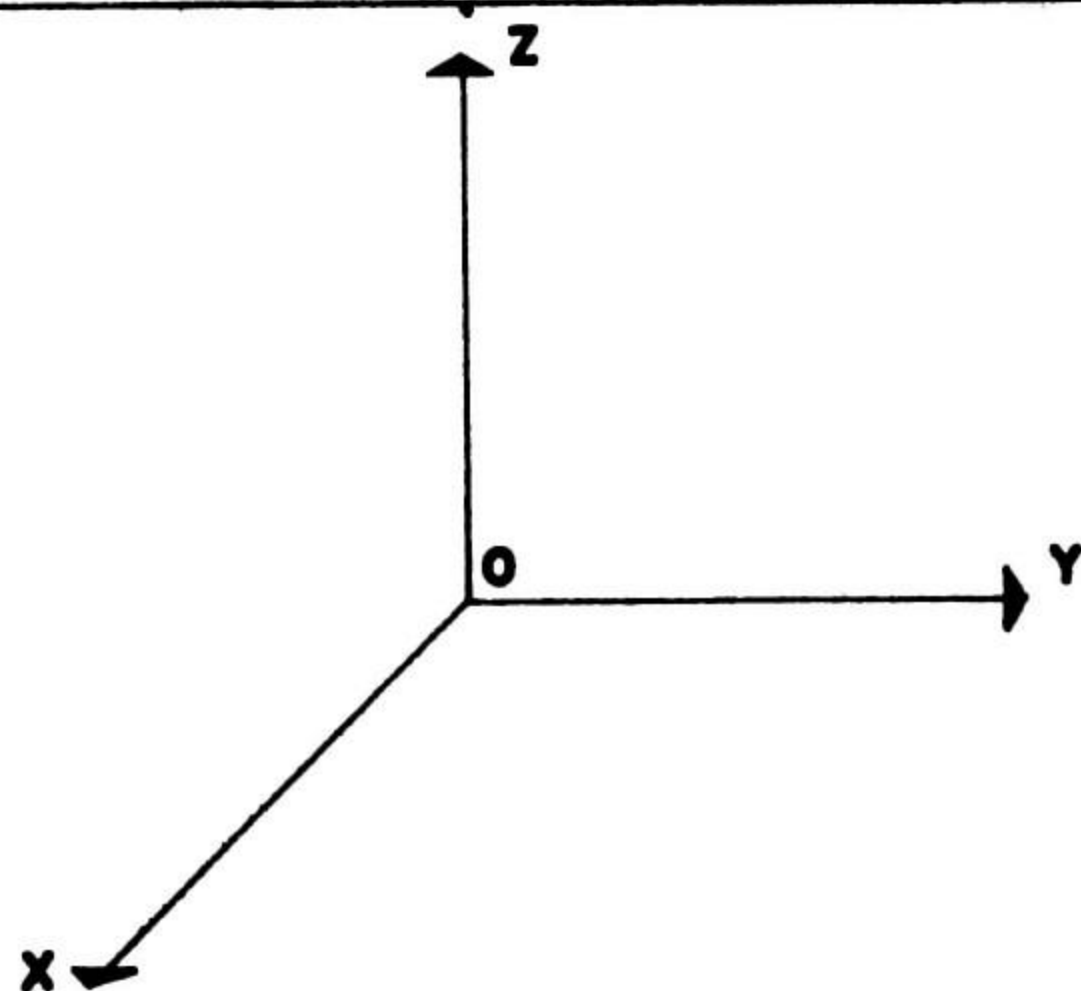

DPTO. DISEÑO BASICO

**ISPJAE
 FACULTAD DE ARQUITECTURA**

ASIGNATURA	TEMA		
DOC.	ALUM.	No.	GPO.
FECHA		EVAL.	



I. 4.5 DADA LA EQUIDISTANCIA DIBUJAR LA SECCION 1-1

40
35
30
25
20
15
10
5
0

SECCION 1-1

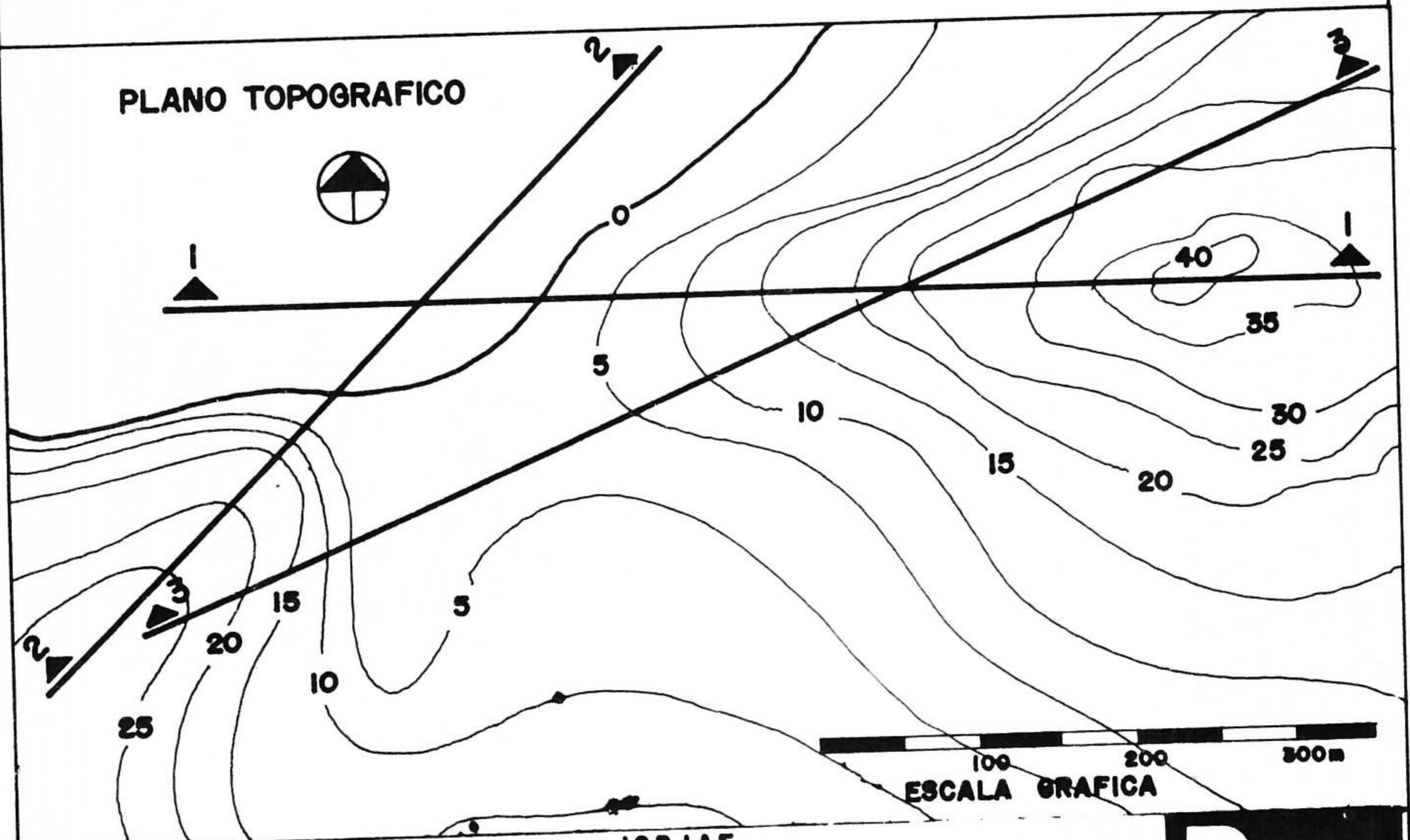

DPTO. DISEÑO BASICO

**ISPJAE
FACULTAD DE ARQUITECTURA**

ASIGNATURA	TEMA		
DOC.	ALUM.	No.	GPO.
FECHA			EVAL.

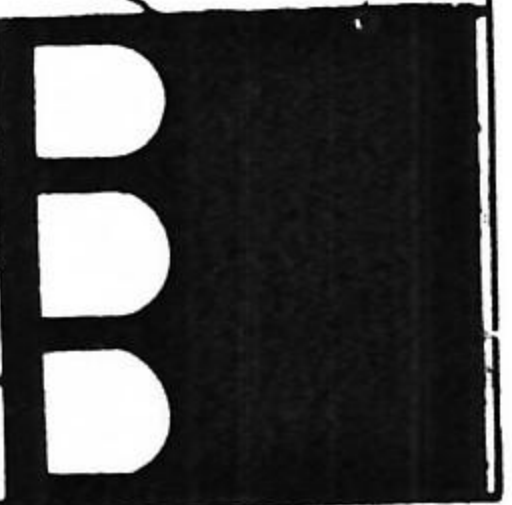

2.2.2.b INTRODUCCION AL SISTEMA TRIEDRICO

CONSTRUIR LAS PROYECCIONES VERTICAL Y HORIZONTAL:
 1) EN LA CABALLERA
 2) REFERIDAS A LA LINEA DE TIERRA DADA

A

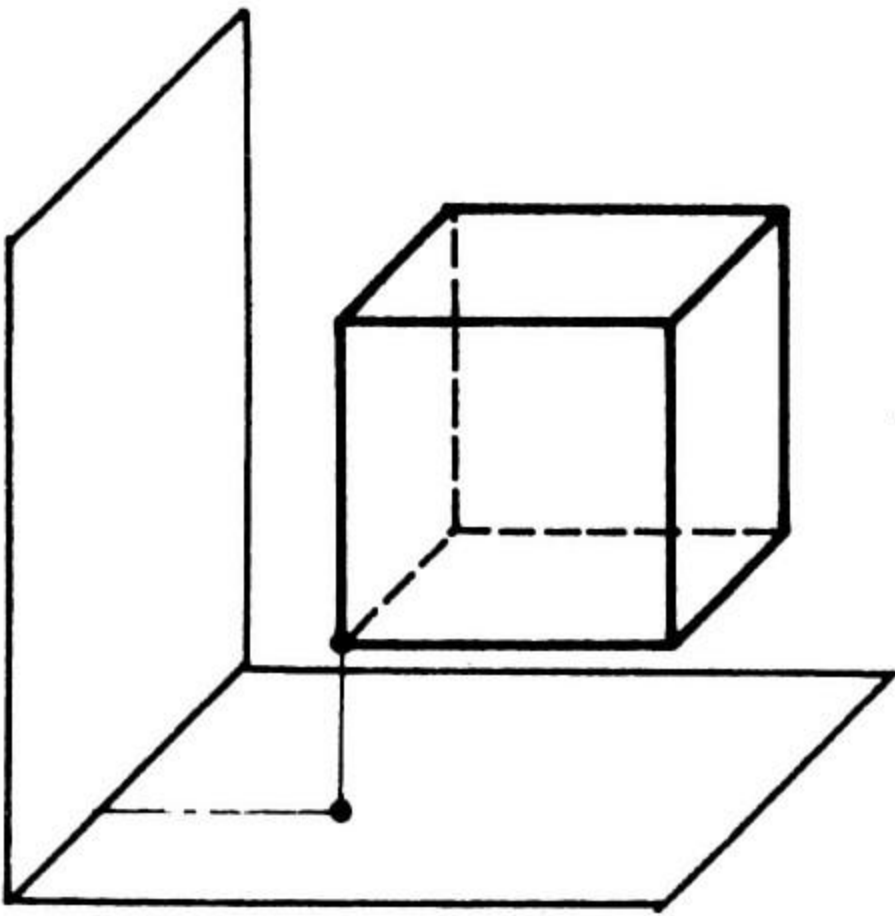

B

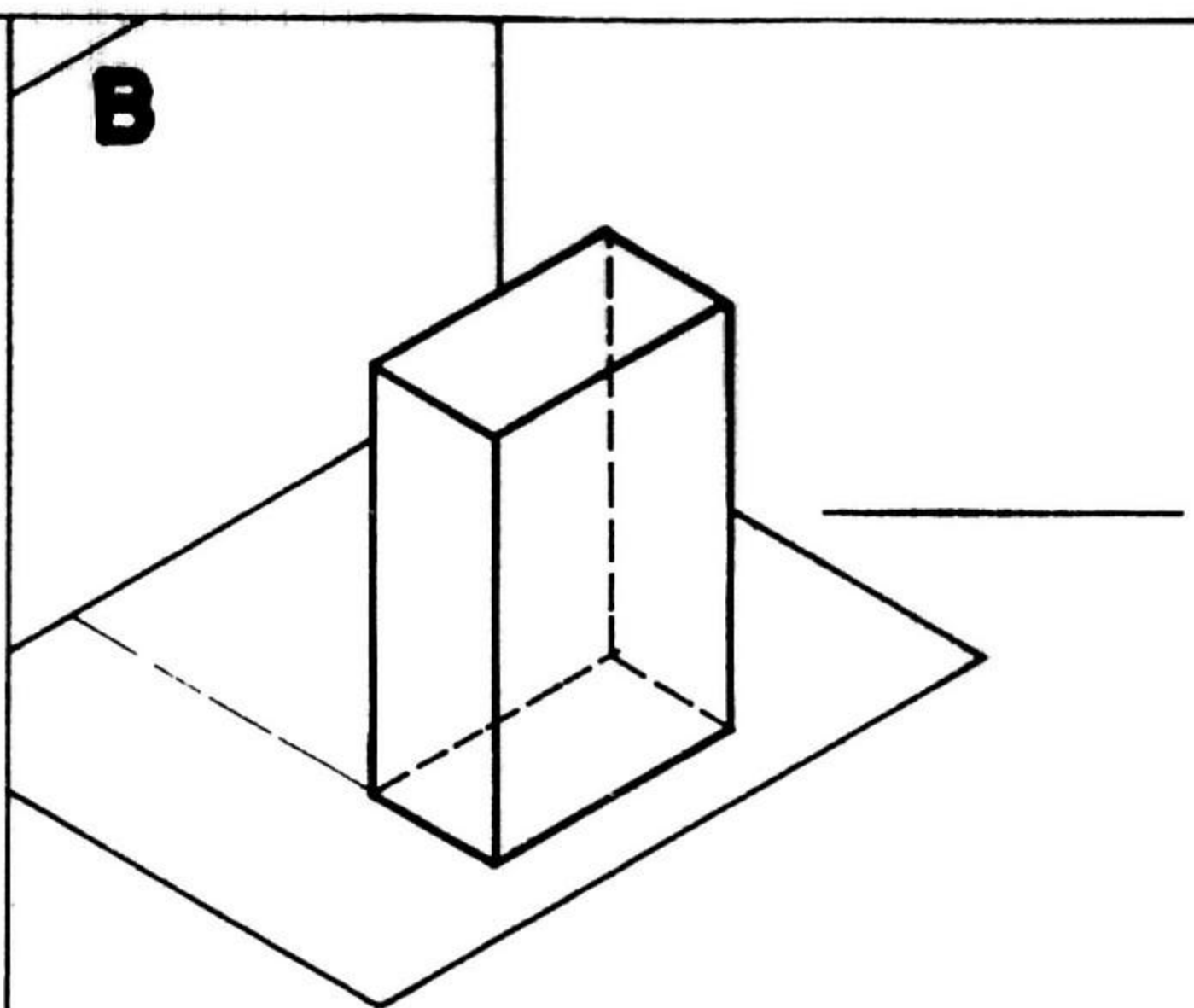

C

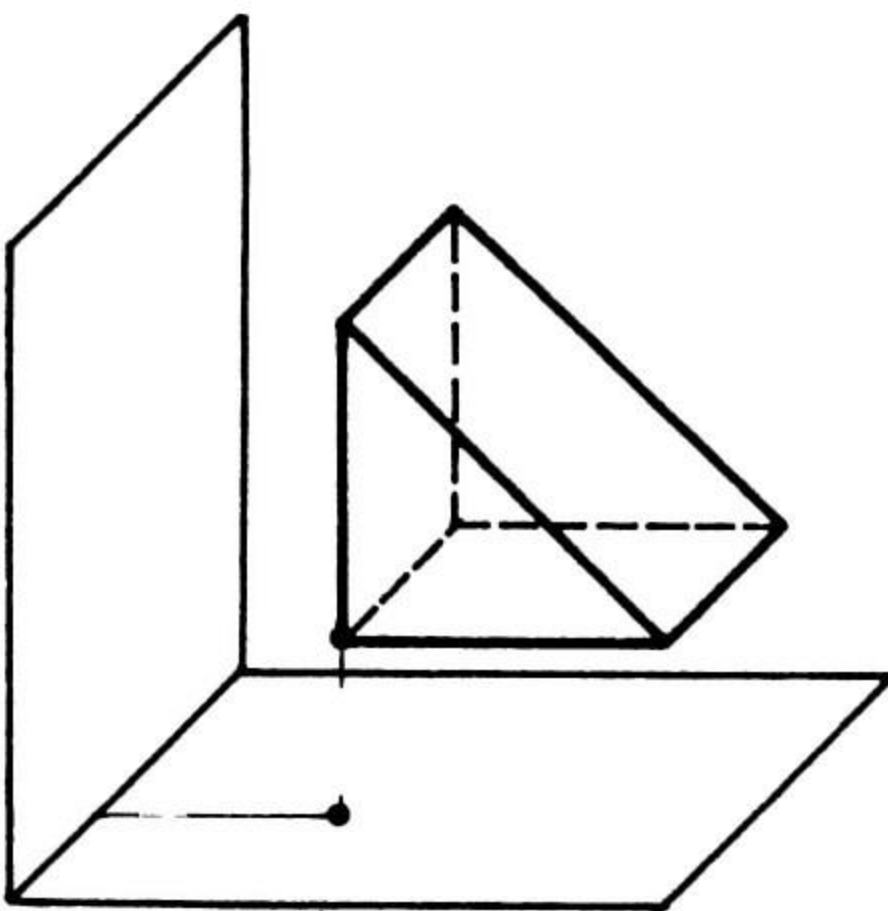

D

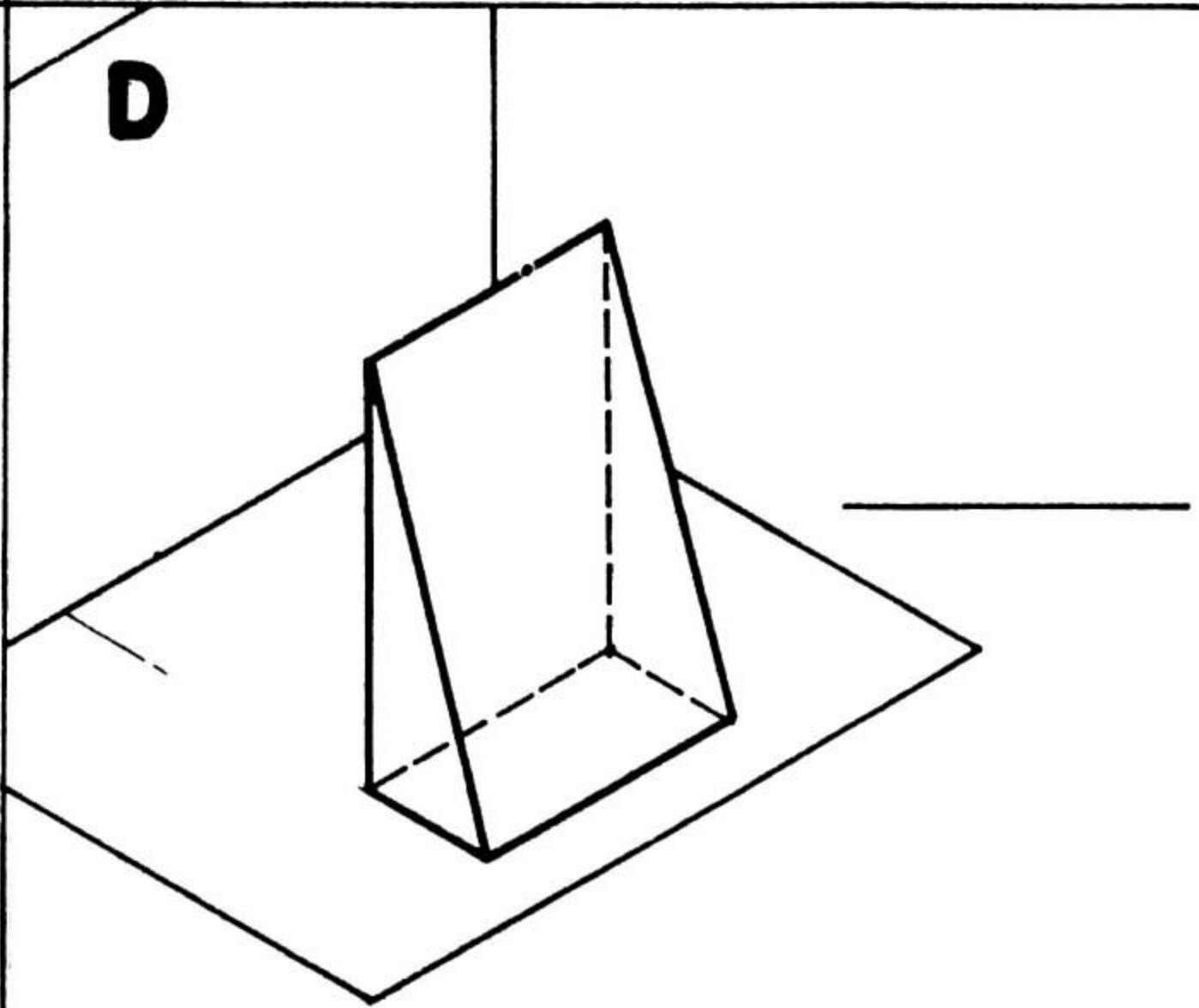

E

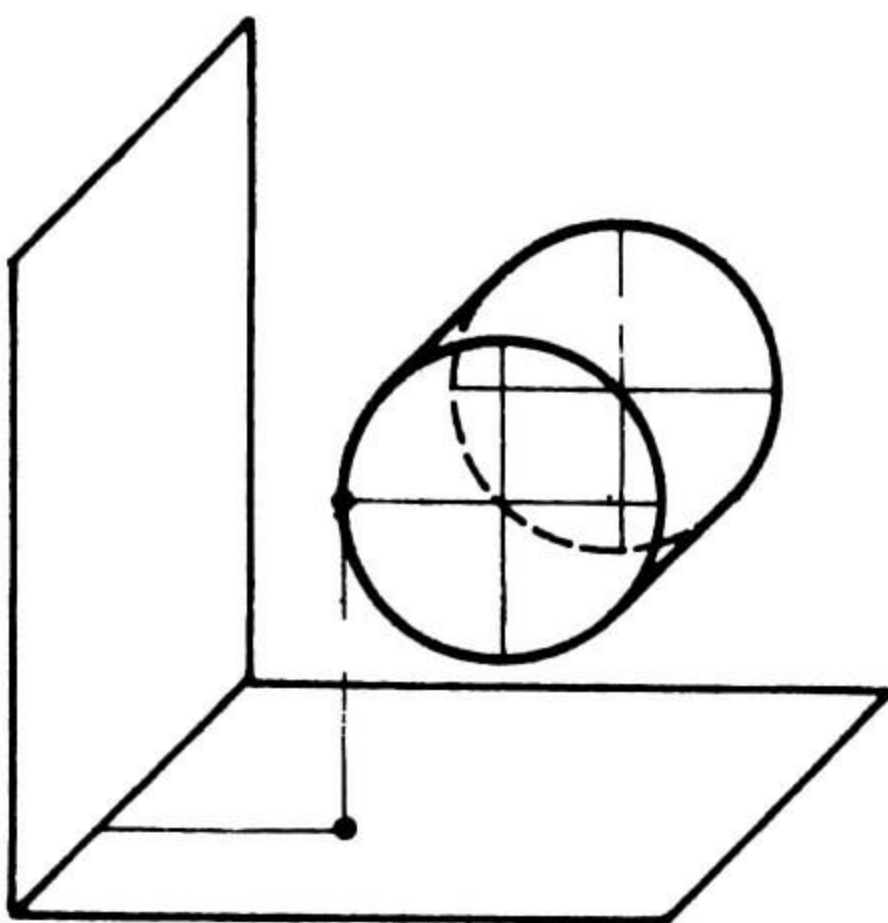

F

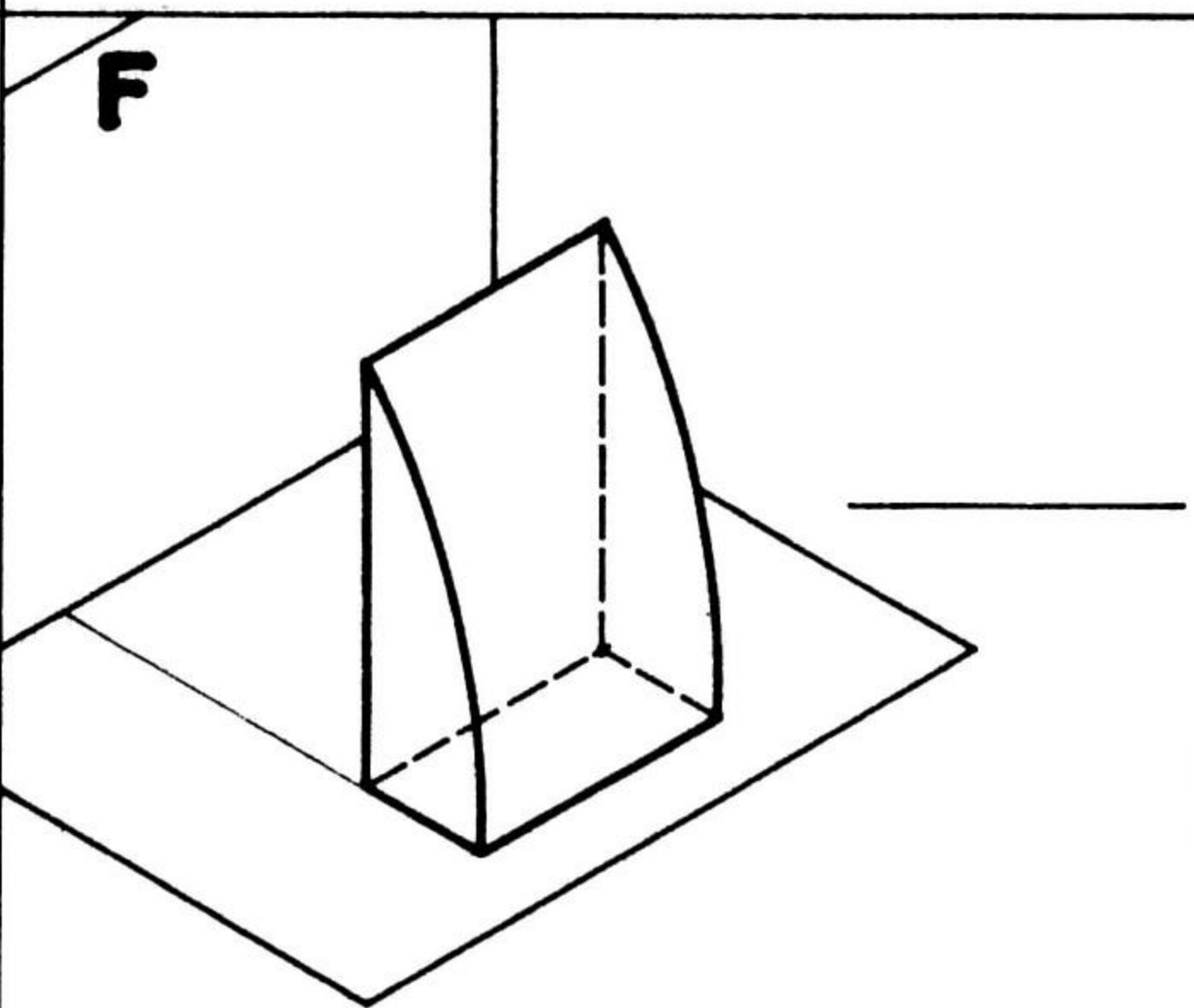

DPTO. DISEÑO BASICO

**ISPJAE
 FACULTAD DE ARQUITECTURA**

ASIGNATURA	TEMA		
DOC.	ALUM.	No.	GPO.
FECHA			EVAL.



2.3. a REPRESENTAR EN PROYECCIONES ORTOGONALES LOS PUNTOS DADOS EN EL ISOMETRICO E INDICAR EN QUE CUADRANTES ESTAN SITUADOS.

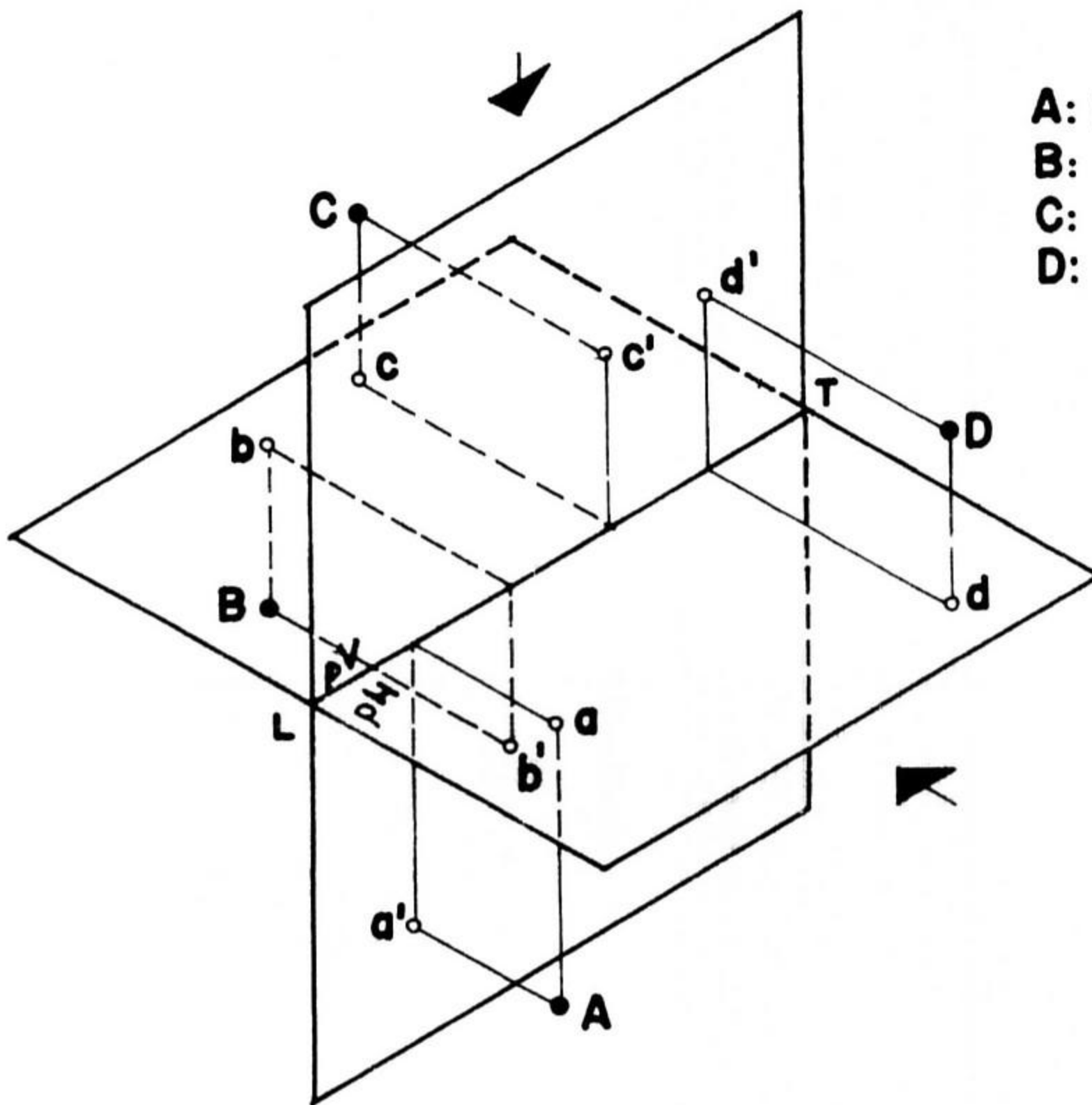

A: PUNTO EN _____ CUADRANTE
 B: " " _____ "
 C: " " _____ "
 D: " " _____ "



SITUAR LOS PUNTOS E, F, G Y Q Y SUS PROYECCIONES RESPECTIVAS EN EL ISOMETRICO E INDICAR EN QUE SEMIPLANO ESTAN SITUADOS.

E: PUNTO EN SEMIPLANO _____
 F: " " " _____
 G: " " " _____
 Q: " " " _____

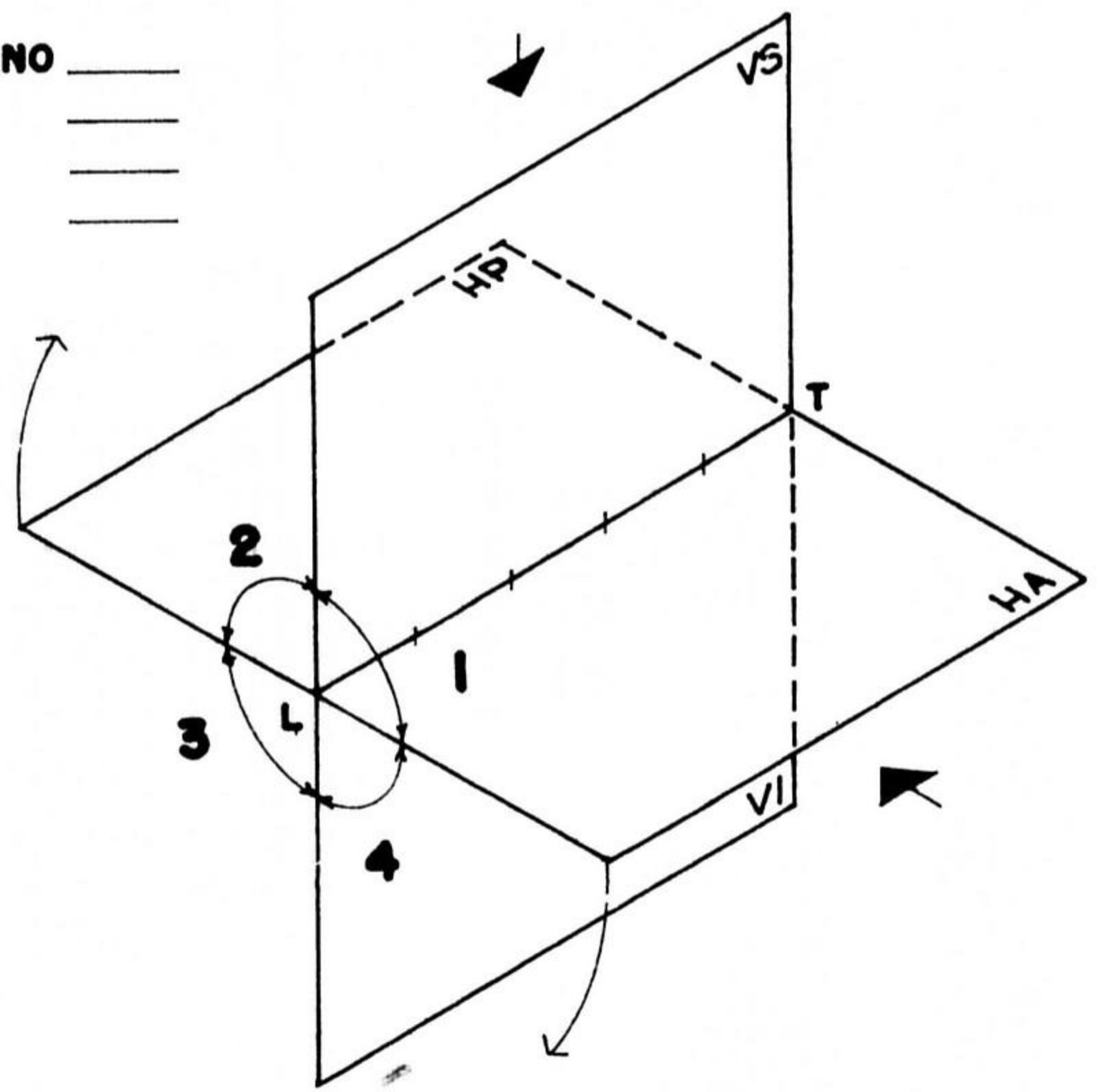
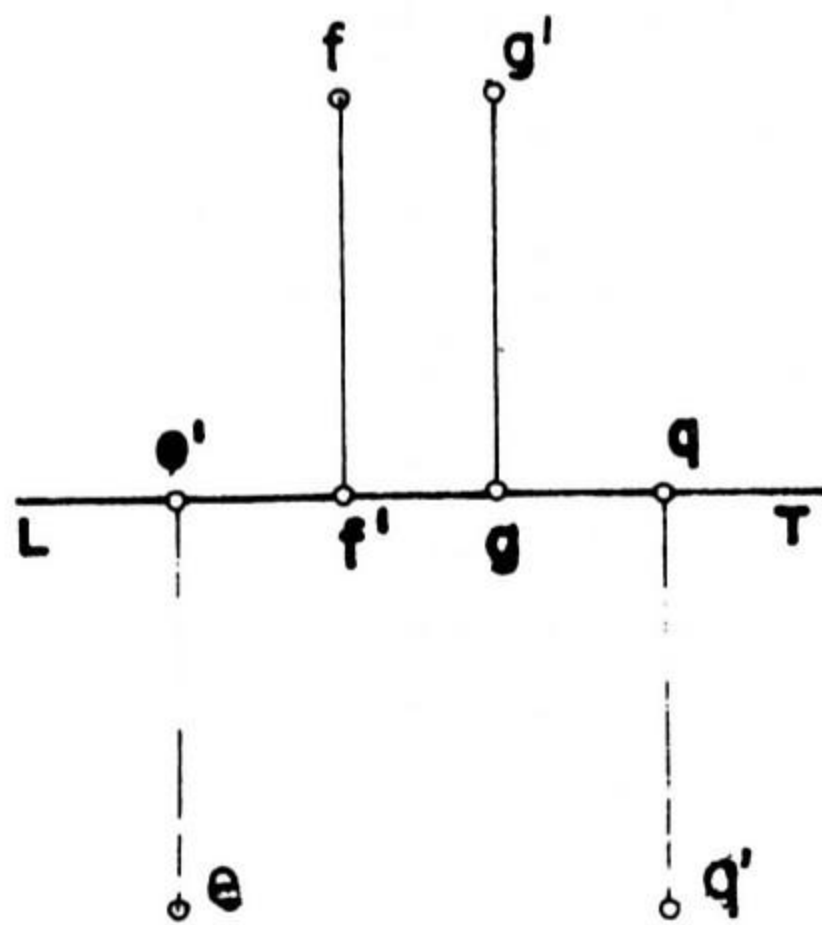

DPTO. DISEÑO BASICO

**ISPJAE
 FACULTAD DE ARQUITECTURA**

ASIGNATURA	TEMA		
DOC.	ALUM.	No.	EPO.
FECHA		EVAL.	

2.3. b INTERPRETAR LAS PROYECCIONES ORTOGONALES DE LOS PUNTOS DADOS. INDICAR SUS POSICIONES RESPECTIVAS EN LOS LUGARES CORRESPONDIENTES DEL CUADRO SEGUN LA NOTACION.

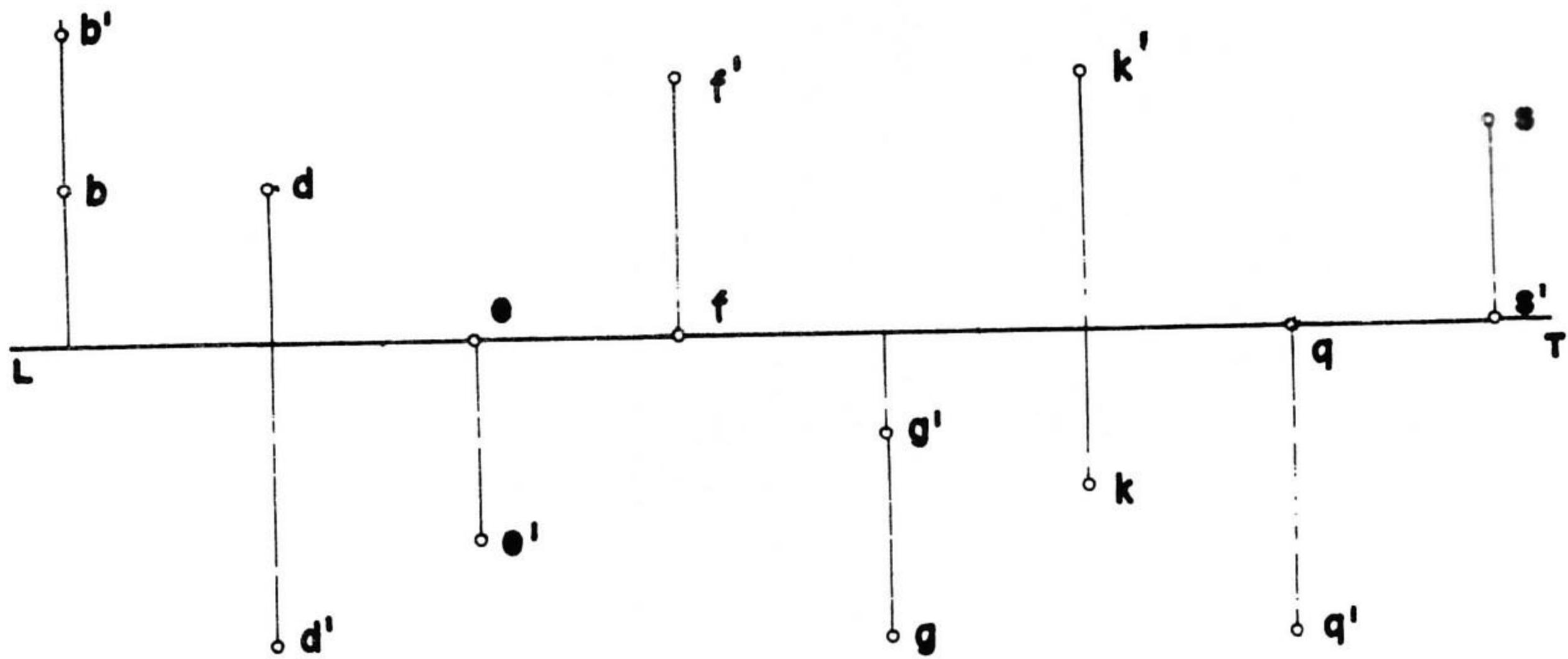

NOTACION :

$c > a$ = cota > alejamiento.
 $c < a$ = cota < alejamiento.

VS = vertical superior.
 VI = vertical inferior.
 HA = horizontal anterior.
 HP = horizontal posterior.

INTERPRETACION DE LAS PROYECCIONES.

PUNTO	SEPARADO DE LOS PLANOS DE PROYECCION.			CONTENIDO EN SEMIPLANO.			
	cuadrante	$c > a$	$c < a$	VS	VI	HA	HP
B							
D							
E							
F							
S							
K							
Q							
S							

DPTO. DISEÑO BASICO		ISPJAE FACULTAD DE ARQUITECTURA		D D D
ASIGNATURA	TEMA			
DOC.	ALUM.	No.	SPO.	
FECHA			EVAL.	

2.4. a DADAS LAS RECTAS AB, BC, CD, DE Y EF POR SUS PROYECCIONES ORTOGONALES : DIBUJARLAS EN EL ISOMETRICO.

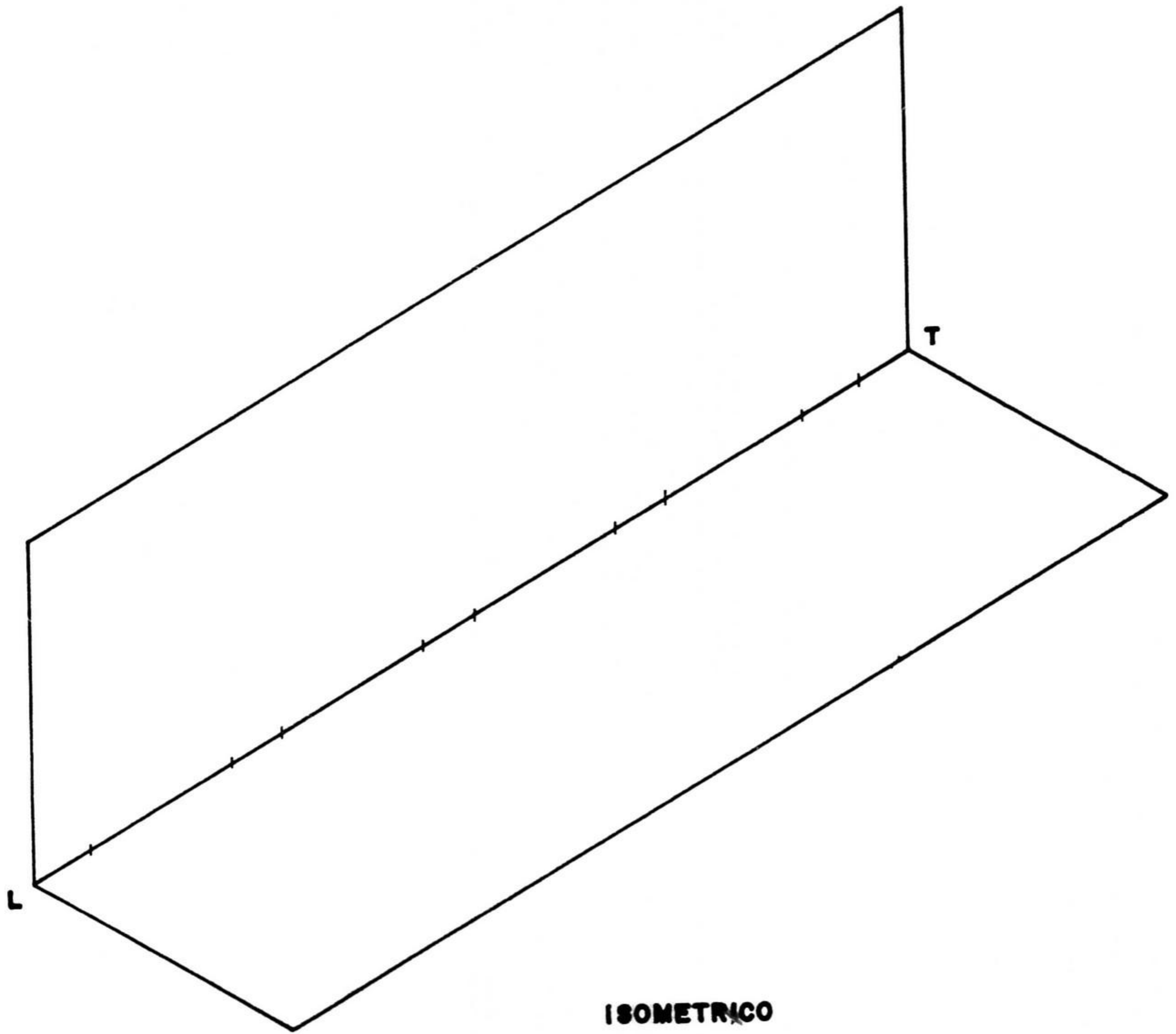
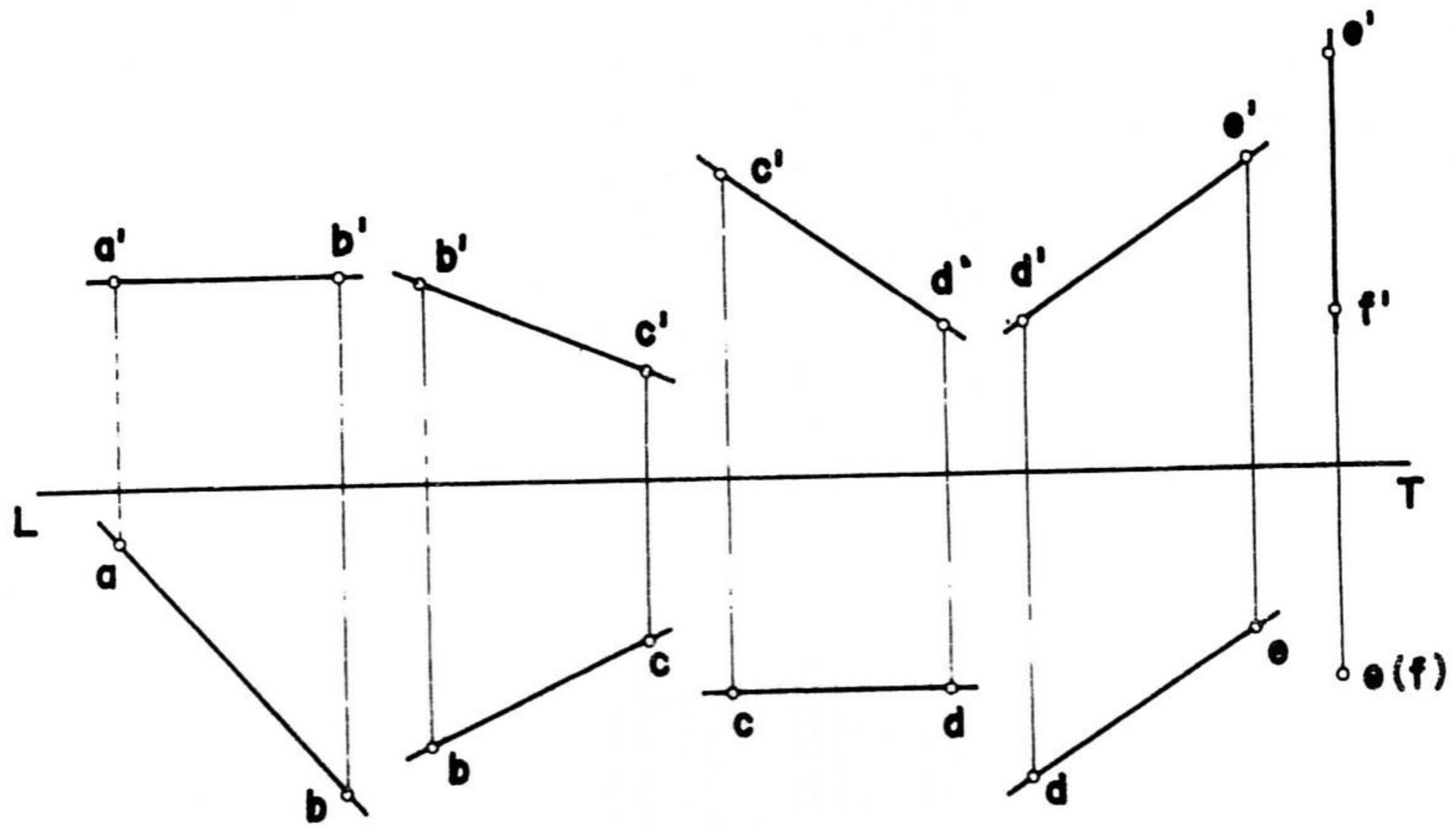

DPTO. DISEÑO BASICO		ISPJAE	
		FACULTAD DE ARQUITECTURA	
SIGNATURA	TEMA		
DOC.	ALUM.	No.	GPO.
FECHA			EVAL.

2.4.b DADAS LAS RECTAS AB, BC, CD Y DE POR LAS PROYECCIONES ORTOGONALES DE DOS DE SUS PUNTOS; REPRESENTARLAS EN EL ISOMETRICO.

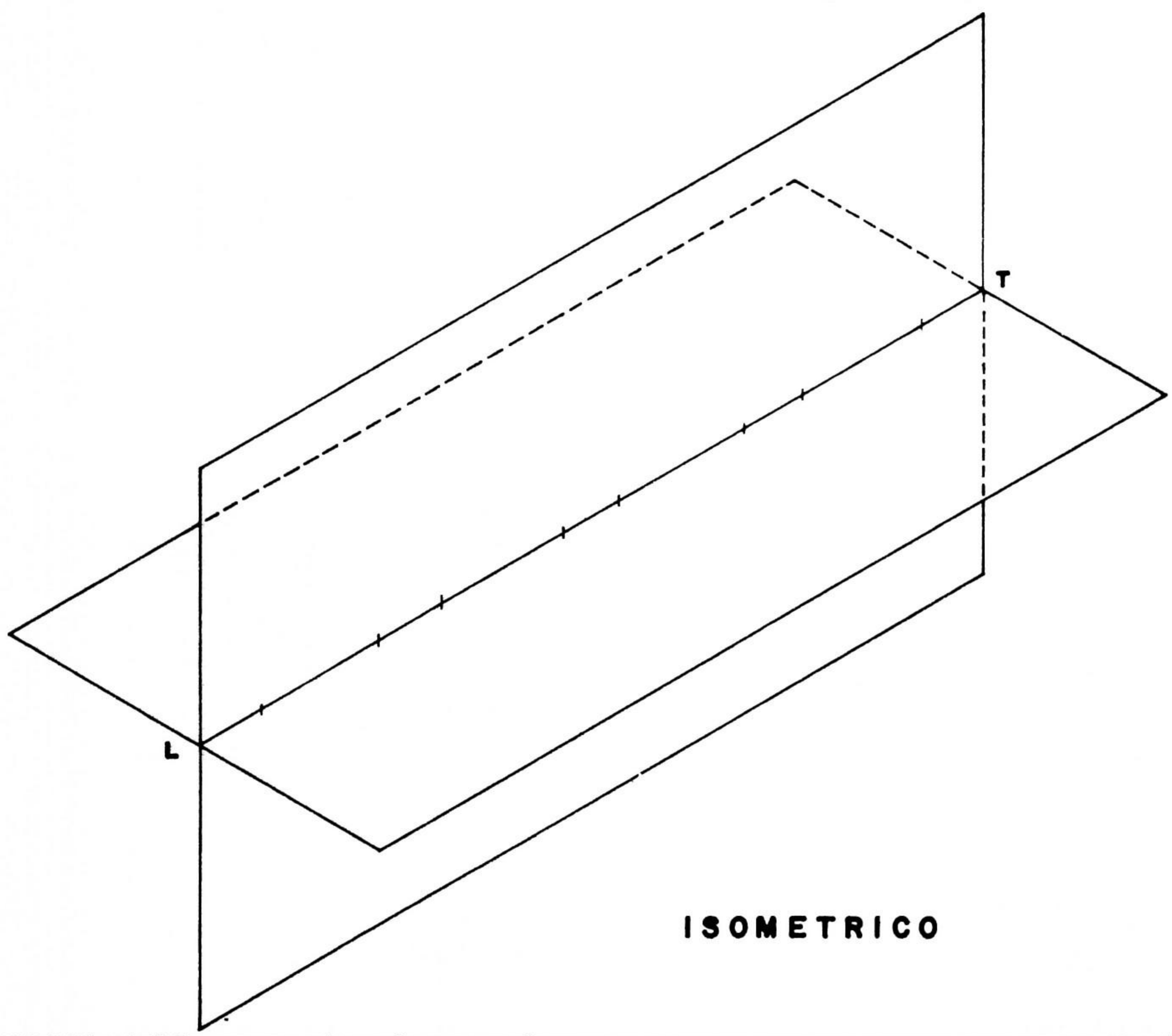
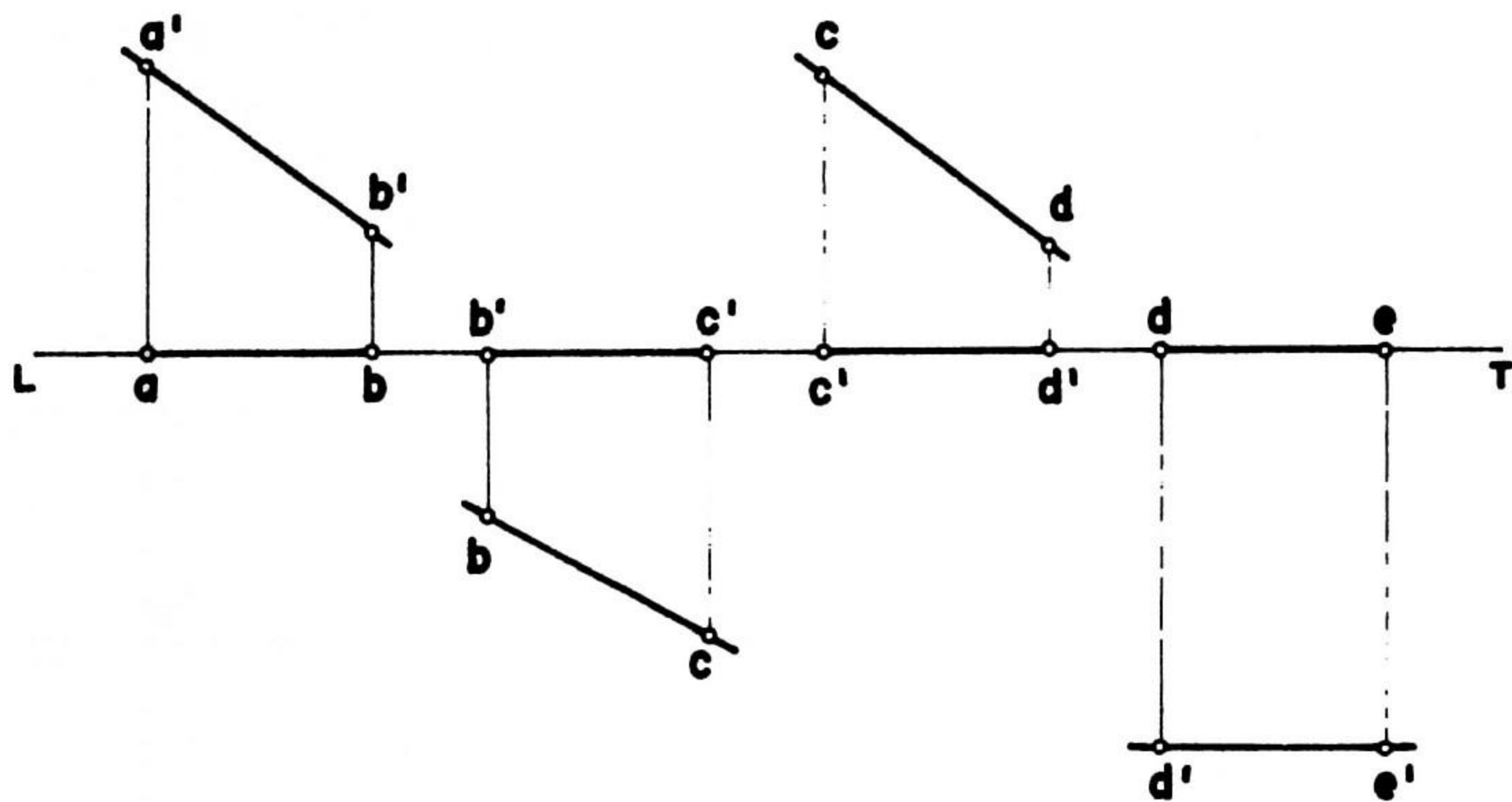

DPTO. DISEÑO BASICO		ISPJAE FACULTAD DE ARQUITECTURA		D D D
ASIGNATURA	TEMA			
DOC.	ALUM.	No.	GPO.	
FECHA			EVAL.	

2.4.6 CONSTRUIR LAS TRAZAS DE LAS RECTAS DADAS POR SUS PROYECCIONES. DETERMINAR LOS CUADRANTES POR LOS QUE PASAN LAS RECTAS. REPRESENTAR LOS EJERCICIOS EN DIBUJO ISOMETRICO.

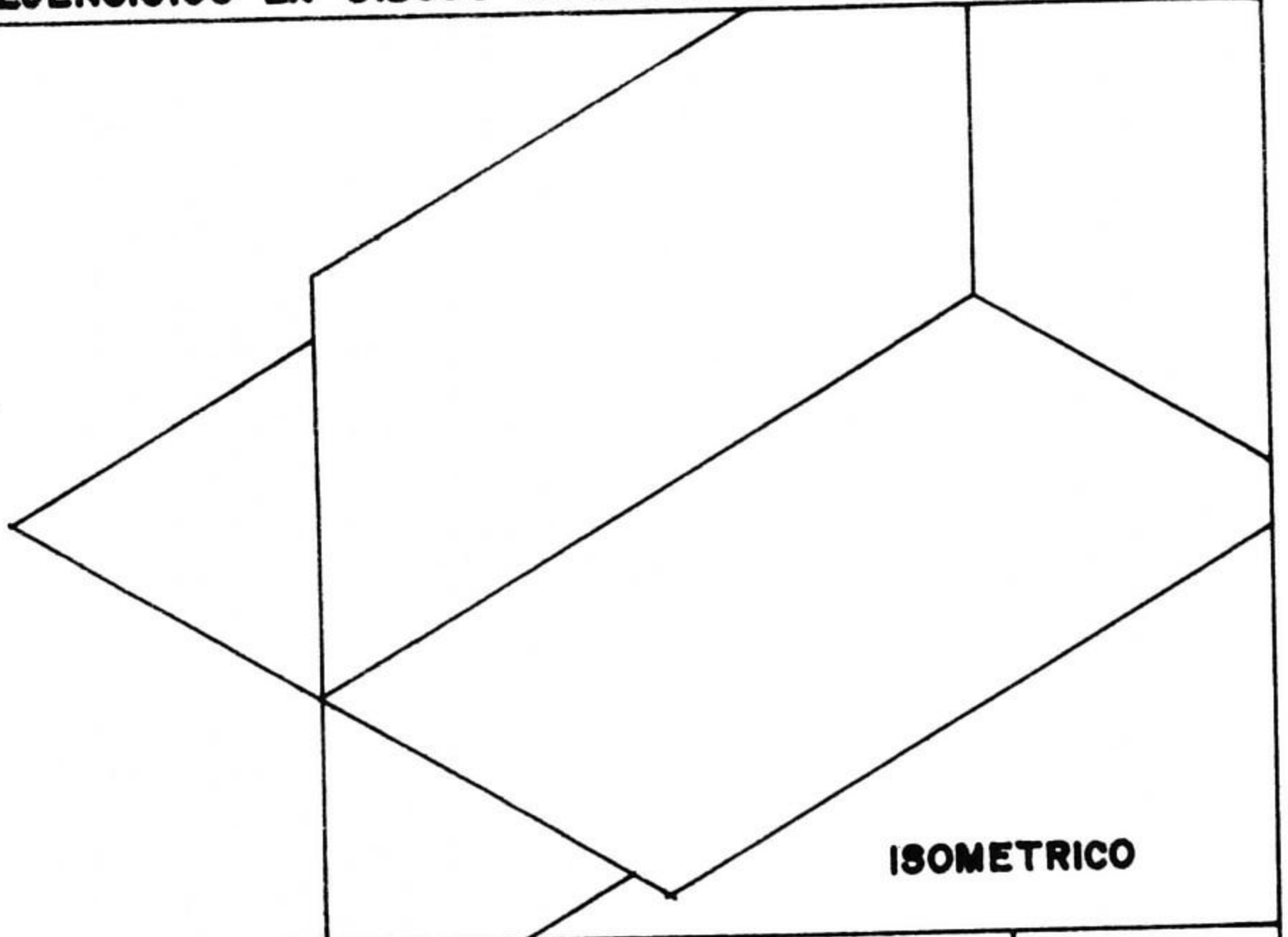
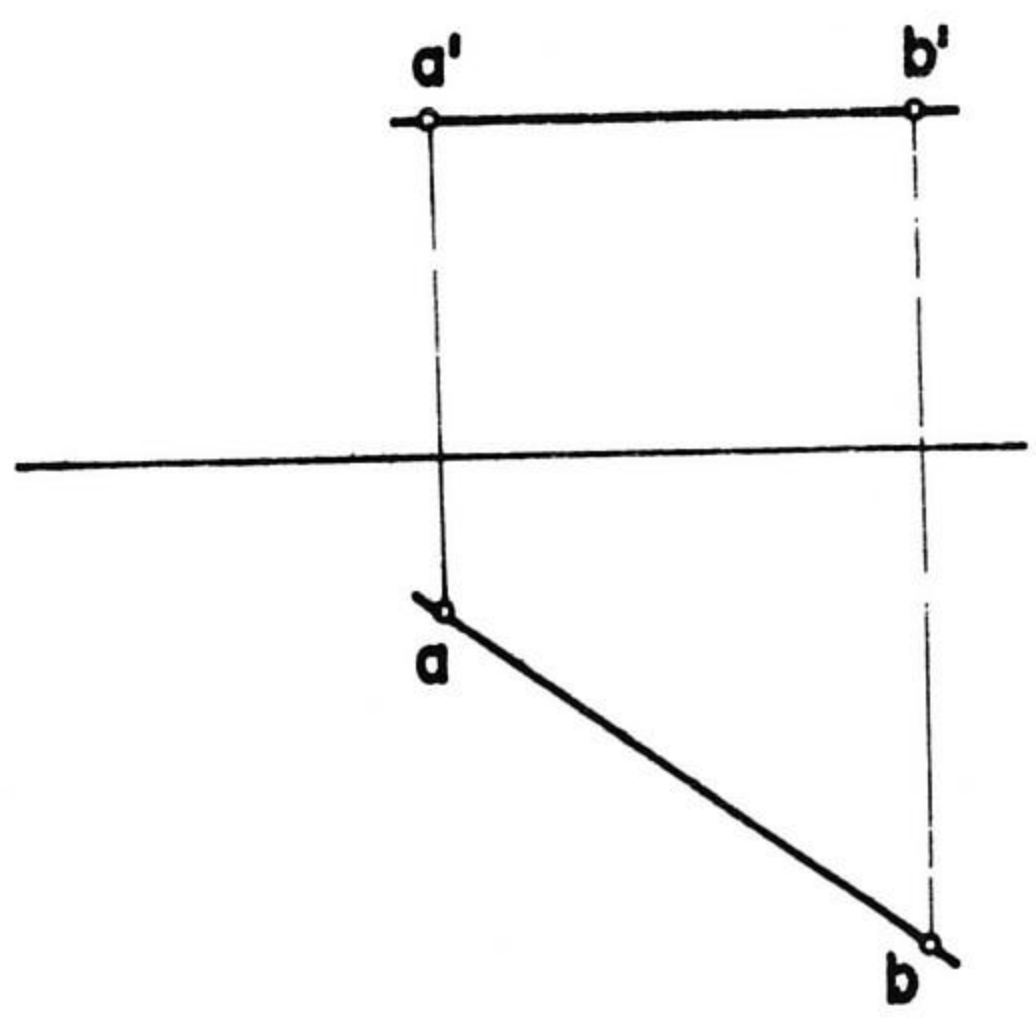

ISOMETRICO

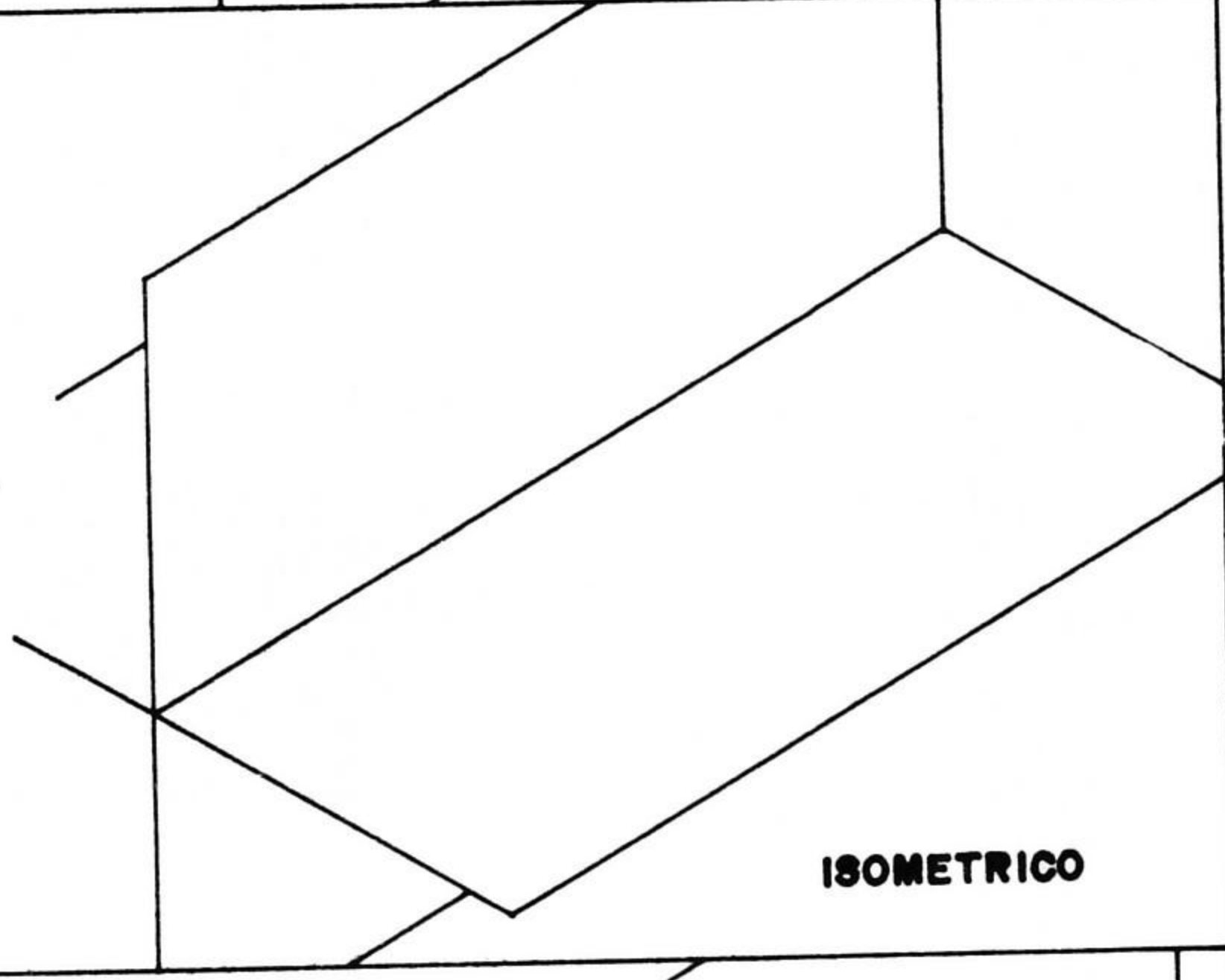
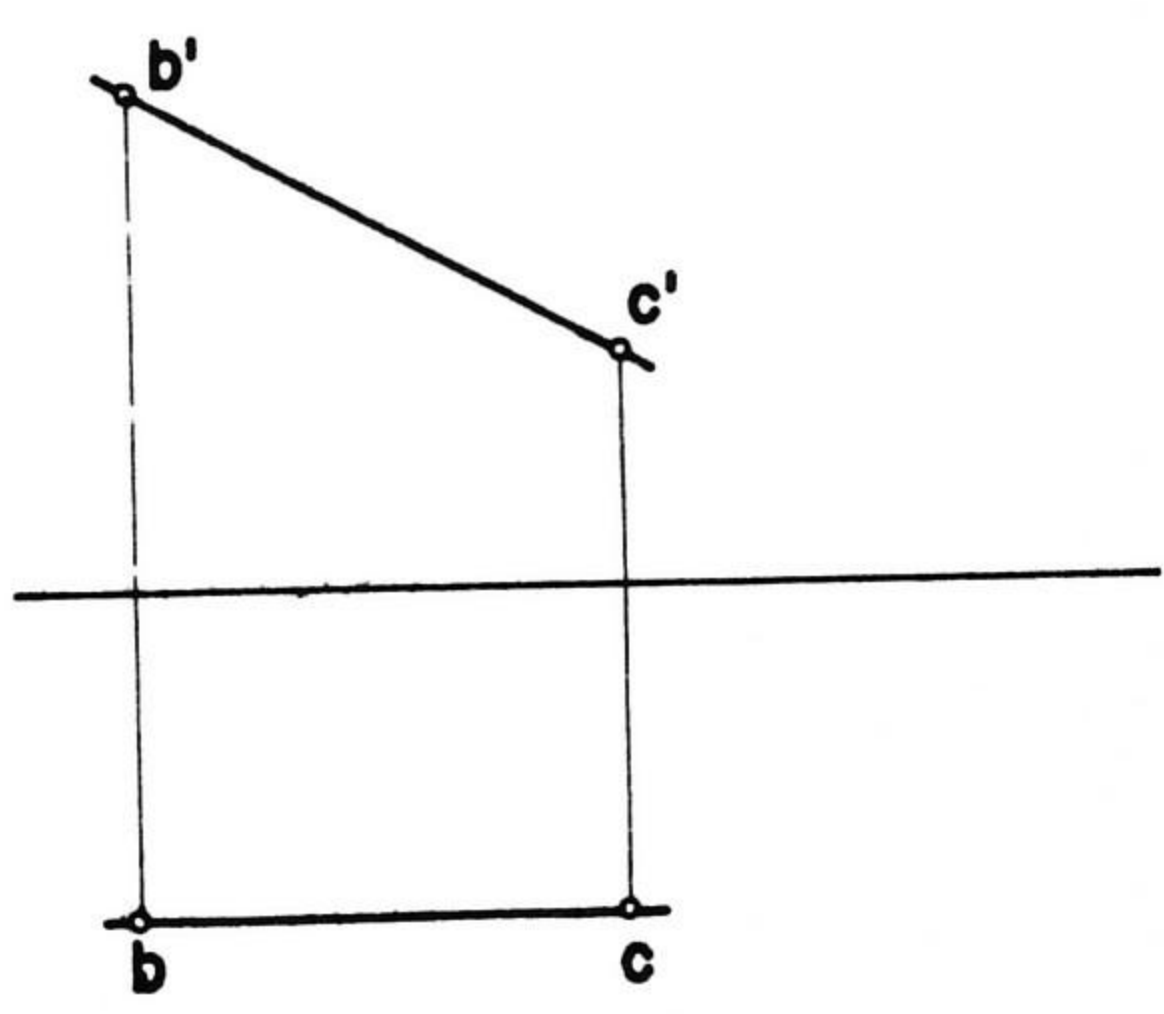

ISOMETRICO

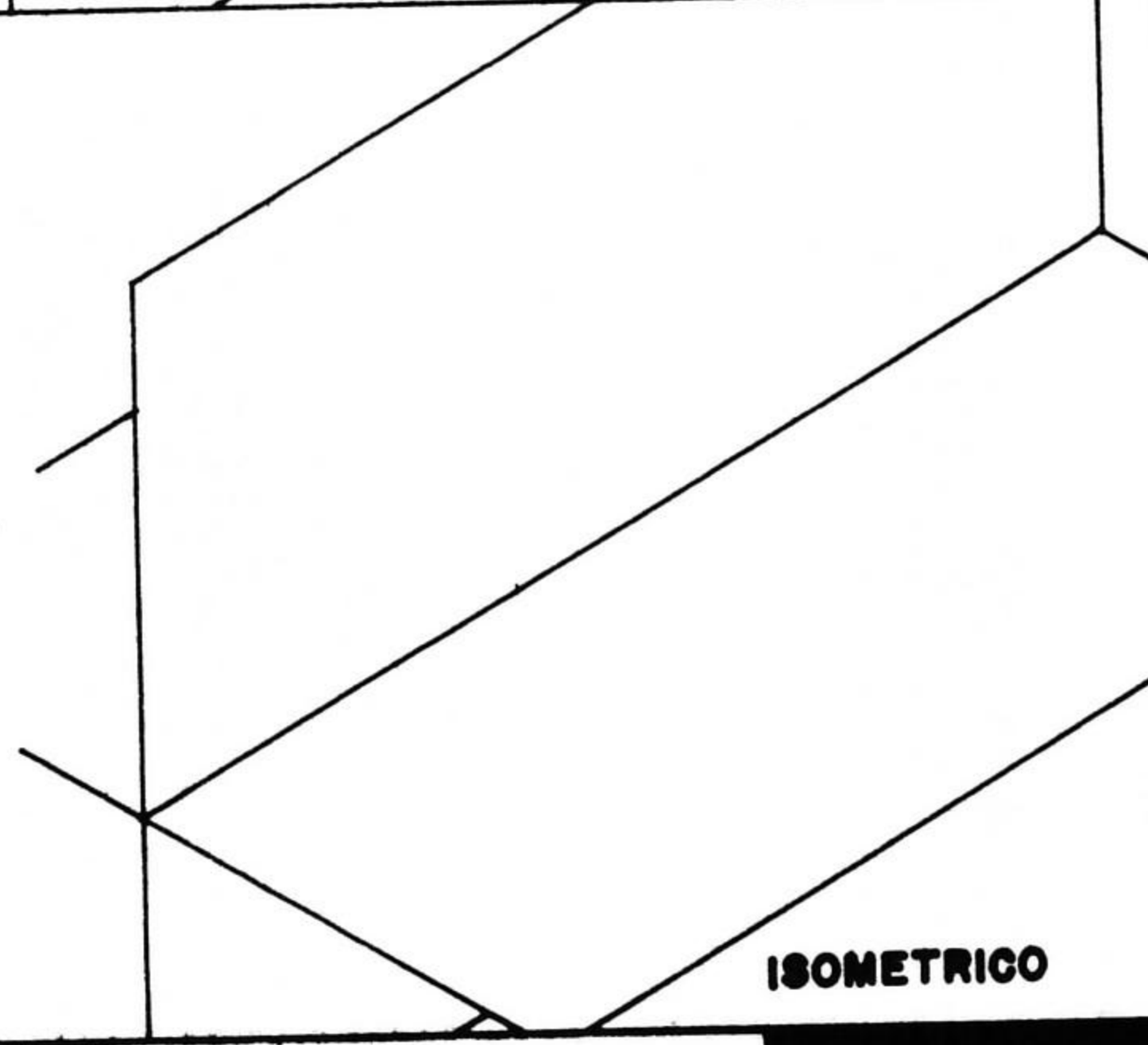
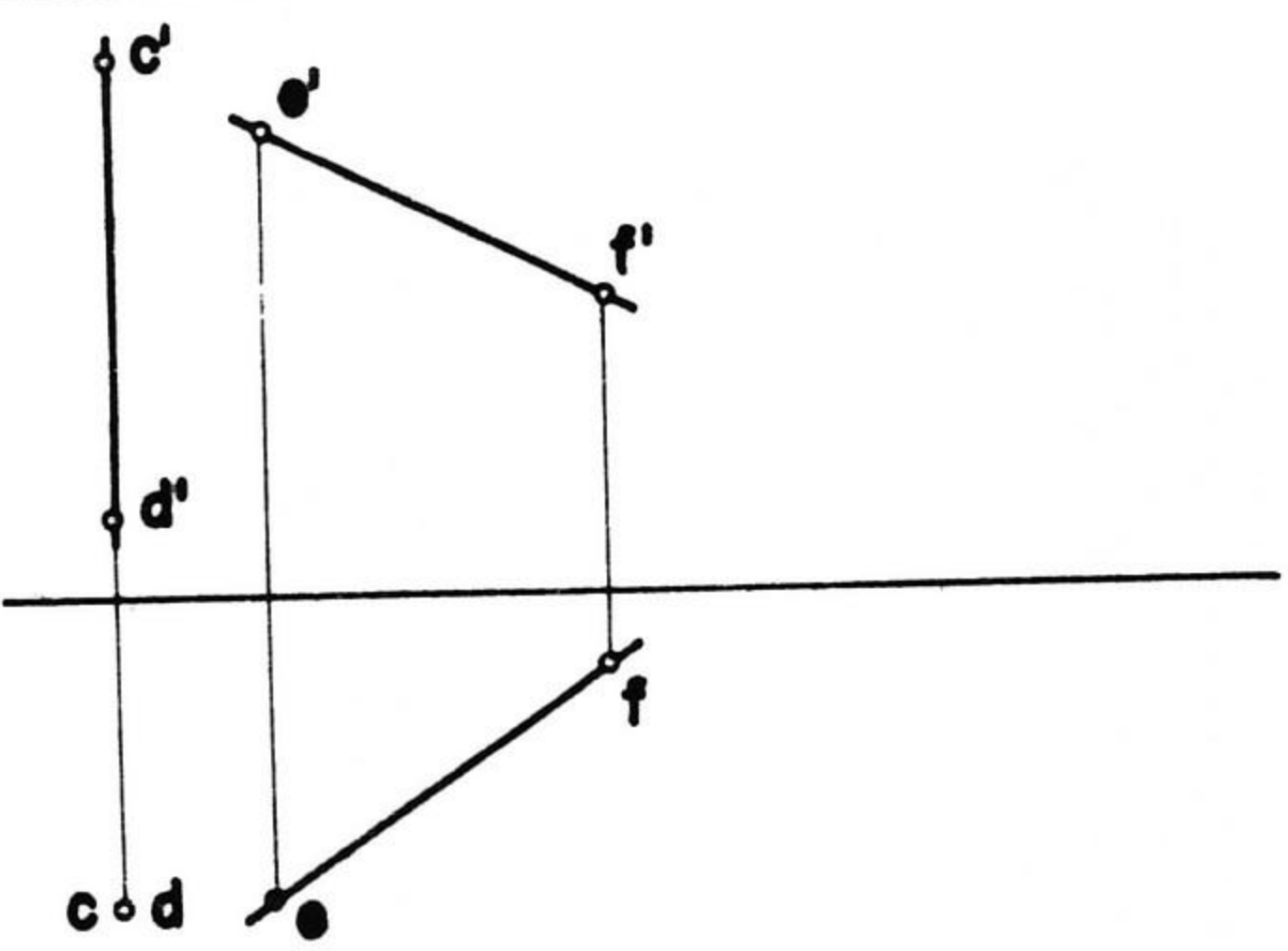

ISOMETRICO

DPTO. DISEÑO BASICO		ISPJAE		D D D
		FACULTAD DE ARQUITECTURA		
ASIGNATURA	TEMA	No.	GPO.	
DOC.	ALUM.	EVAL.		
FECHA				

2.4.8 DADAS LAS RECTAS AB, BC, CD, DE, Y EF, POR SUS PROYECCIONES ORTOGONALES. INTERPRETAR SUS PROYECCIONES Y EXPRESAR EL MODO EN QUE SE PERCIBEN EN CADA PROYECCION SEGUN LA NOTACION ESTABLECIDA.

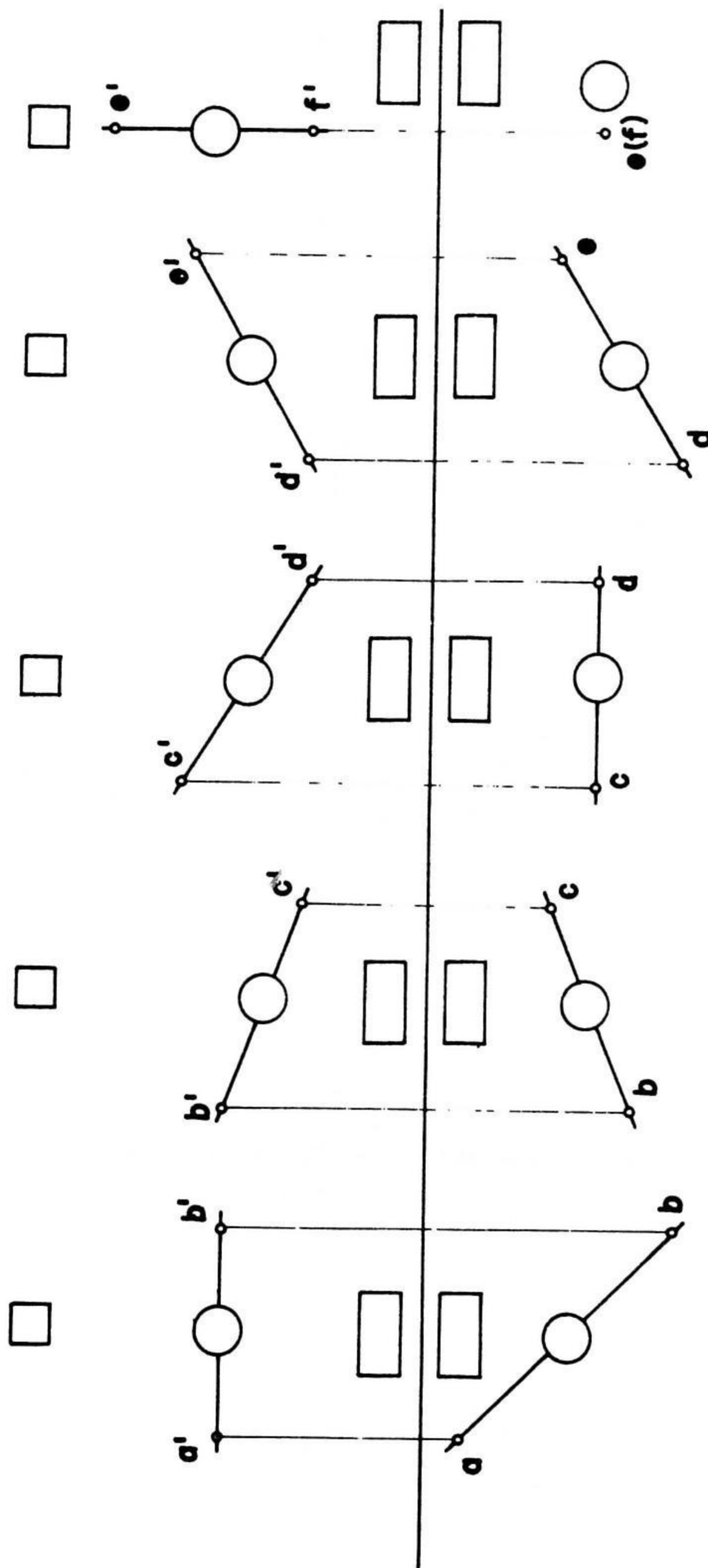

NOTACION :

- POSICION BASICA
- POSICION RELATIVA
- MODO DE PERCIBIR LA RECTA EN CADA PROYECCION

HORIZONTAL
 VERTICAL
 INCLINADA

IIPV
 IIPV

IIPH
 IIPH

IIPV
 IIPV

IIPH
 IIPH

IIPV
 IIPV

IIPH
 IIPH

IIPV
 IIPV

FRONTAL
 EN ESCORZO
 DE PUNTA

DPTO. DISEÑO BASICO

**ISPJAE
FACULTAD DE ARQUITECTURA**

ASIGNATURA	TEMA		
DOC.	ALUM.	No.	OPC.
FECHA		EVAL.	

2.5.5 DETERMINAR LAS TRAZAS DEL PLANO QUE CONTIENE A LA CARA ADC.

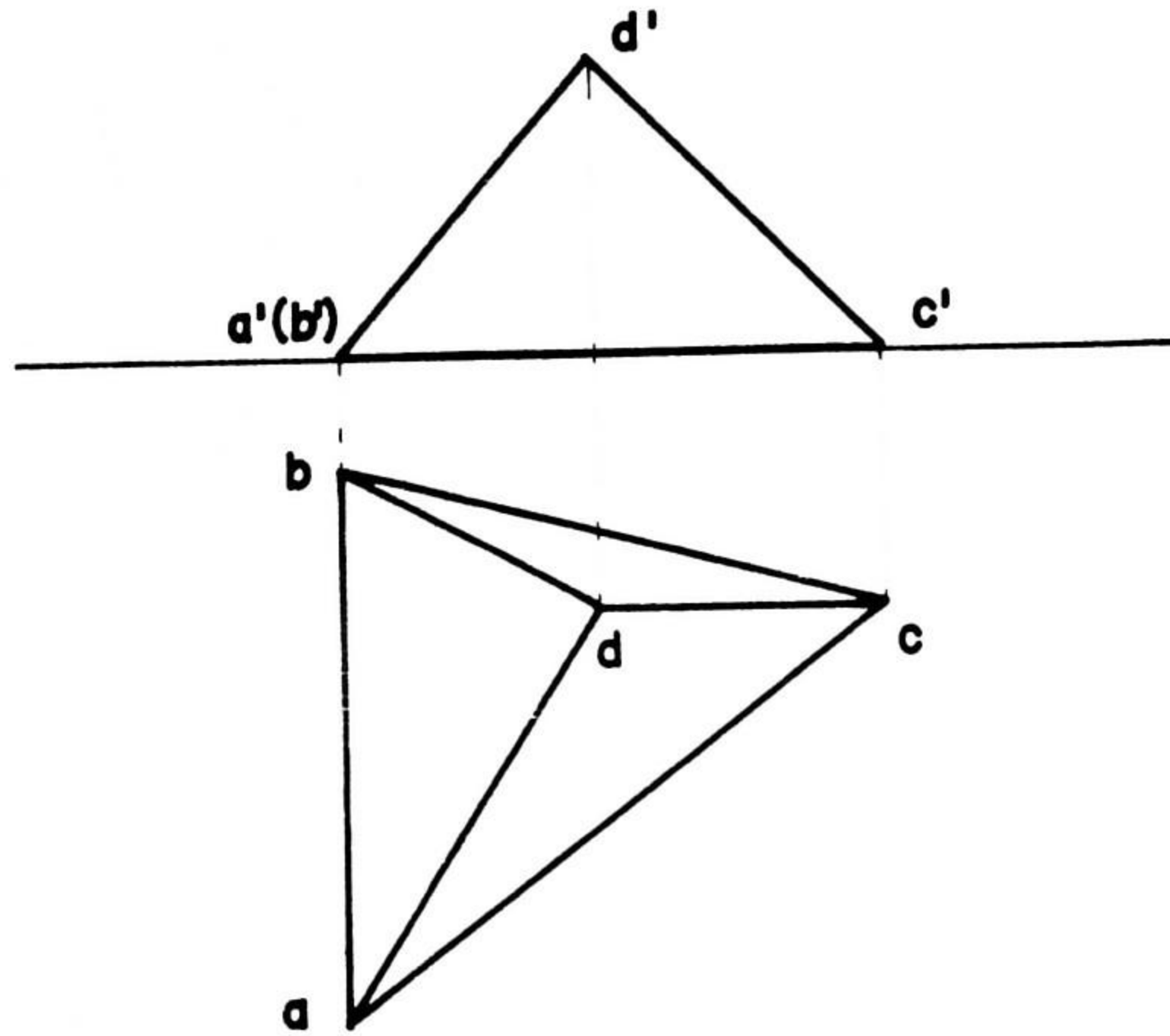

2.5.6 DETERMINAR LAS TRAZAS DEL PLANO Q QUE CONTIENE A LA CARA ABD. EXPRESE COMO SE DENOMINA ESE PLANO DADA SU POSICION CON RESPECTO AL PV.

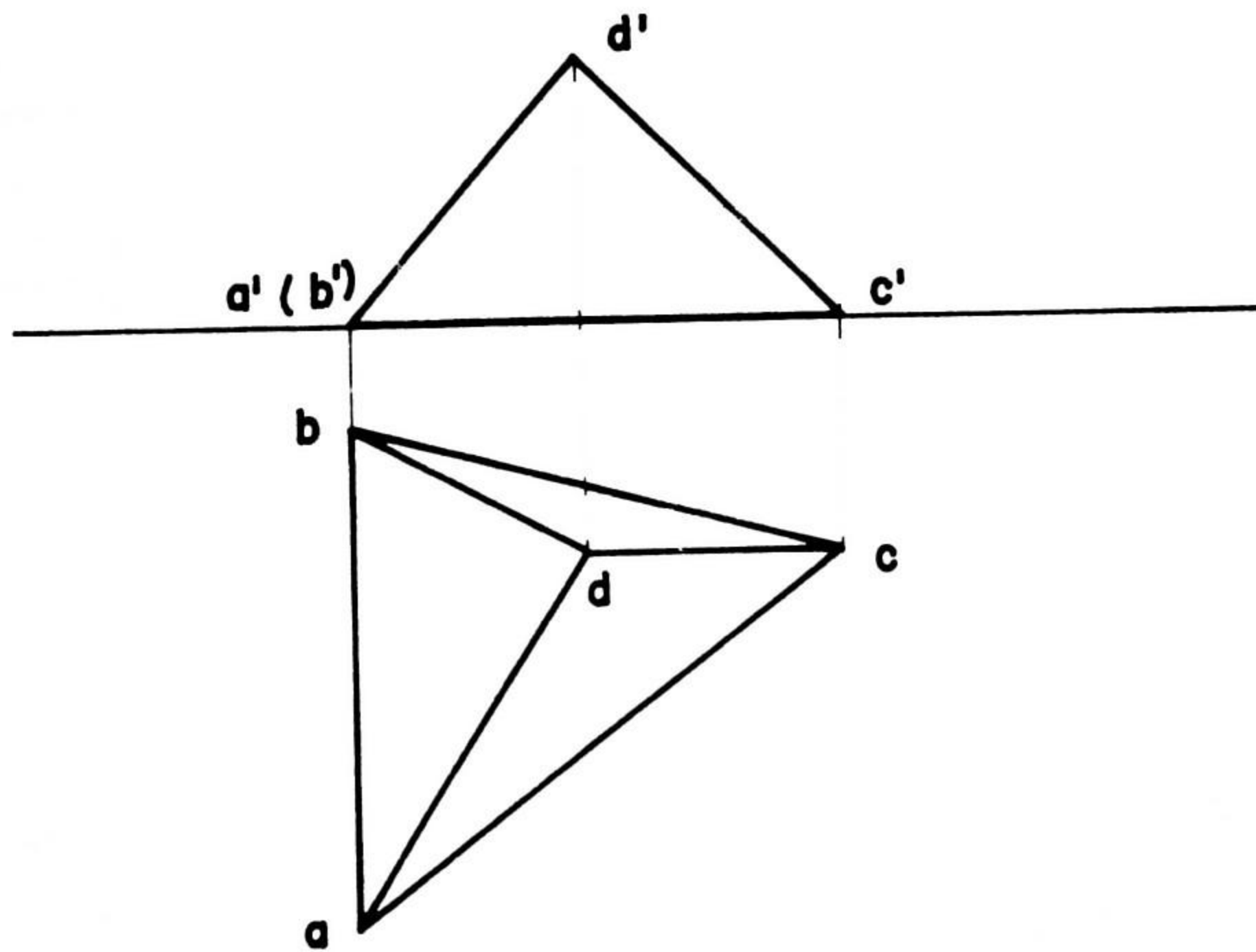

DPTO. DISEÑO BASICO		ISPJAE		FACULTAD DE ARQUITECTURA	
ASIGNATURA	TEMA				
DOC.	ALUM.		No.	OPC.	
FECHA				EVAL.	

2.5.7 RECTAS DE UN PLANO INCLINADO (OBLICUO AL PV Y AL PH)

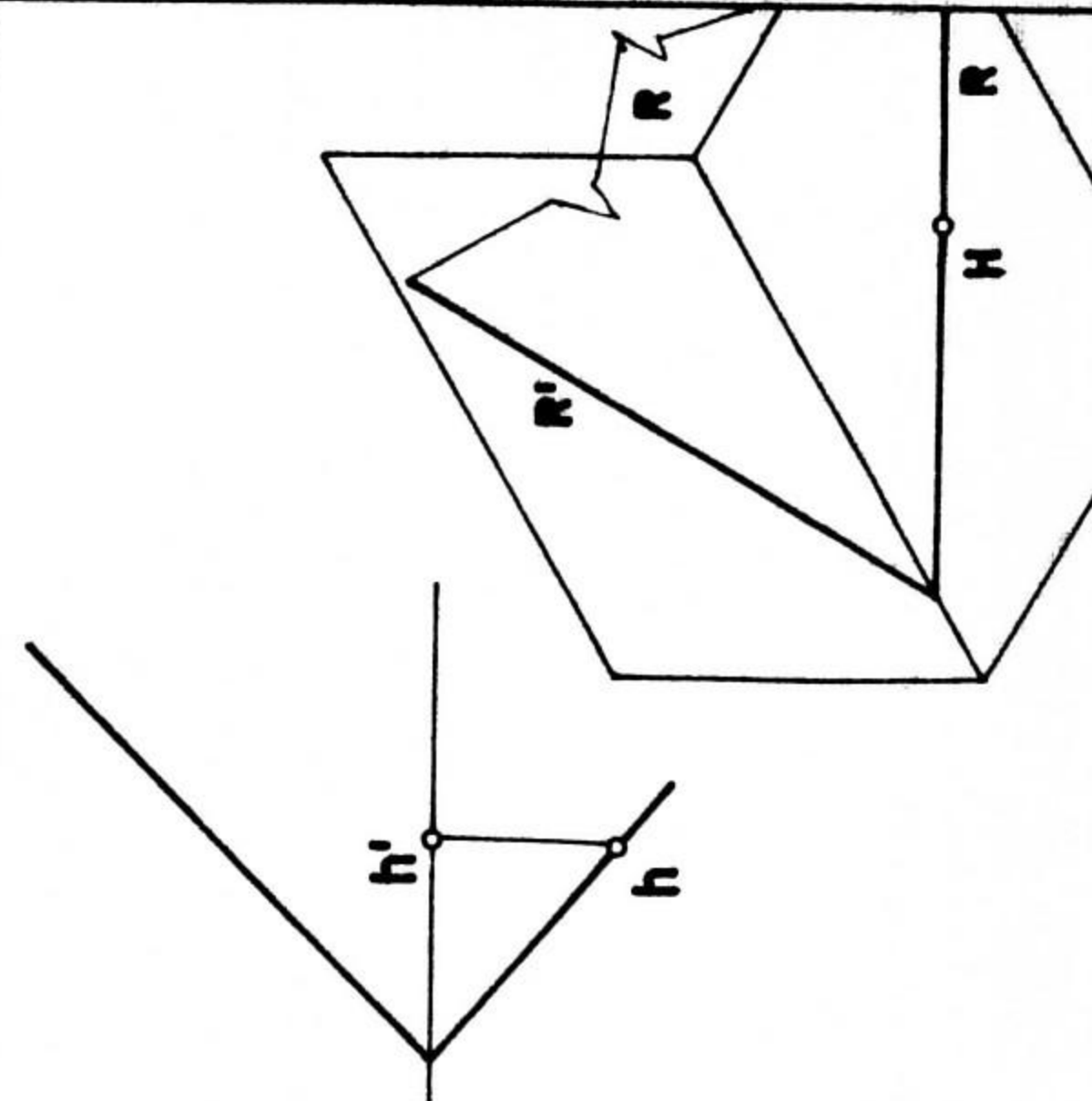
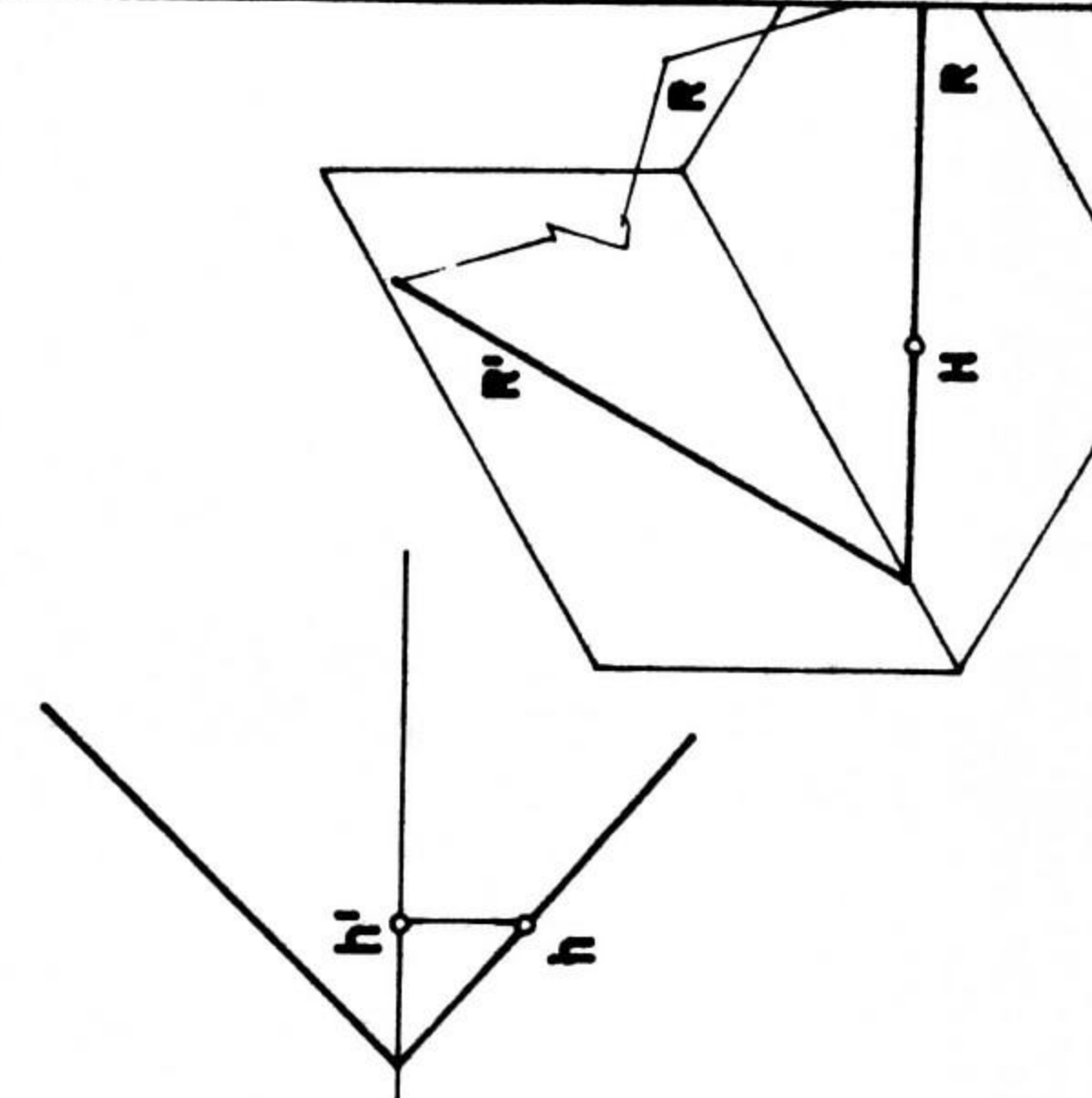
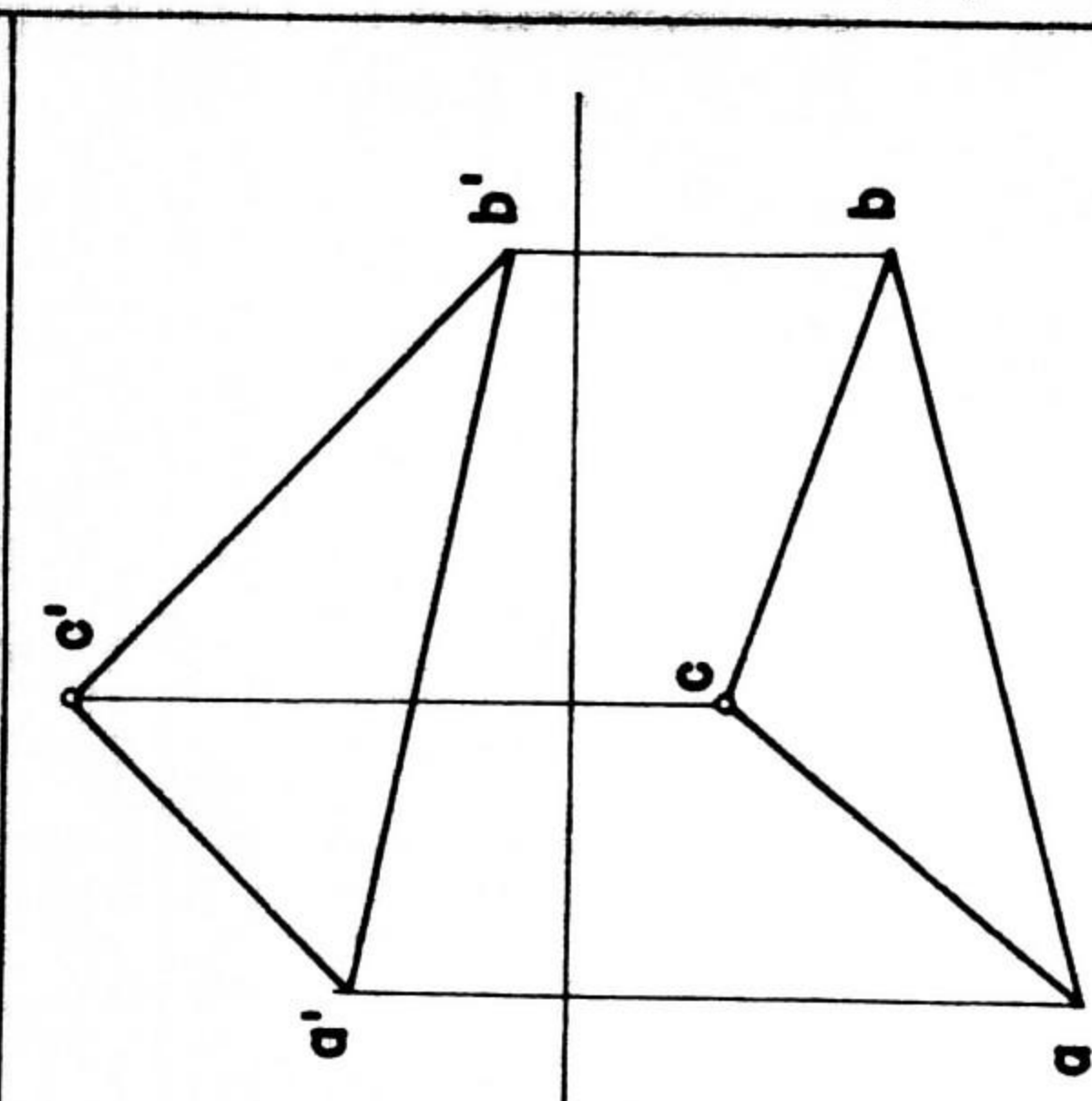
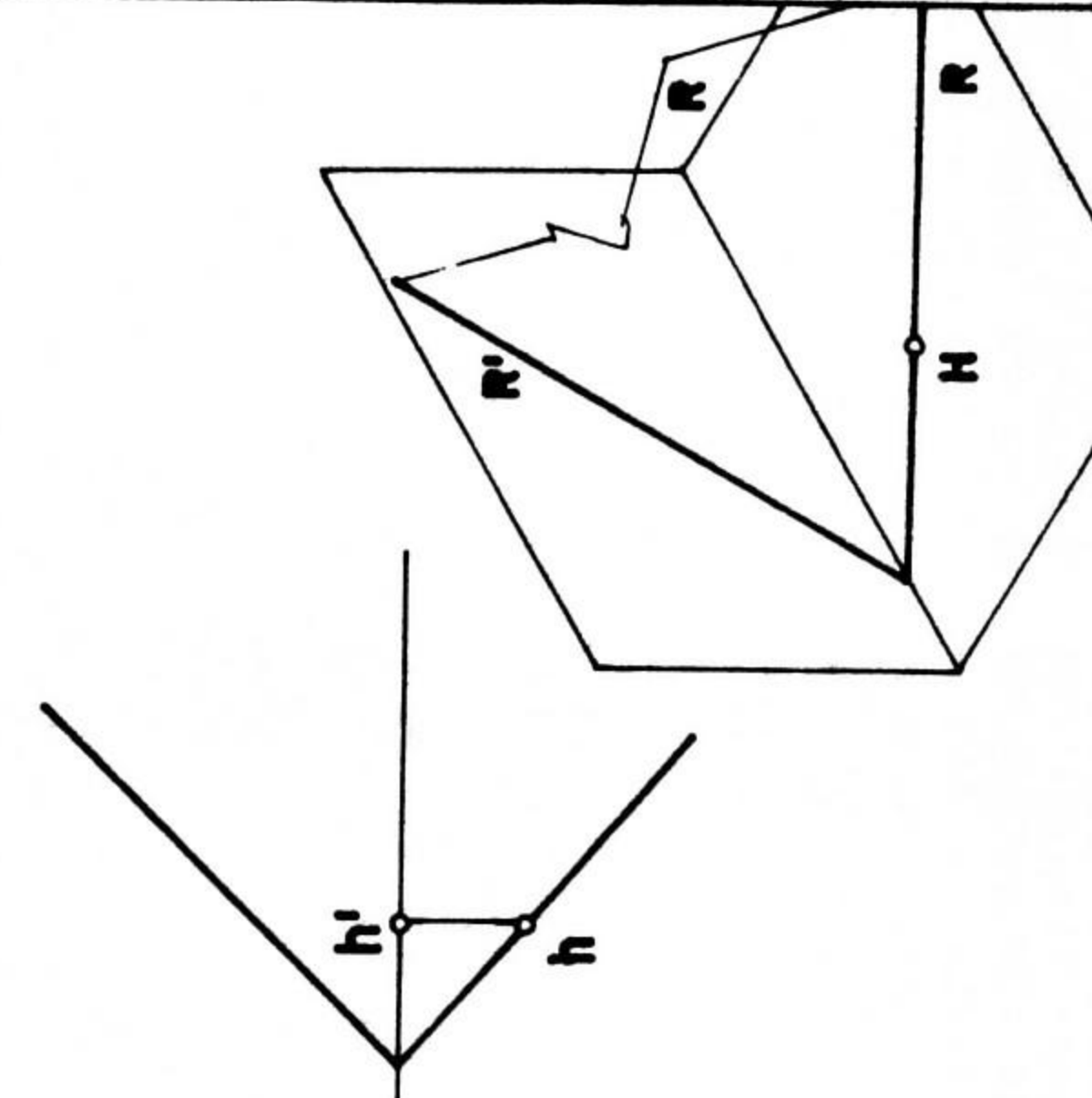
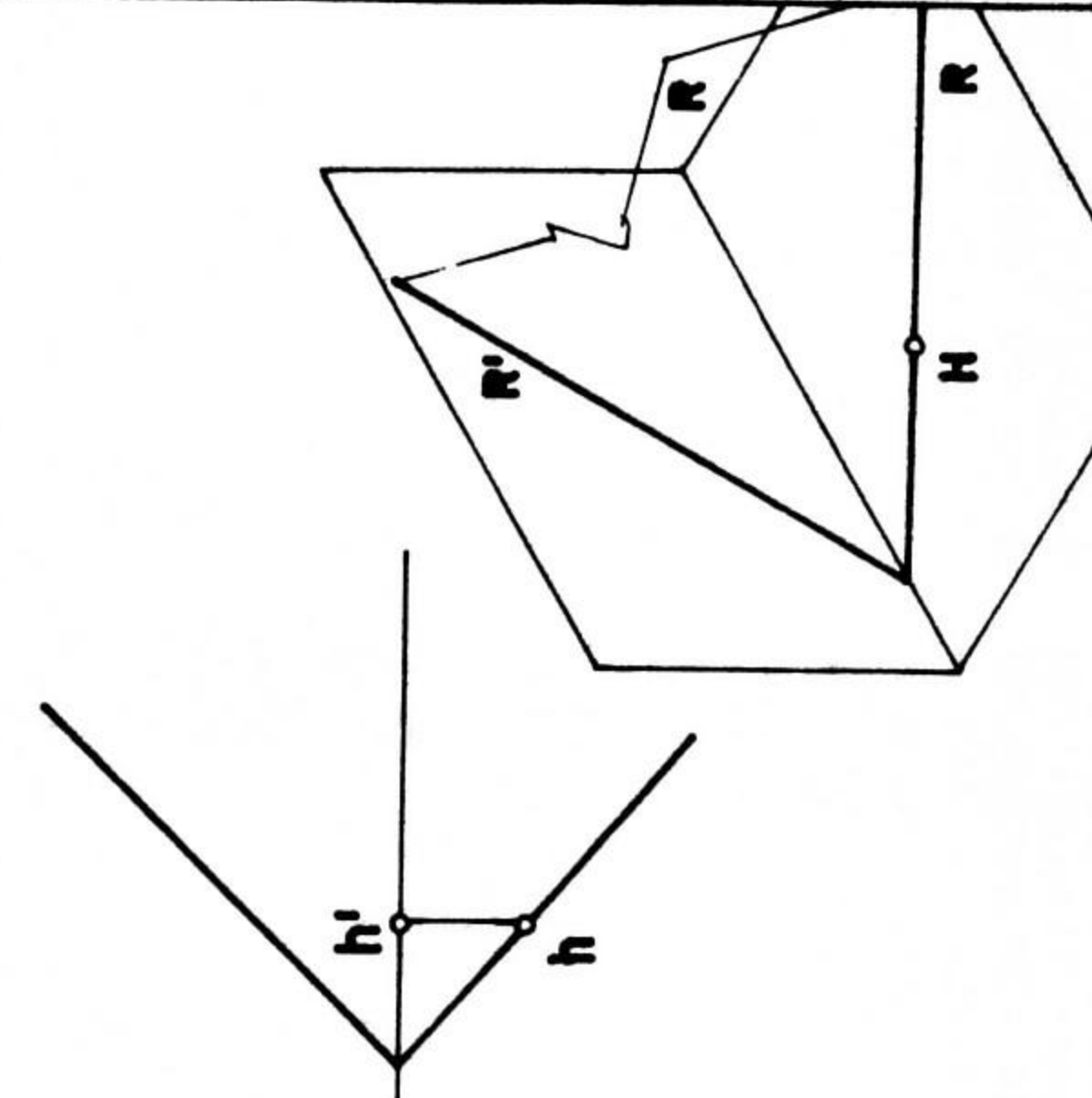
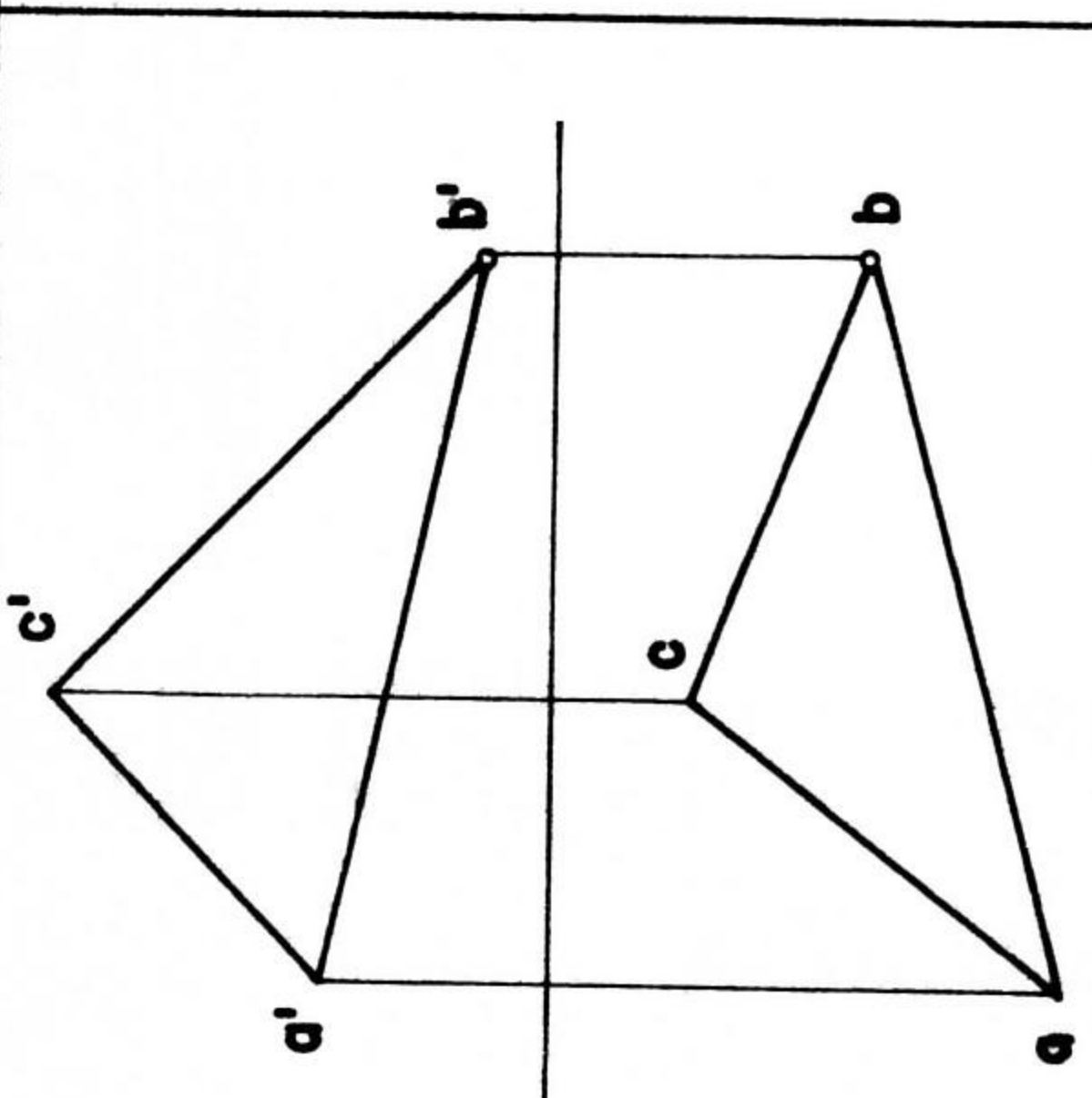
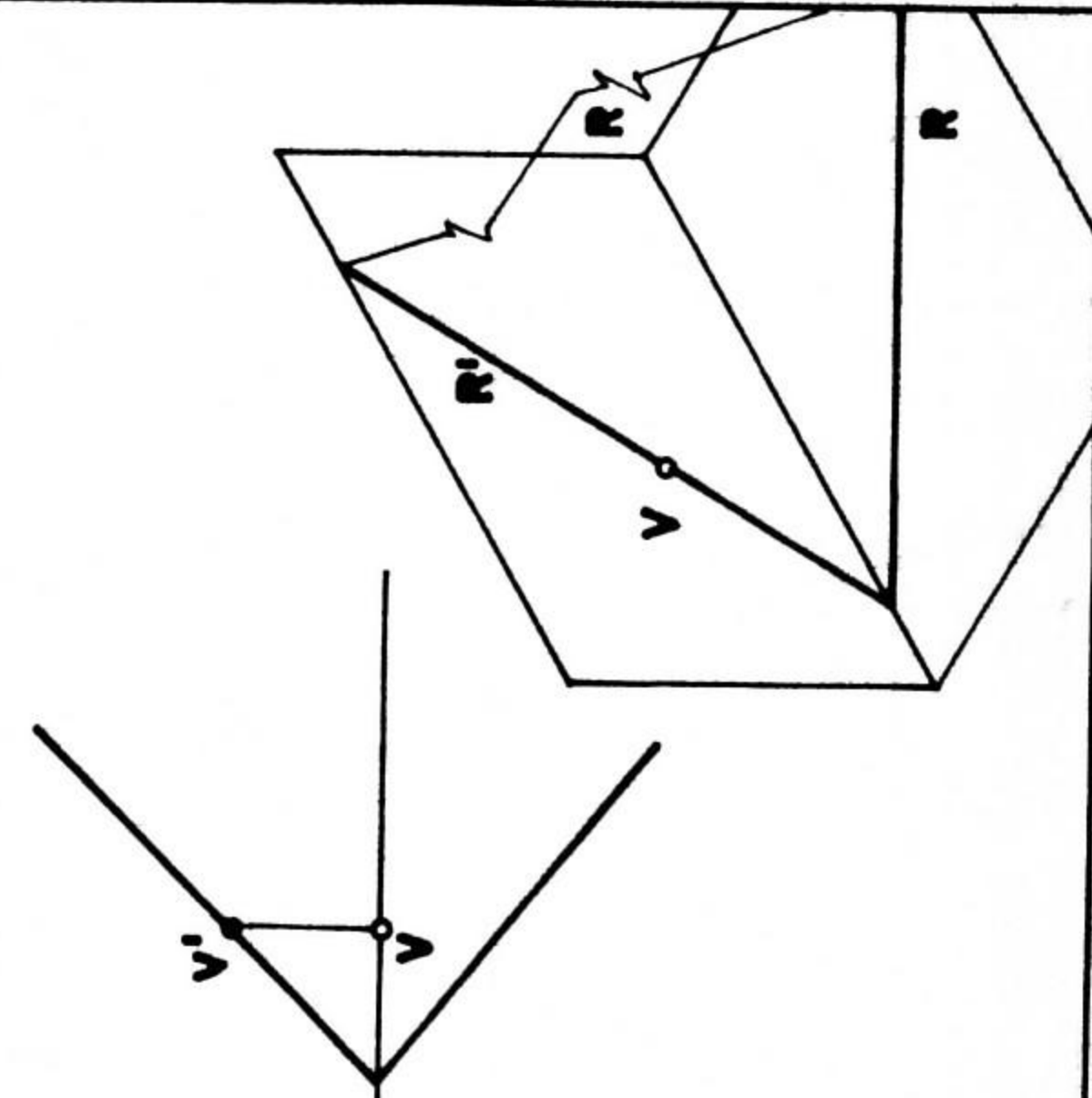
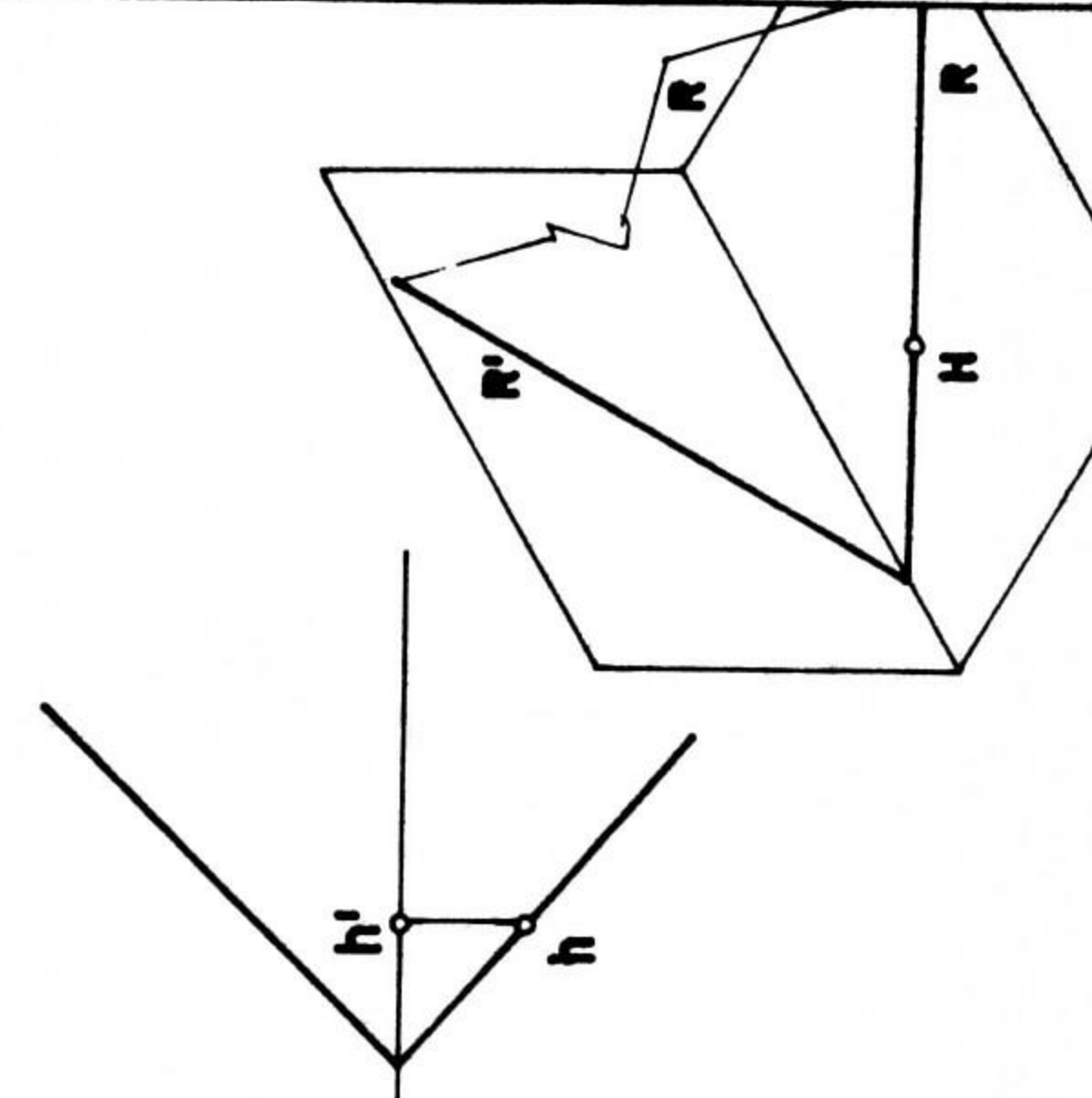
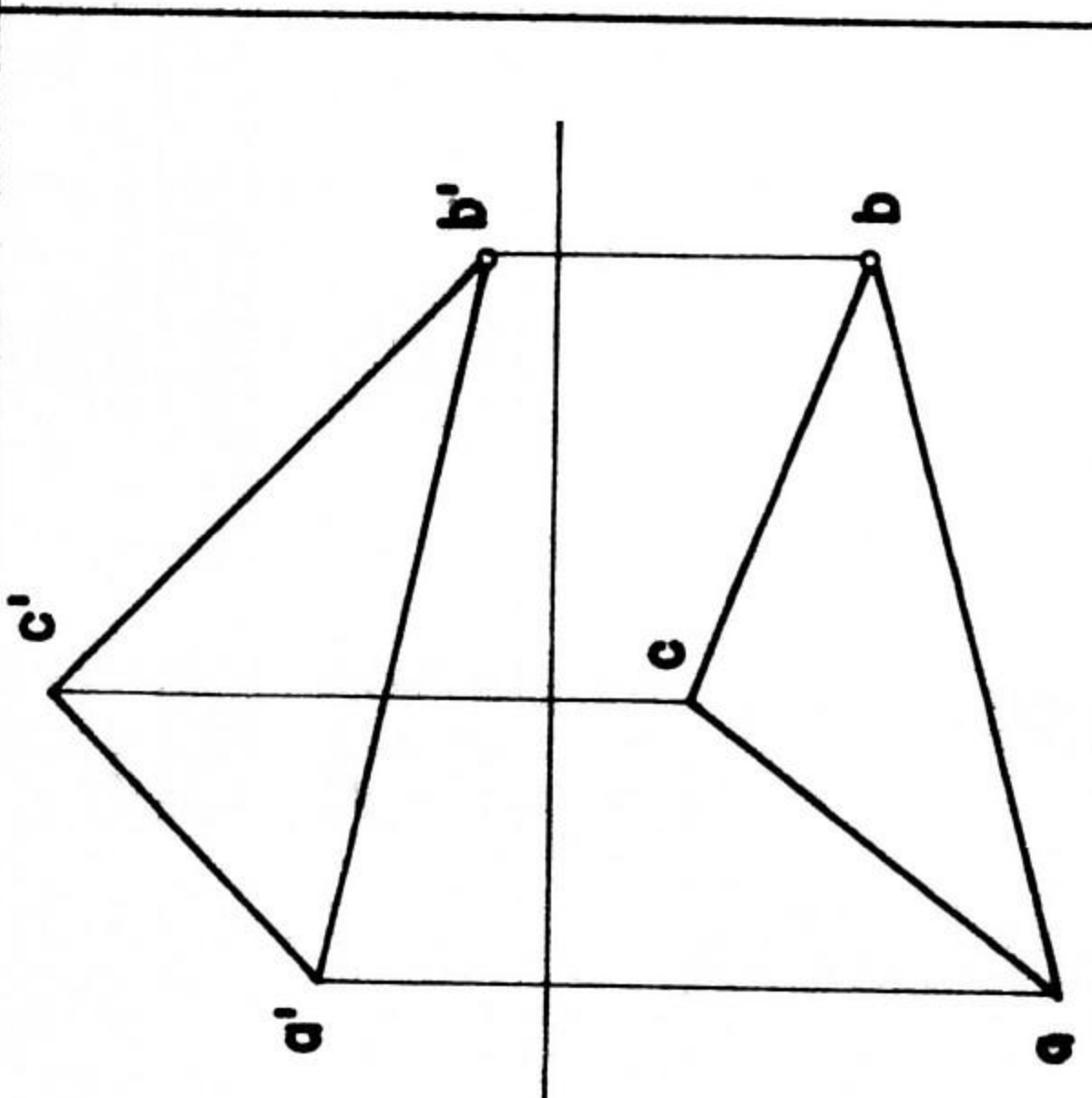
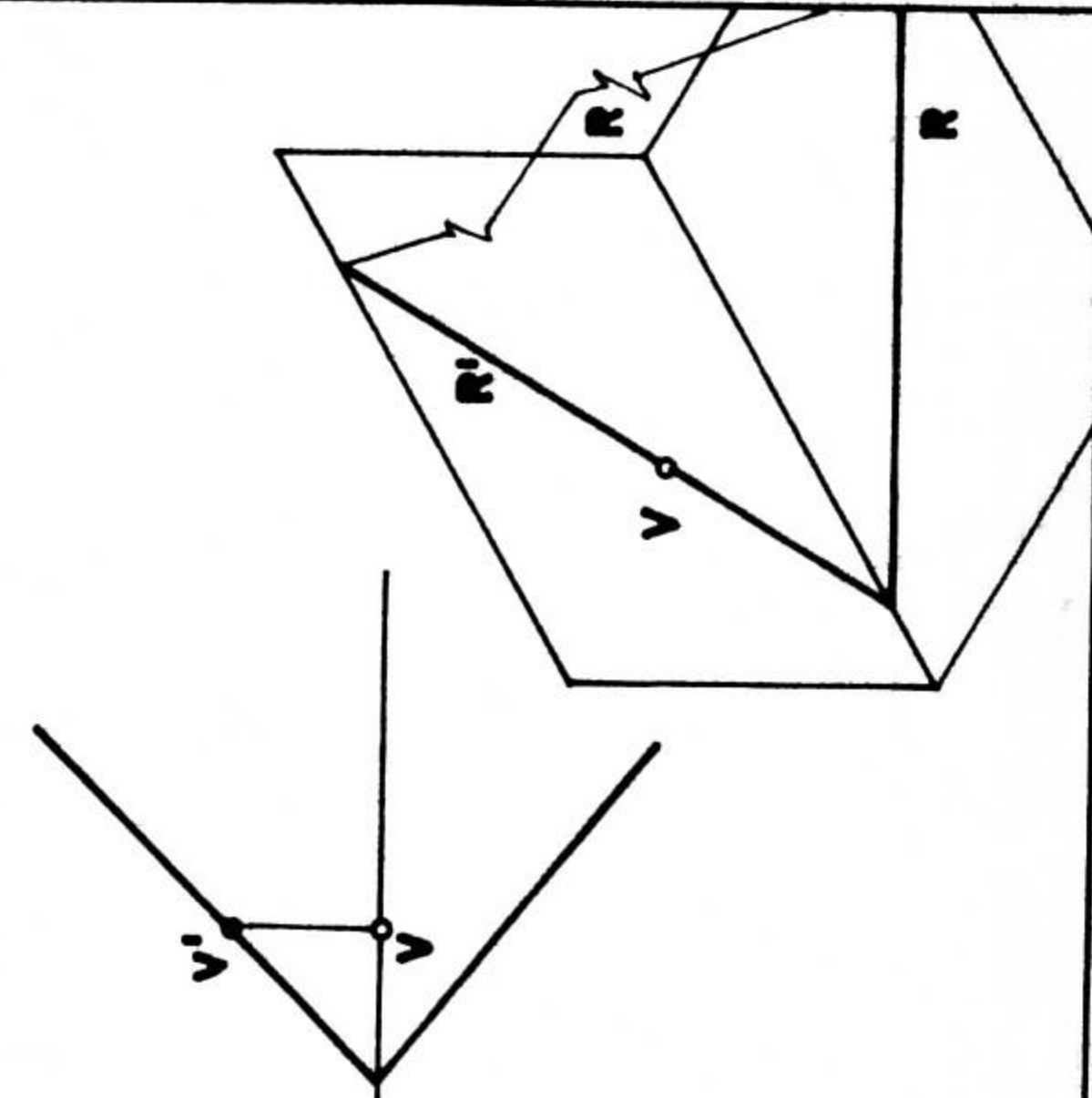
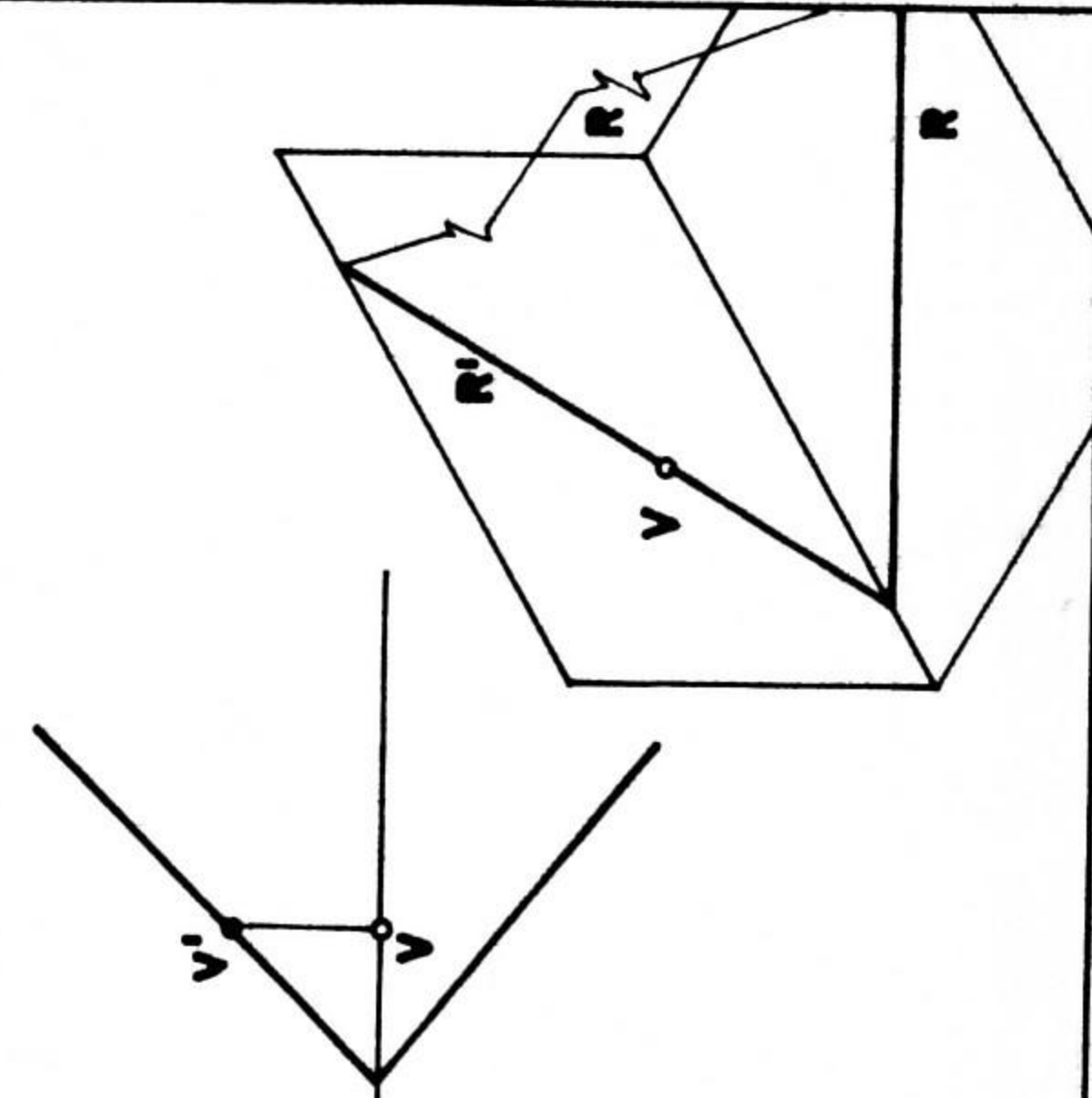
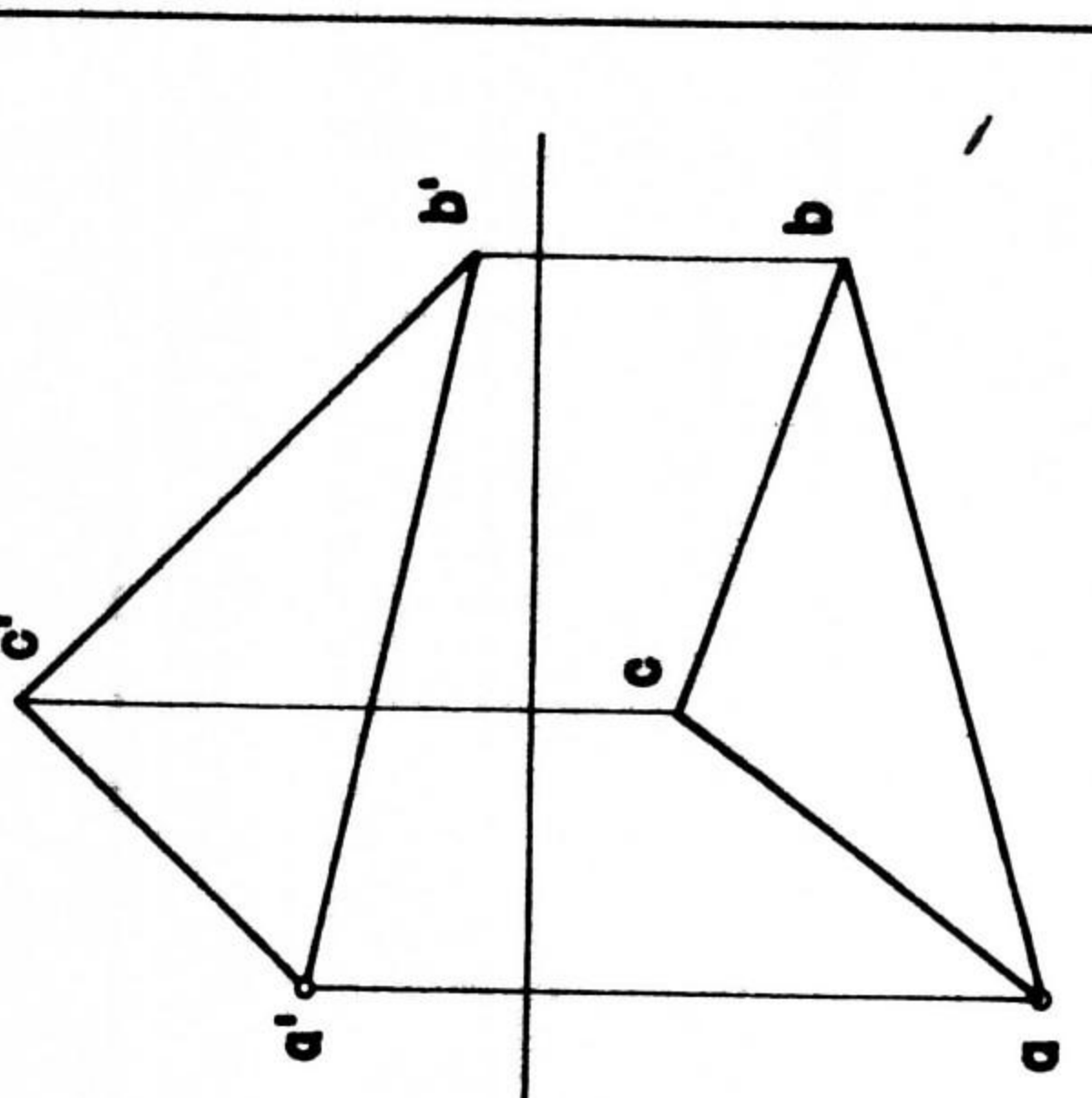
<p style="text-align: center;">TRAZAR UNA GENERATRIZ DE MAXIMA PENDIENTE POR EL PUNTO H.</p>		<p style="text-align: center;">TRAZAR UNA GENERATRIZ INCLINADA PARALELA AL PV, POR EL PUNTO B.</p>		<p style="text-align: center;">TRAZAR UNA GENERATRIZ DE MAXIMA PENDIENTE POR EL PUNTO C.</p>	
<p style="text-align: center;">TRAZAR UNA GENERATRIZ INCLINADA PARALELA AL PV, POR EL PUNTO H.</p>		<p style="text-align: center;">TRAZAR UNA GENERATRIZ INCLINADA PARALELA AL PV, POR EL PUNTO B.</p>		<p style="text-align: center;">TRAZAR UNA GENERATRIZ DE MAXIMA PENDIENTE POR EL PUNTO C.</p>	
<p style="text-align: center;">TRAZAR UNA GENERATRIZ HORIZONTAL POR EL PUNTO V.</p>		<p style="text-align: center;">TRAZAR UNA GENERATRIZ INCLINADA PARALELA AL PV, POR EL PUNTO B.</p>		<p style="text-align: center;">TRAZAR UNA GENERATRIZ DE MAXIMA PENDIENTE POR EL PUNTO C.</p>	
<p style="text-align: center;">TRAZAR UNA GENERATRIZ HORIZONTAL POR EL PUNTO V.</p>		<p style="text-align: center;">TRAZAR UNA GENERATRIZ HORIZONTAL POR EL PUNTO A.</p>		<p style="text-align: center;">TRAZAR UNA GENERATRIZ DE MAXIMA PENDIENTE POR EL PUNTO C.</p>	

DPTO. DISEÑO BASICO		ISPJAE		FACULTAD DE ARQUITECTURA	
ASIGNATURA	TEMA				
DOC.	ALUM.	No.	GPO.		
FECHA			EVAL.		

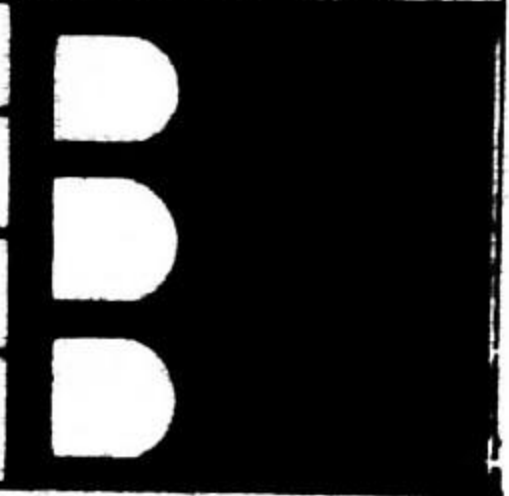

2.5.8 FIGURAS PLANAS VERTICALES

DETERMINAR LAS FORMAS APARENTES A PARTIR DE LAS PROYECCIONES HORIZONTALES Y DATOS RESTANTES.
IDENTIFICAR CADA PUNTO SEGUN LA NOTACION ESTABLECIDA
a) FORMA Y b) MODO DE PERCIBIR LA FIGURA EN PROYECCION VERTICAL

a			
b			
CUADRADOS			

DPTO. DISEÑO BASICO

ISPJAE
FACULTAD DE ARQUITECTURA

ASIGNATURA

TEMA

DOC.

ALUM.

No.

OPC.

FECHA

EVAL.



3.1 RELACIONES ENTRE PUNTO, RECTA Y PLANO

F DETERMINAR LA OTRA PROYECCION DEL SEGMENTO \overline{AB} , SITUADO EN EL PLANO Q.

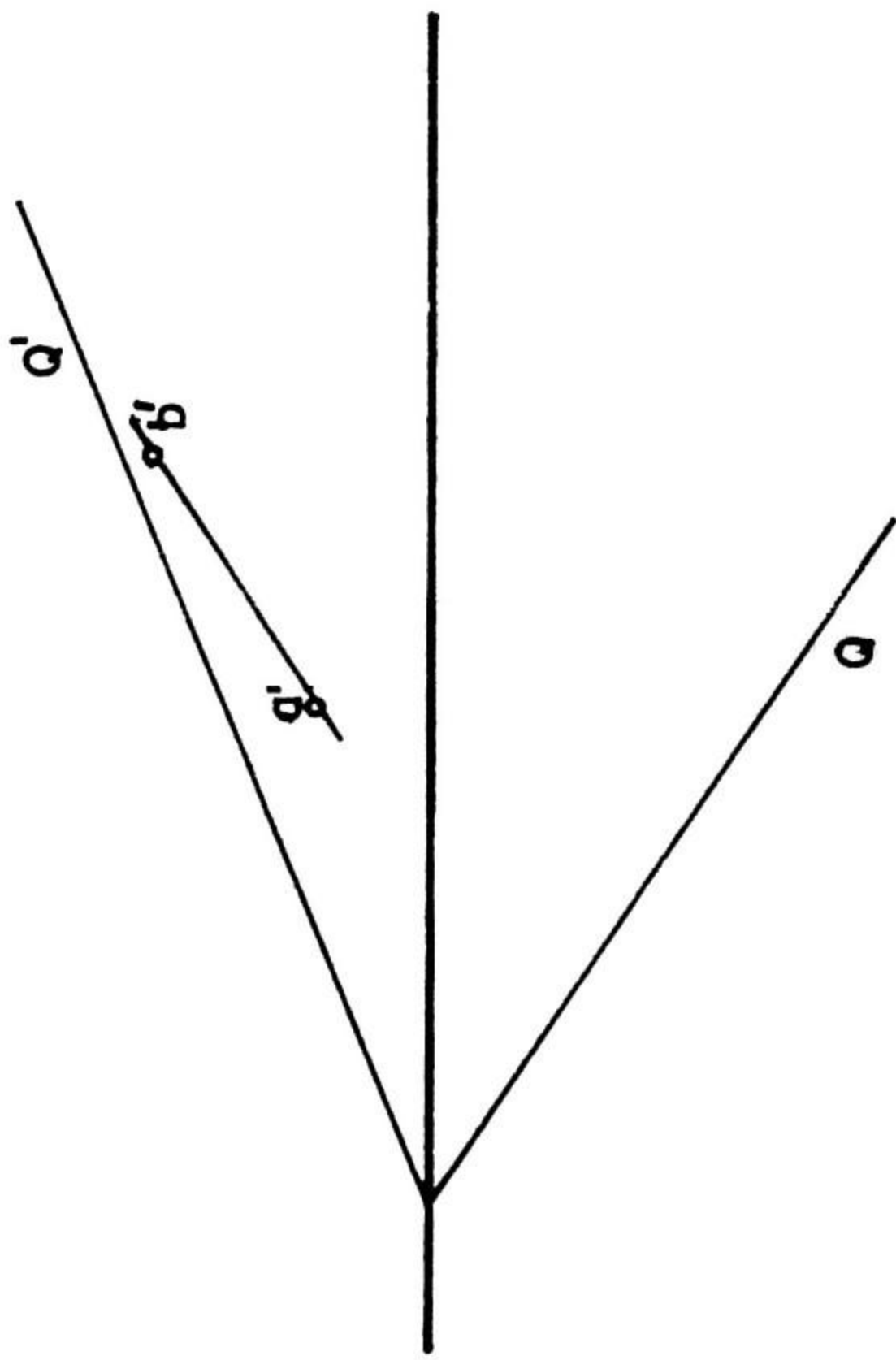

H DETERMINAR LA OTRA PROYECCION DEL PUNTO E, SITUADO EN EL PLANO DEL TRIANGULO.

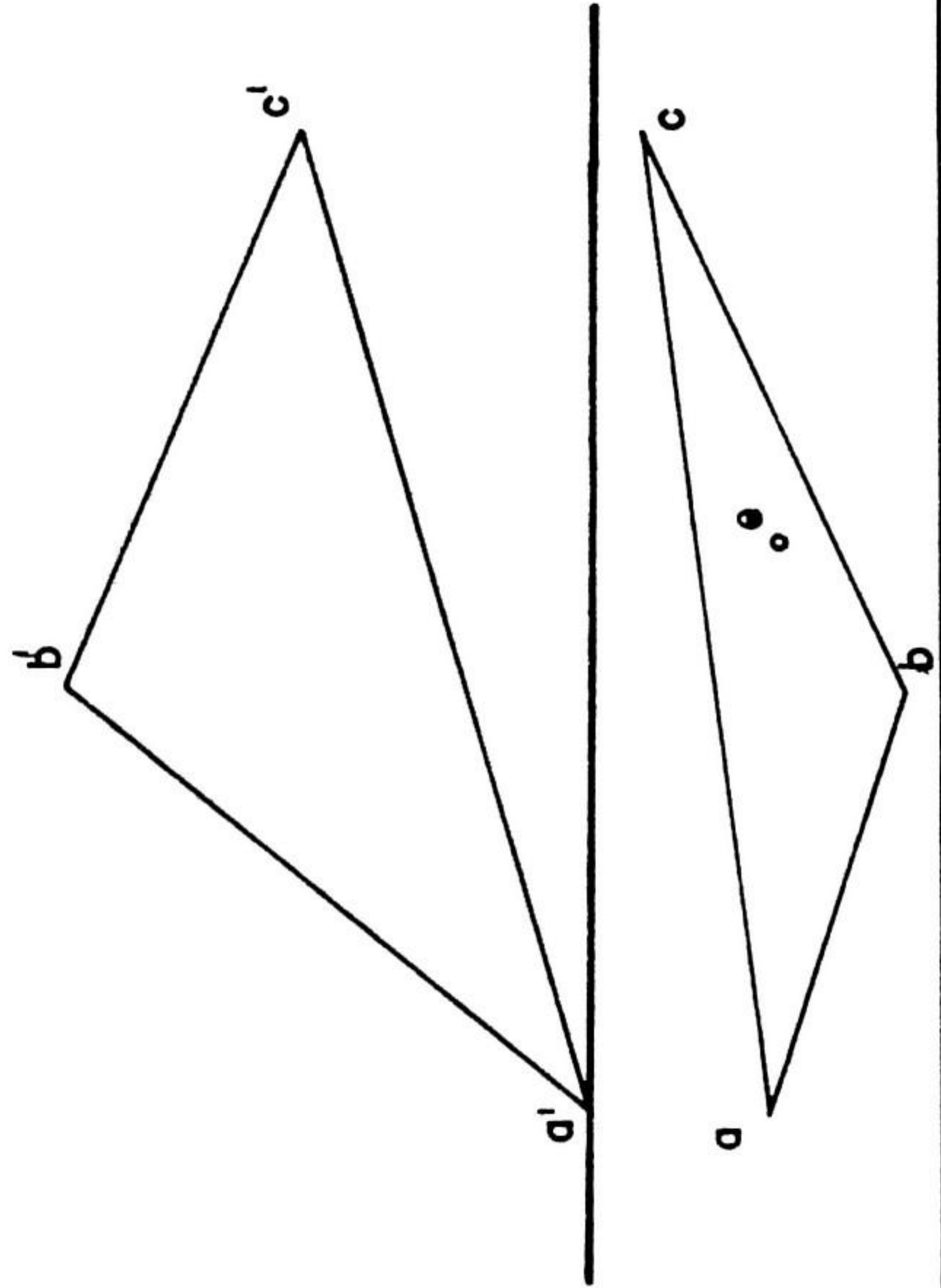

E CONSTRUIR LAS TRAZAS DE LOS PLANOS DETERMINADOS POR LAS RECTAS QUE SE CORTAN AB-CD Y EF-GH.

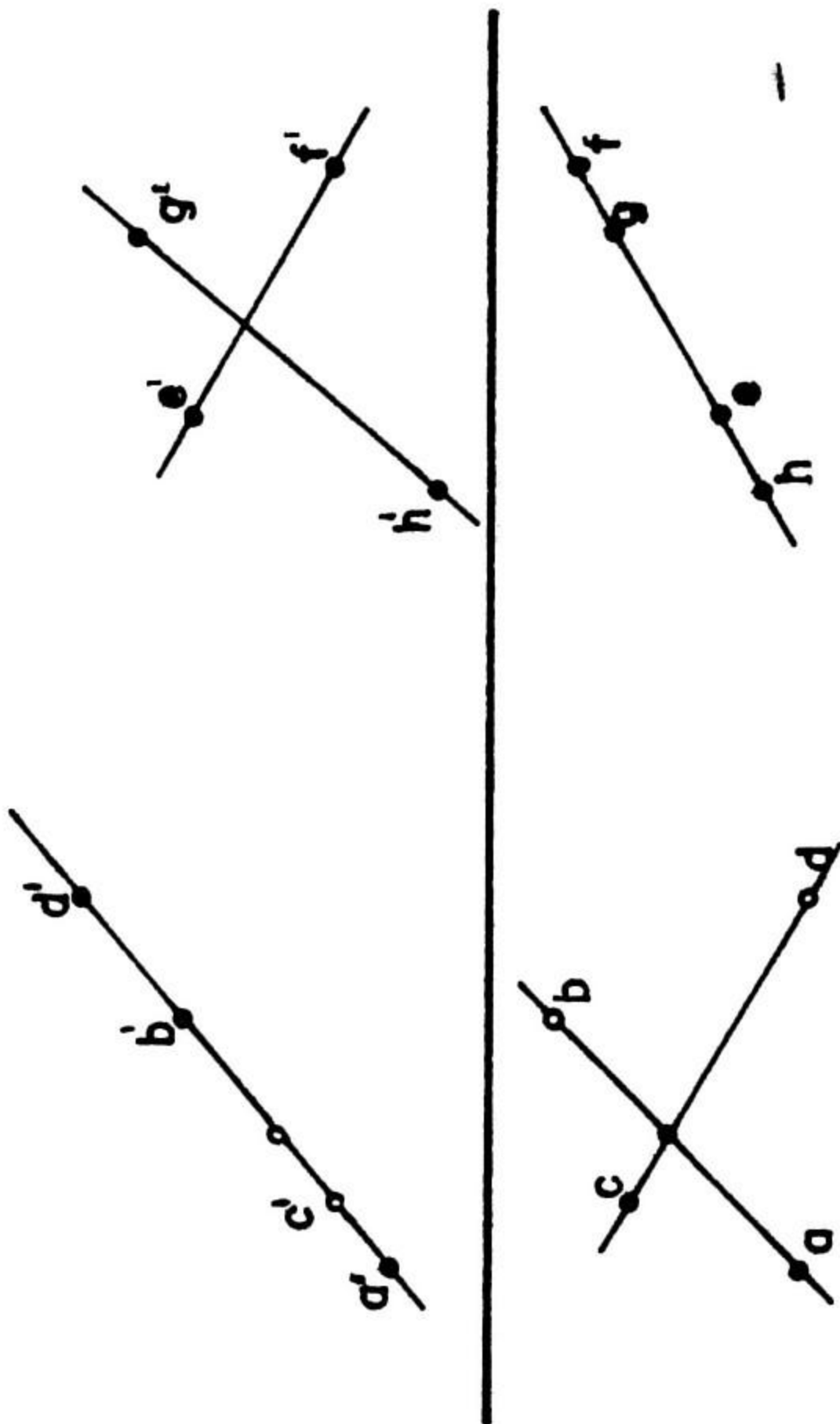

G DETERMINAR LAS TRAZAS DEL PLANO DEL TRIANGULO

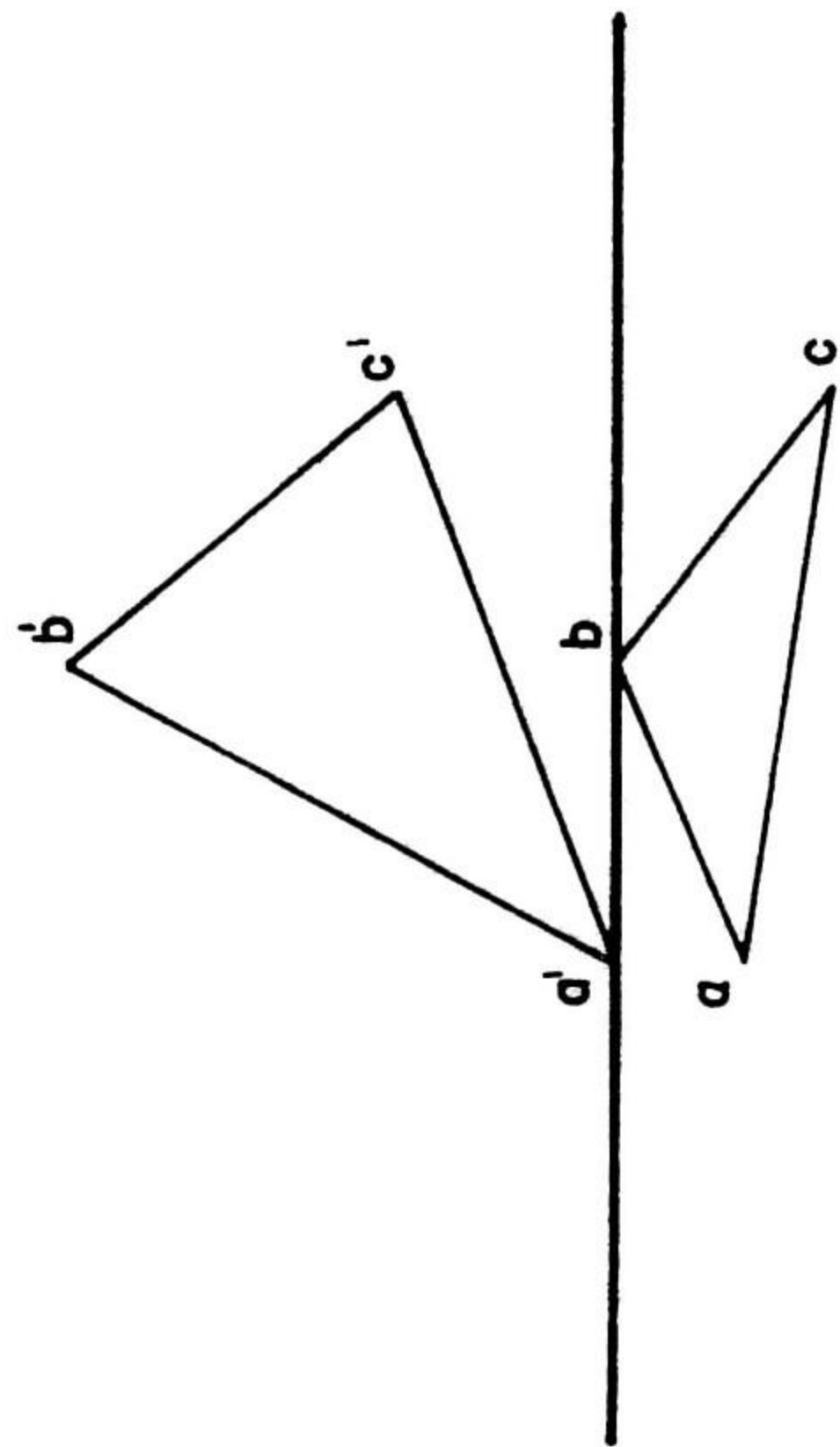

DPTO. DISEÑO BASICO

ISPJAE FACULTAD DE ARQUITECTURA

ASIGNATURA	TEMA		
DOC.	ALUM.	No.	OPC.
FECHA		EVAL.	

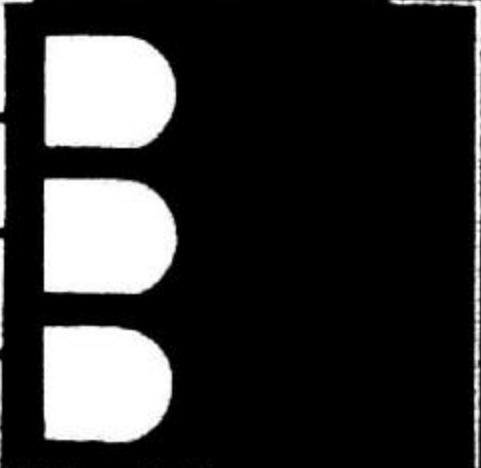

3. 4 PARALELISMO.- PROBLEMAS FUNDAMENTALES.

B TRAZAR POR EL PUNTO O UNA PARALELA A UNA GENERATRIZ HORIZONTAL DEL PLANO DEL TRIANGULO ABC.

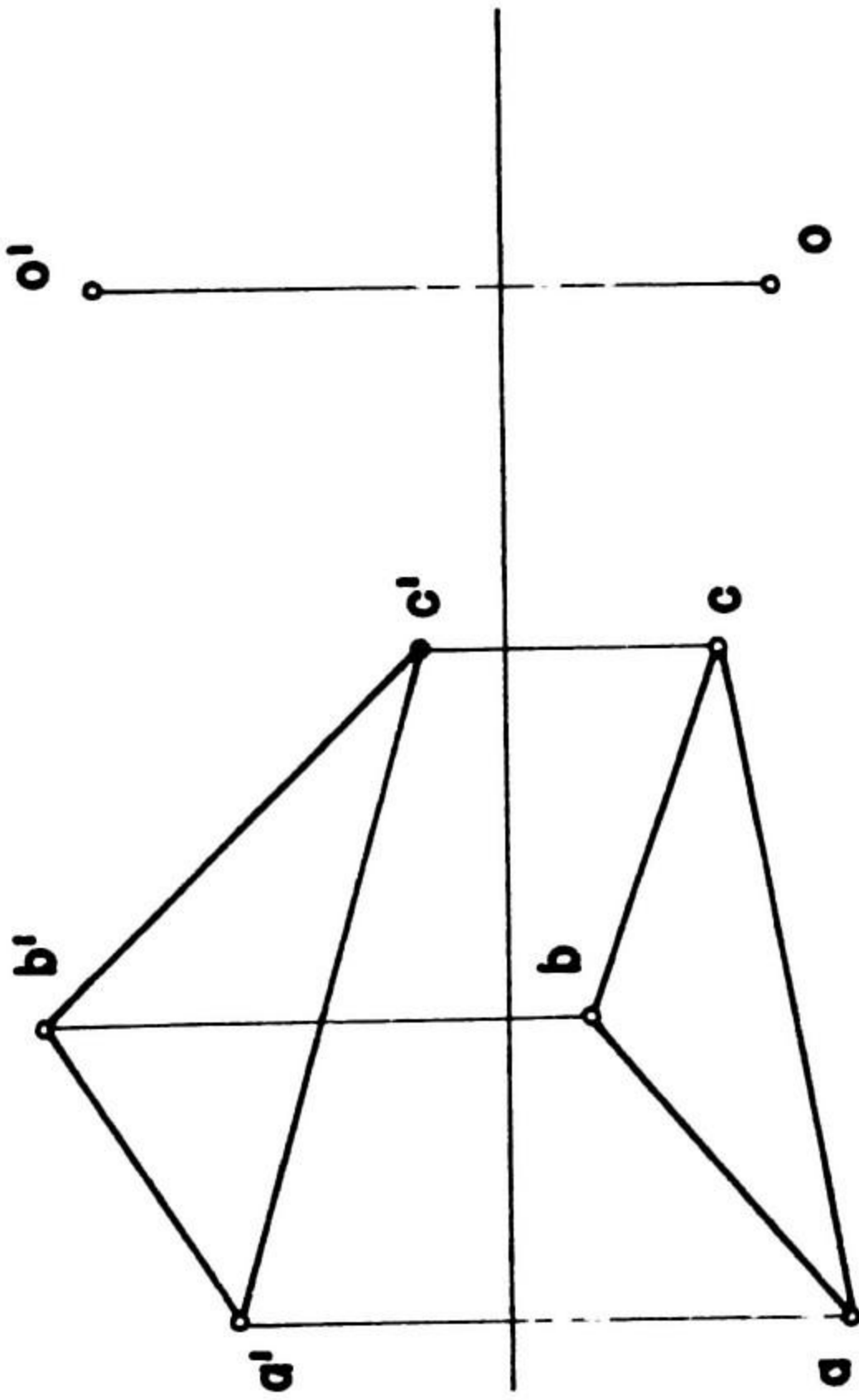

A TRAZAR POR EL PUNTO O UNA PARALELA A LA RECTA AB.

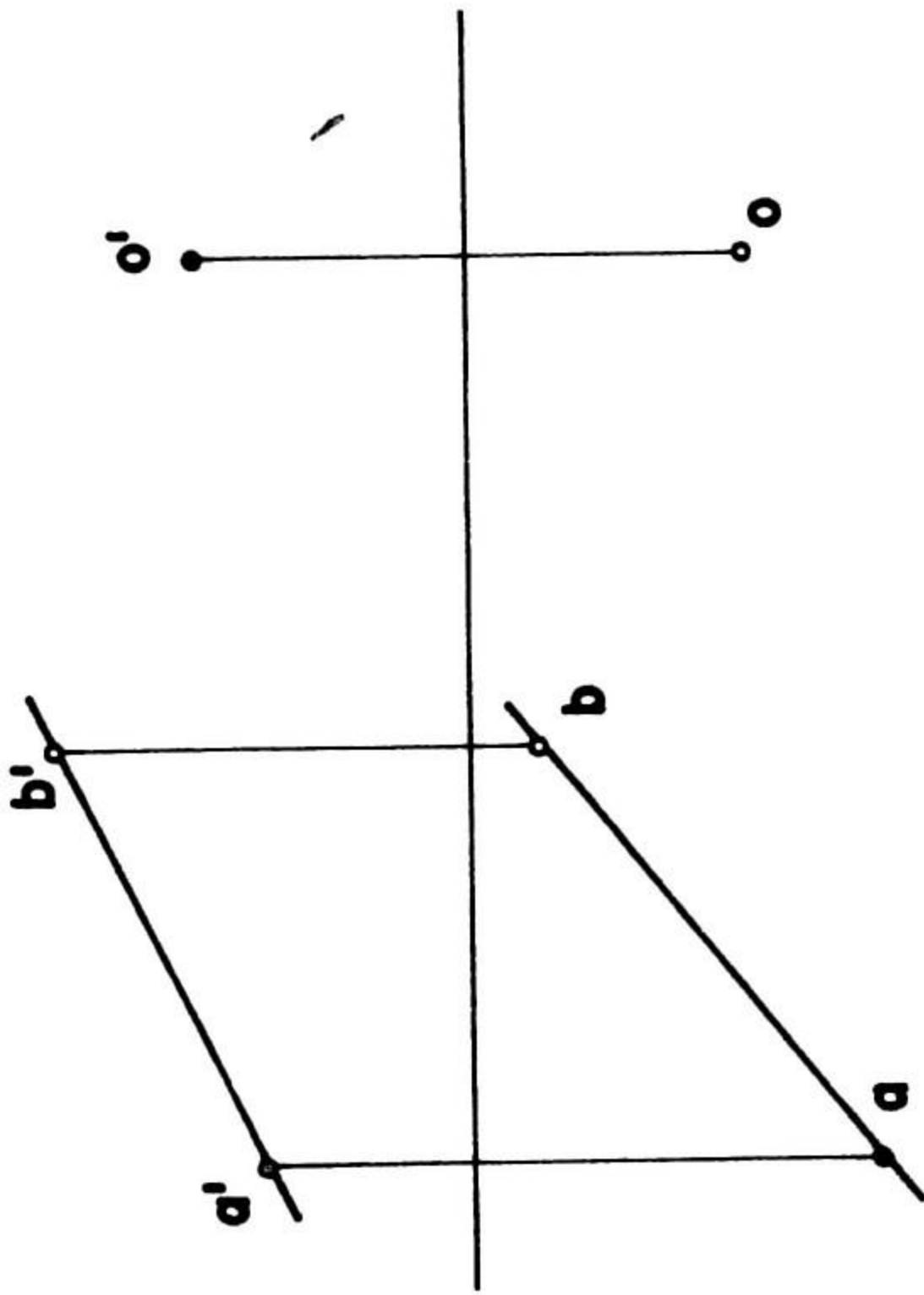

D TRAZAR POR EL PUNTO O UN PLANO PROYECTANTE PARALELO A LA RECTA AB.

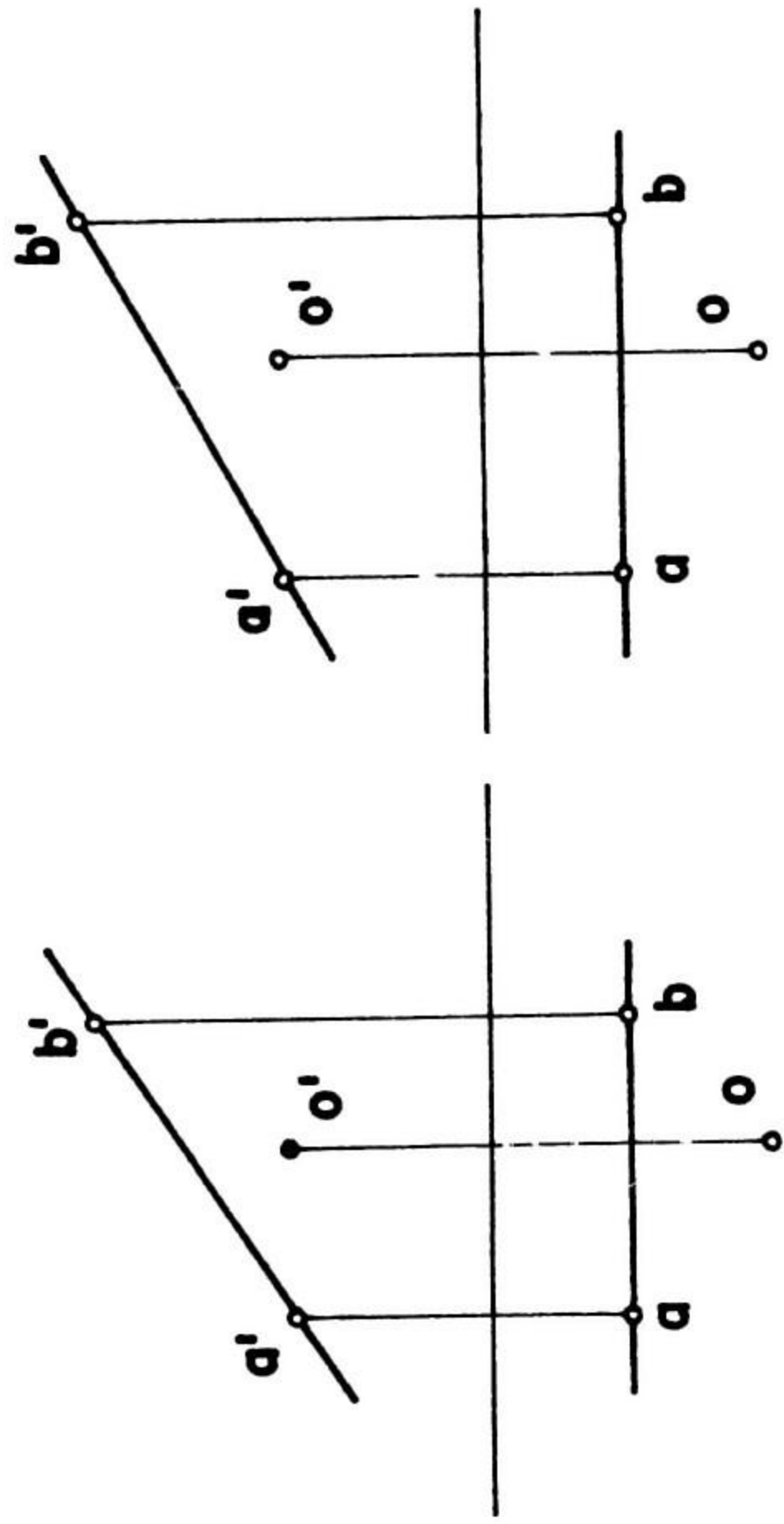

C TRAZAR POR EL PUNTO O UNA RECTA PARALELA A UNA RECTA DE MAXIMA PENDIENTE DEL PLANO P-P'

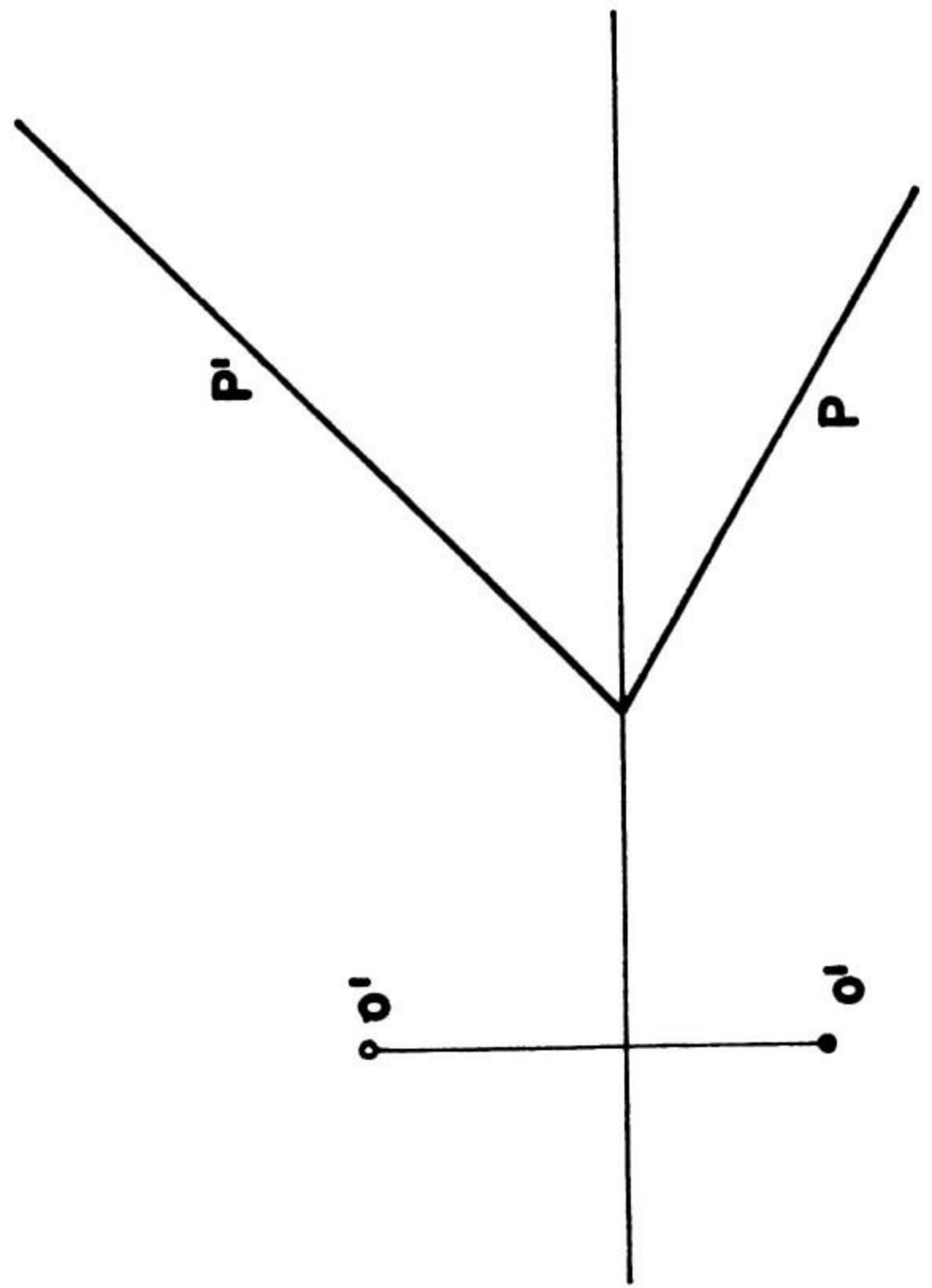

DPTO. DISEÑO BASICO

ISPJAE FACULTAD DE ARQUITECTURA

ASIGNATURA	TEMA		
DOC	ALUM.	No.	GPO.
FECHA		EVAL.	

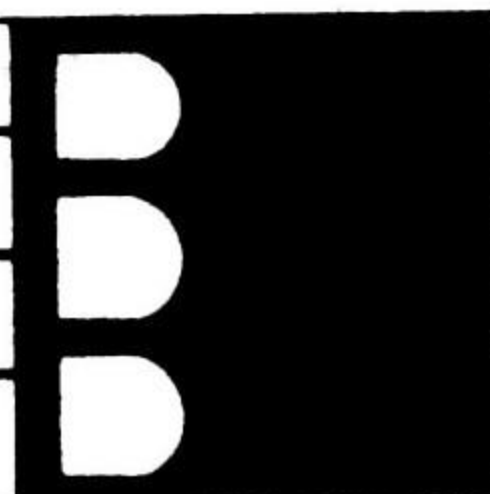

3.5.3 PERPENDICULARIDAD

B TRAZAR POR EL PUNTO E UNA RECTA PERPENDICULAR A AB.

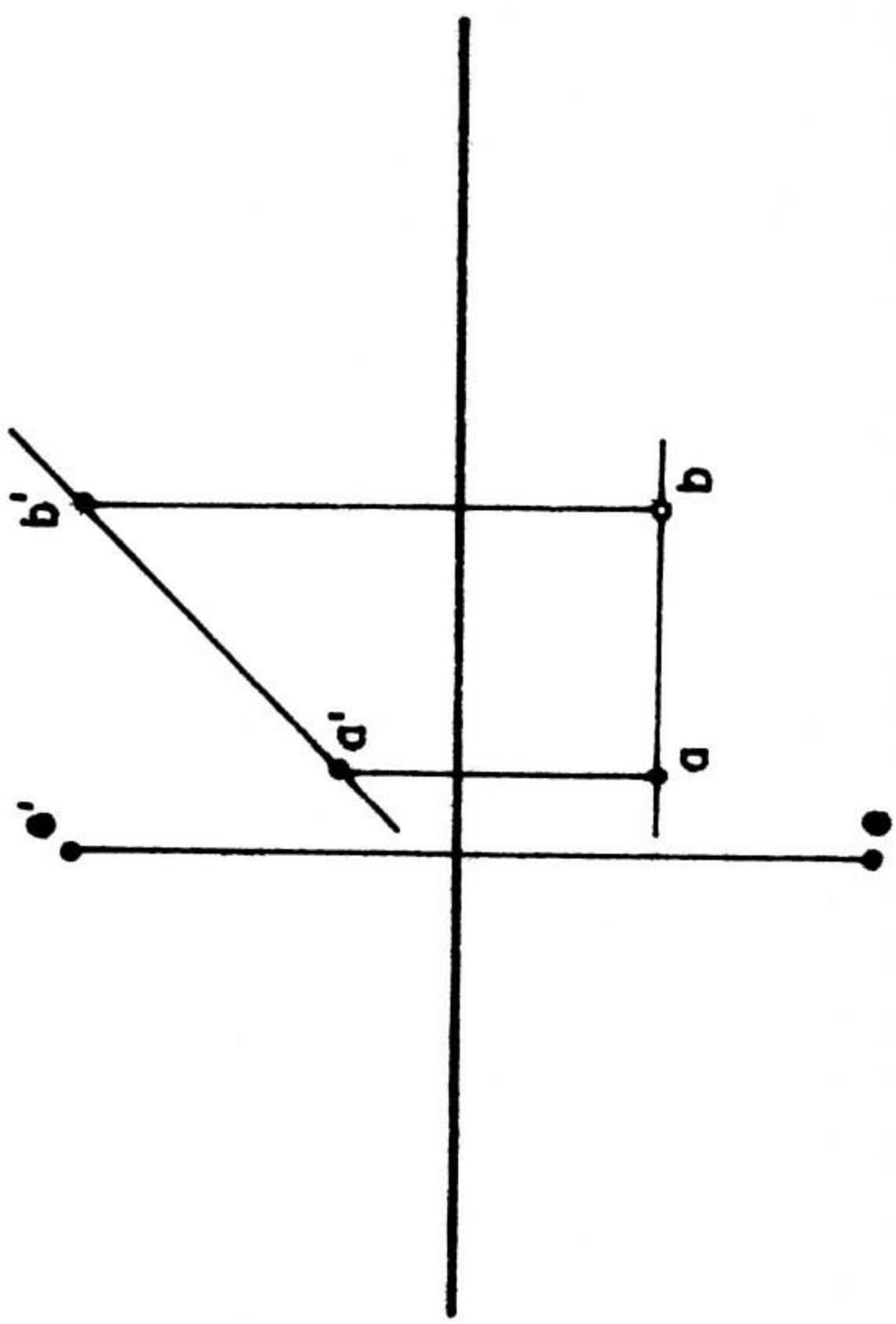

A TRAZAR POR EL PUNTO E, UNA RECTA PERPENDICULAR A AB.

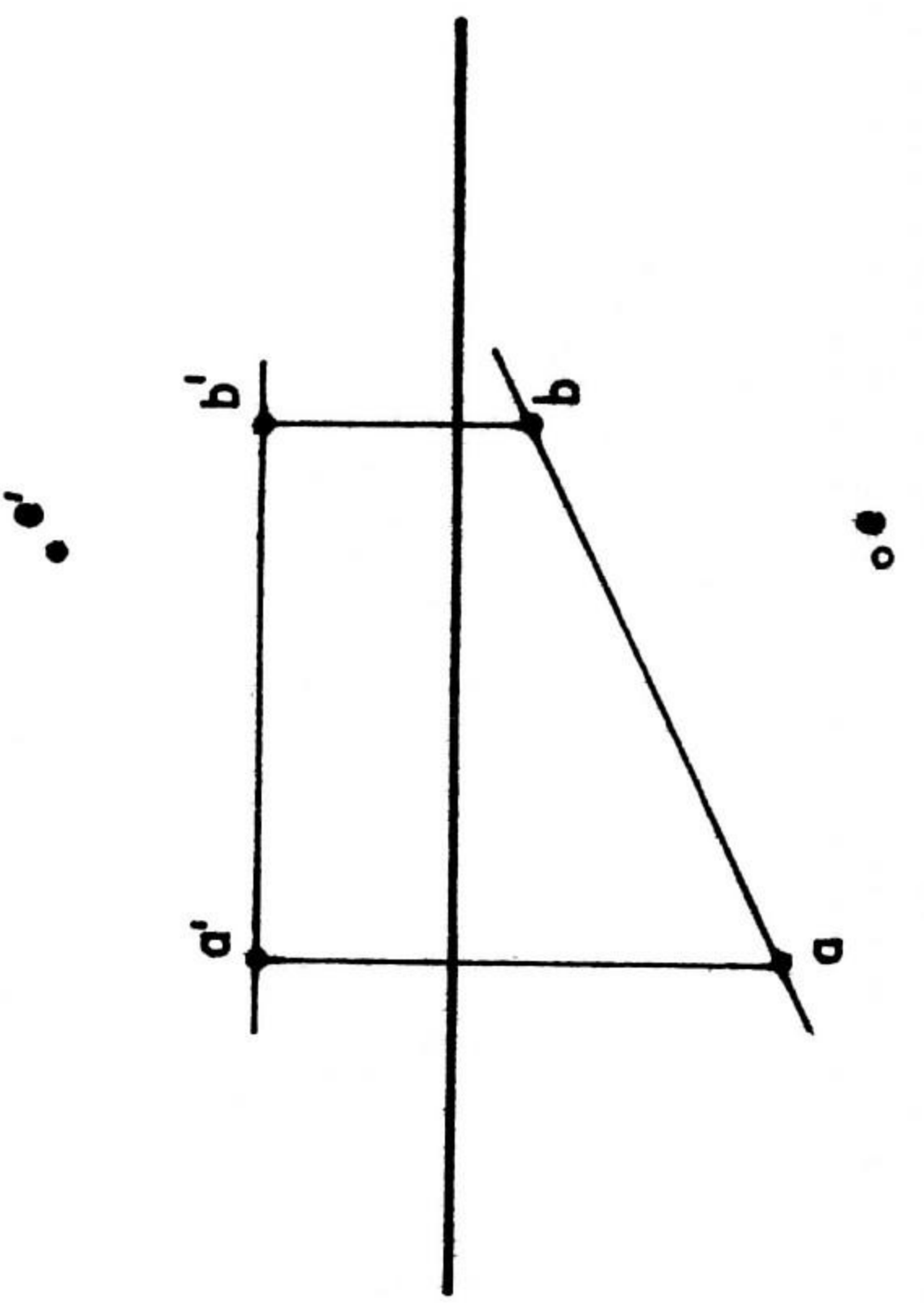

D TRAZAR POR EL PUNTO R SITUADO EN EL PLANO Q DEL TRIANGULO, UNA PERPENDICULAR AL PLANO Q.

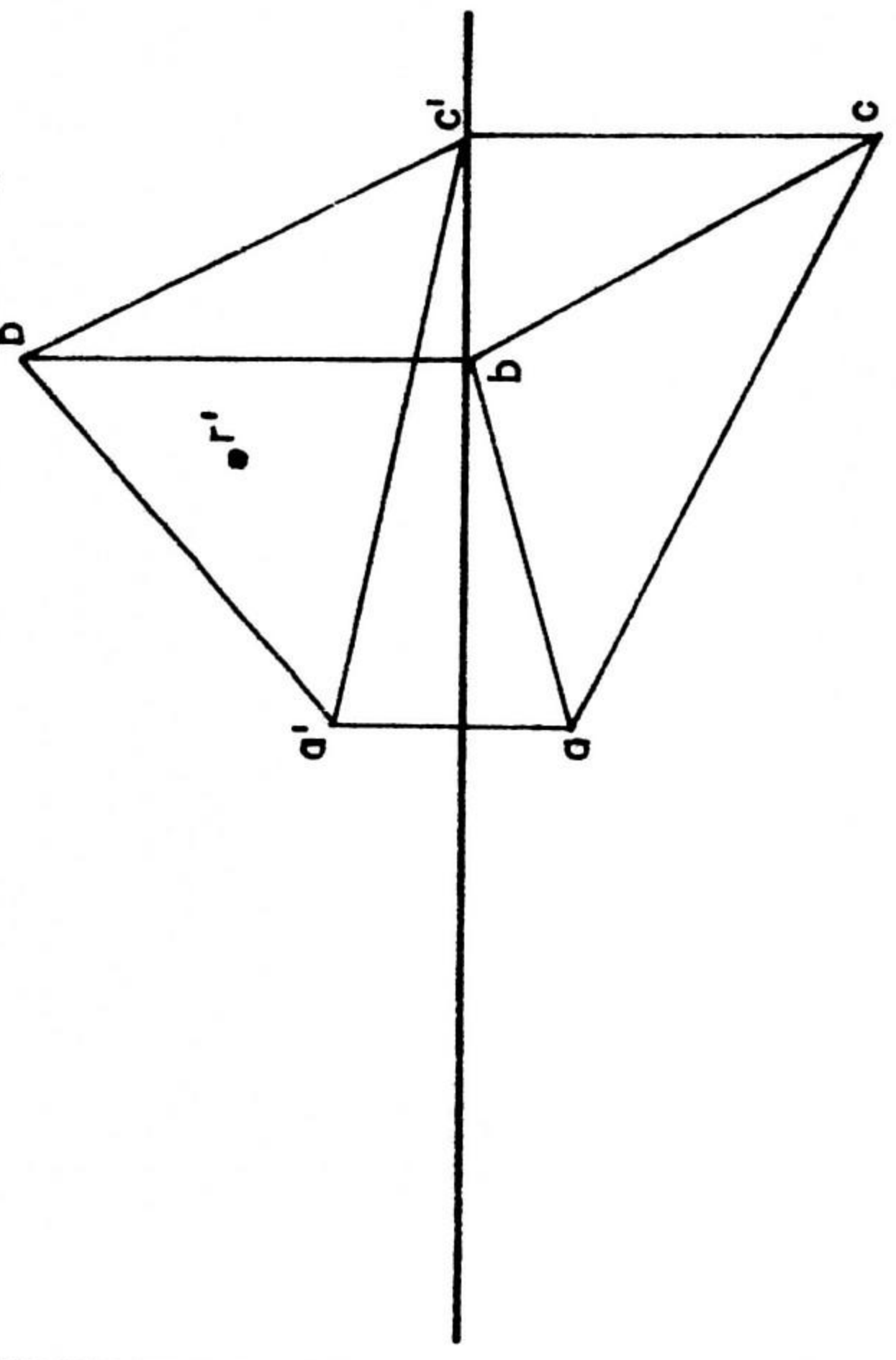

C TRAZAR POR EL PUNTO A SITUADO EN EL PLANO R, UNA RECTA PERPENDICULAR A DICHO PLANO.

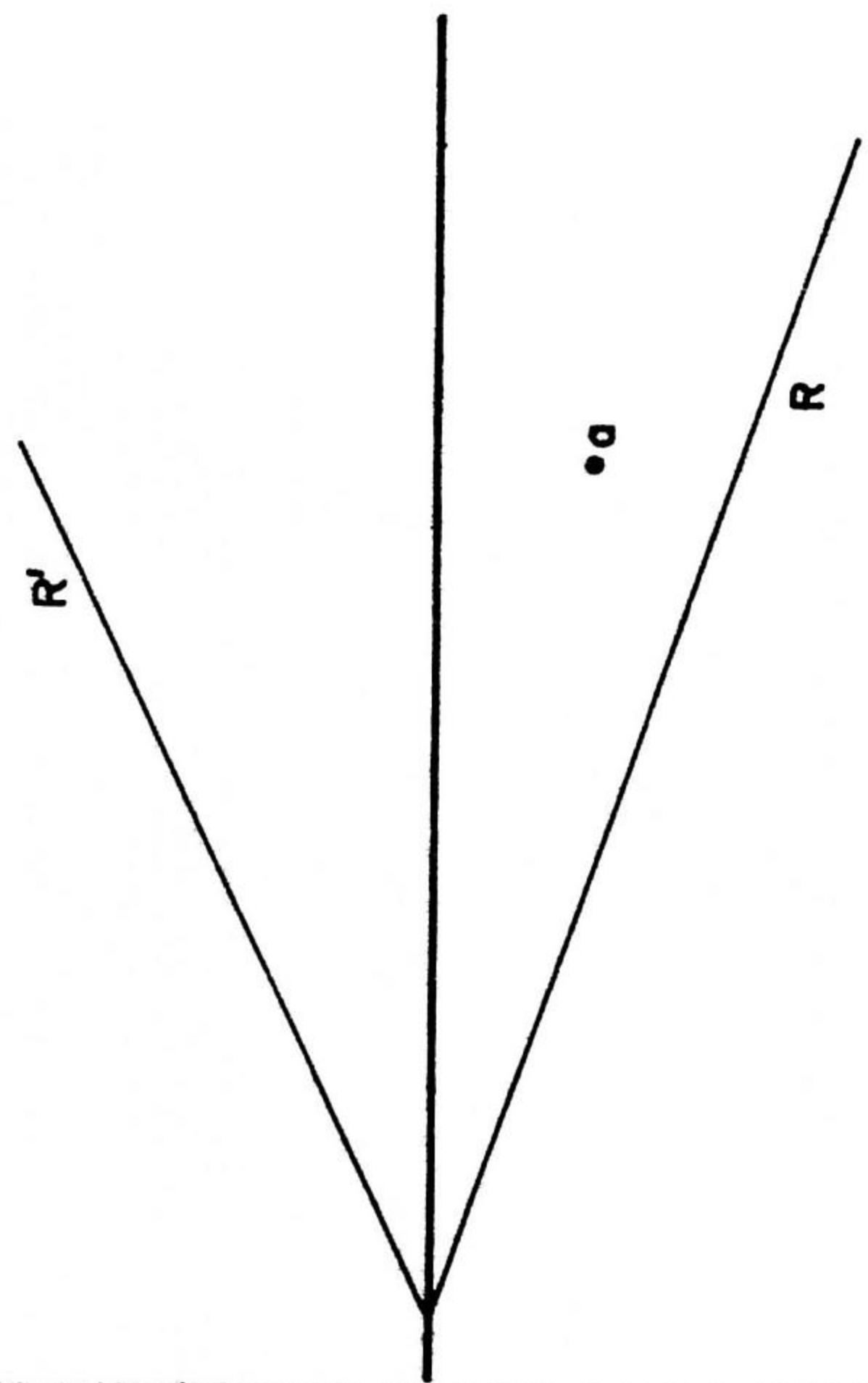

DPTO. DISEÑO BASICO

ISPJAE FACULTAD DE ARQUITECTURA

ASIGNATURA	TEMA		
DOC.	ALUM.		No.
FECHA			EVAL.

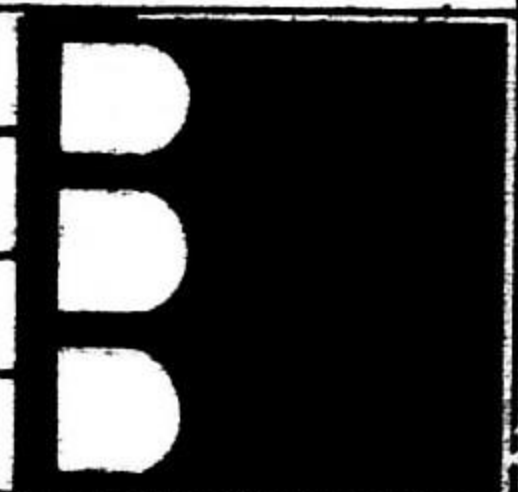

3.6.4 INTERSECCIONES DE PLANOS

B DETERMINAR LA INTERSECCION DE LOS DOS PLANOS VERTICALES Q Y R

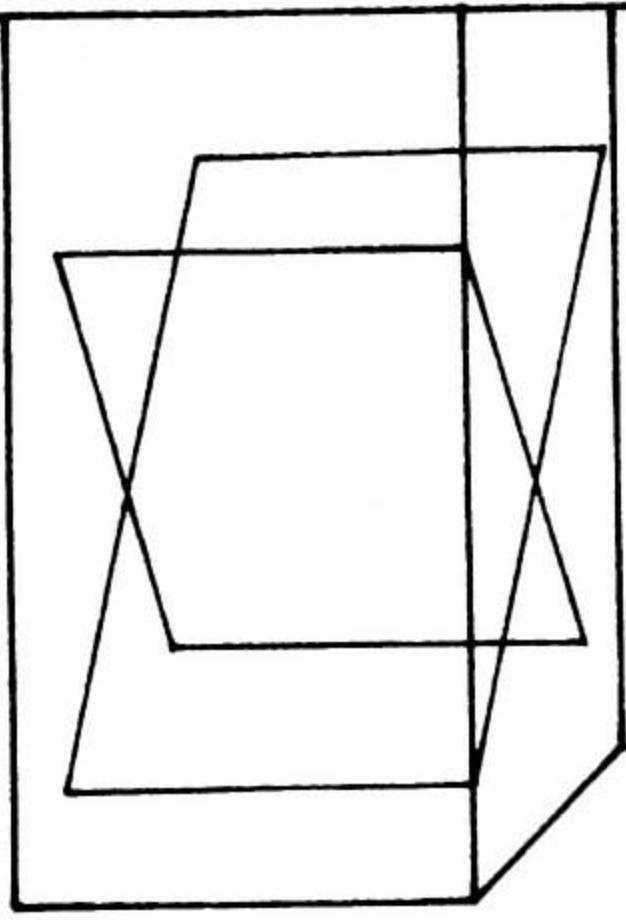
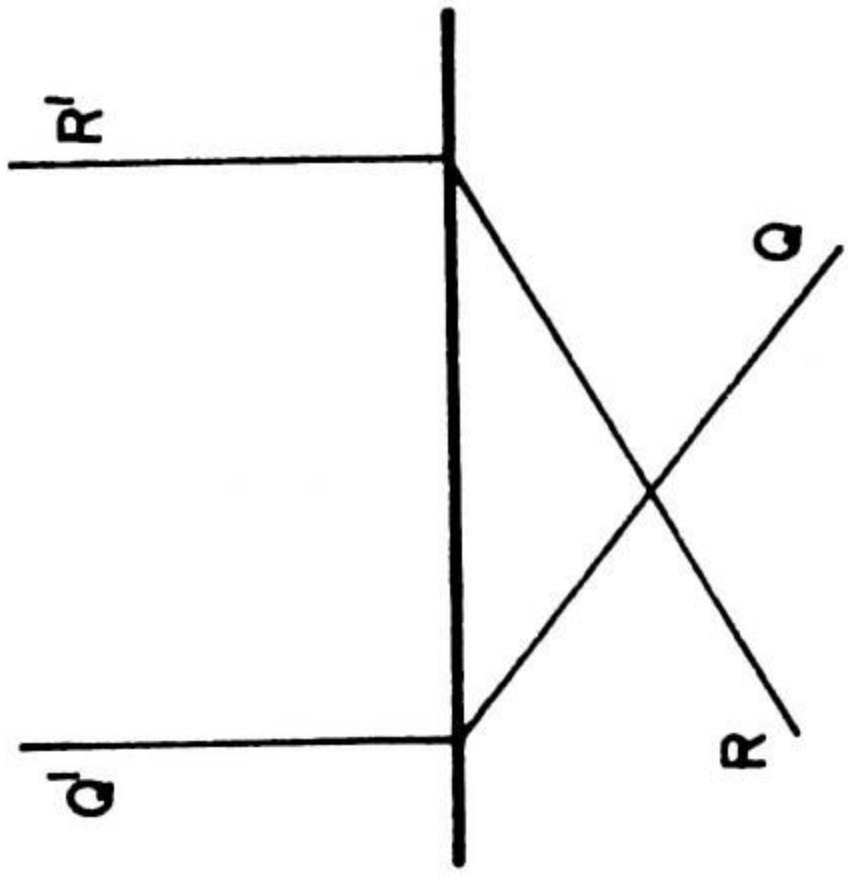

D DETERMINAR LA INTERSECCION DE LOS PLANOS INCLINADOS Q Y R

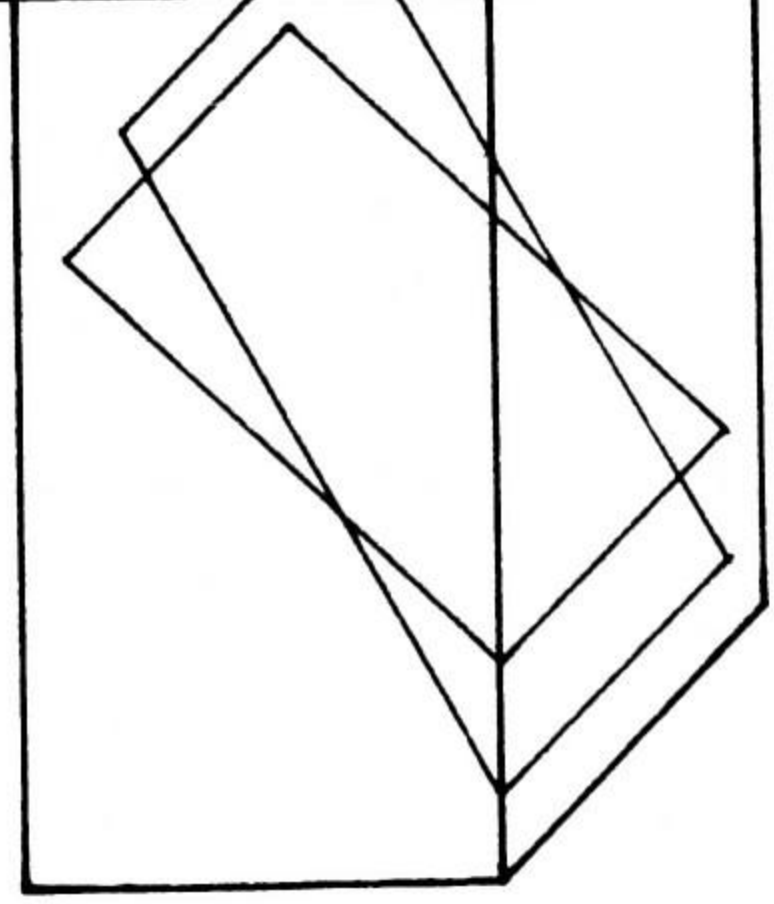
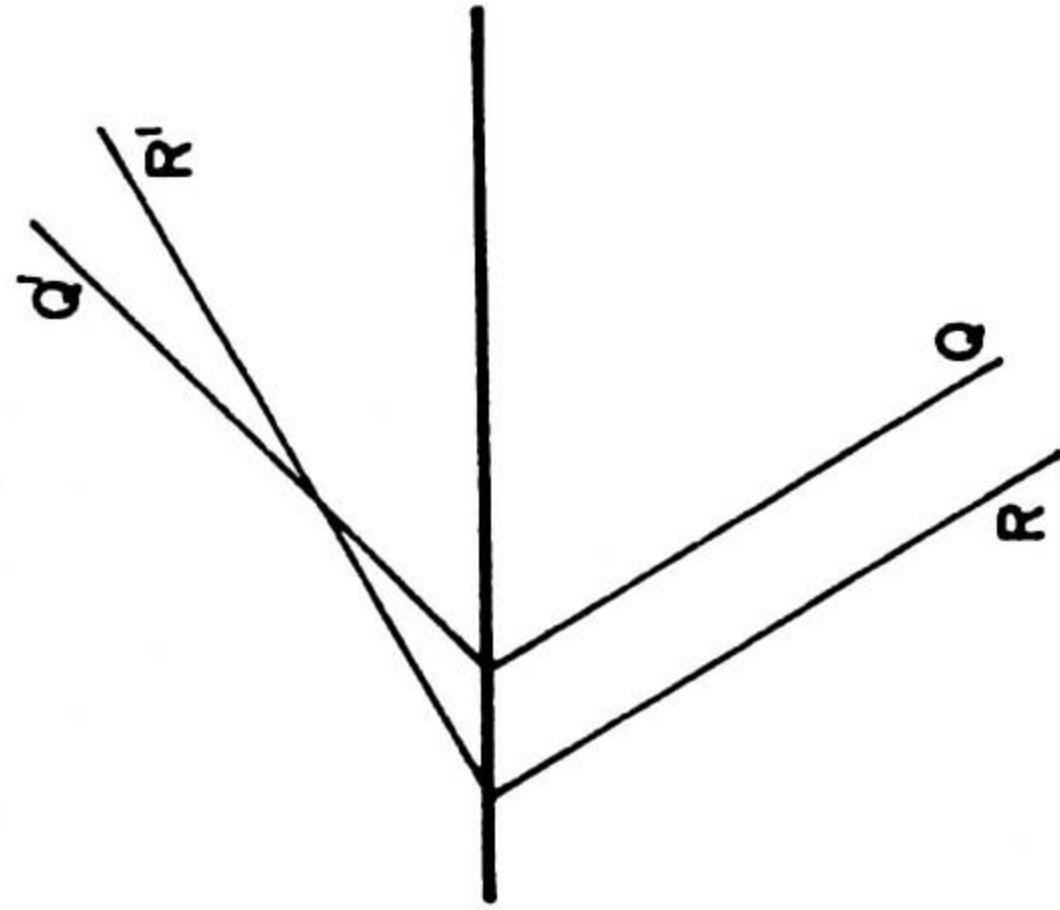

A DETERMINAR LA INTERSECCION DEL PLANO HORIZONTAL R CON EL INCLINADO Q.

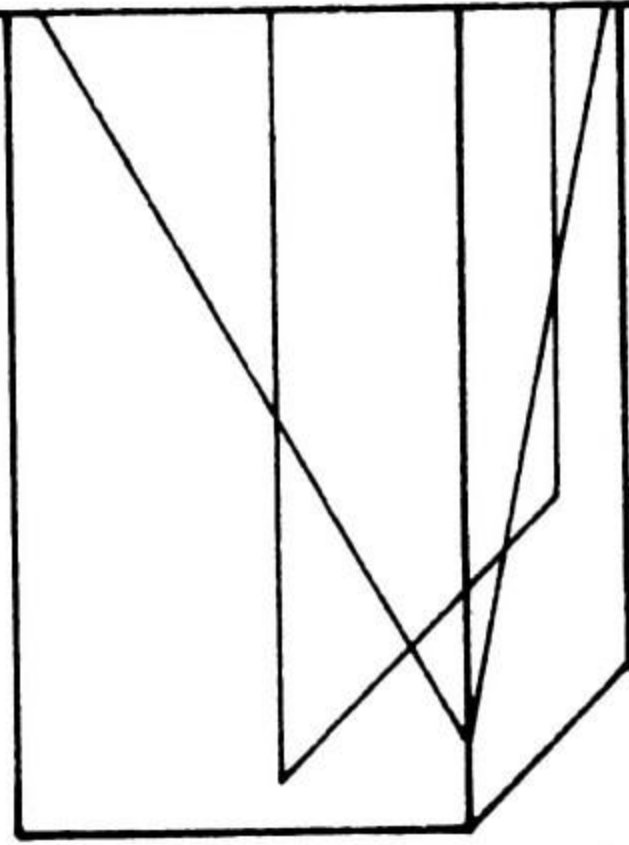
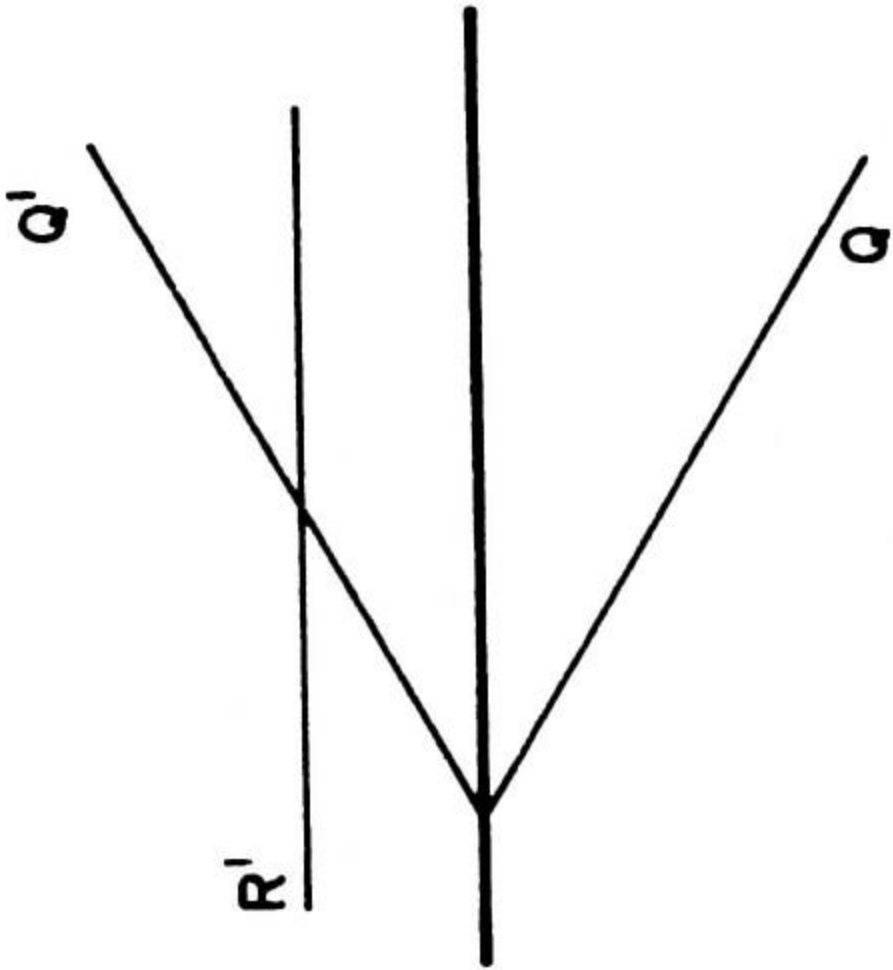

C DETERMINAR LA INTERSECCION DEL PLANO INCLINADO Q CON EL VERTICAL R

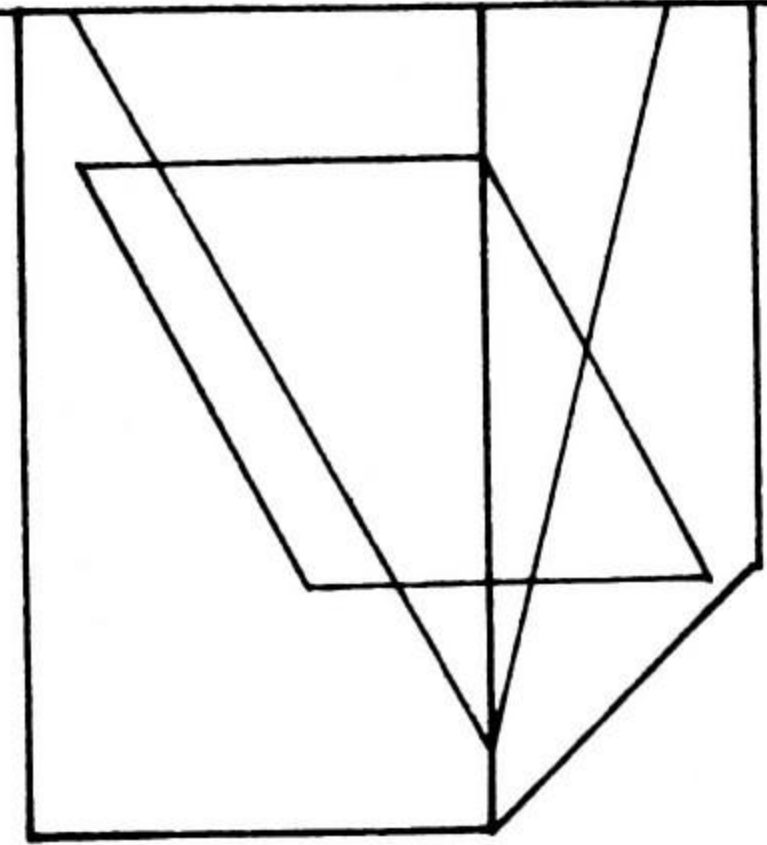
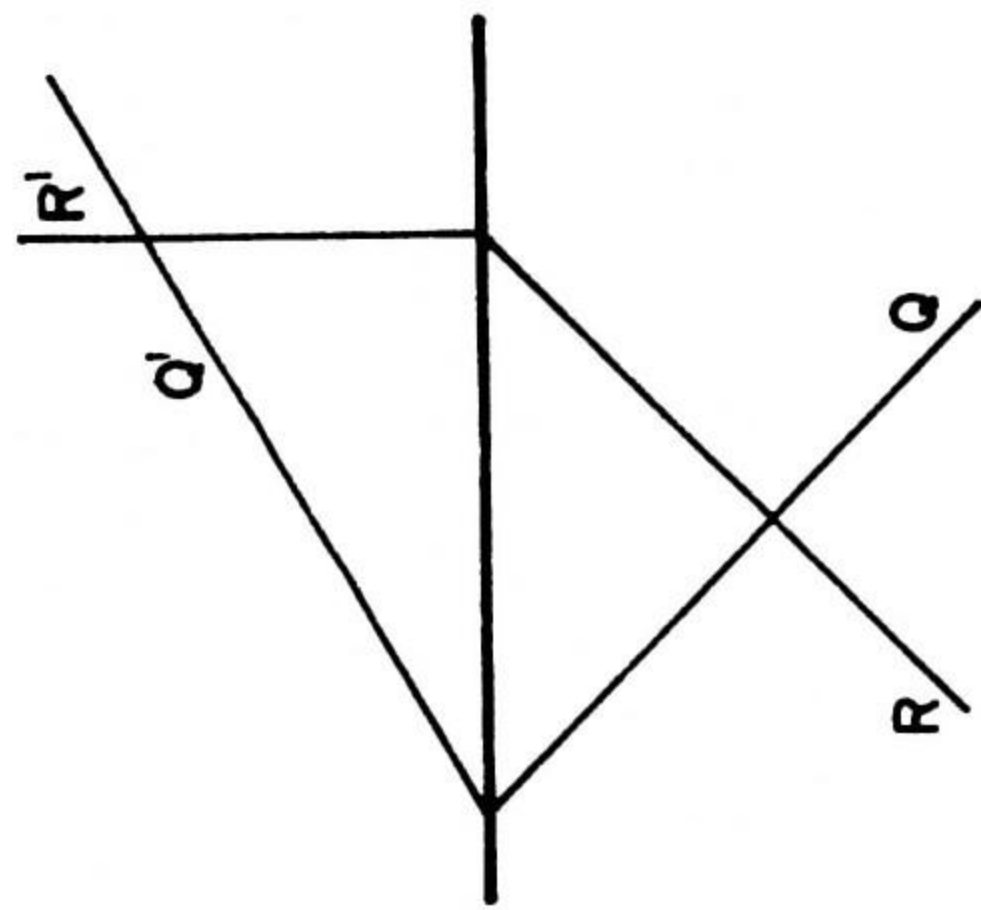

DPTO. DISEÑO BASICO

ISPJAE FACULTAD DE ARQUITECTURA

ASIGNATURA

TEMA

DOC.

ALUM.

No.

GRUPO

FECHA

EVAL.

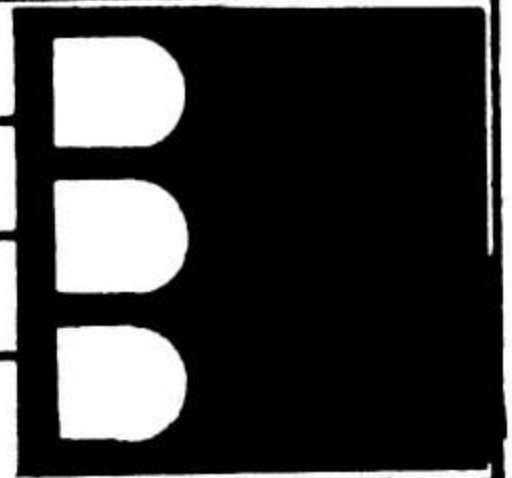

3.6.5 INTERSECCIONES - RECTA CON FIGURA PLANA - VISIBILIDAD

<p>A</p>	<p>B</p>	<p>C</p>
<p>D</p>	<p>E</p>	<p>F</p>
<p>G</p>	<p>H</p>	<p>I</p>
<p>J</p>	<p>K</p>	<p>L</p>

DPTO. DISEÑO BASICO		ISPJAE		FACULTAD DE ARQUITECTURA	
ASIGNATURA	TEMA				
DOC.	ALUM.			No.	GRPO.
FECHA				EVAL.	

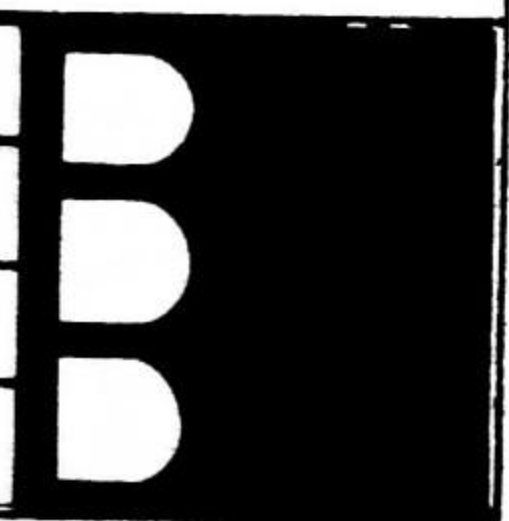

3.6.6 INTERSECCIONES - DOS FIGURAS PLANAS - VISIBILIDAD

A

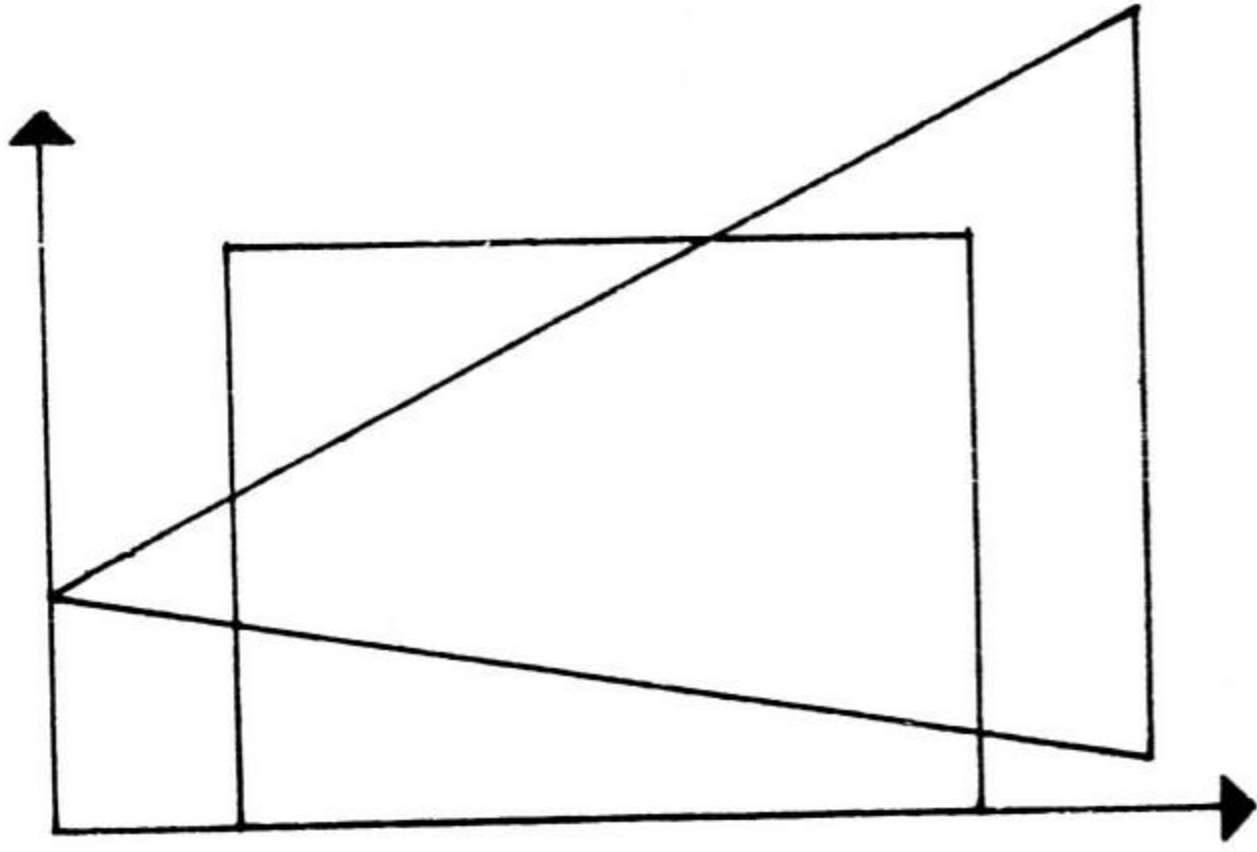
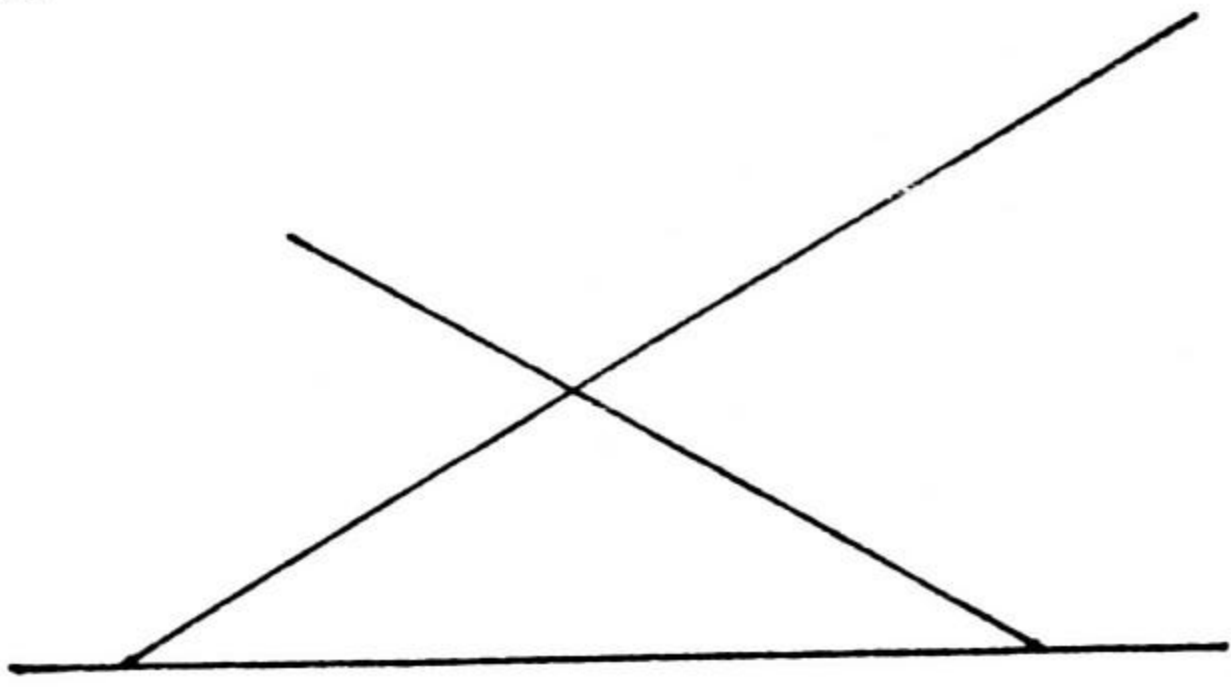

B

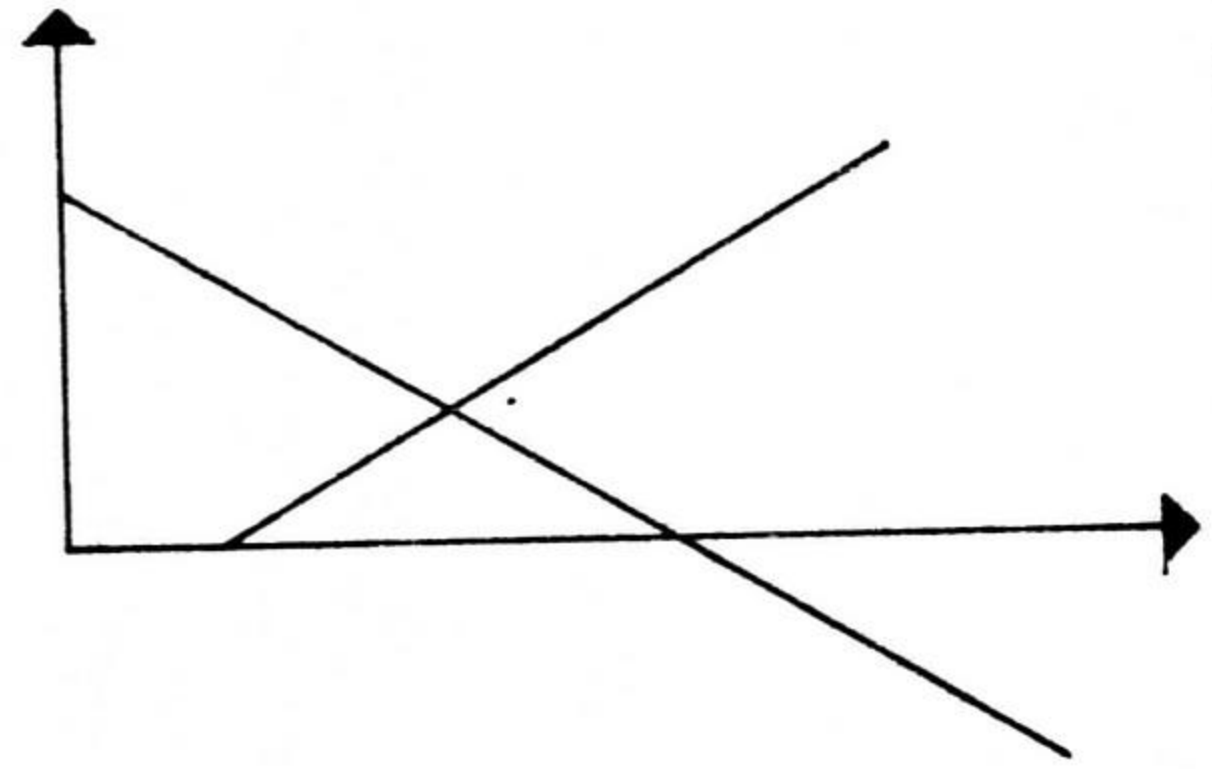
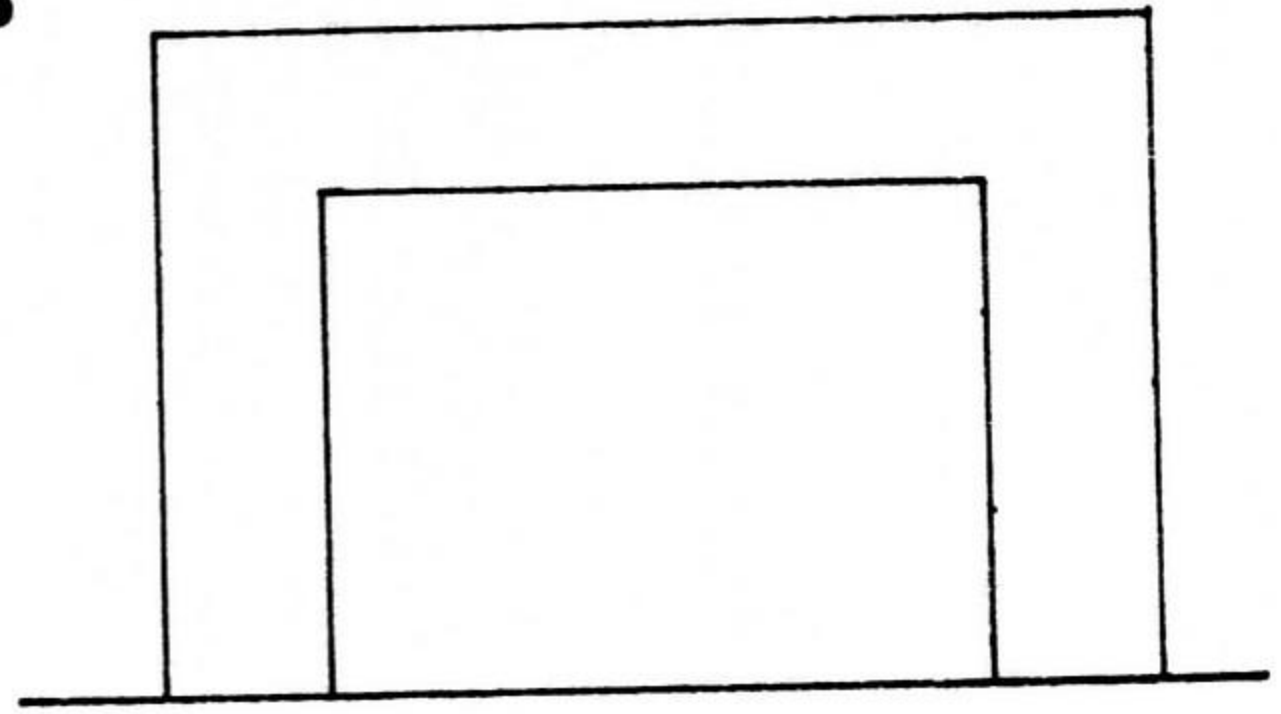

C

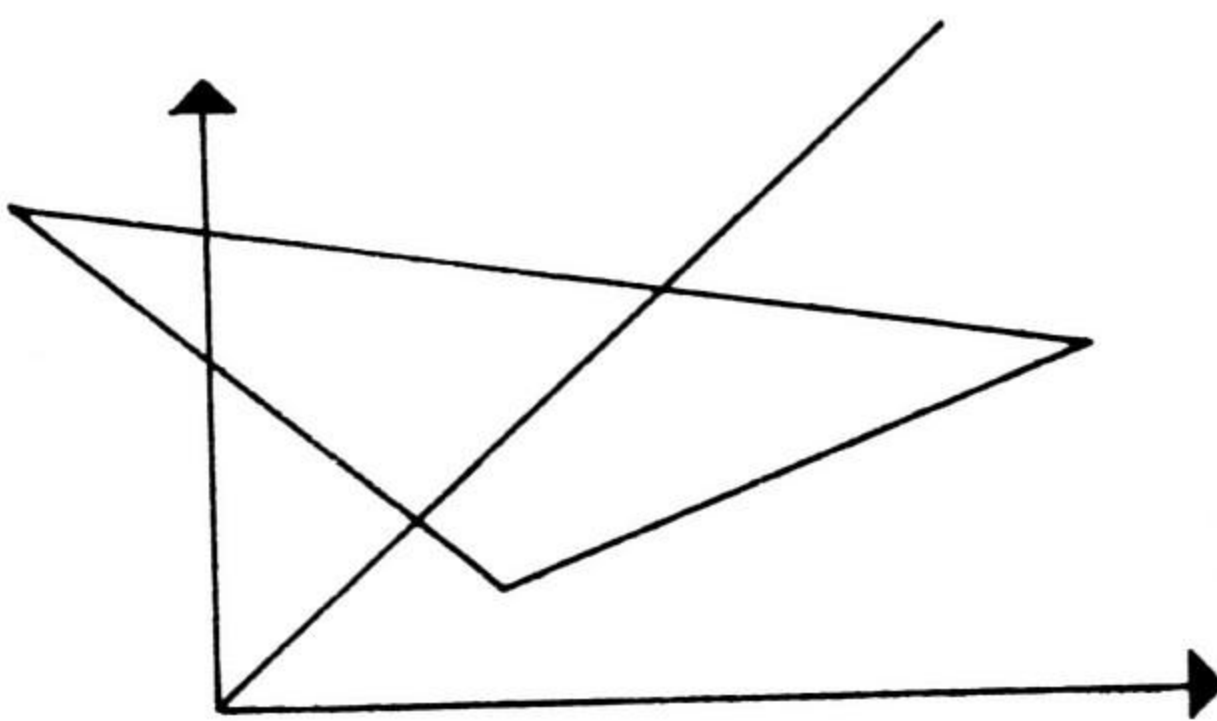
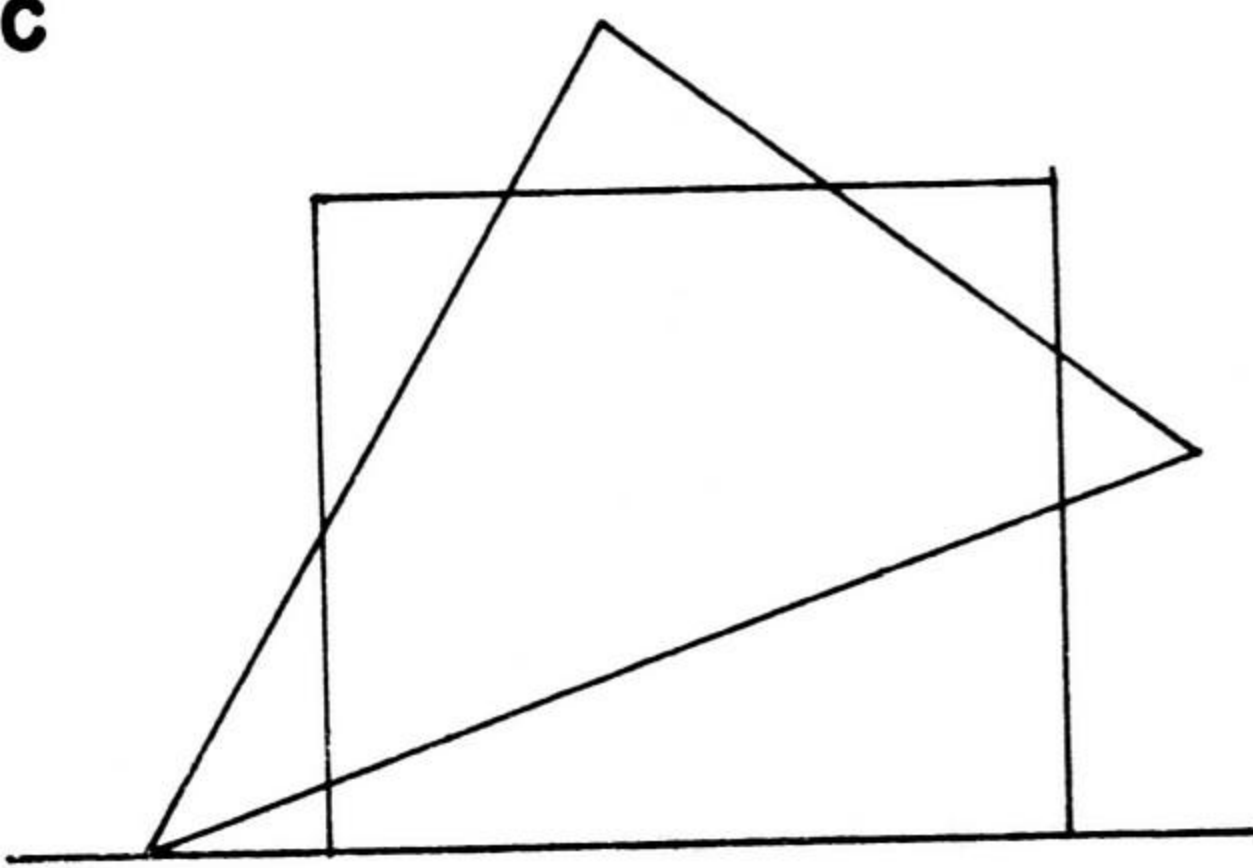

D

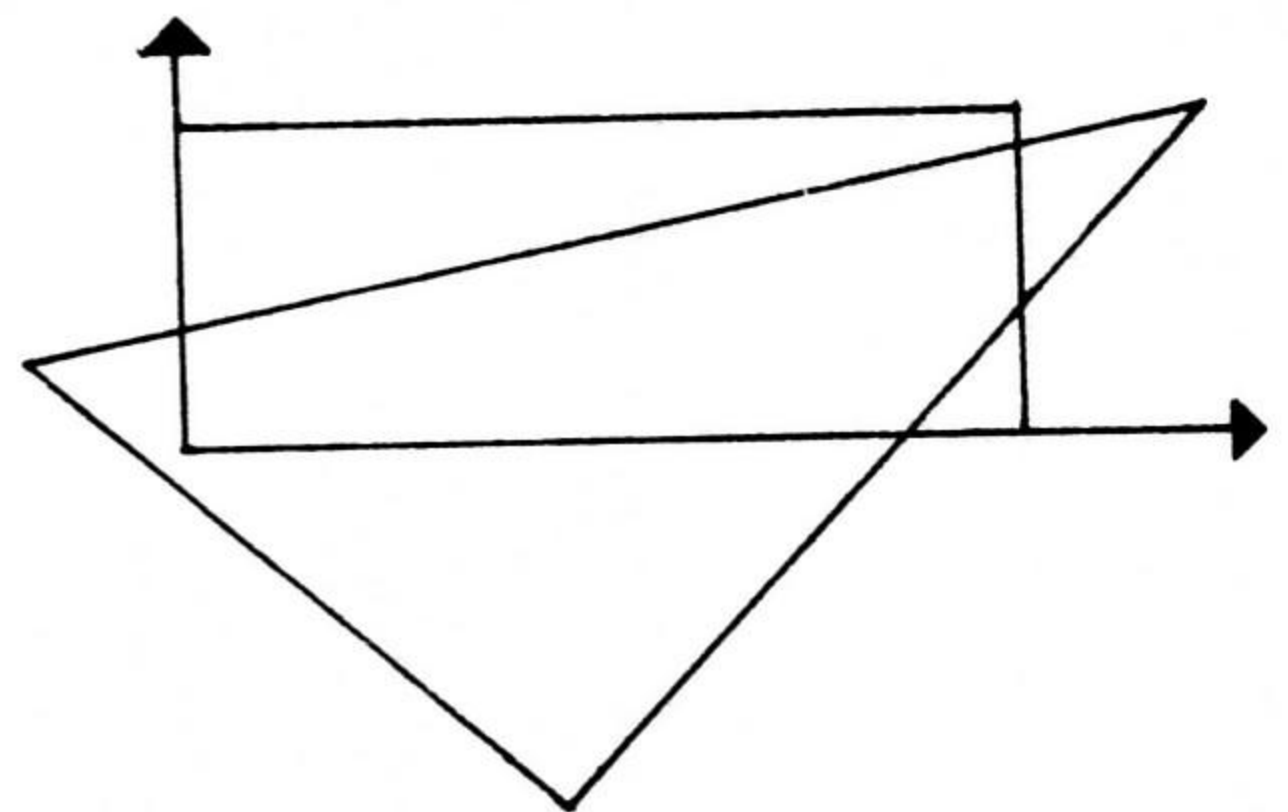
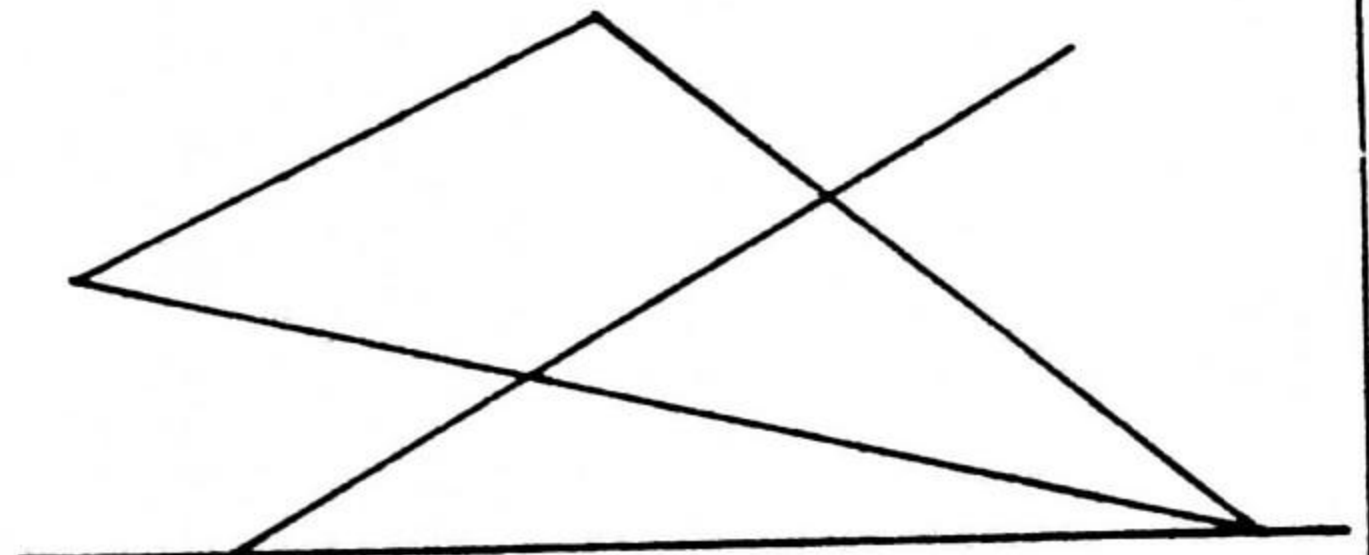

DPTO. DISEÑO BASICO

ISPJAE FACULTAD DE ARQUITECTURA

ASIGNATURA	TEMA		
DOC.	ALUM.	No.	GPO.
FECHA		EVAL.	

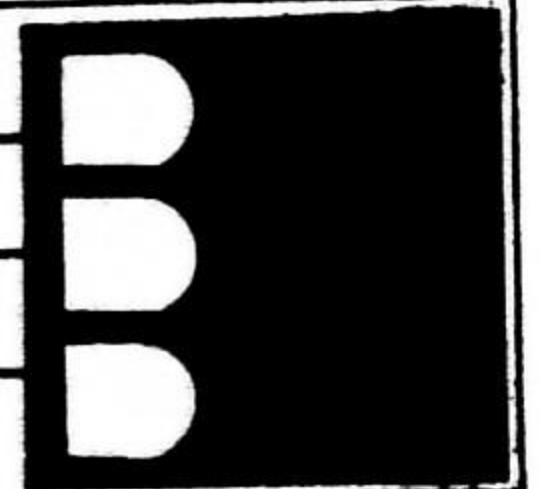

3.6.6 INTERSECCIONES - DOS FIGURAS PLANAS - VISIBILIDAD

E

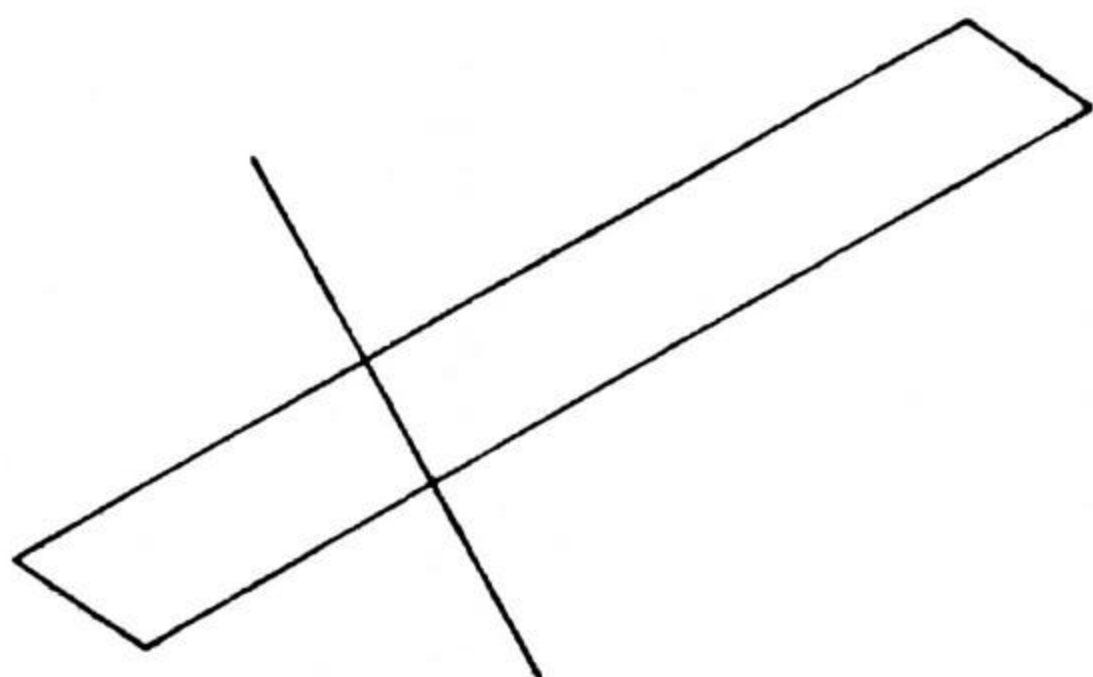
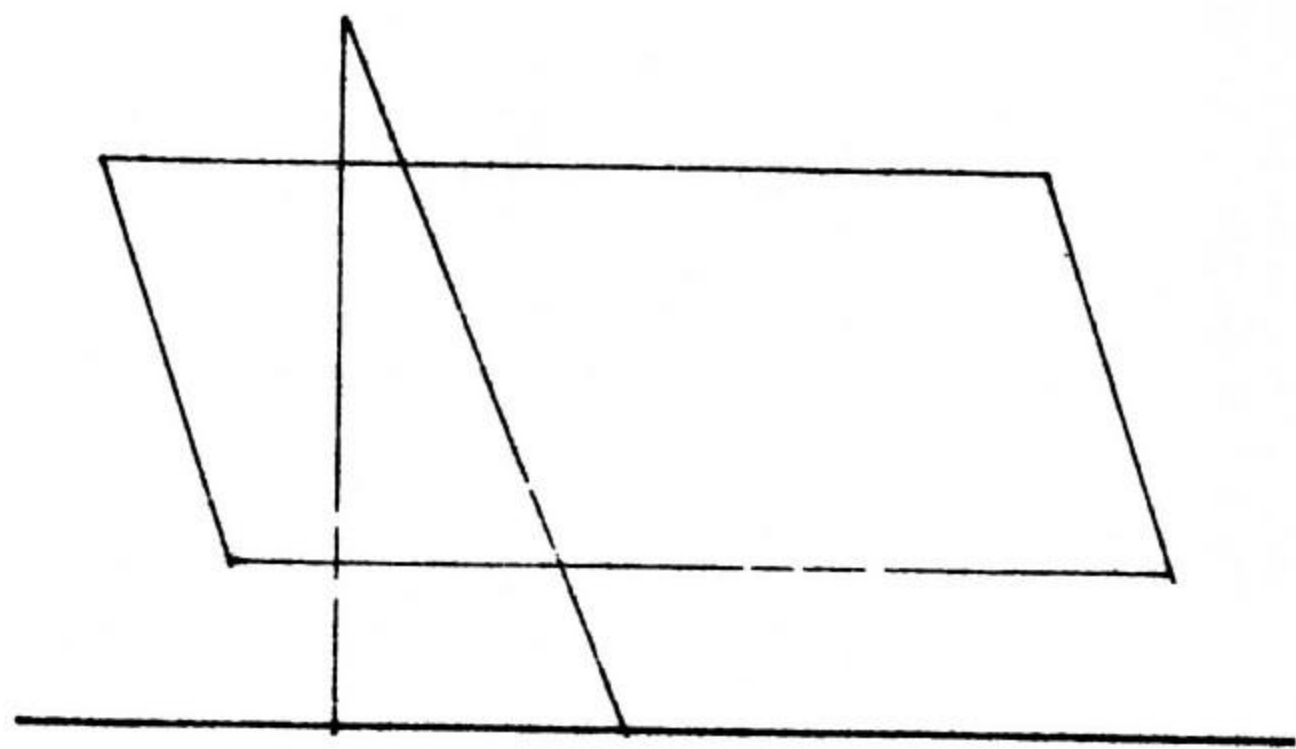

F

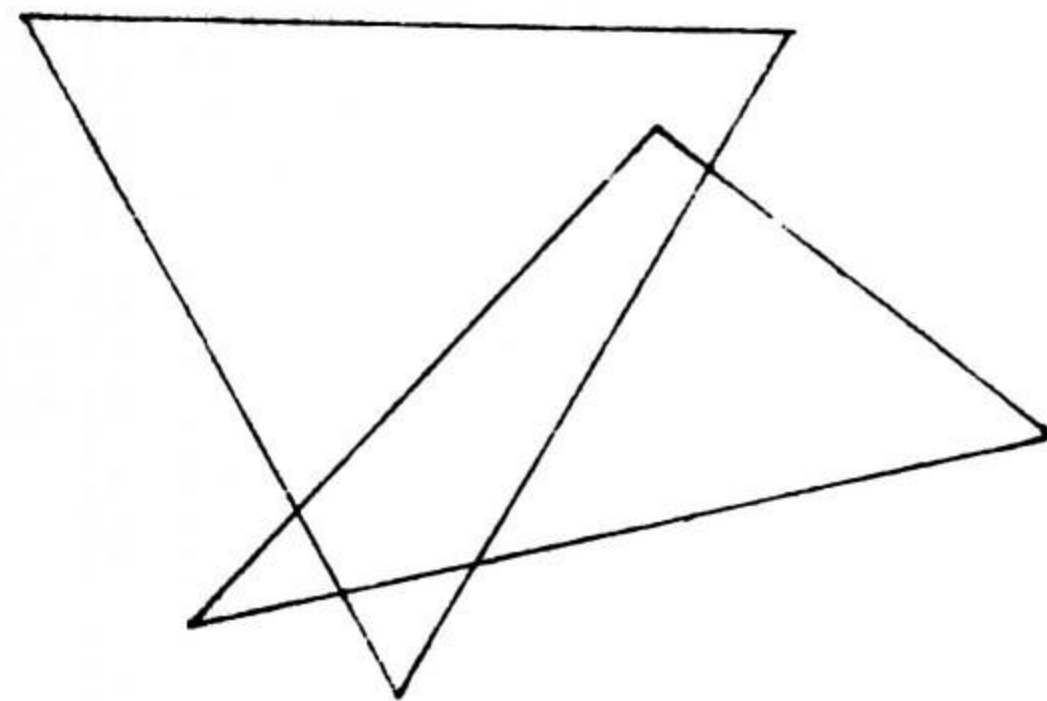
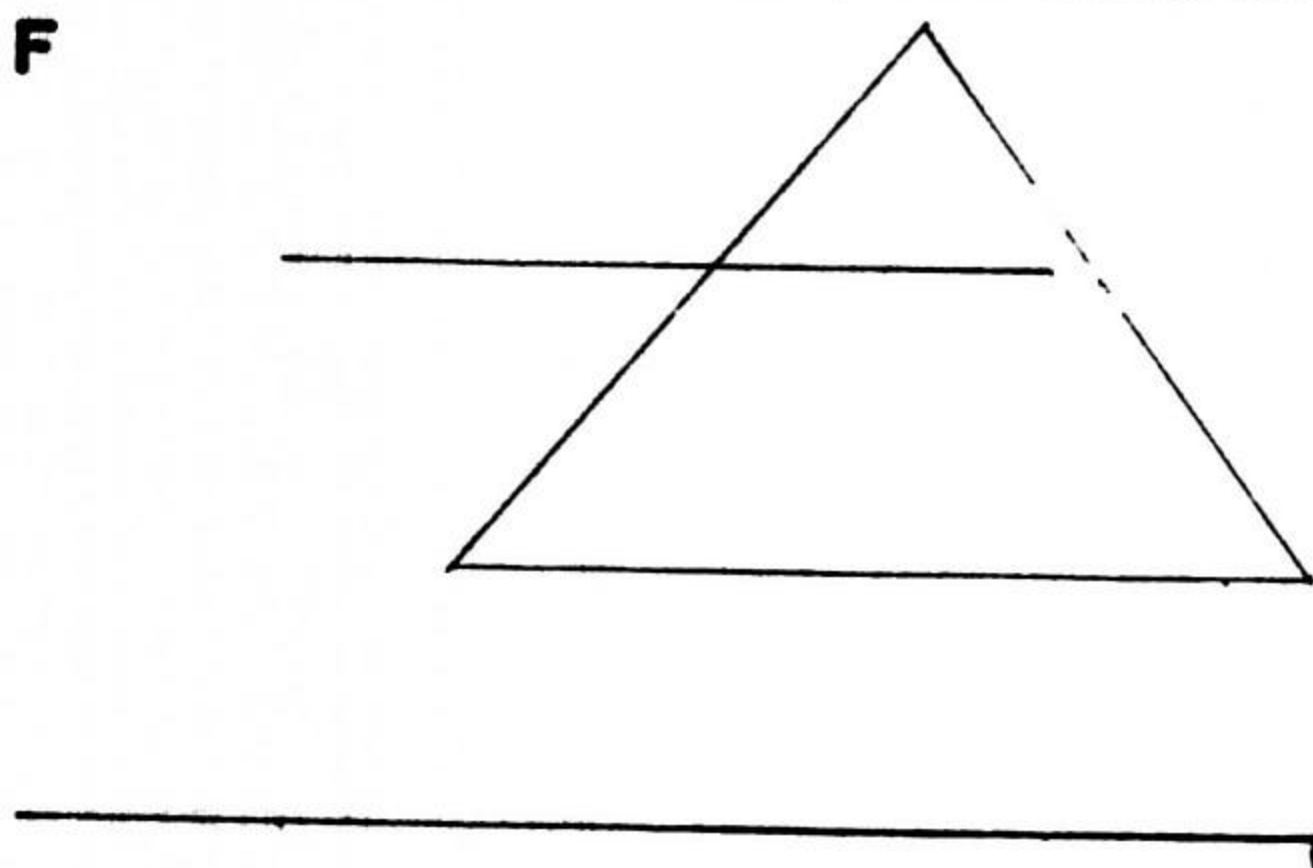

G

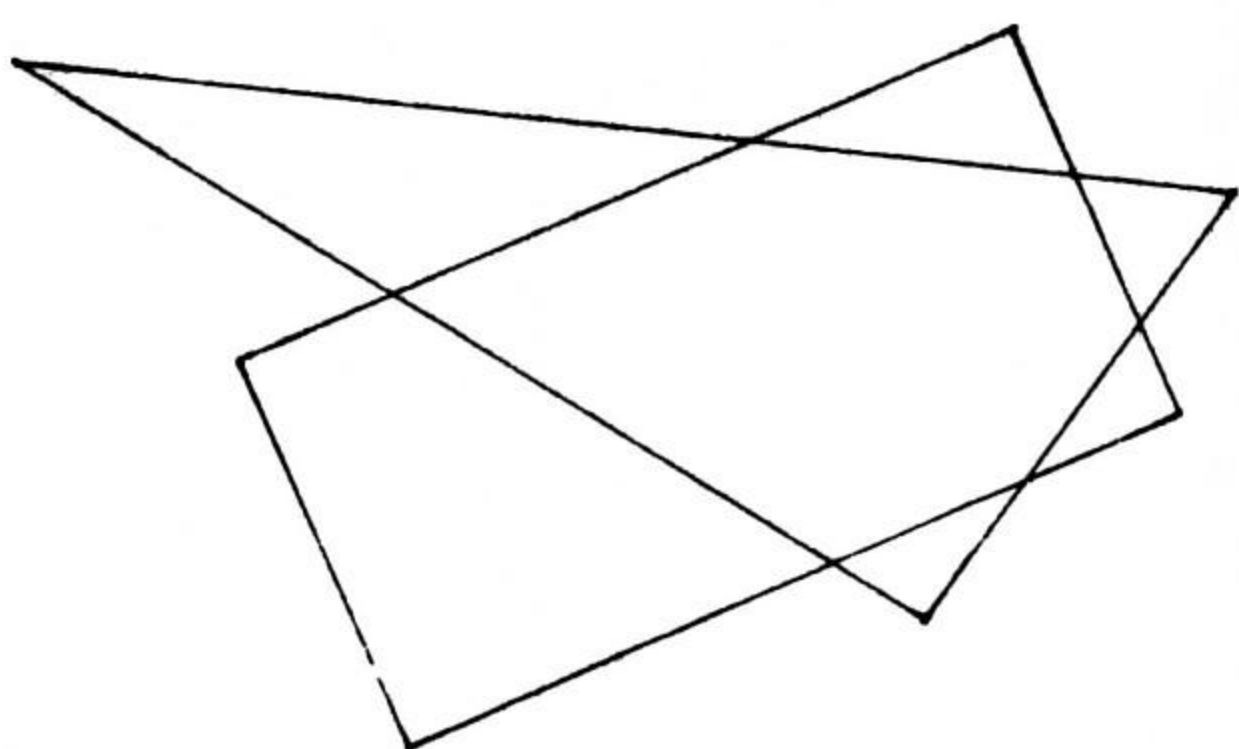
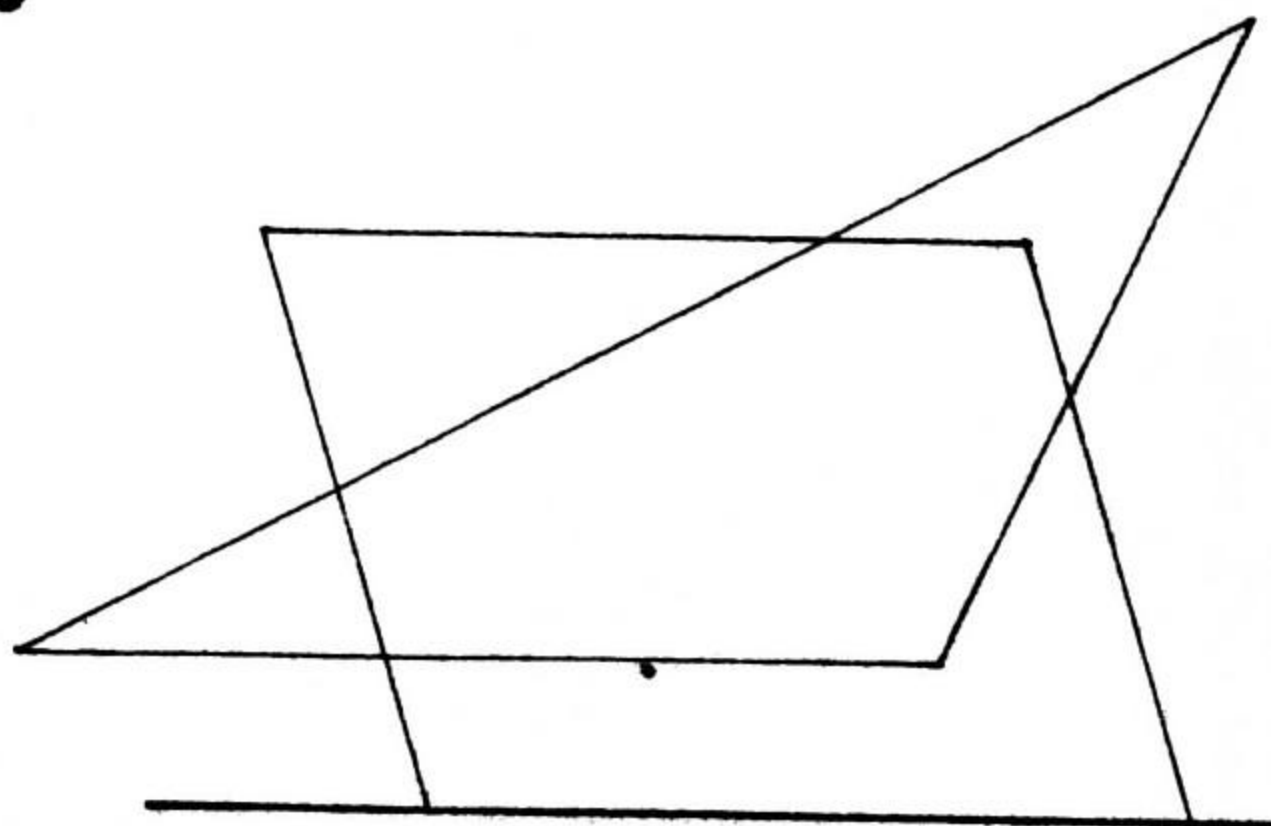

H

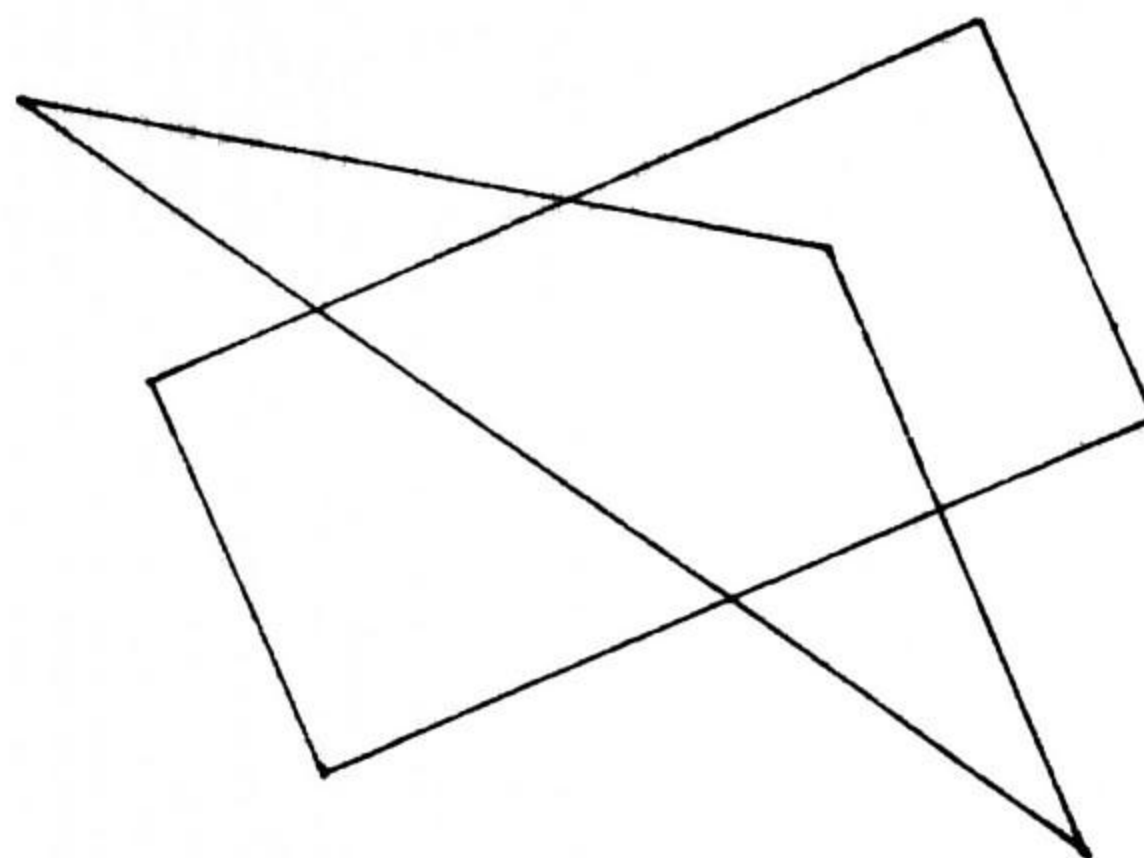
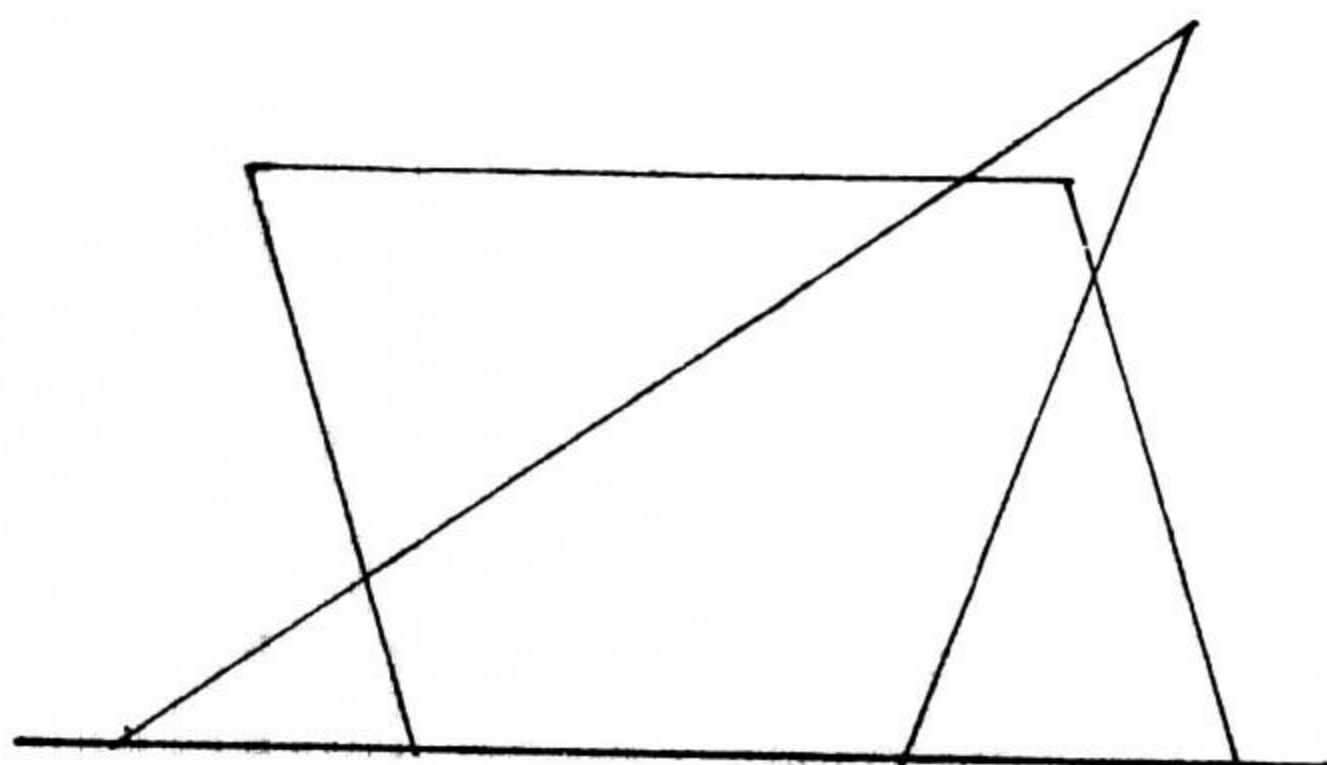

DPTO. DISEÑO BASICO

ISPJAE FACULTAD DE ARQUITECTURA

ASIGNATURA	TEMA			D B D
DOC.	ALUM.	No.	OPC.	
FECHA		EVAL.		

4.2 CAMBIO DE PLANOS.

B DETERMINAR LA FORMA REAL DEL TRIANGULO

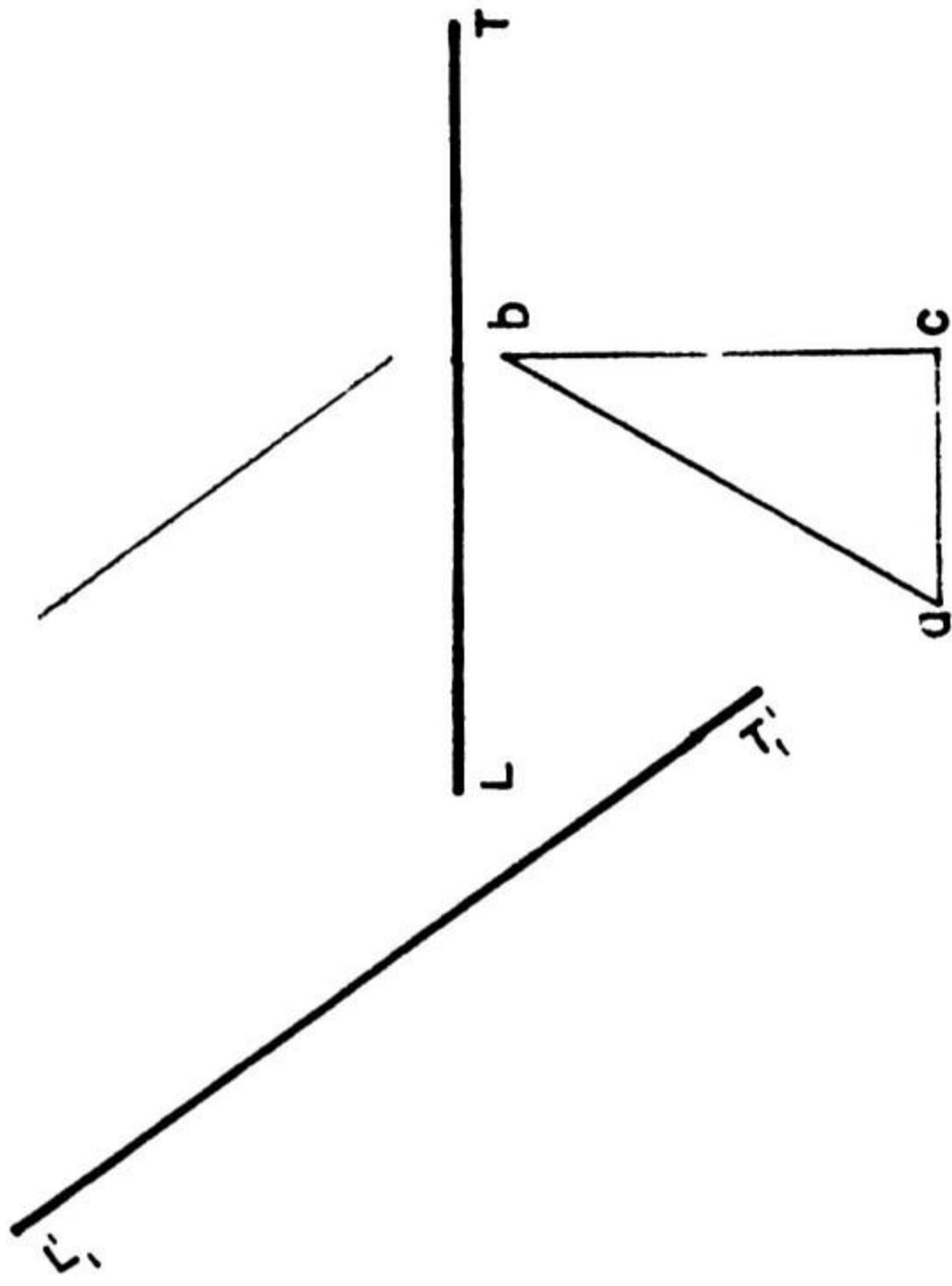

D HACER QUE EL TRIANGULO SE PERCIBA DE CANTO EN VISTA DE FRENTE

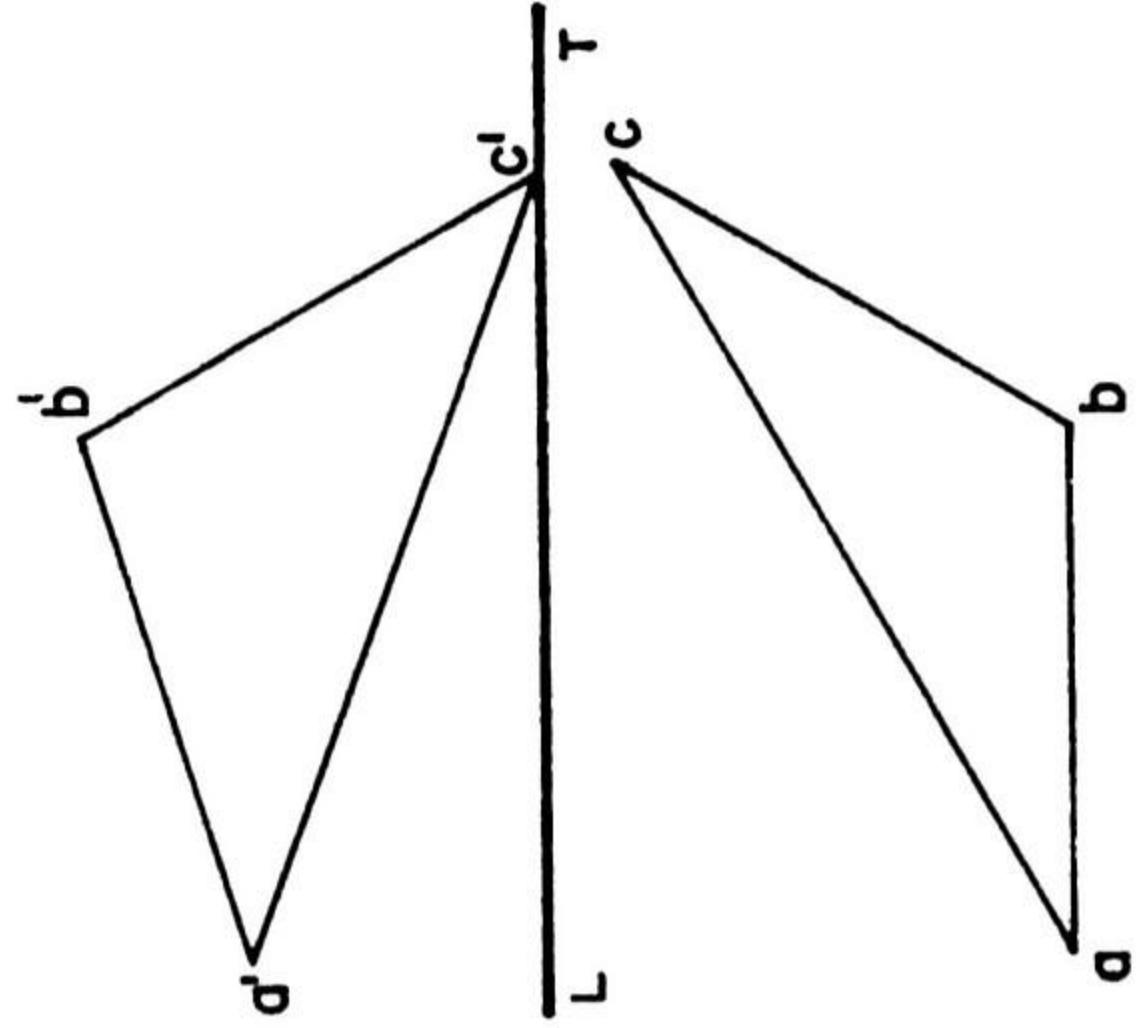

A CONSTRUIR UNA VISTA AUXILIAR DEL CUADRADO

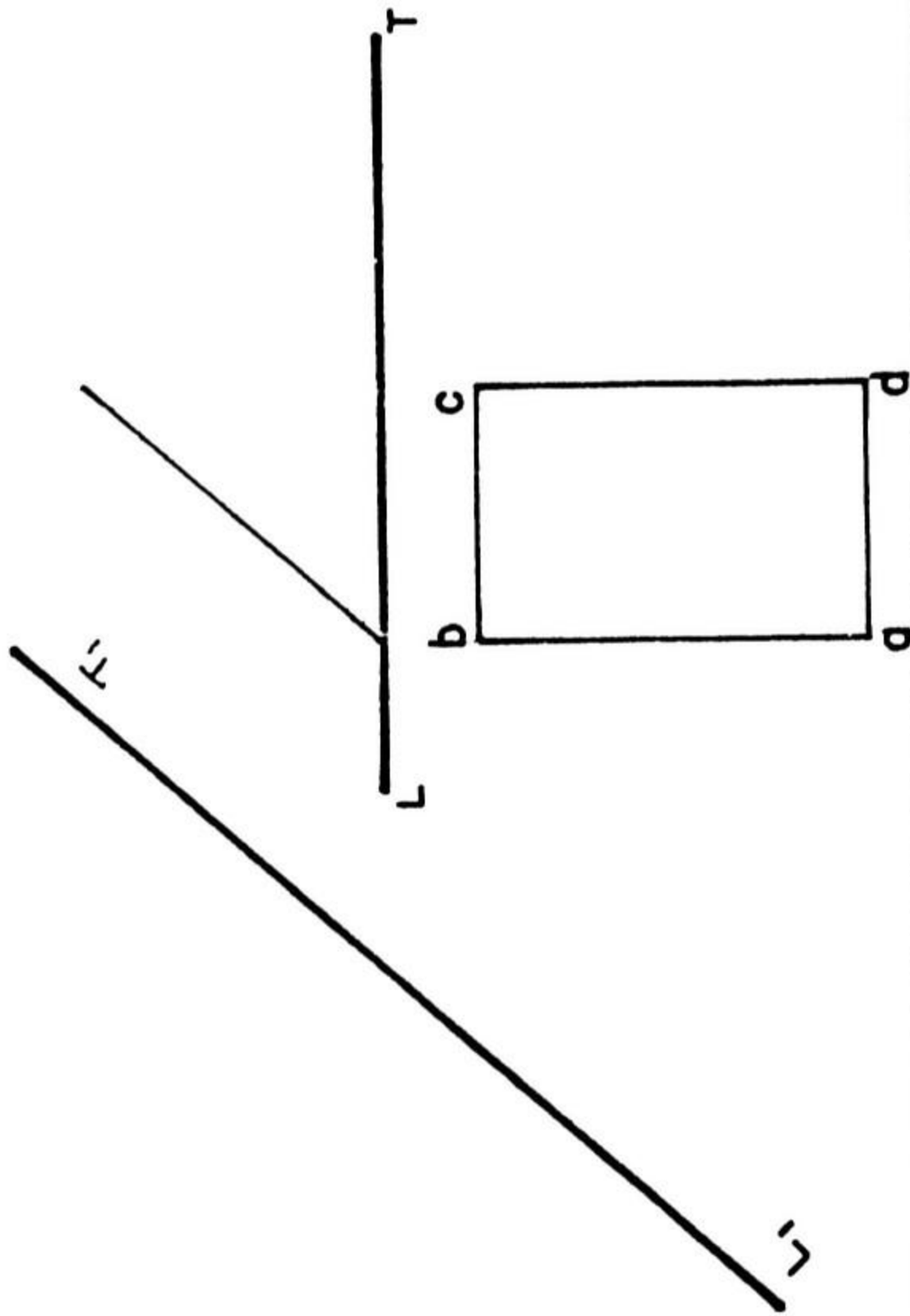

C HACER QUE LA RECTA SE PERCIBA DE PUNTA EN VISTA DE FRENTE.

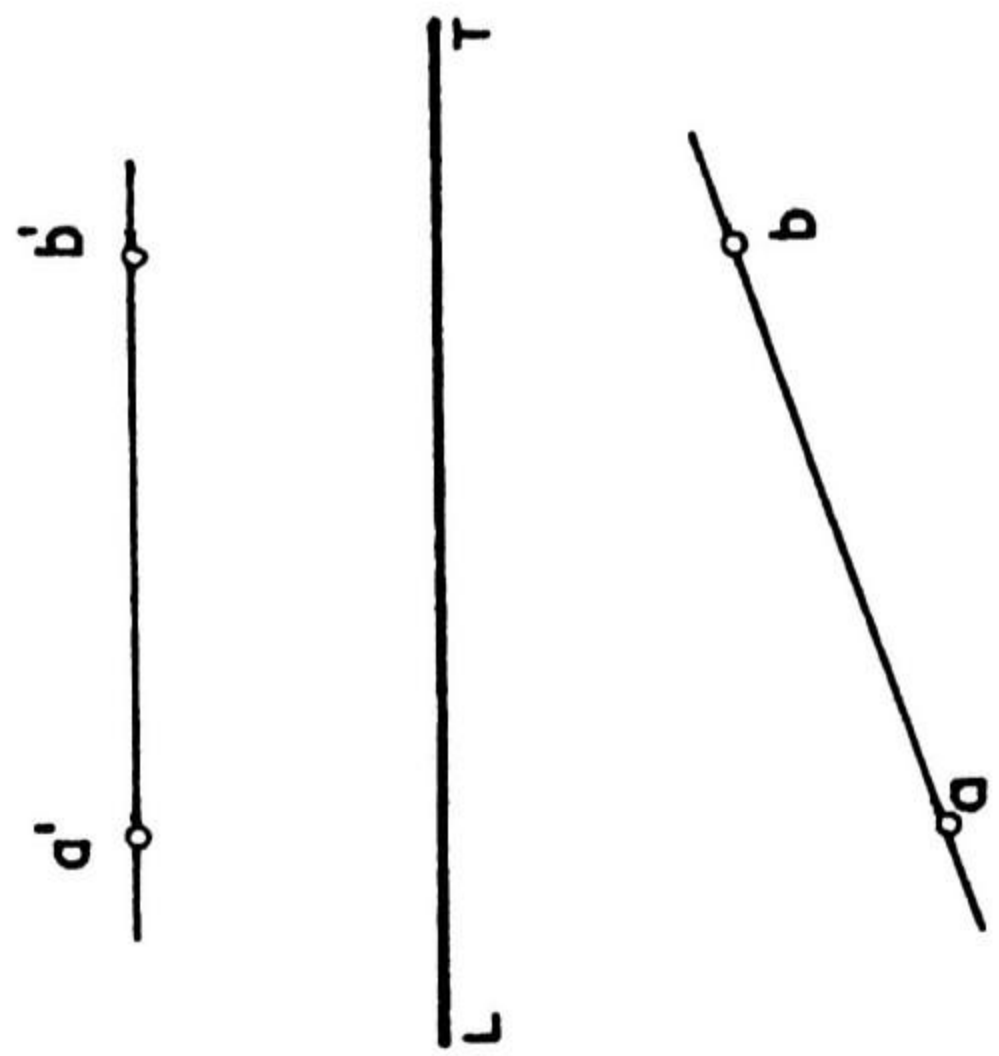

DPTO. DISEÑO BASICO

ISPJAF FACULTAD DE ARQUITECTURA

ASIGNATURA	TEMA				
DOC.	ALUM.			No.	GRUPO.
FECHA				EVAL.	

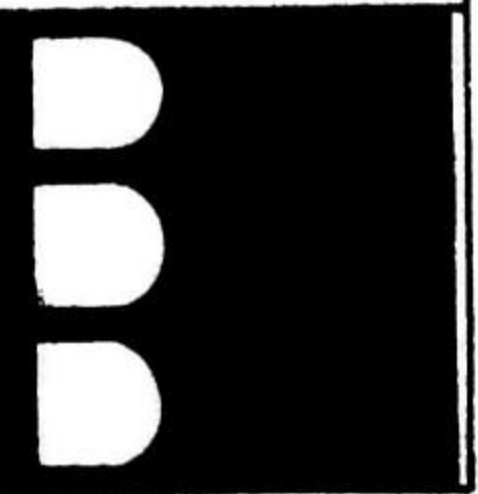

4.2 DETERMINAR LA FORMA REAL DEL TRIANGULO ABC POR EL METODO DE CAMBIO DE PLANOS.

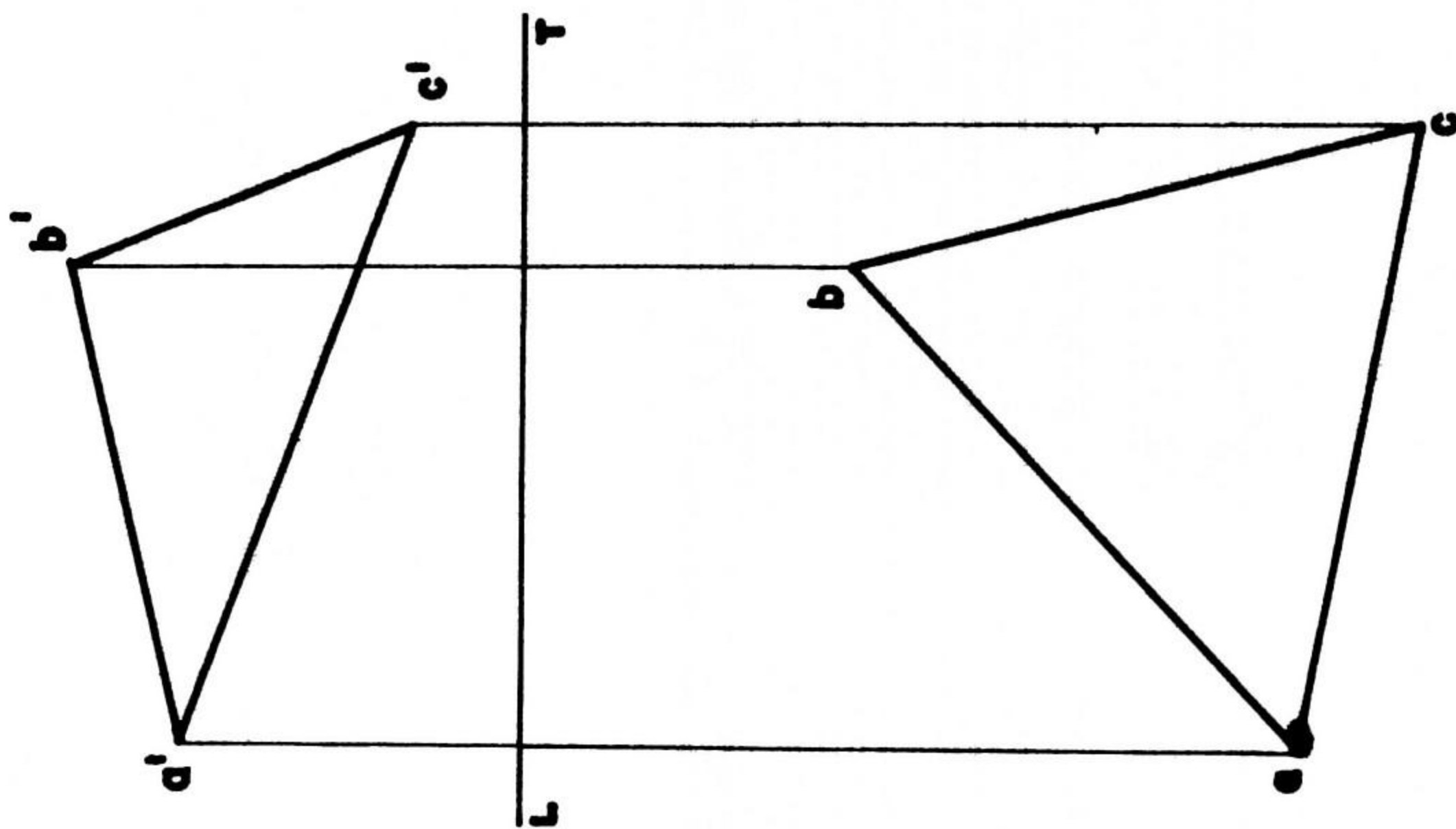

DPTO. DISEÑO BASICO		ISPJAE	
		FACULTAD DE ARQUITECTURA	
ASIGNATURA	TEMA		
DOC.	ALUM.	No.	GRUPO.
FECHA			EVAL.

4.3 DETERMINAR LA FORMA REAL DEL TRIANGULO ABC POR EL METODO DE GIRO.

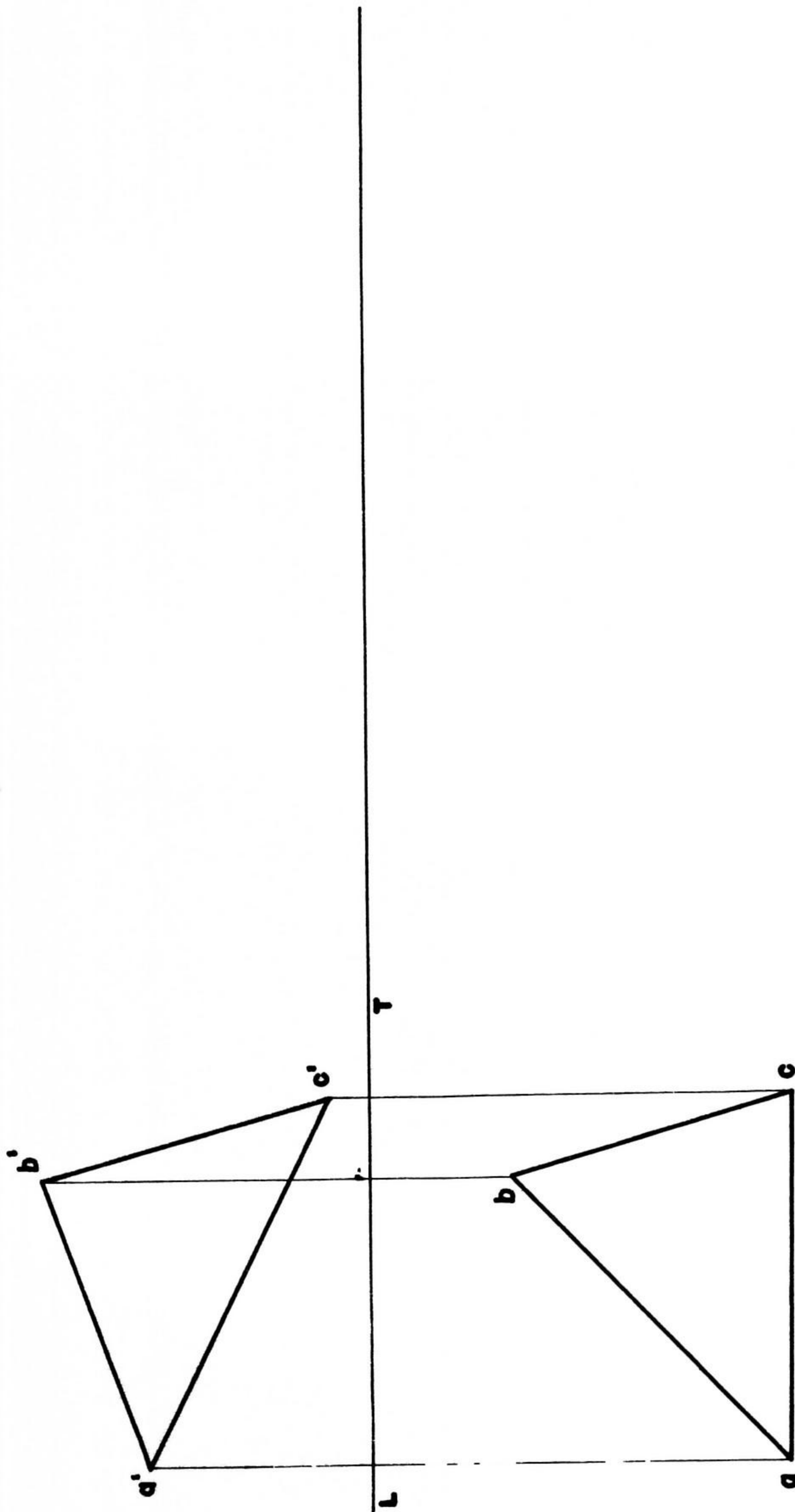

DPTO. DISEÑO BASICO		ISPJAE FACULTAD DE ARQUITECTURA	
ASIGNATURA	TEMA		
DOC.	ALUM.	No.	GRUPO.
FECHA			EVAL.

4.4 DETERMINAR LA FORMA REAL DEL TRIANGULO ABC POR EL METODO DE ABATIMIENTO.

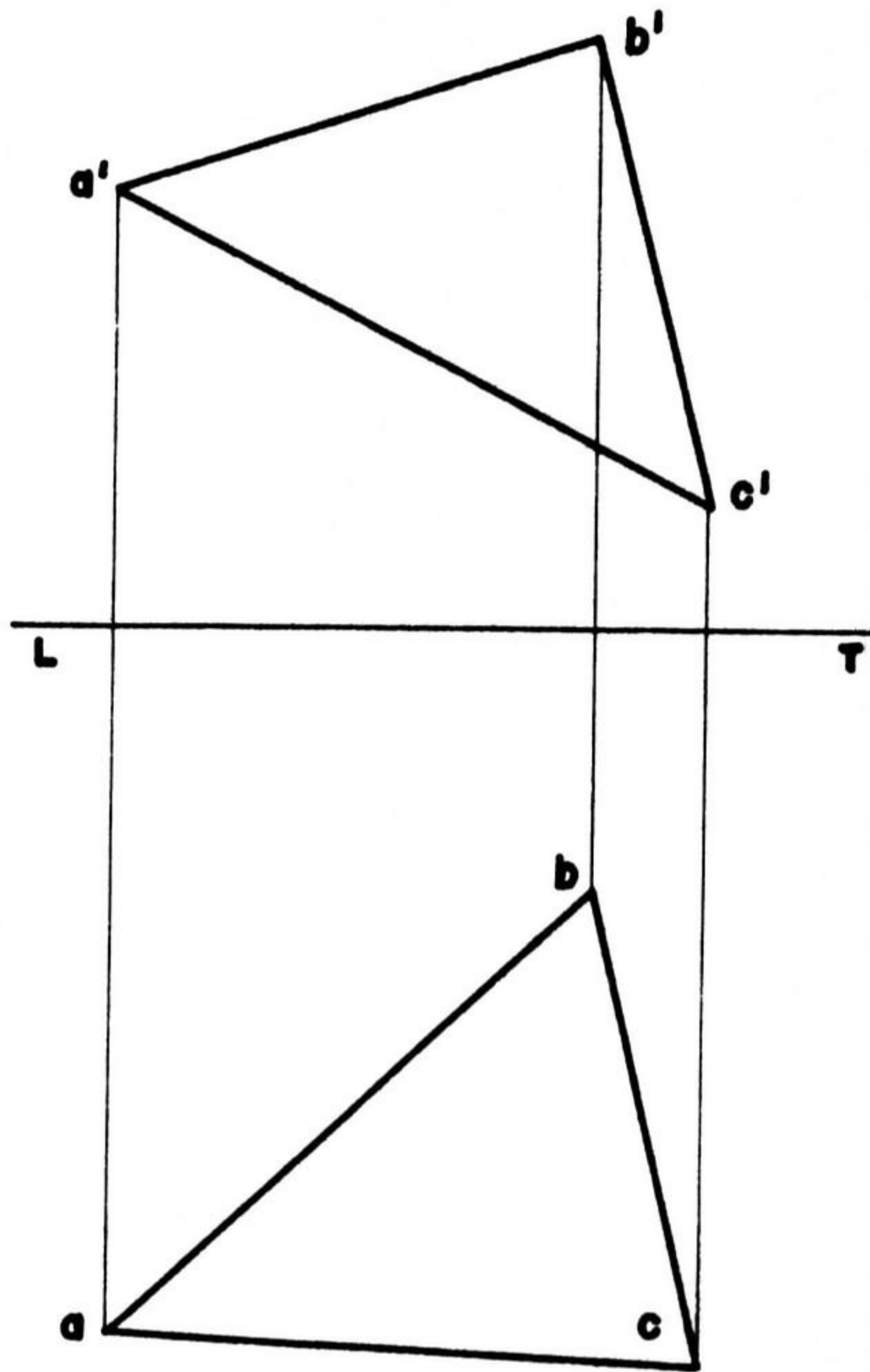

DPTO. DISEÑO BASICO		ISPJAE		FACULTAD DE ARQUITECTURA	
ASIGNATURA	TEMA				
DOC.	ALUM.	No.	GRPO.		
FECHA				EVAL.	

5.2.3 DIBUJAR : VISTA LATERAL Y EL ISOMETRICO

A

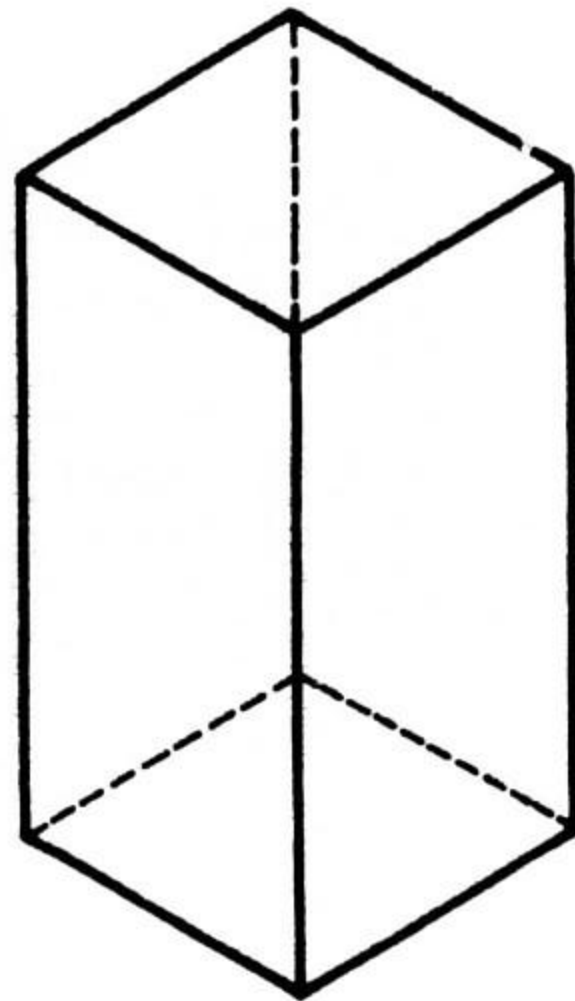
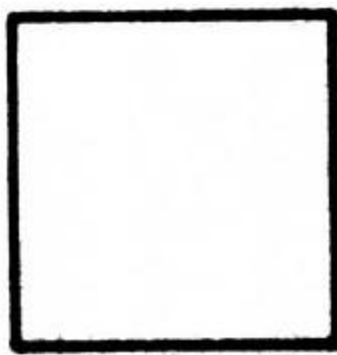
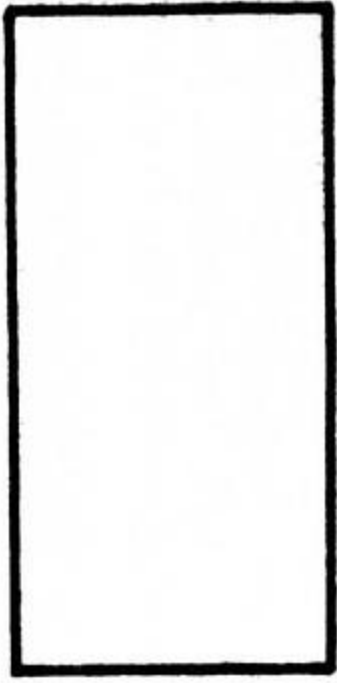

B

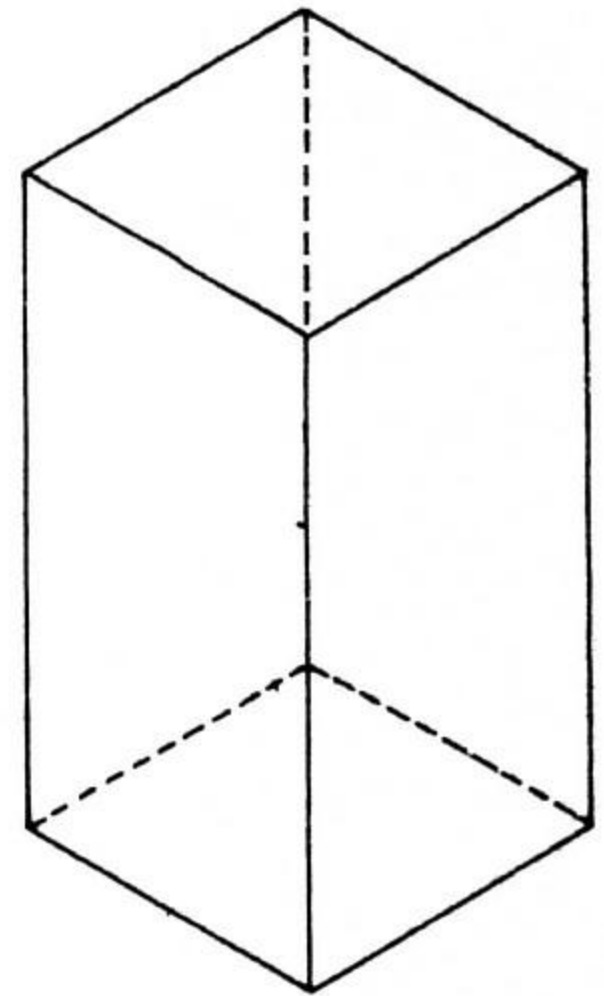
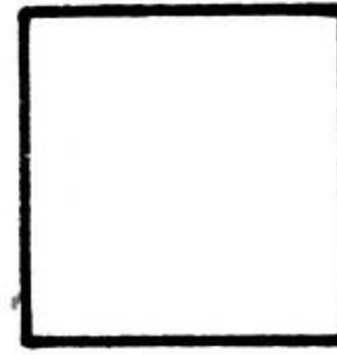
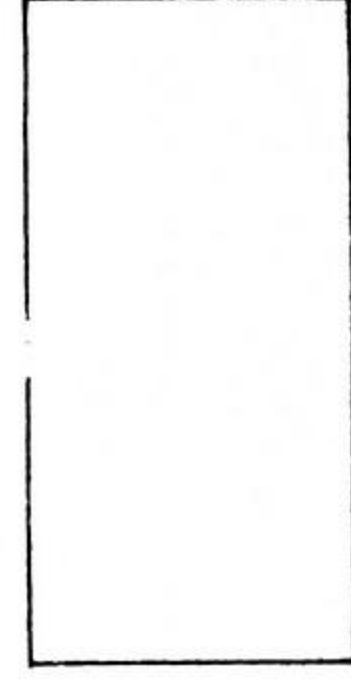
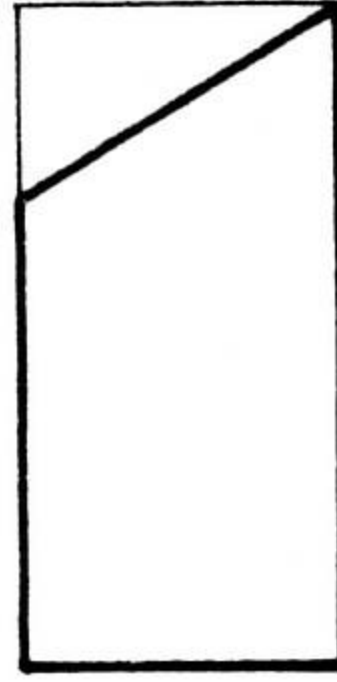

C

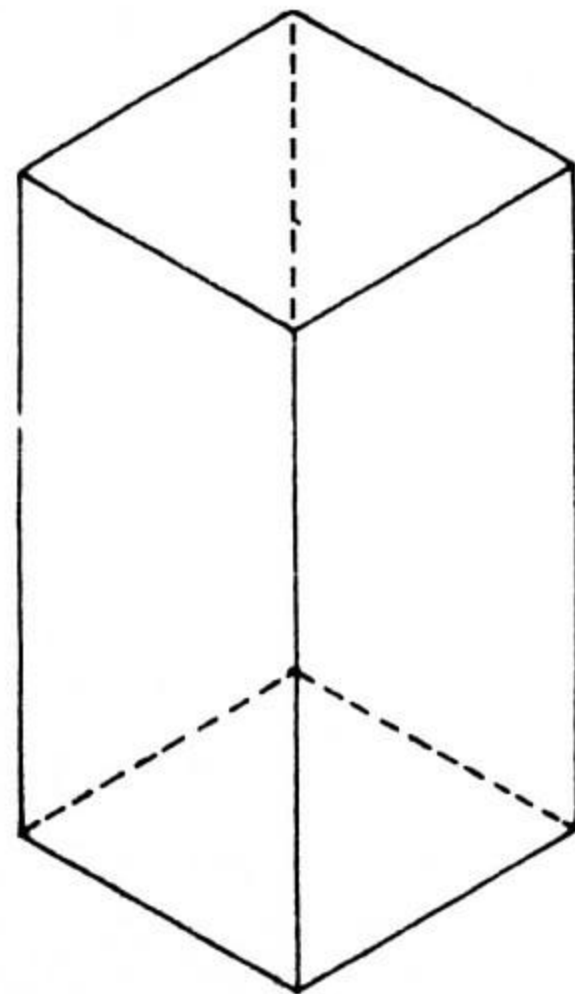
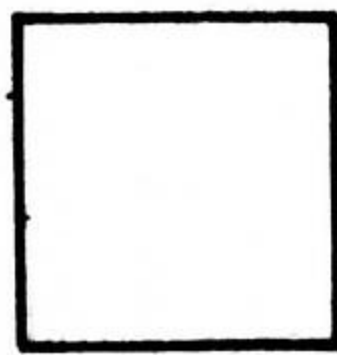
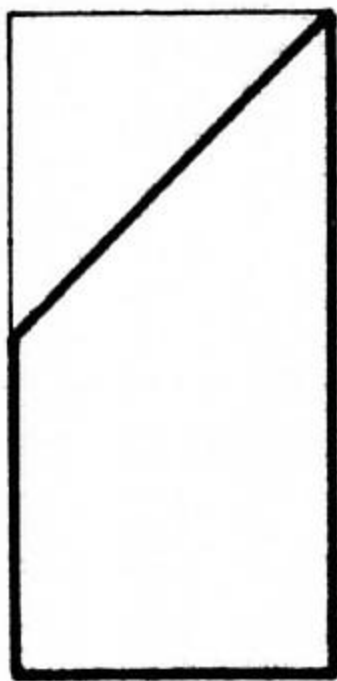

D

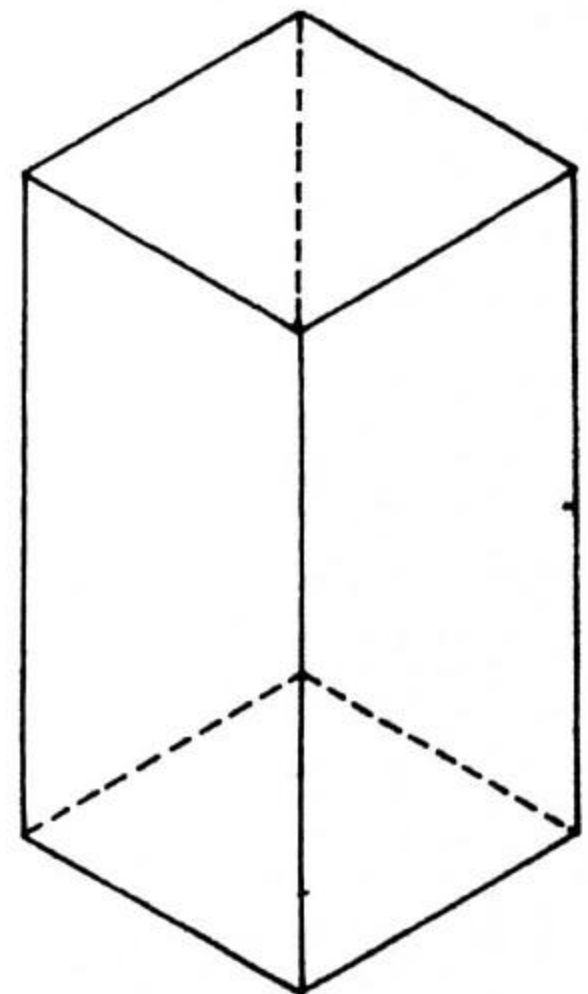
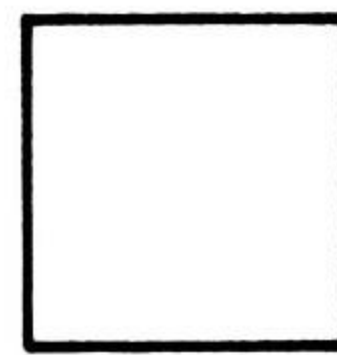
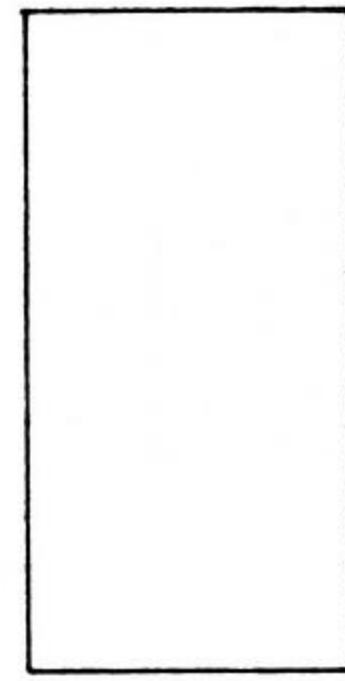
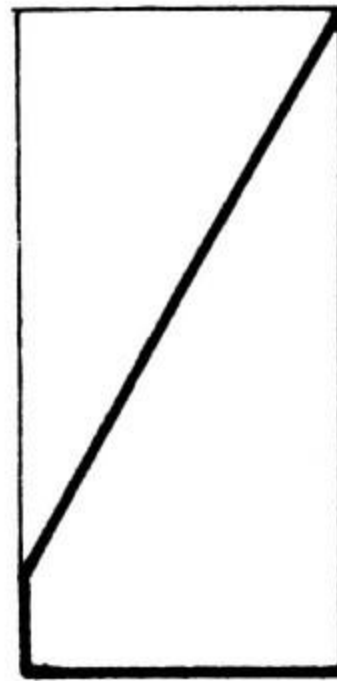

DPTO. DISEÑO BASICO

ISPJAE FACULTAD DE ARQUITECTURA

ASIGNATURA	TEMA		
DOC.	ALUM.	No.	GPO:
FECHA			EVAL.



5.3.3 CUBO.-RAYAR LAS REGIONES REQUERIDAS

REGION ANTERIOR

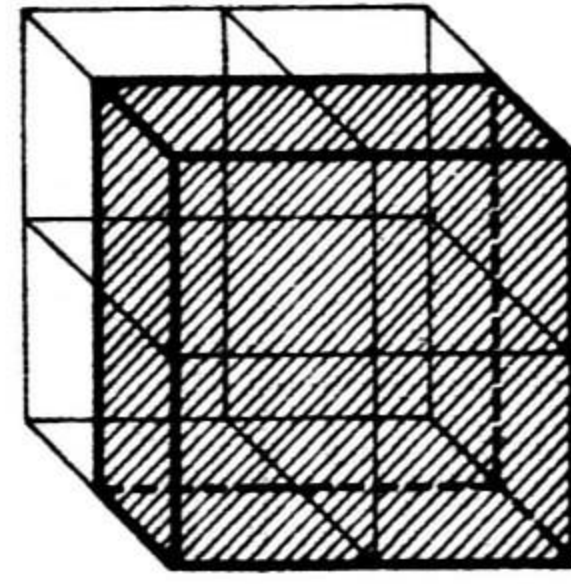
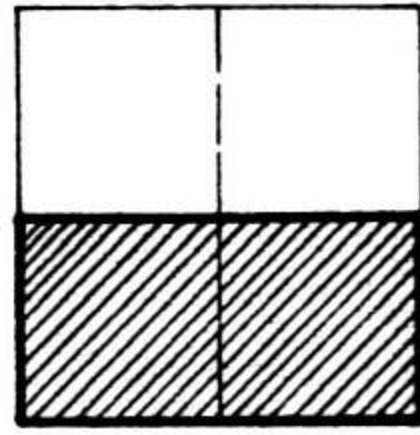
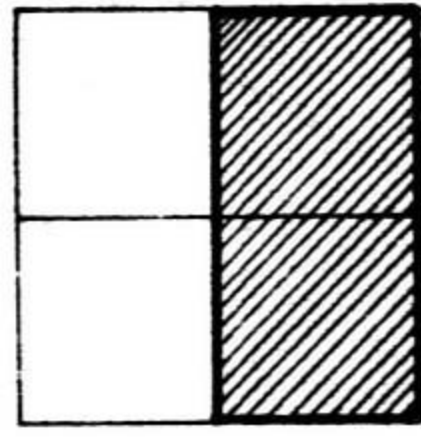
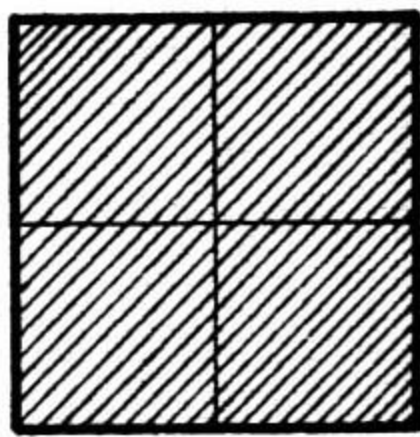

REGION SUPERIOR

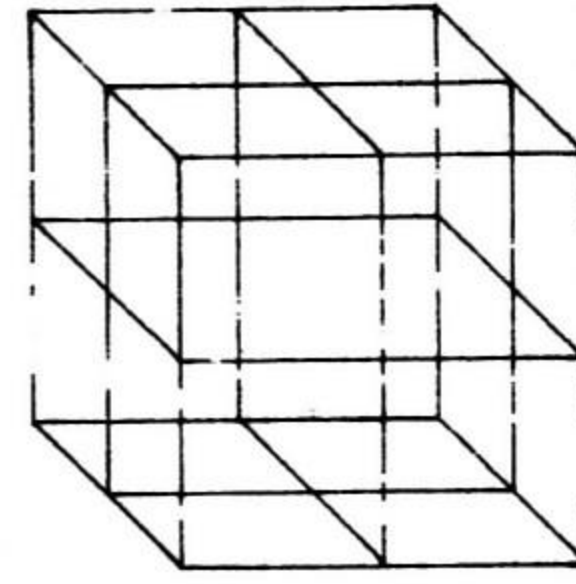
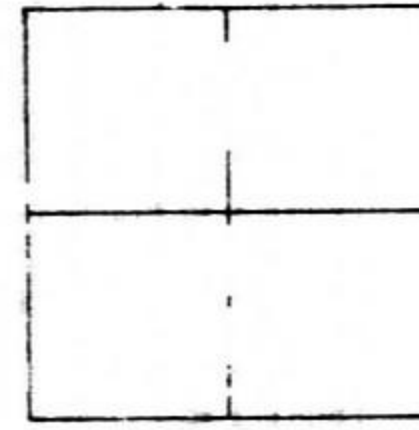
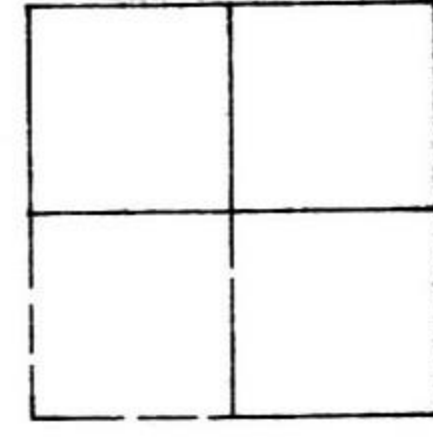

REGION IZQUIERDA

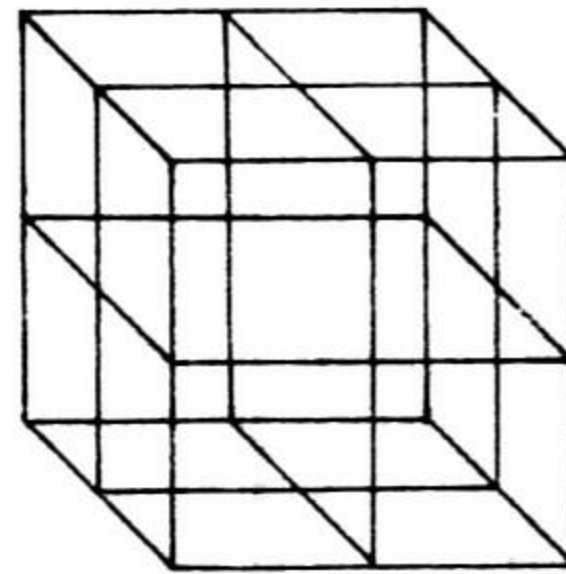
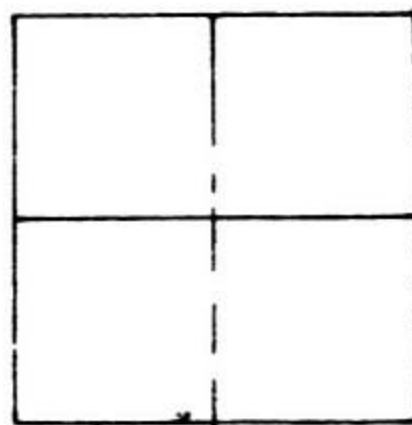
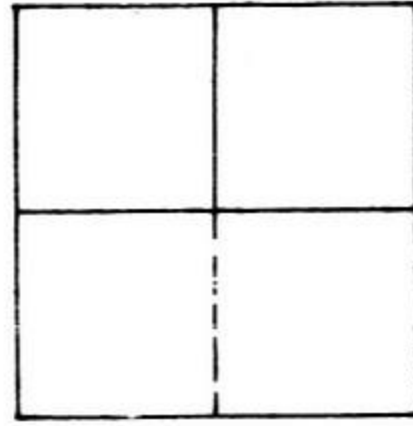
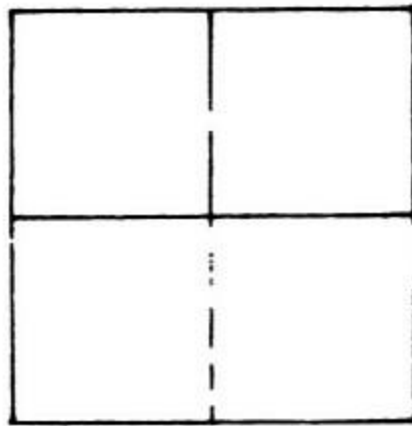

REGION POST. SUP. IZQUIERDA

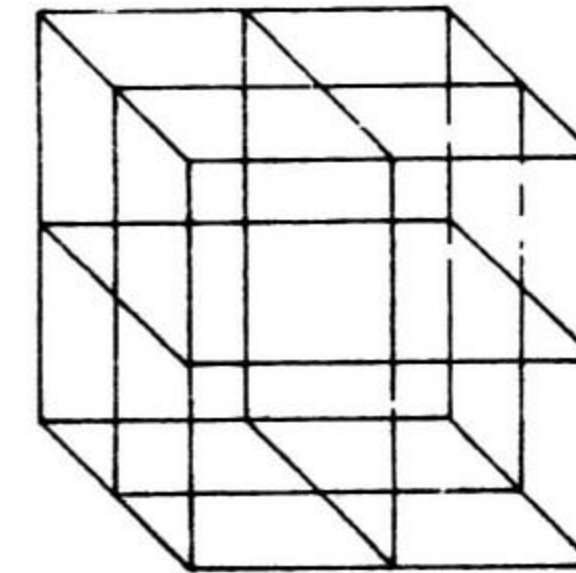
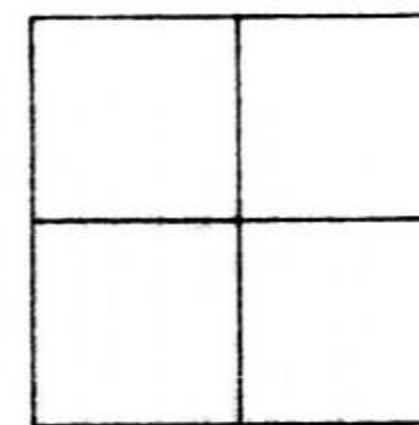
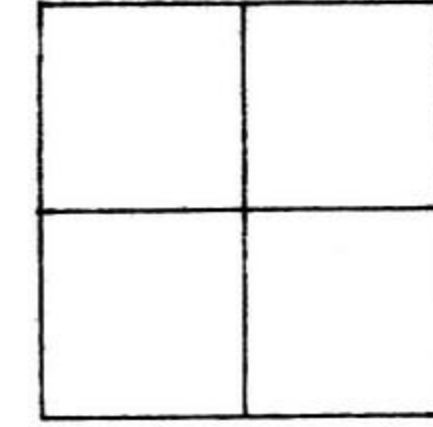
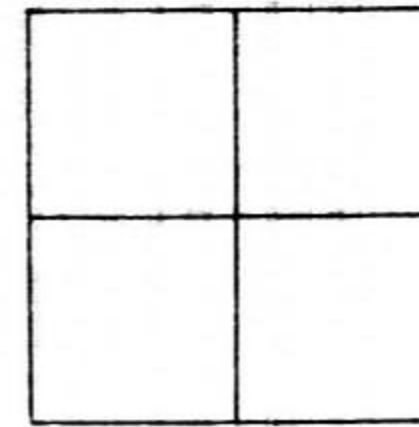

REGION POST. INF. IZQUIERDA

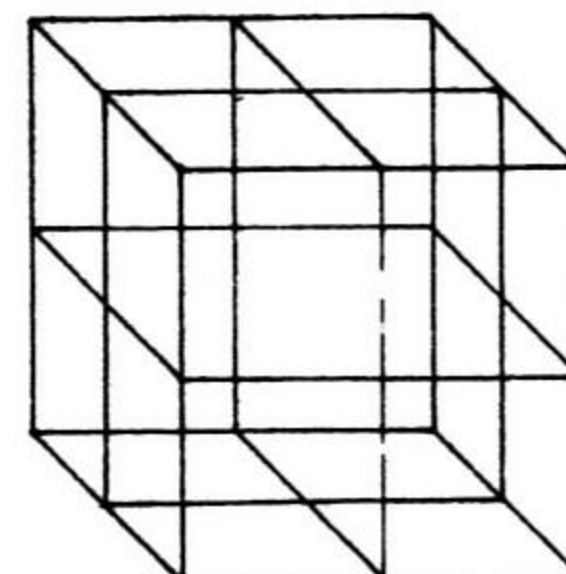
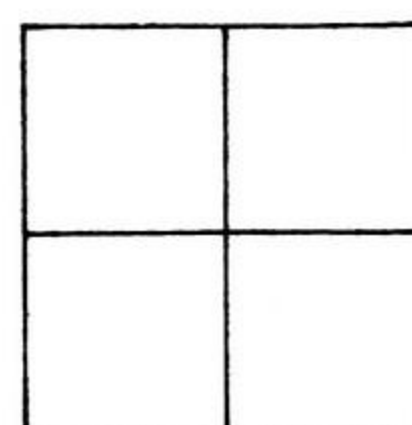
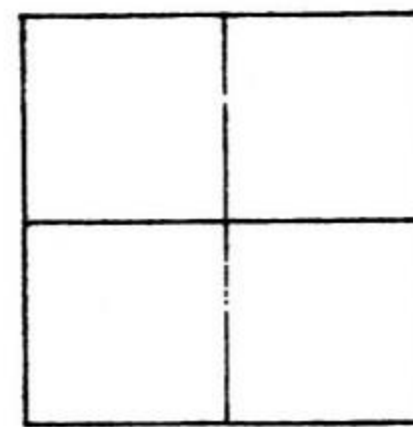
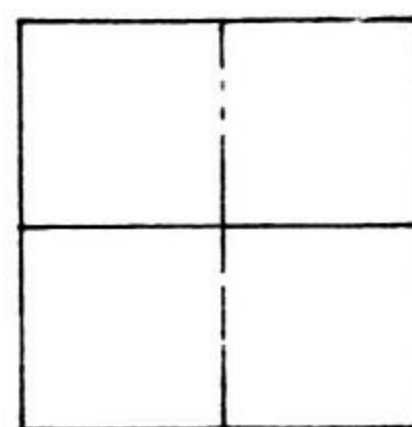

REGION ANT. INF. IZQUIERDA

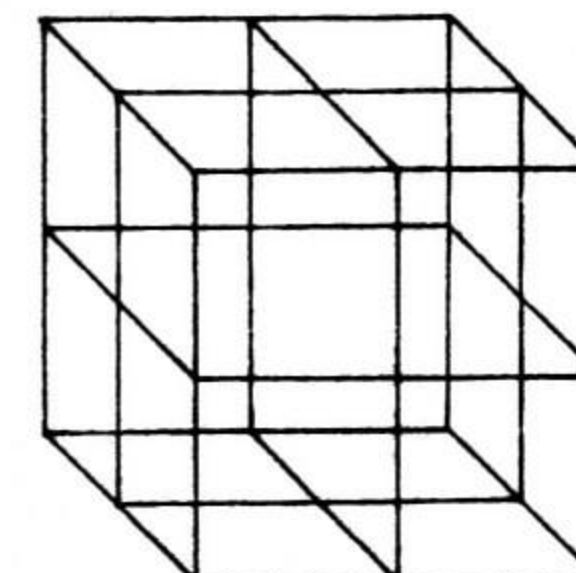
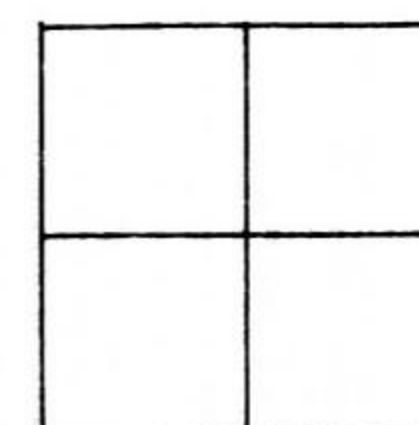
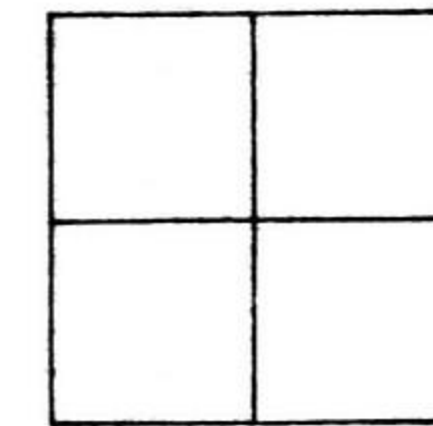
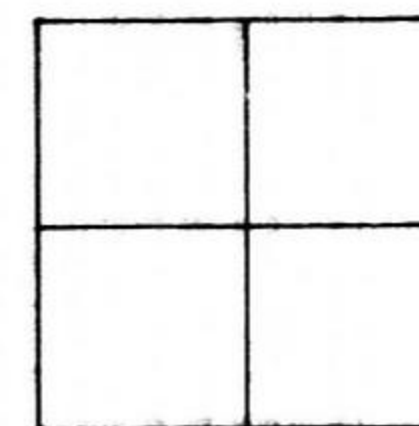

DPTO. DISEÑO BASICO

ISPJAE FACULTAD DE ARQUITECTURA

ASIGNATURA

TENA

DOC.

ALUM.

№.

GPO.

FECHA

EVAL.





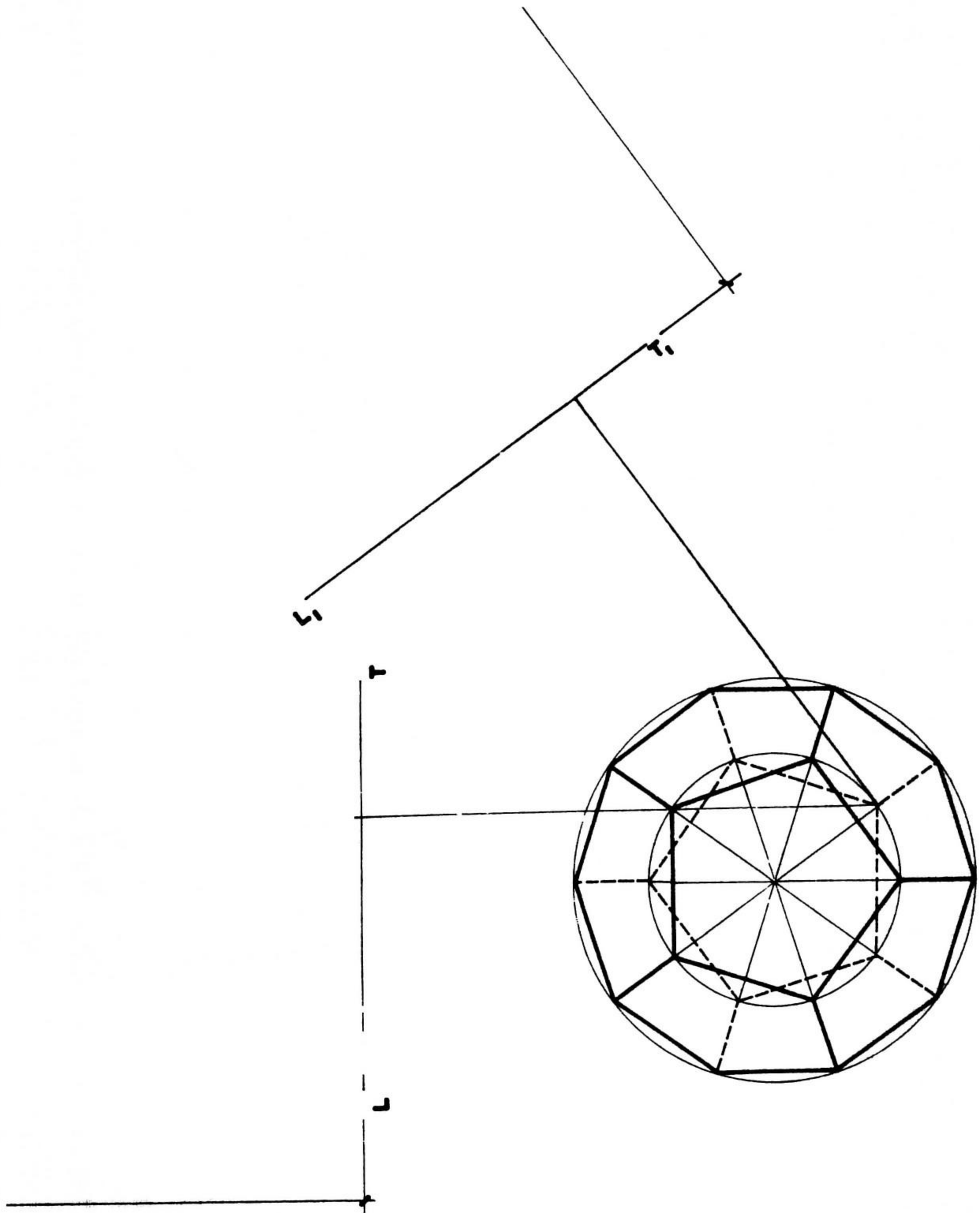



5.3 DODECAEDRO.- DIBUJAR VISTA DE FRENTE Y HACER CAMBIO DE PLANO

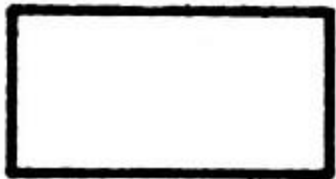
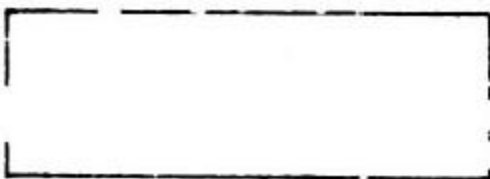
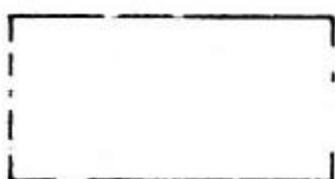
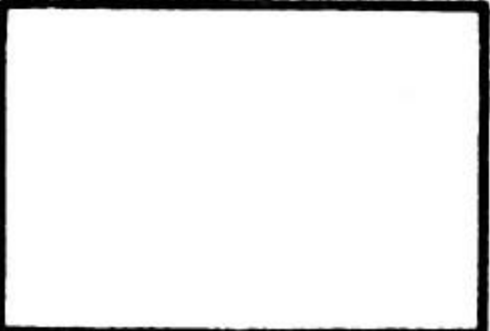
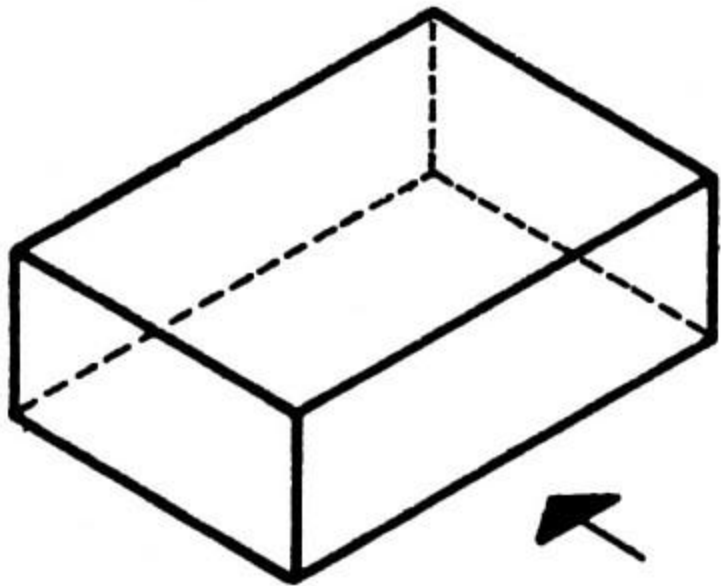

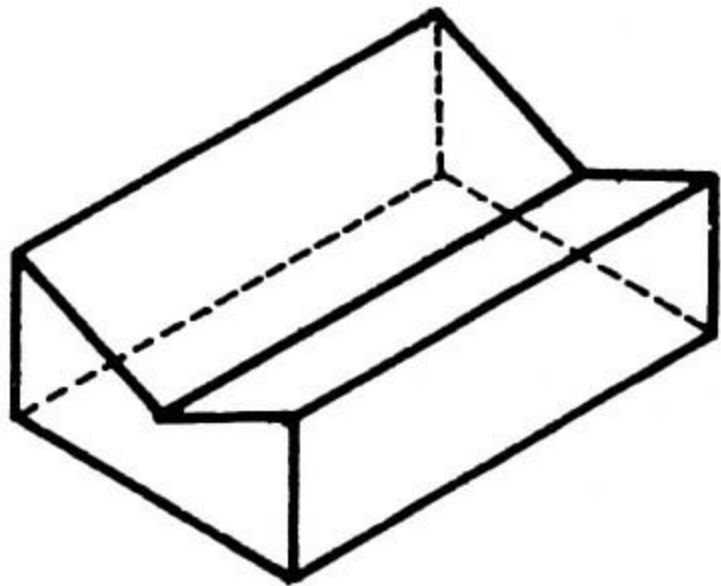
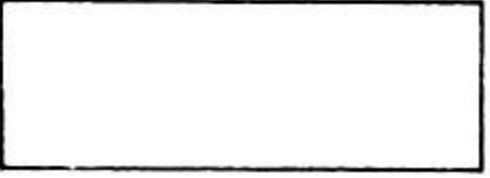
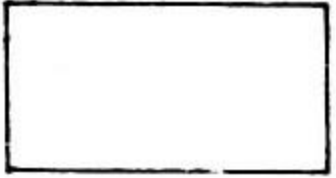
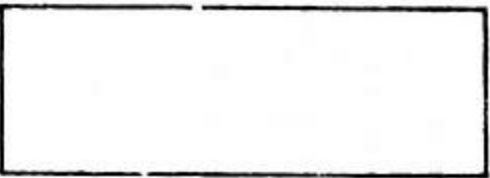
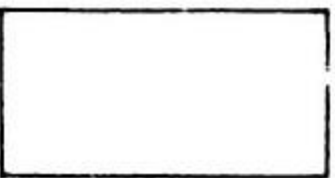
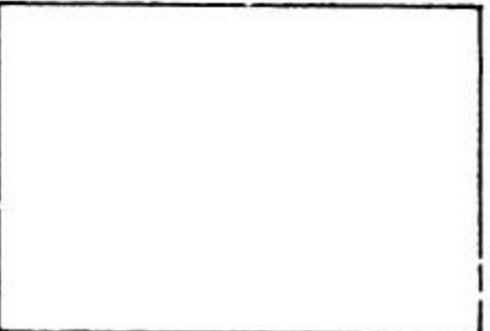
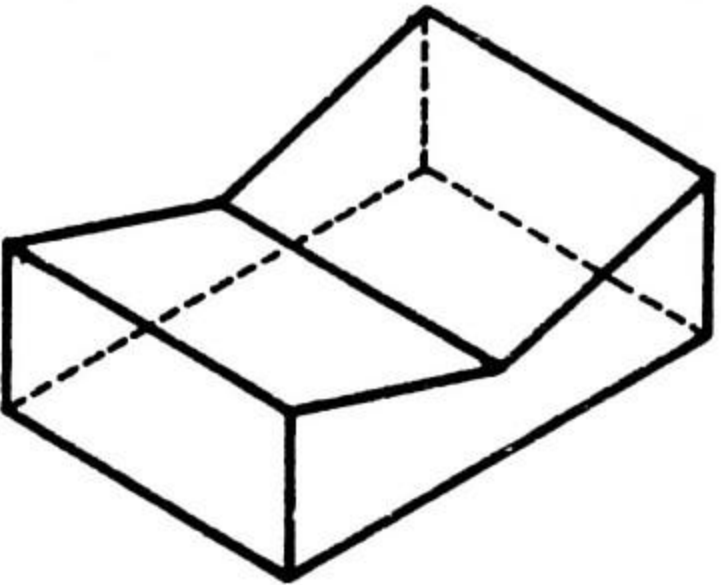
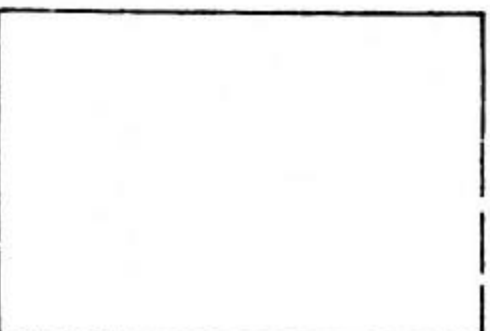
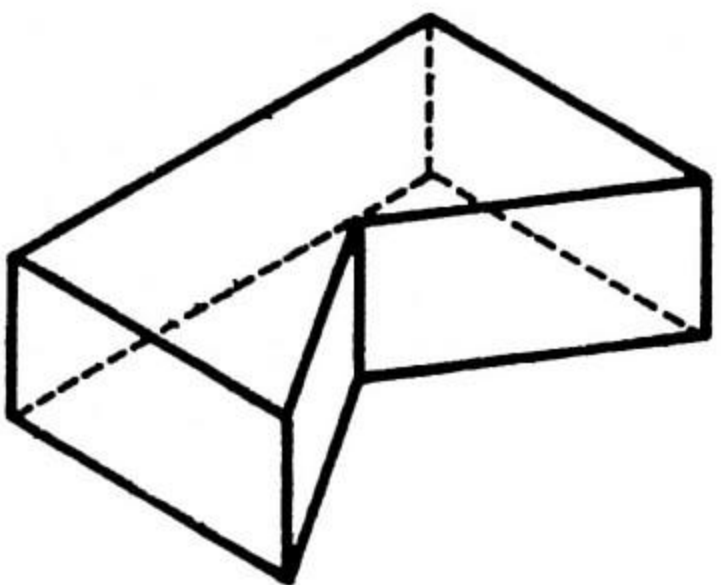
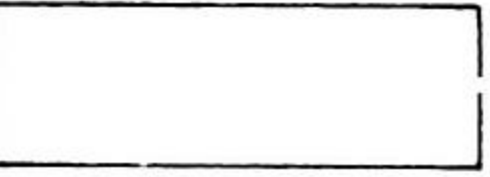
DPTO. DISEÑO BASICO		ISPJAE FACULTAD DE ARQUITECTURA		D D D
ASIGNATURA	TEMA			
DOC	ALUM.	No.	GRUPO.	
FECHA			EVAL.	

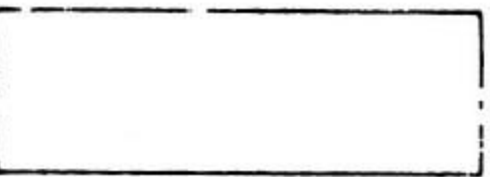
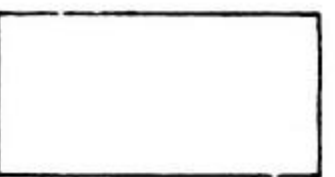
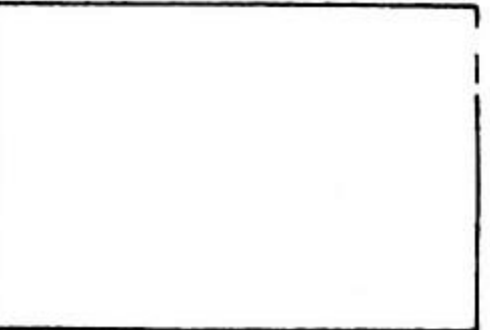
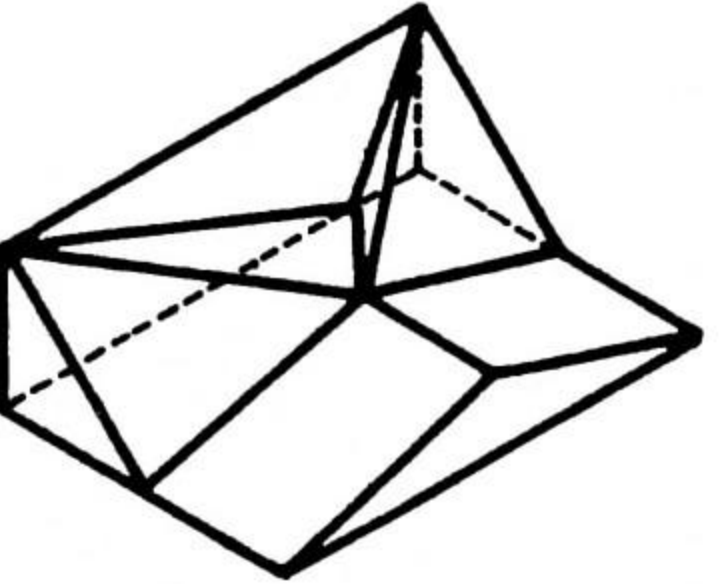
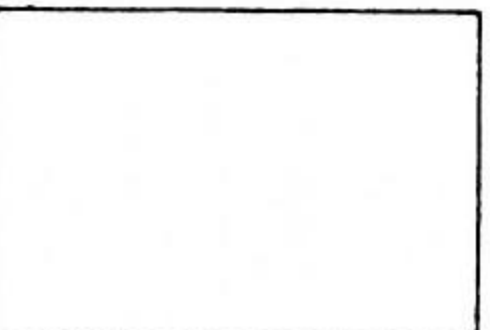
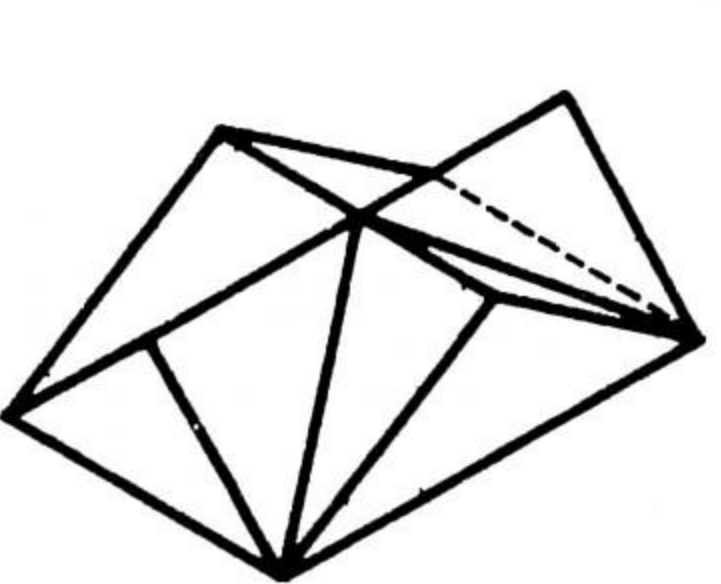
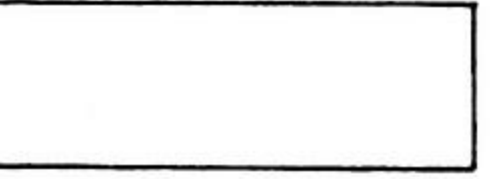
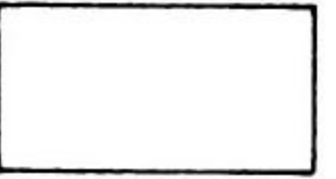
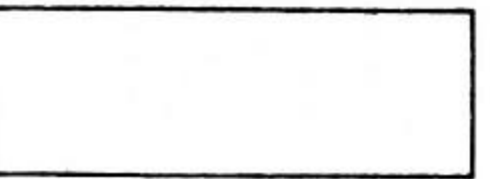
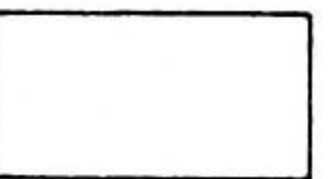
5.4.2 REPRESENTAR LAS TRES VISTAS DEL CUERPO

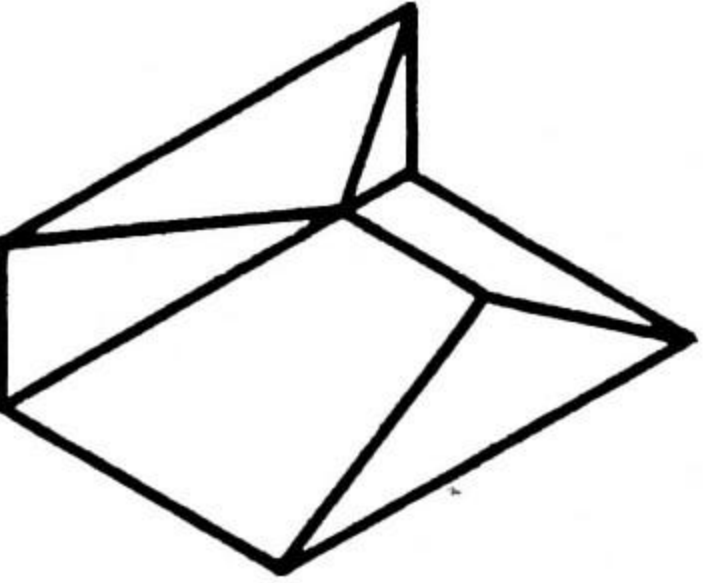
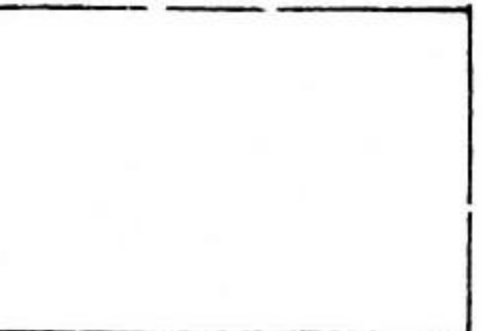
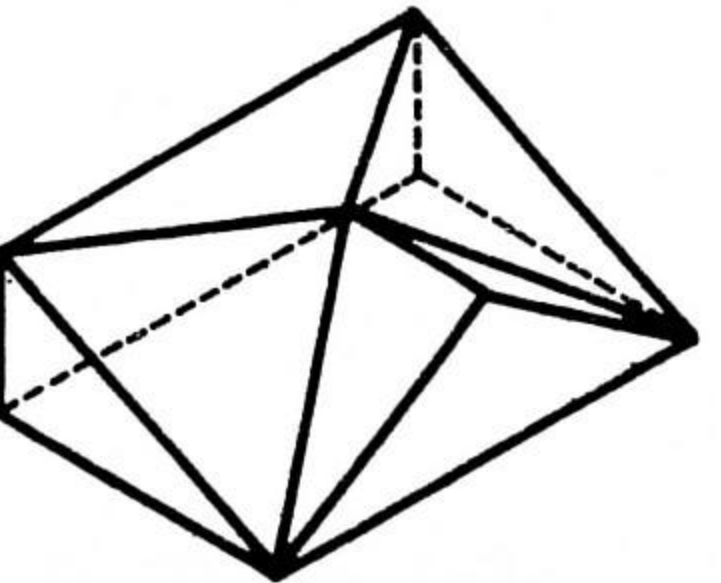
DPTO. DISEÑO BASICO

ISPJAE
FACULTAD DE ARQUITECTURA

ASIGNATURA

TEMA

DOC.

ALUM.

No.

GRUPO

FECHA

EVAL.



5.4.3 INTERPRETACION- DIBUJAR VISTA LATERAL E ISOMETRICO

DPTO. DISEÑO BASICO

ISPJAE FACULTAD DE ARQUITECTURA

ASIGNATURA

TENA

DOC.

ALUM.

No.

OPD.

FECHA

EVAL.

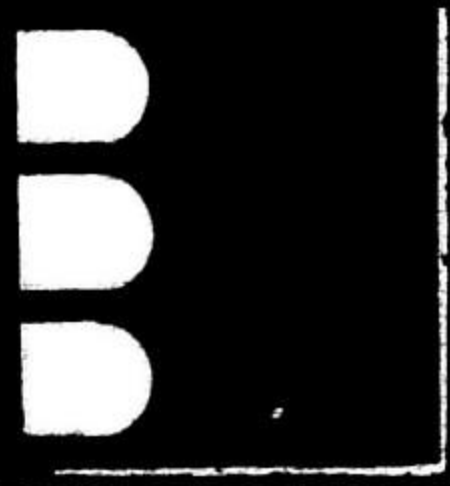

5.4.3a POLIEDROS COMPUESTOS DE CARAS ORTOGONALES - REPRESENTACIÓN

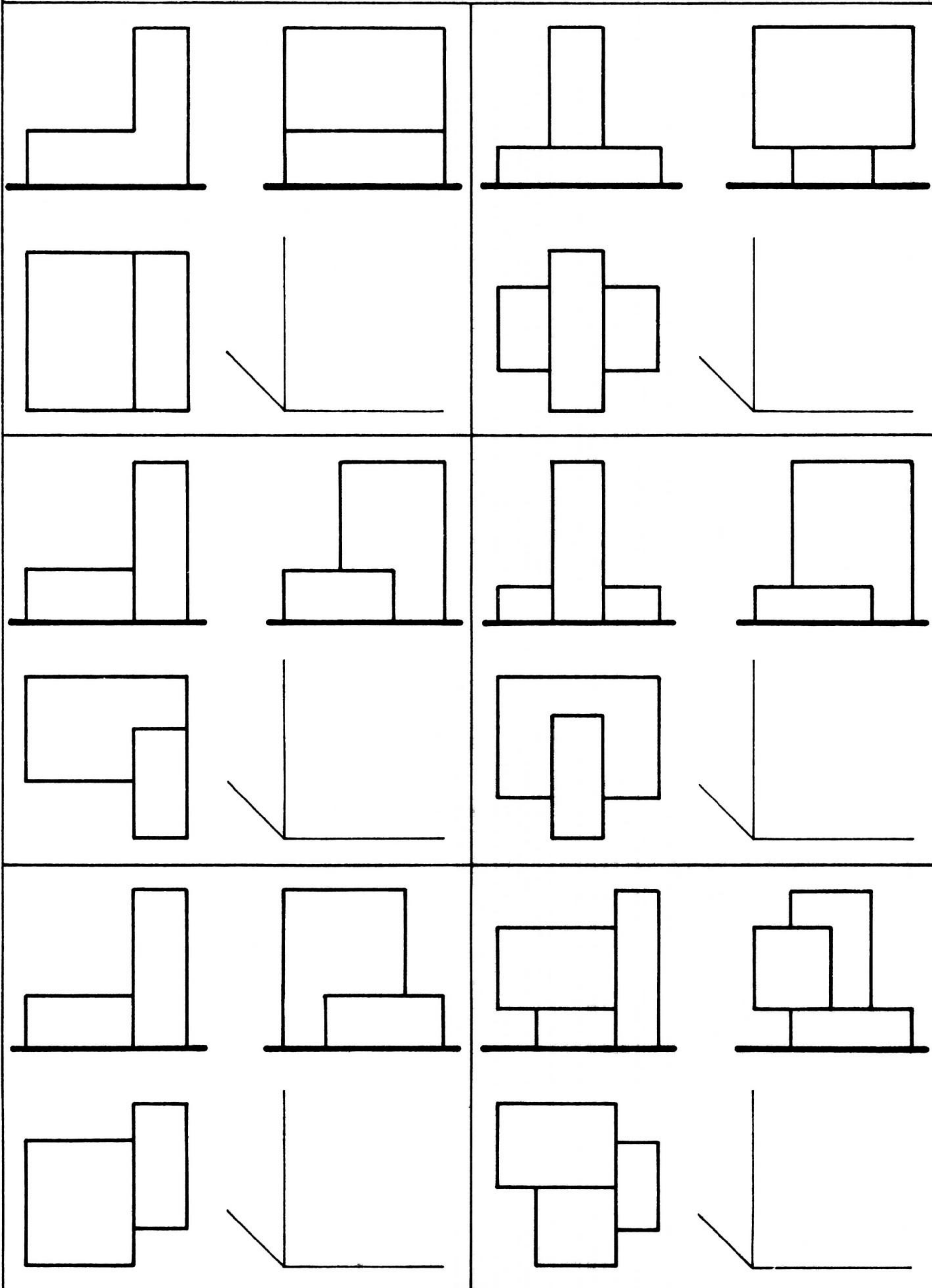

DPTO. DISEÑO BASICO

**ISPJAE
FACULTAD DE ARQUITECTURA**

ASIGNATURA	TEMA		
DOC.	ALUM.	No.	GRPO.
FECHA			EVAL.

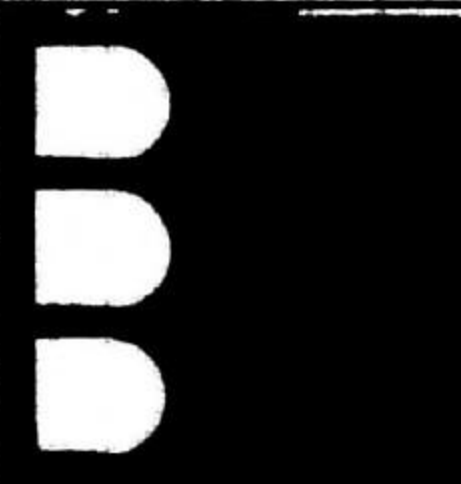

5.4.3b POLIEDROS COMPUESTOS - INTERPRETACIÓN

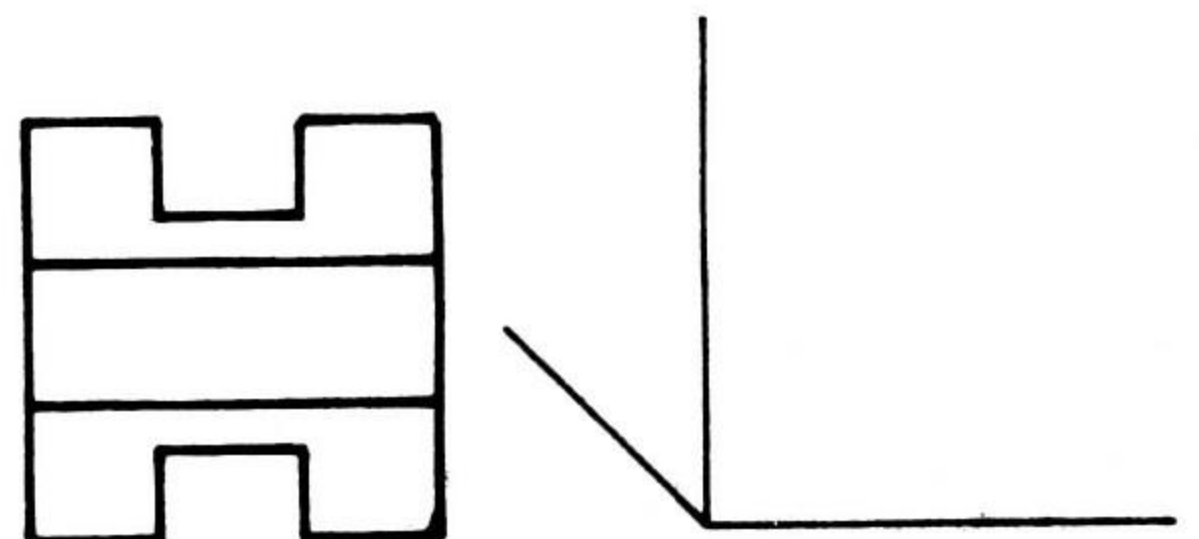
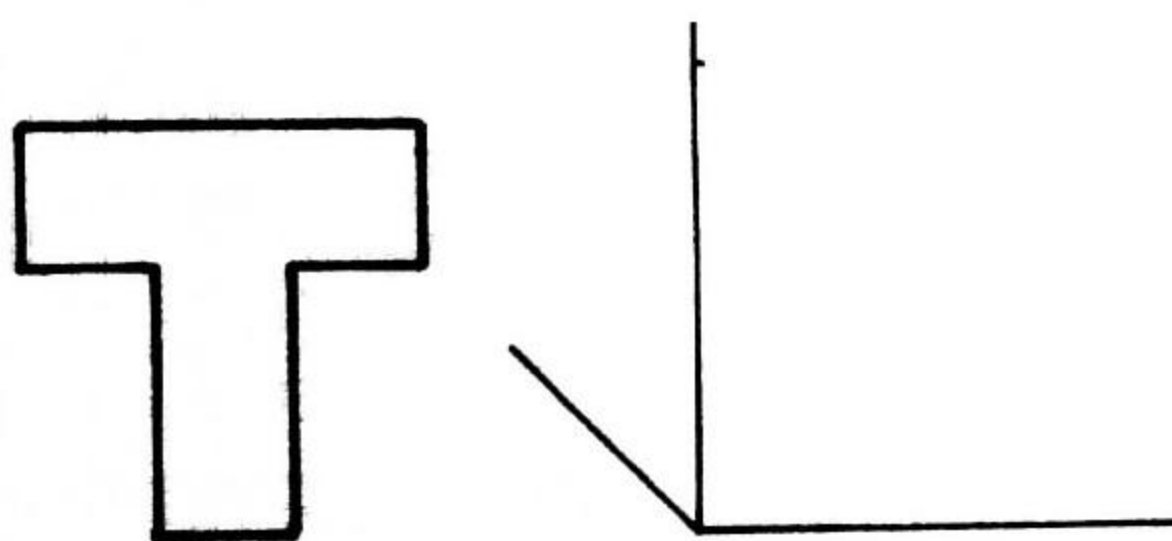
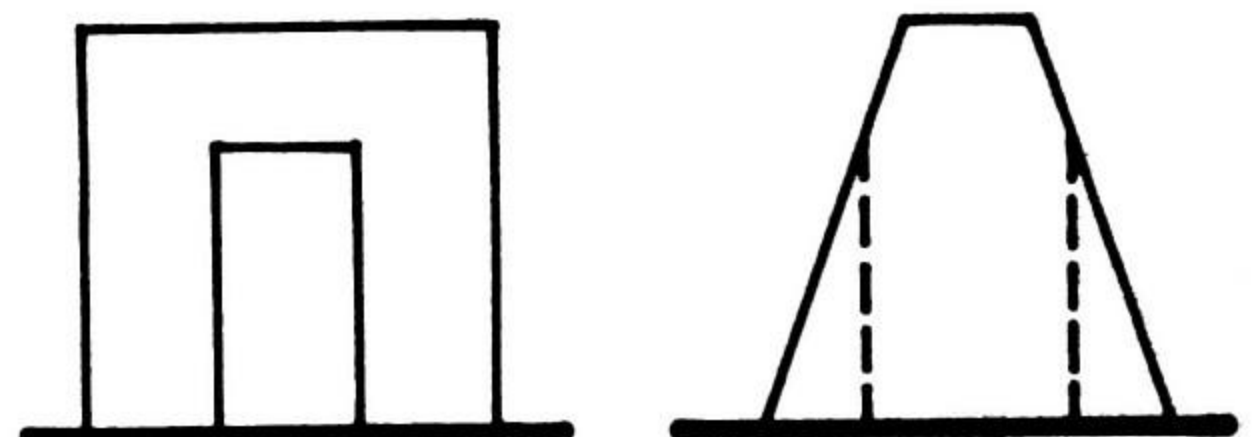
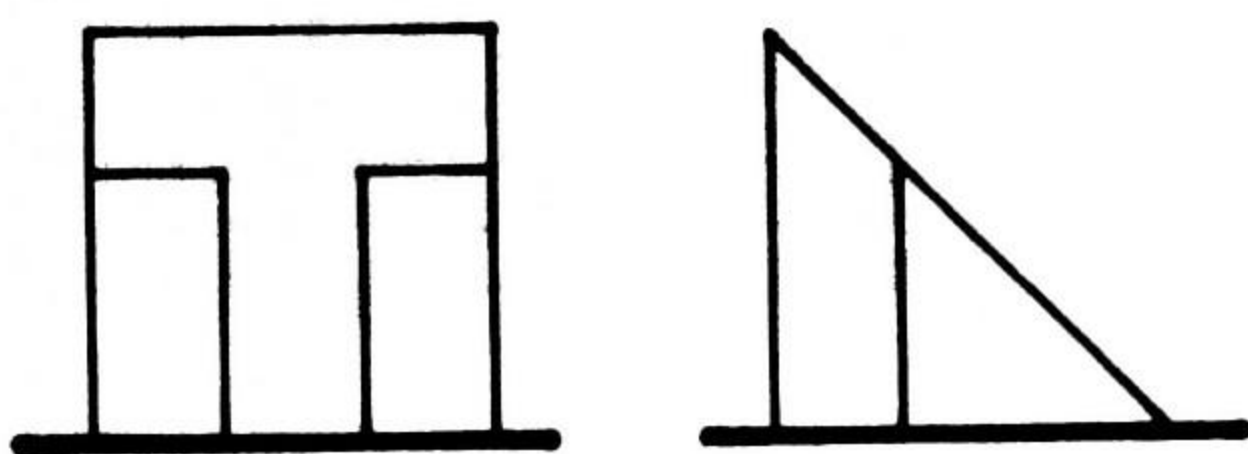
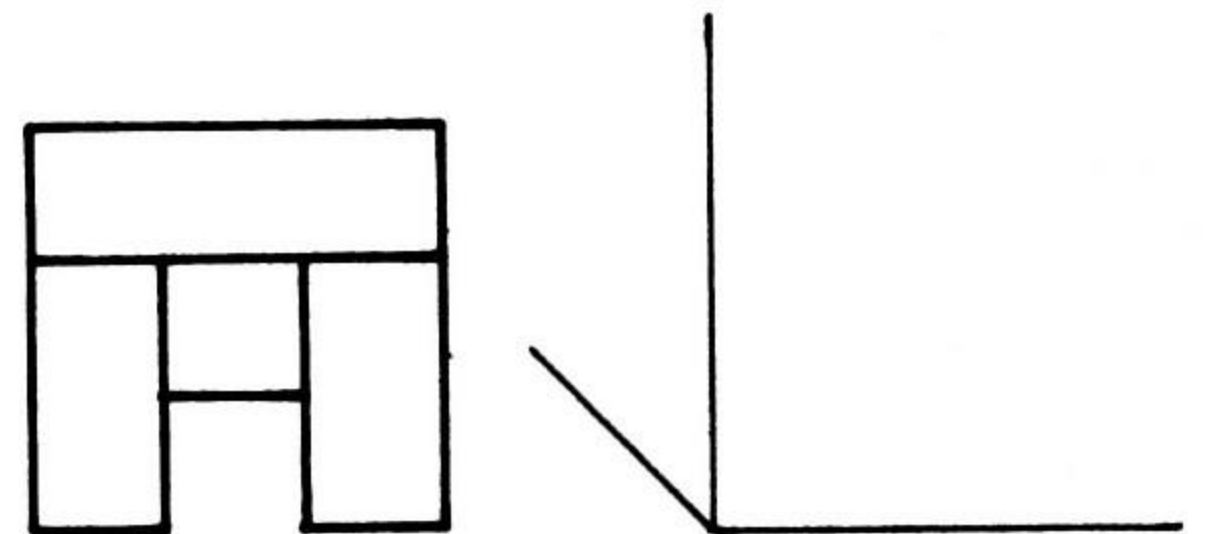
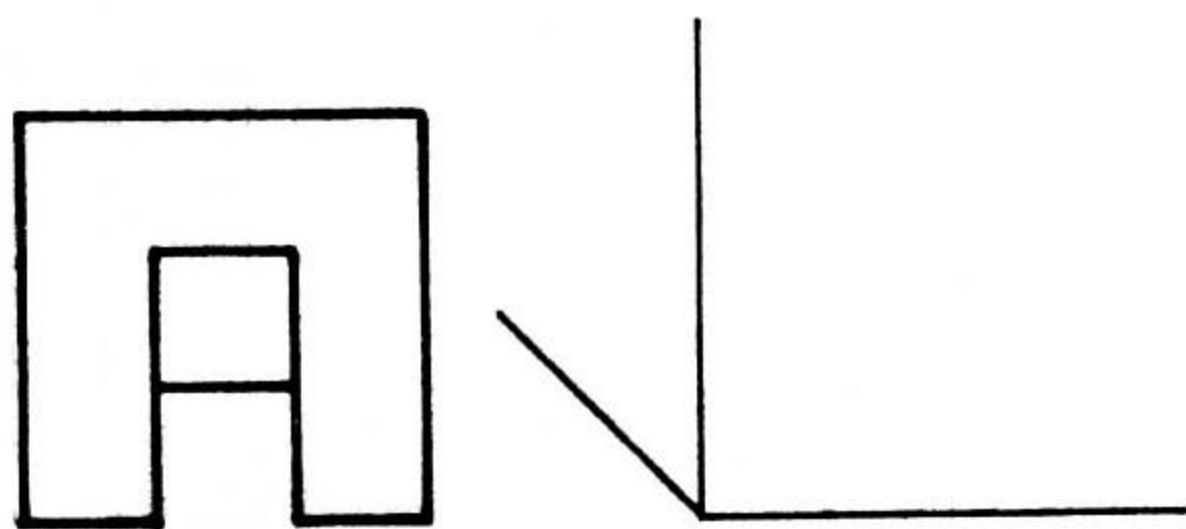
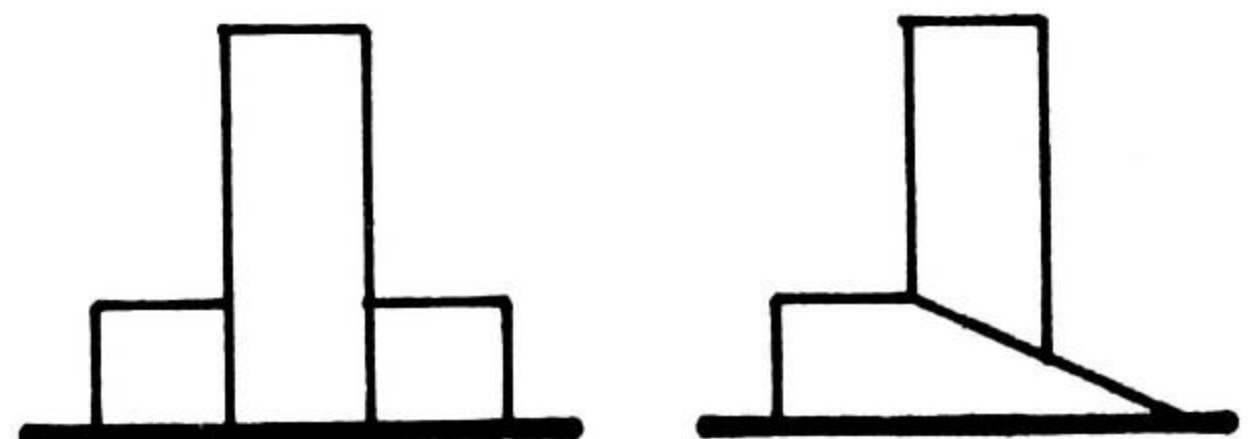
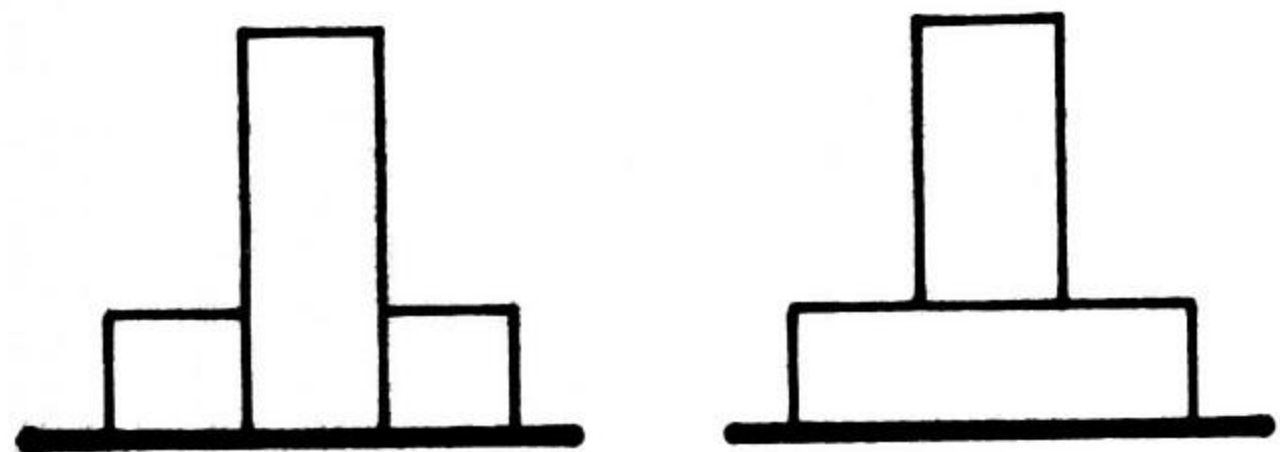
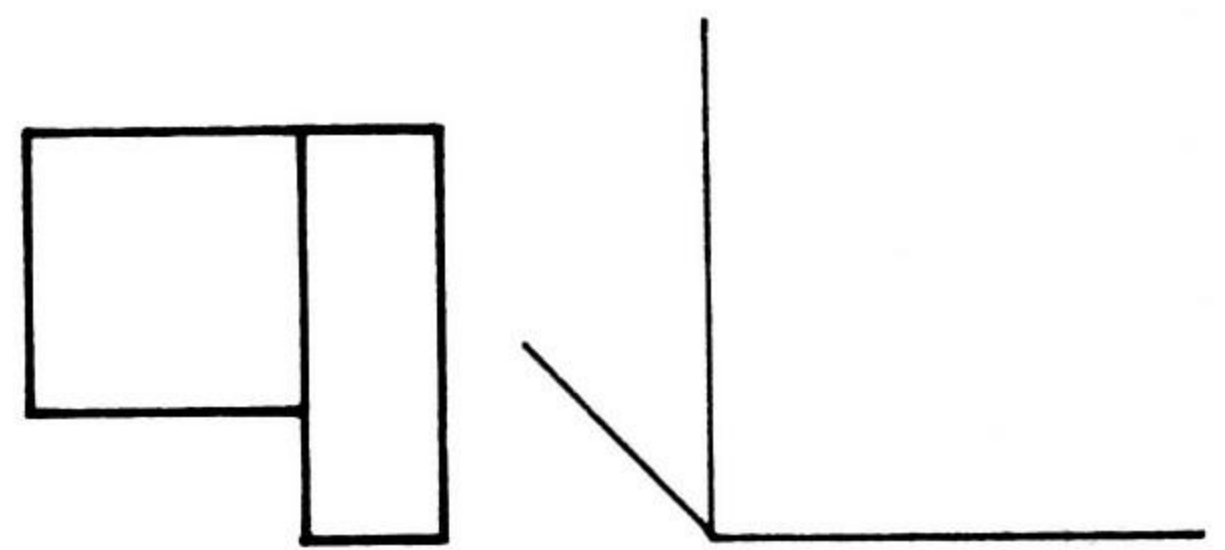
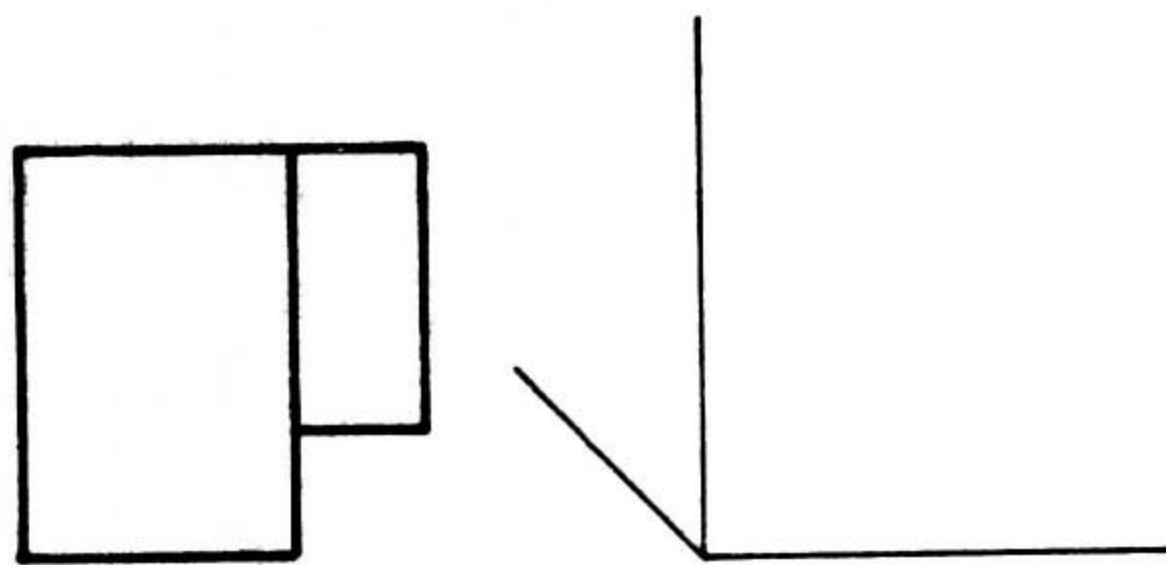
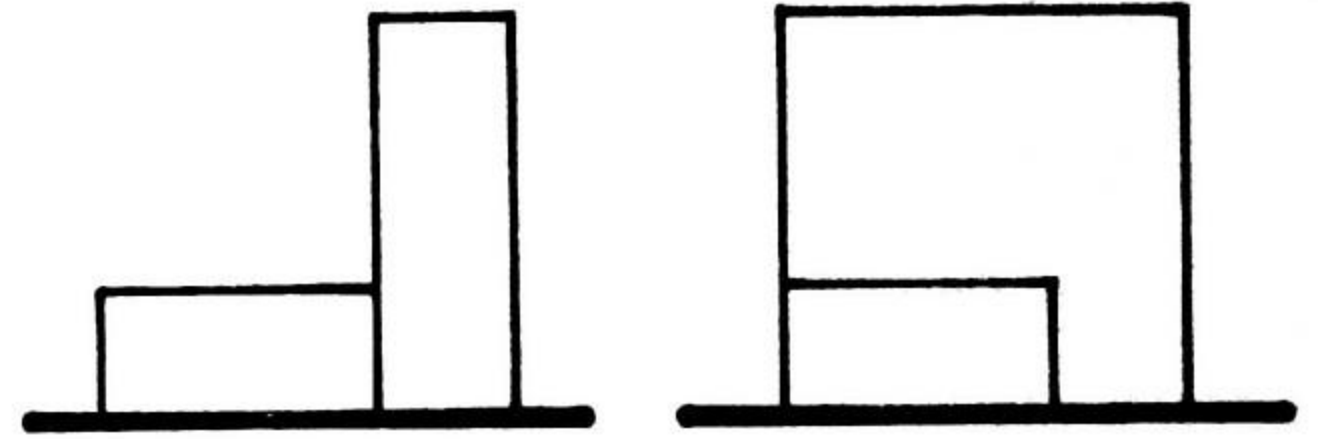
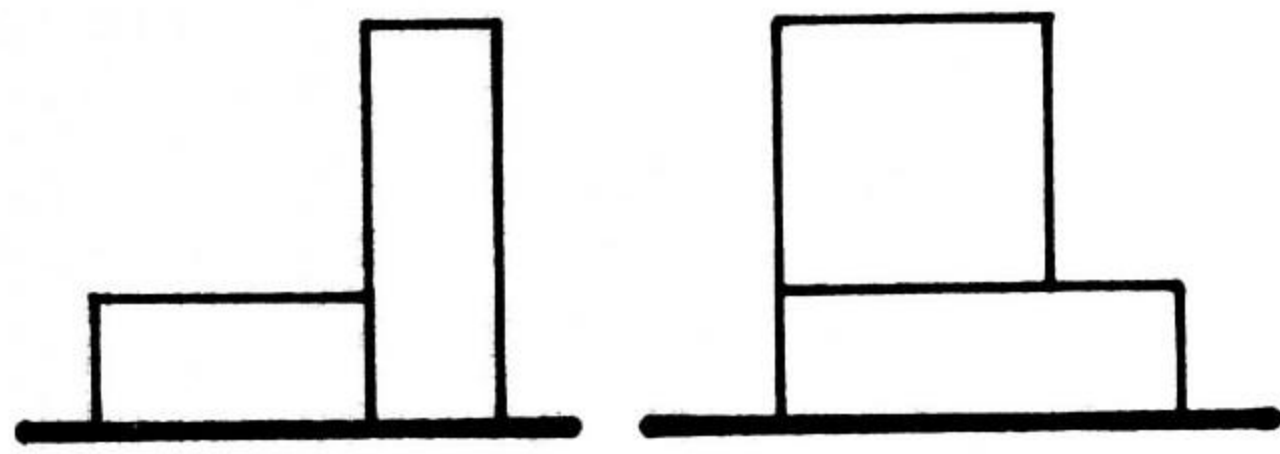

DPTO. DISEÑO BASICO

**ISPJAE
FACULTAD DE ARQUITECTURA**

ASIGNATURA

TENA

DOC.

ALUM.

No.

GRUPO

FECHA

EVAL.

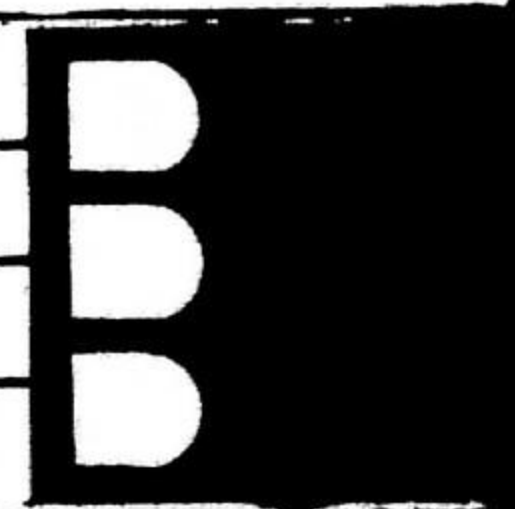

5.4.3c INTERPRETACIÓN - IDENTIFICAR EN LAS VISTAS RESTANTES:

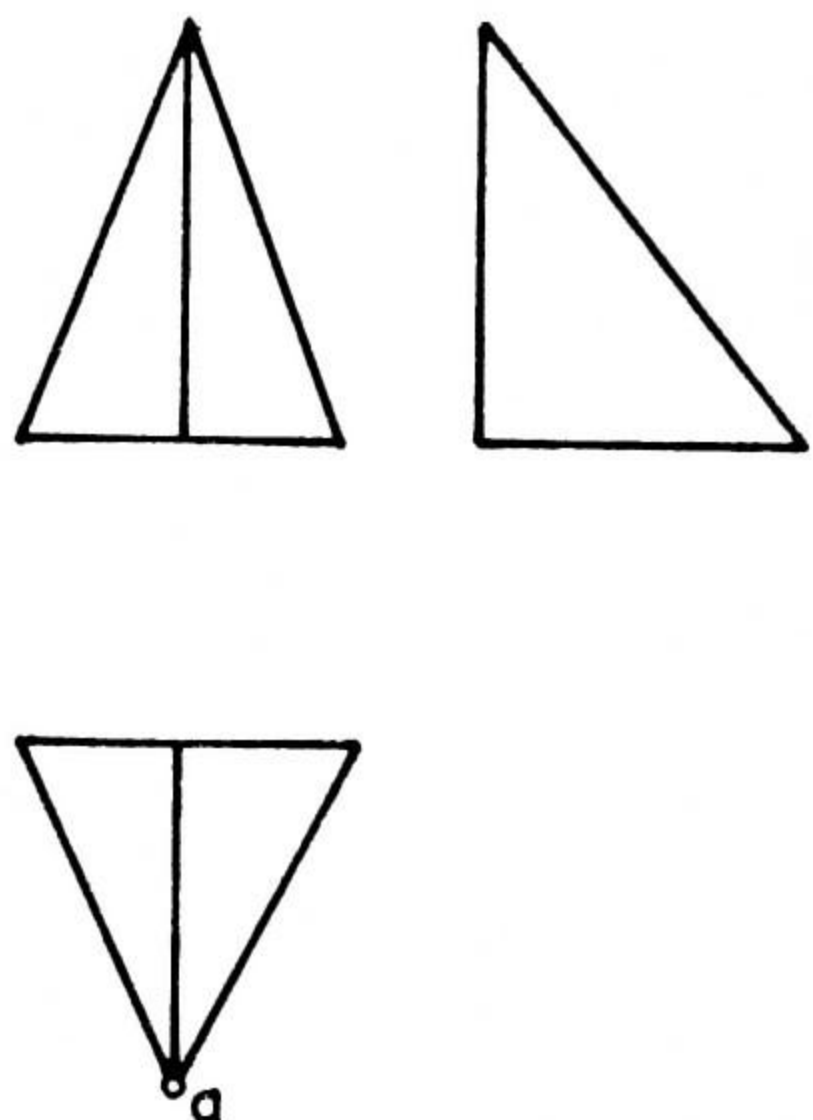
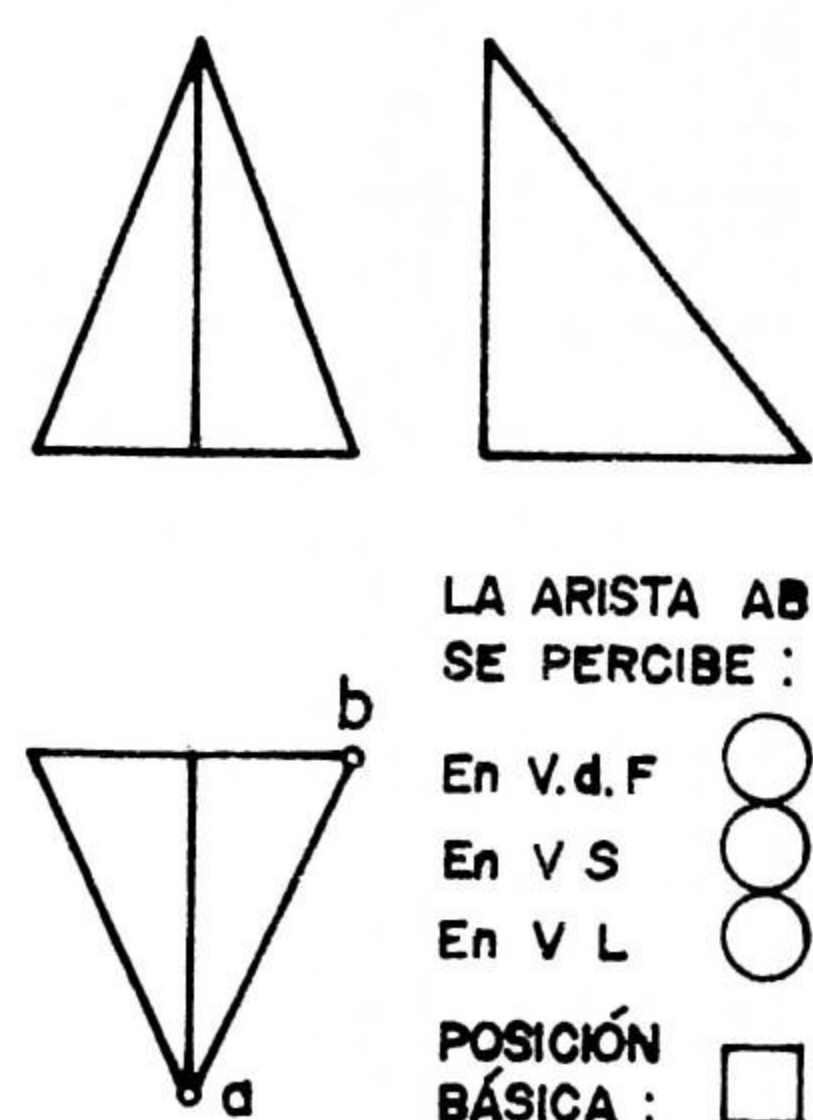
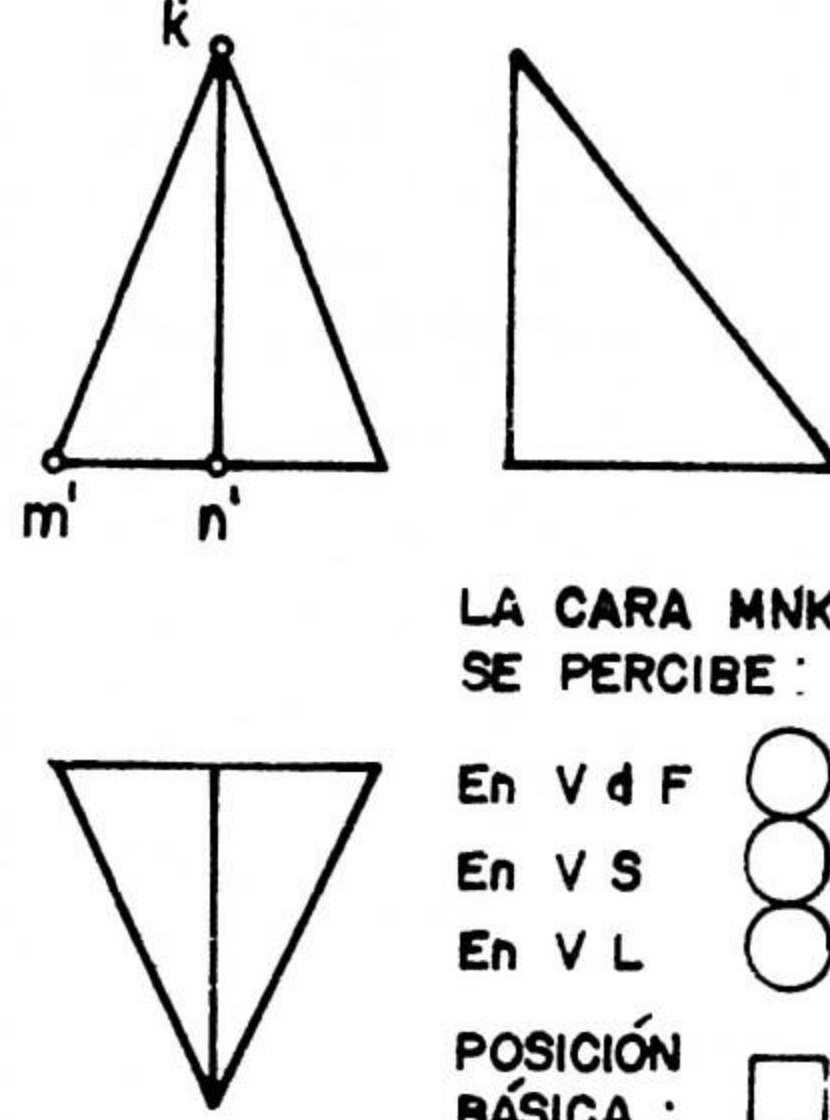
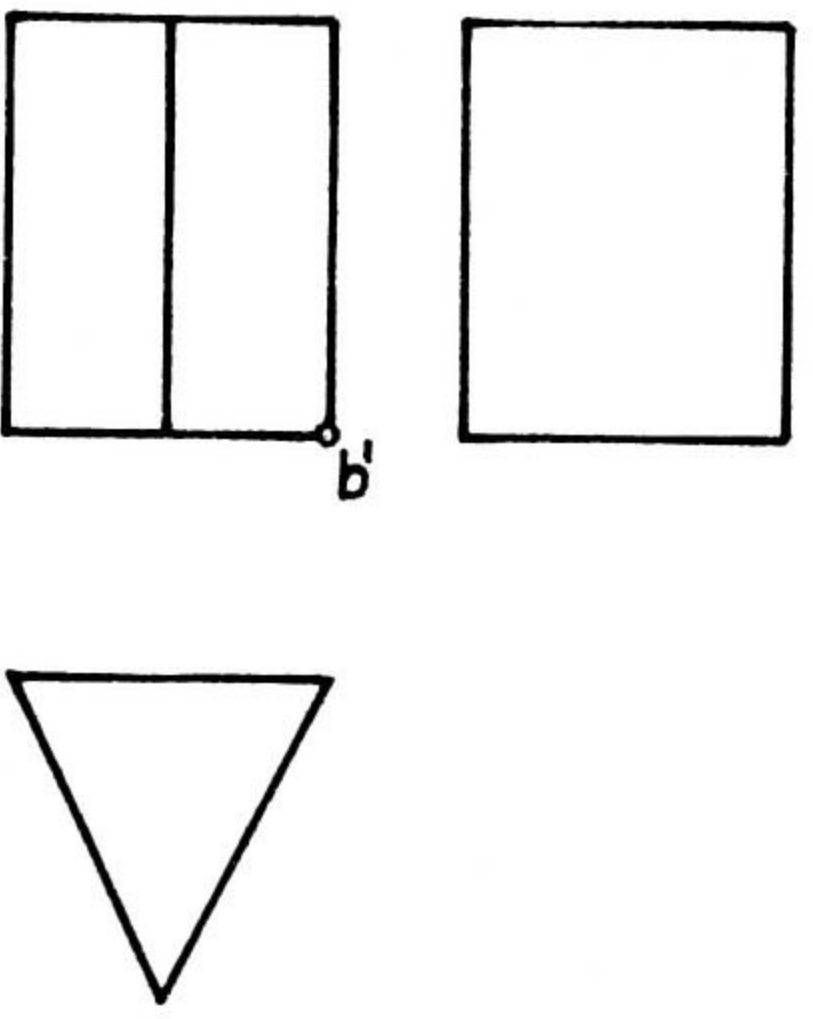
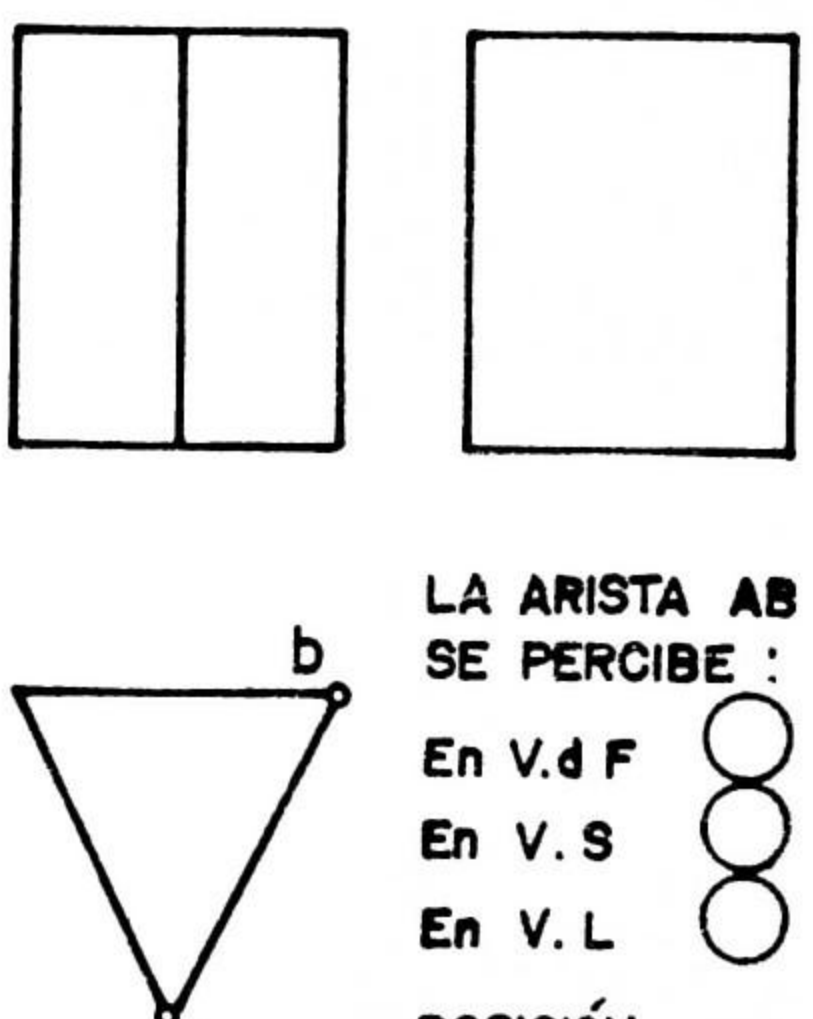
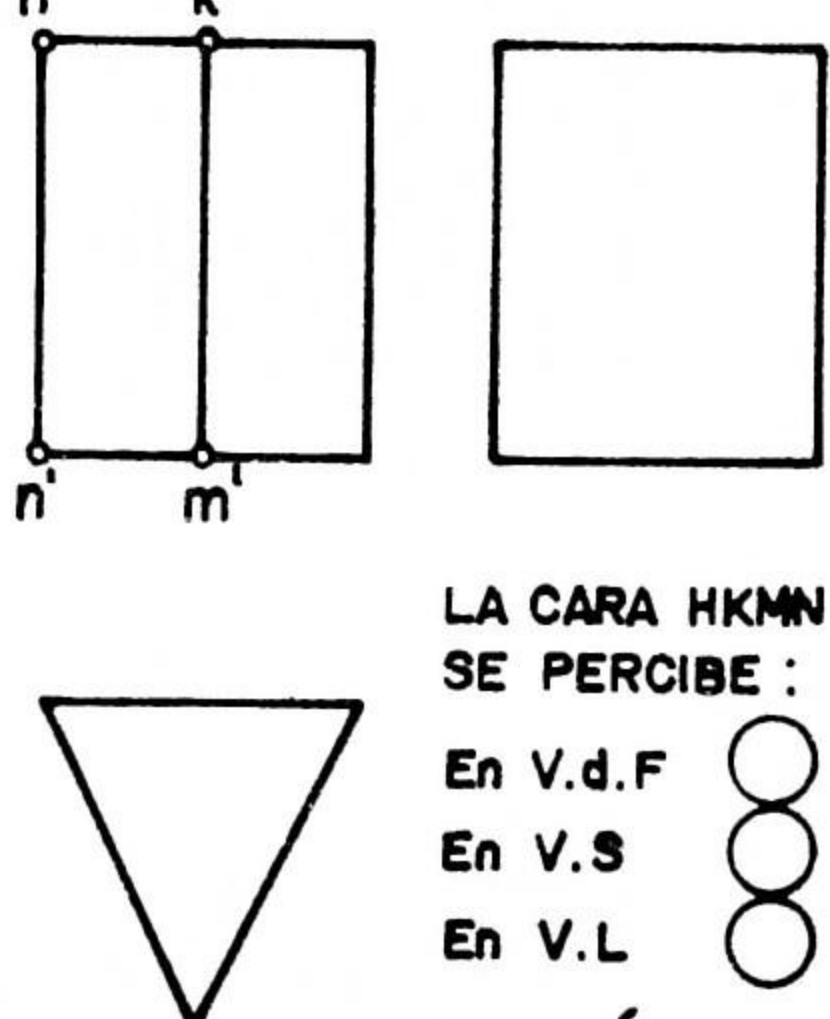
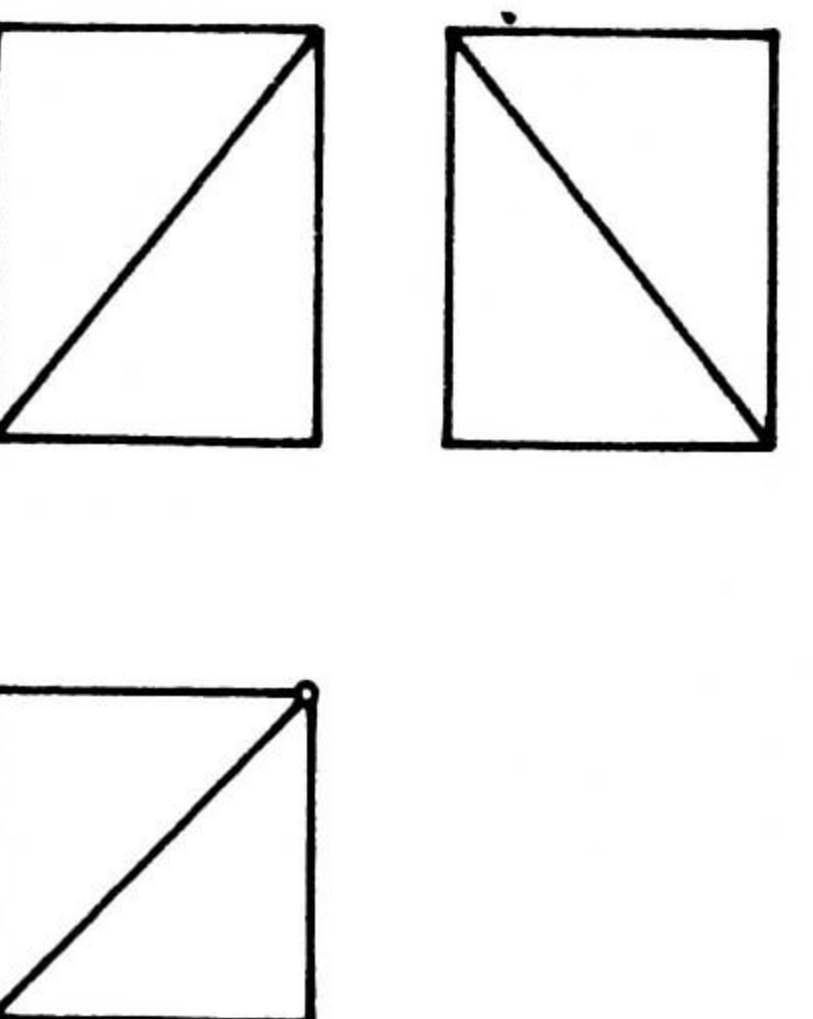
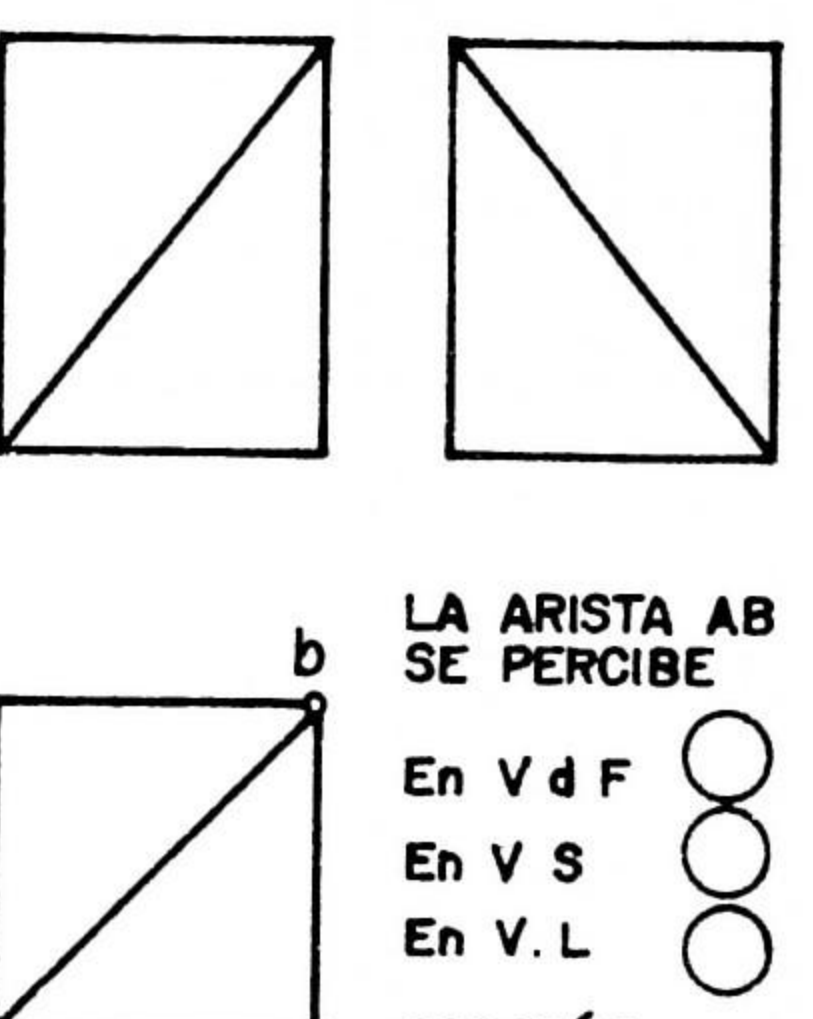
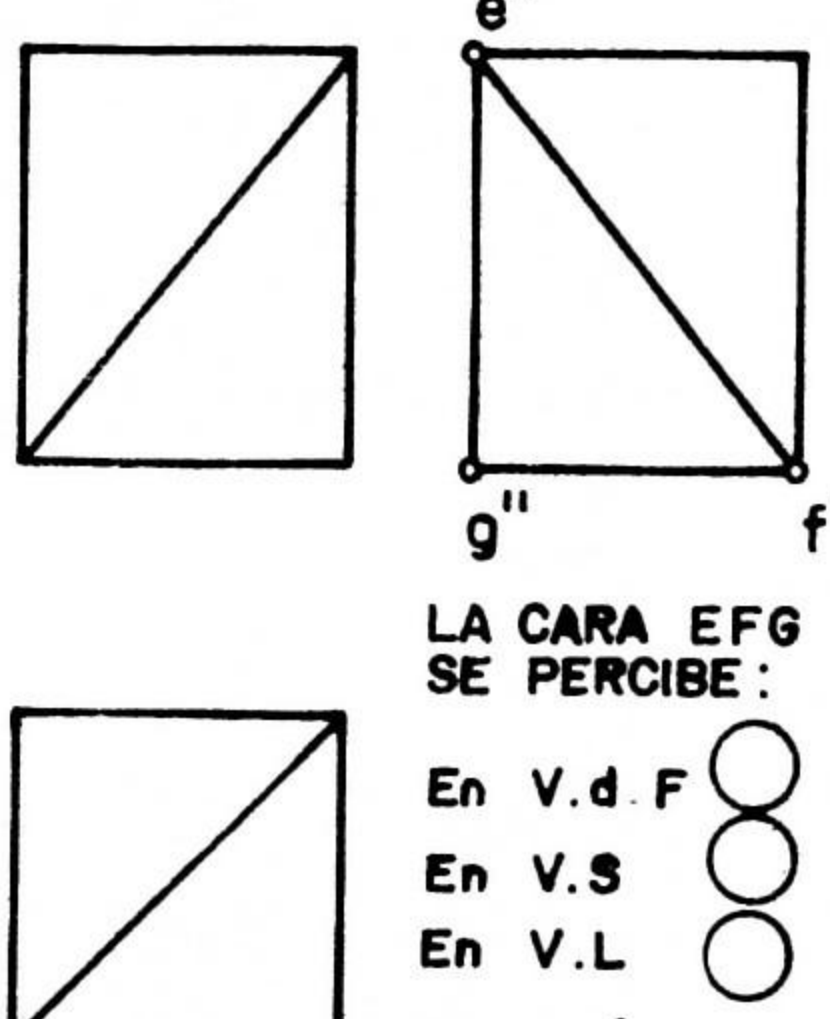
VÉRTICES	ARISTAS	CARAS
	 <p>LA ARISTA AB SE PERCIBE:</p> <p>En V.d.F <input type="radio"/></p> <p>En V.S <input type="radio"/></p> <p>En V.L <input type="radio"/></p> <p>POSICIÓN BÁSICA: <input type="checkbox"/></p>	 <p>LA CARA MNK SE PERCIBE:</p> <p>En V.d.F <input type="radio"/></p> <p>En V.S <input type="radio"/></p> <p>En V.L <input type="radio"/></p> <p>POSICIÓN BÁSICA: <input type="checkbox"/></p>
	 <p>LA ARISTA AB SE PERCIBE:</p> <p>En V.d.F <input type="radio"/></p> <p>En V.S <input type="radio"/></p> <p>En V.L <input type="radio"/></p> <p>POSICIÓN BÁSICA: <input type="checkbox"/></p>	 <p>LA CARA HKMN SE PERCIBE:</p> <p>En V.d.F <input type="radio"/></p> <p>En V.S <input type="radio"/></p> <p>En V.L <input type="radio"/></p> <p>POSICIÓN BÁSICA: <input type="checkbox"/></p>
	 <p>LA ARISTA AB SE PERCIBE:</p> <p>En V.d.F <input type="radio"/></p> <p>En V.S <input type="radio"/></p> <p>En V.L <input type="radio"/></p> <p>POSICIÓN BÁSICA: <input type="checkbox"/></p>	 <p>LA CARA EFG SE PERCIBE:</p> <p>En V.d.F <input type="radio"/></p> <p>En V.S <input type="radio"/></p> <p>En V.L <input type="radio"/></p> <p>POSICIÓN BÁSICA: <input type="checkbox"/></p>

DPTO. DISEÑO BASICO		ISPJAE FACULTAD DE ARQUITECTURA		D D D
ASIGNATURA	TEMA			
DOC.	ALUM.	No.	GRUPO.	
FECHA		EVAL.		

5.4.2-5.4.3 REPRESENTACION E INTERPRETACION

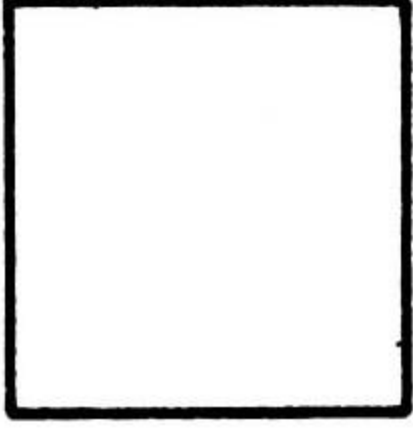
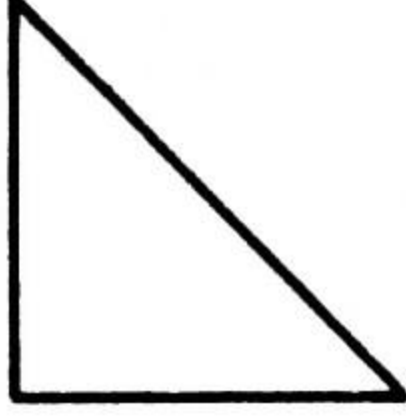
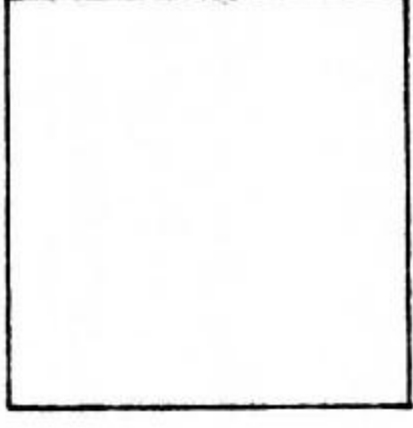
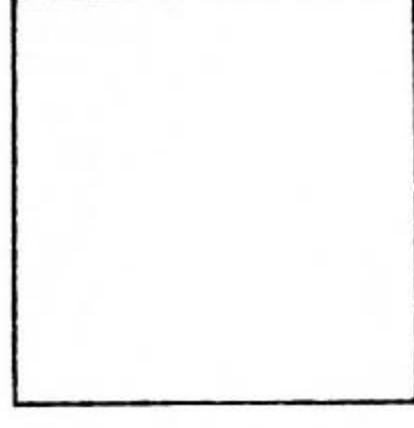
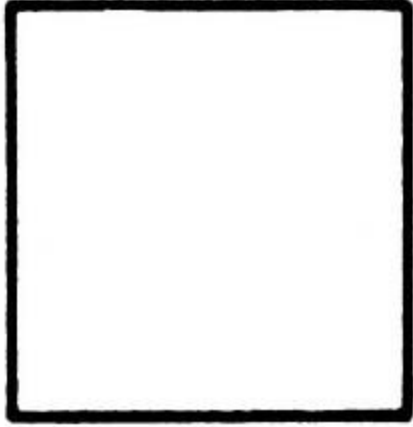
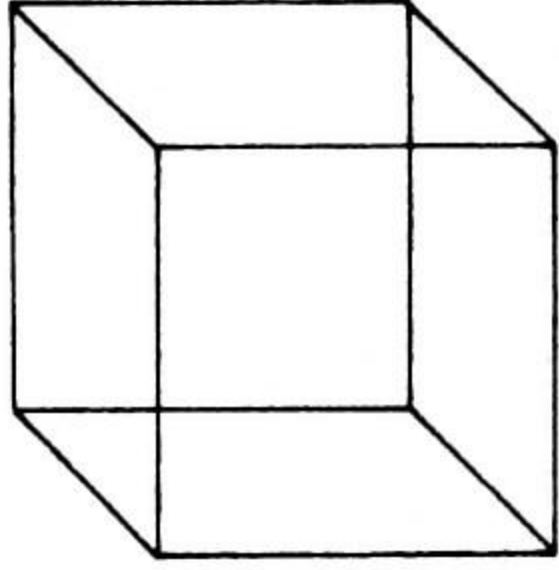
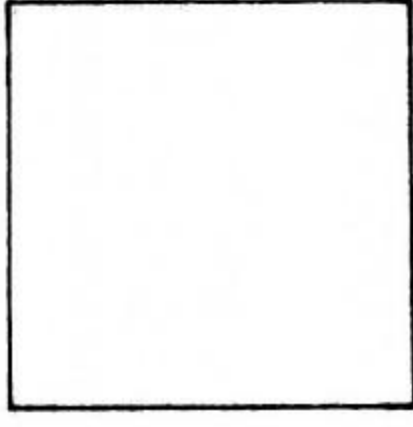
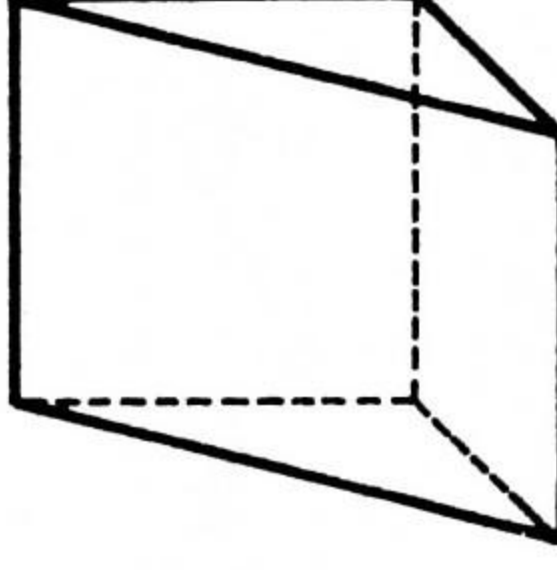
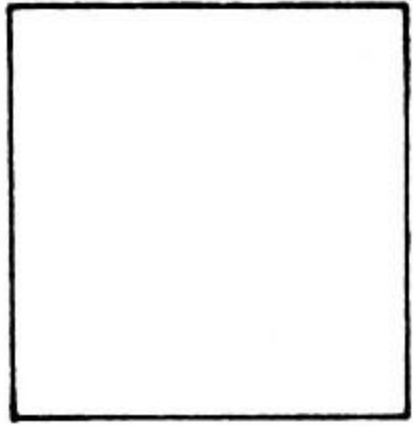
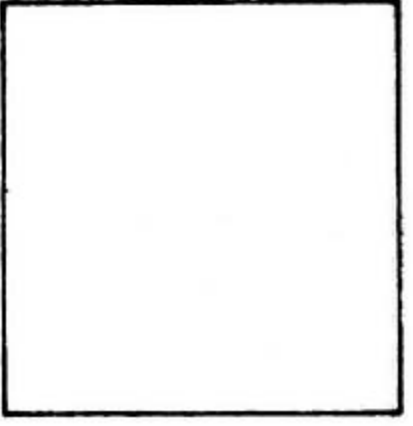
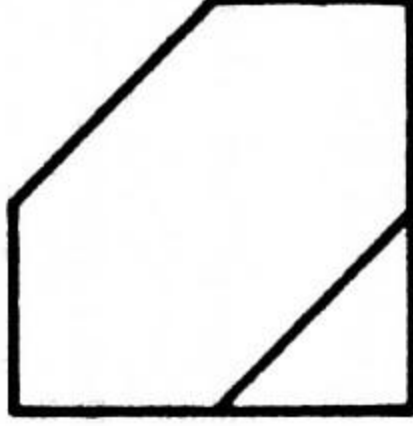
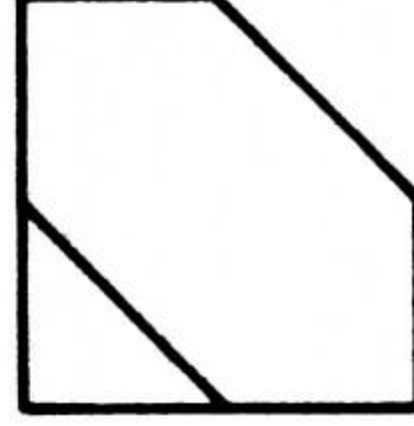
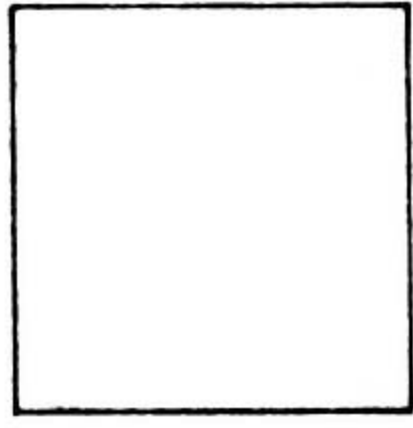
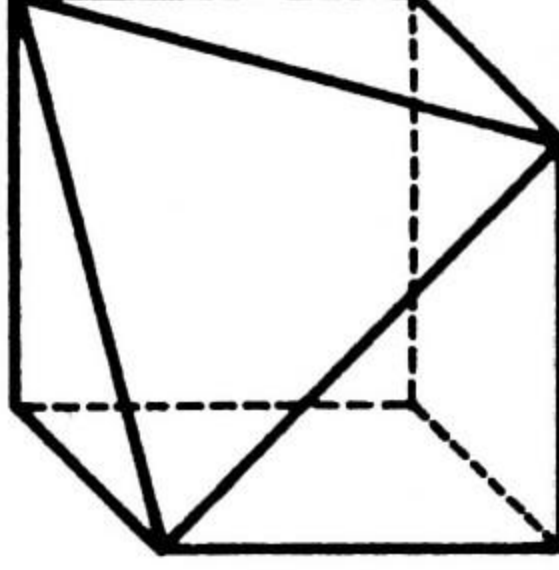
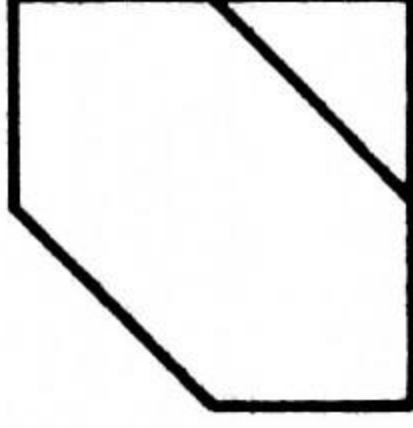
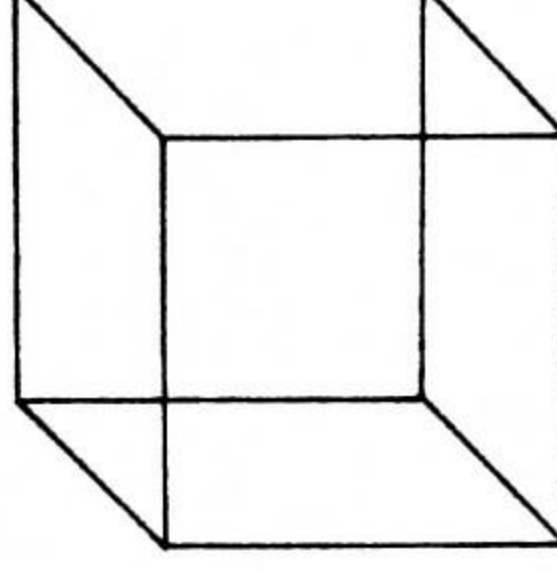
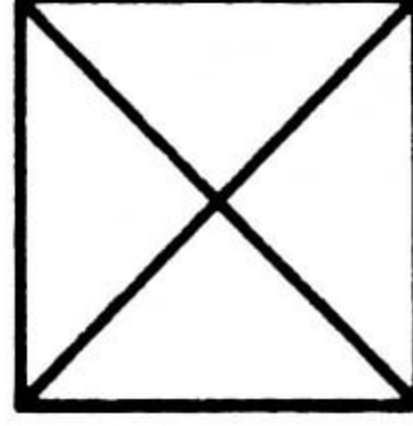
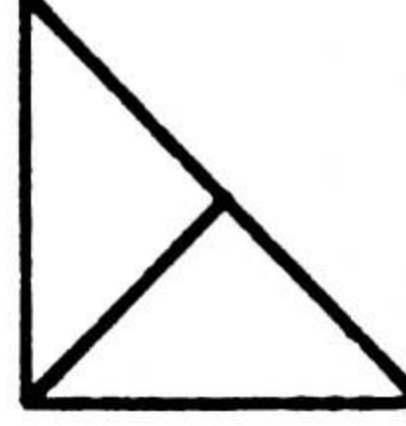
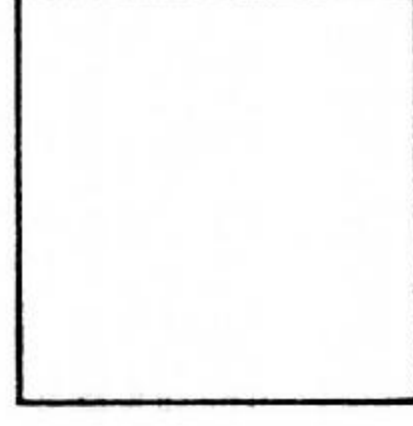
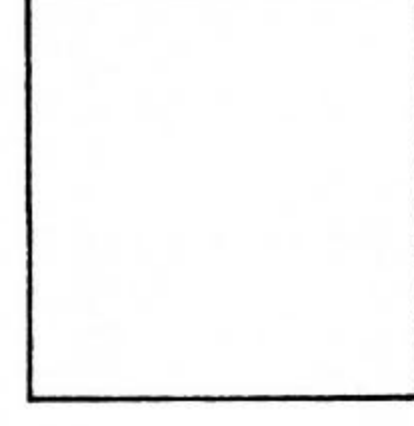
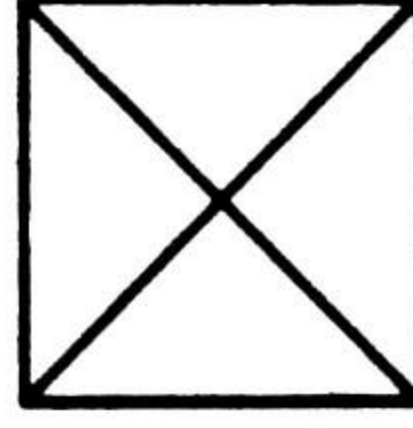
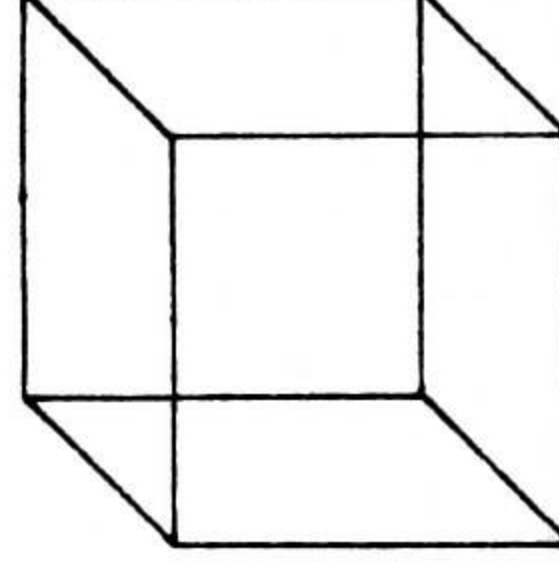
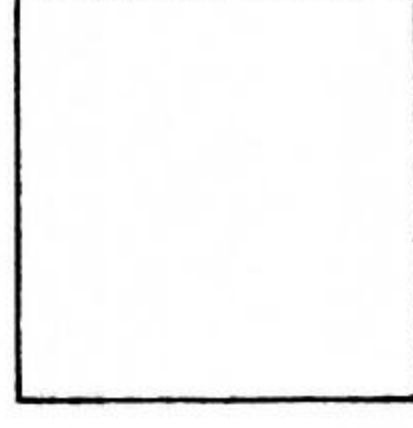
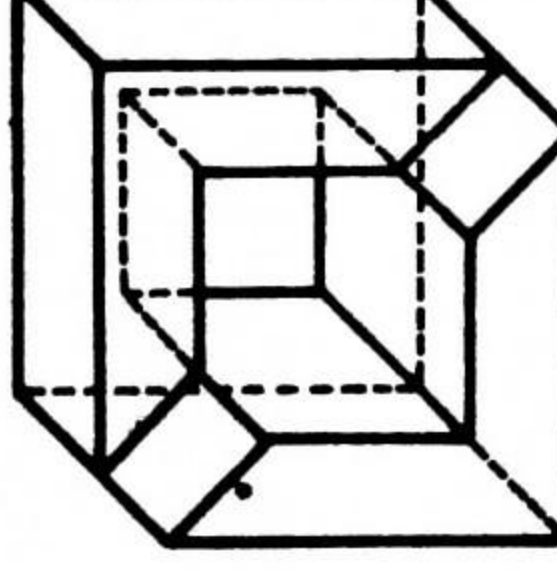
DPTO. DISEÑO BASICO

ISPJAE FACULTAD DE ARQUITECTURA

ASIGNATURA	TEMA		
DOC.	ALUM.	No.	OPC.
FECHA		EVAL.	

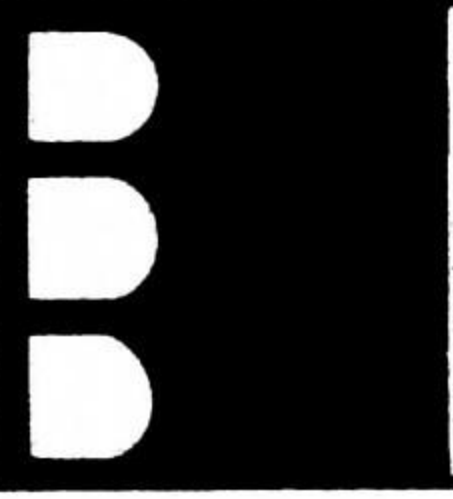

5.4.3 INTERPRETACION EN PERSPECTIVA CABALLERA

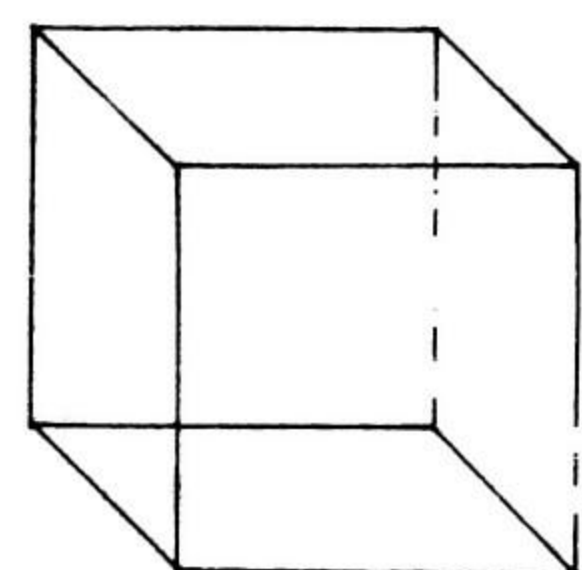
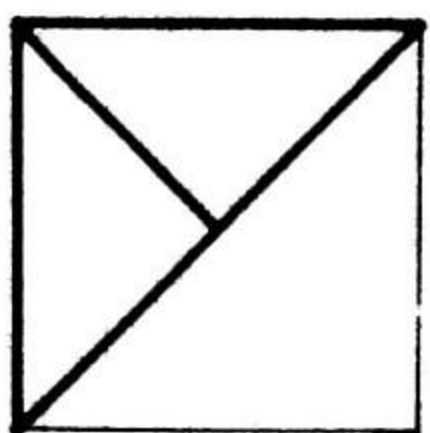
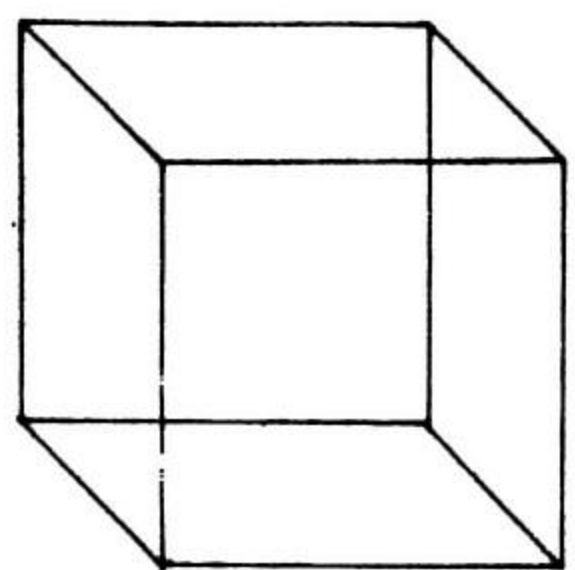
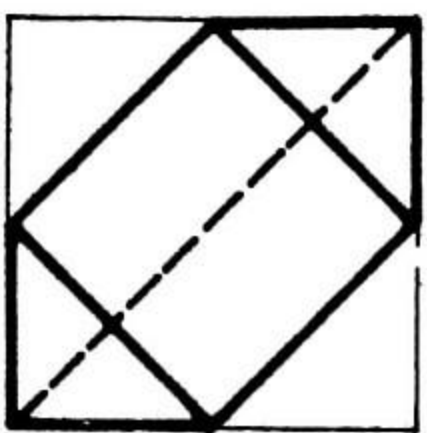
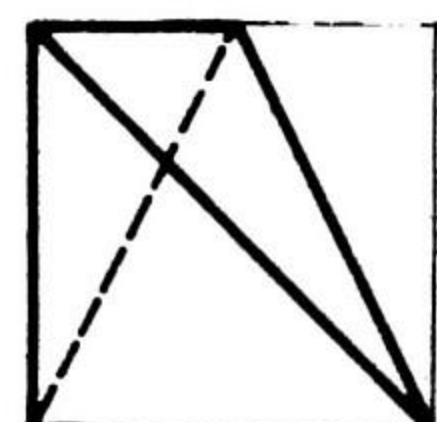
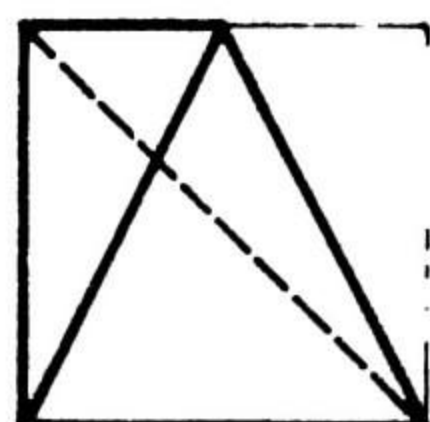
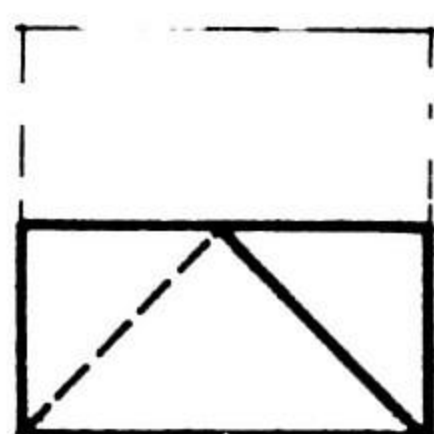
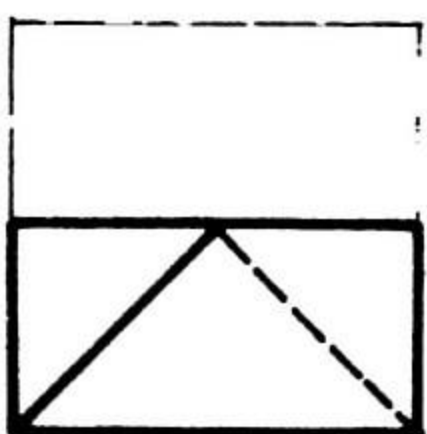
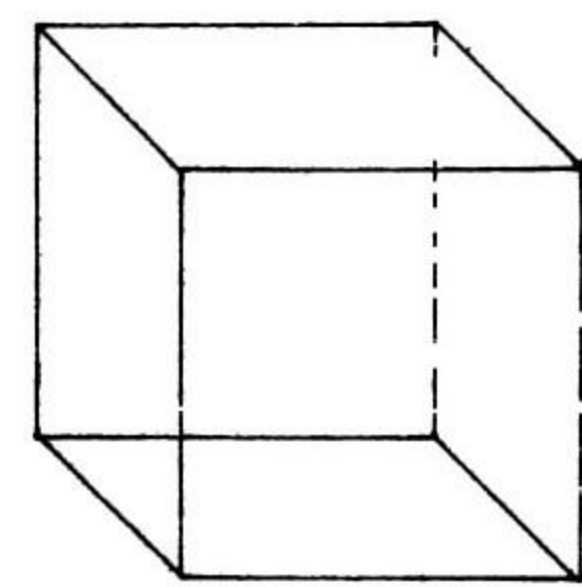
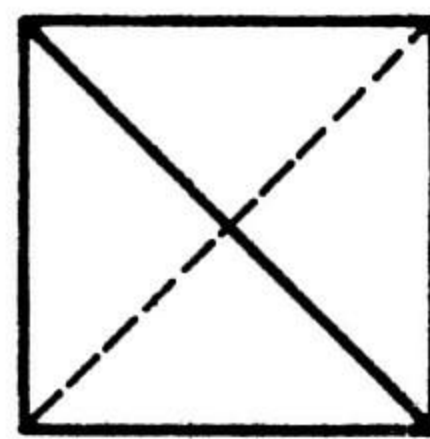
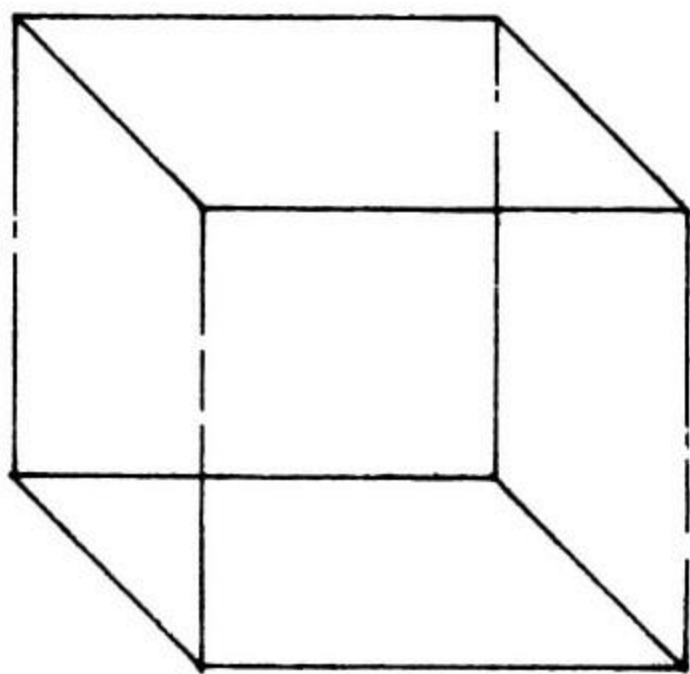
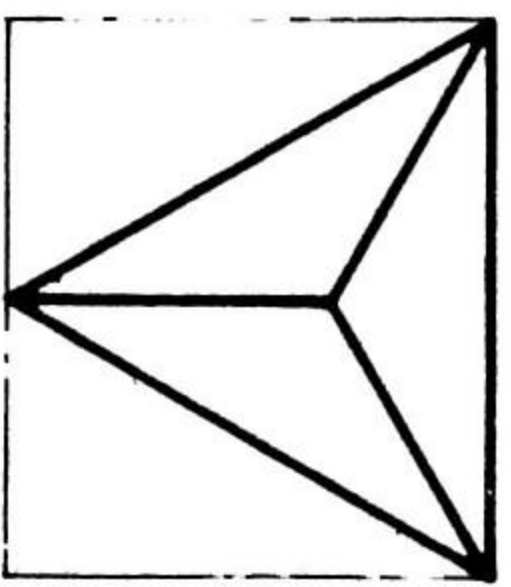
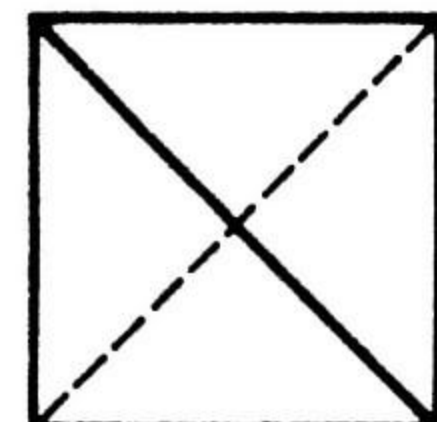
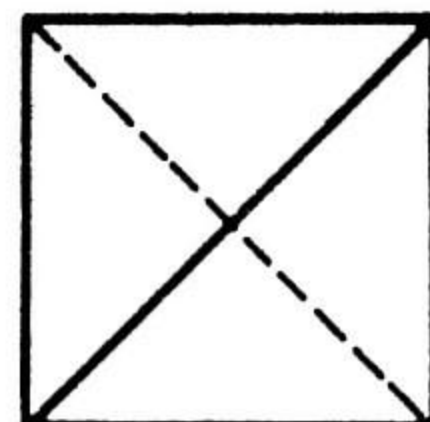
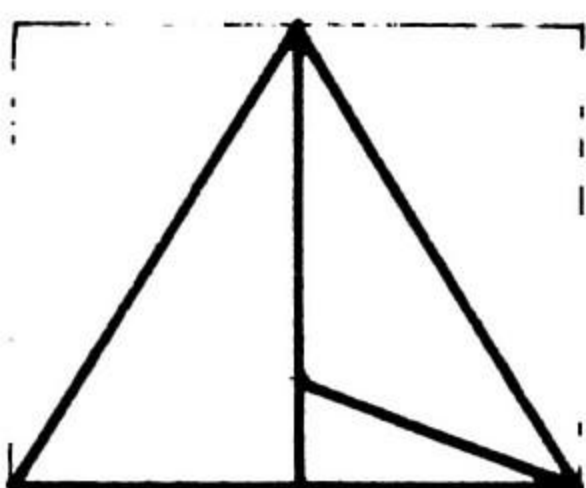
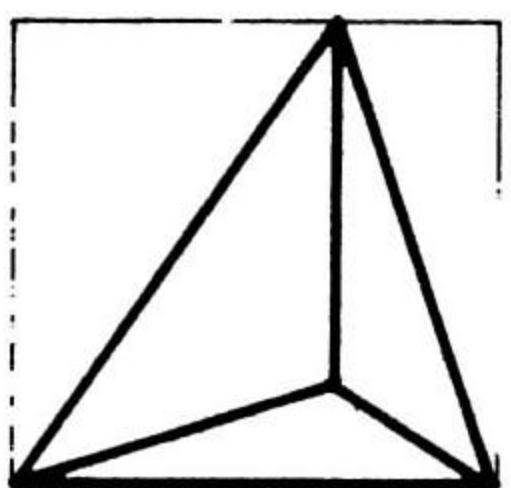
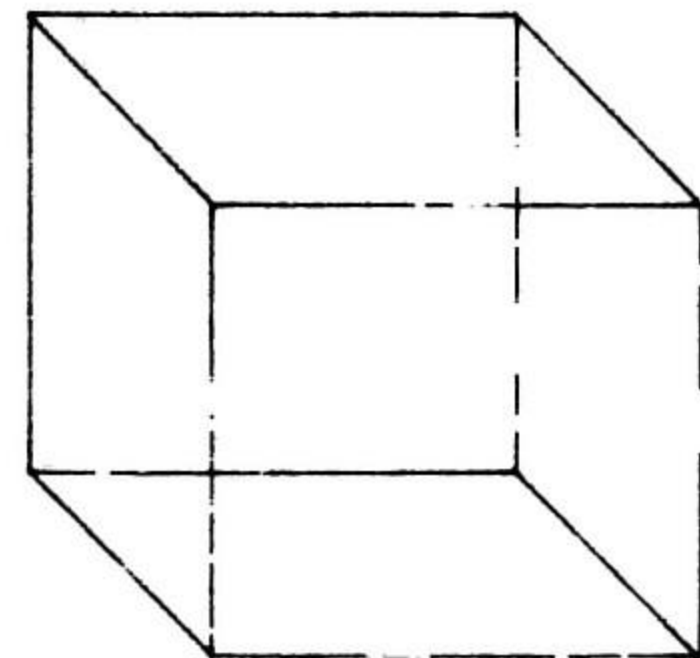
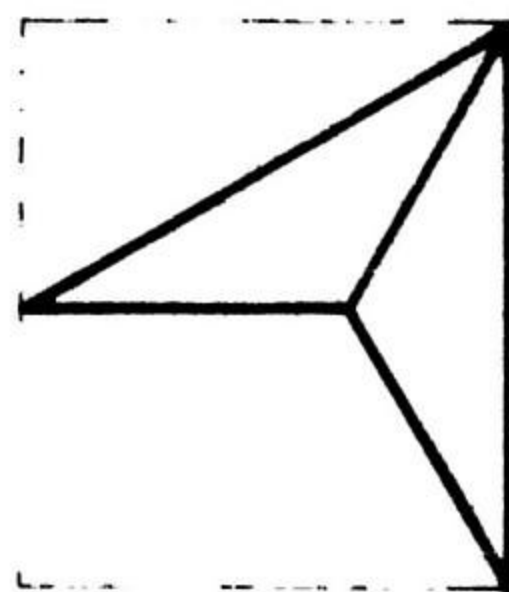
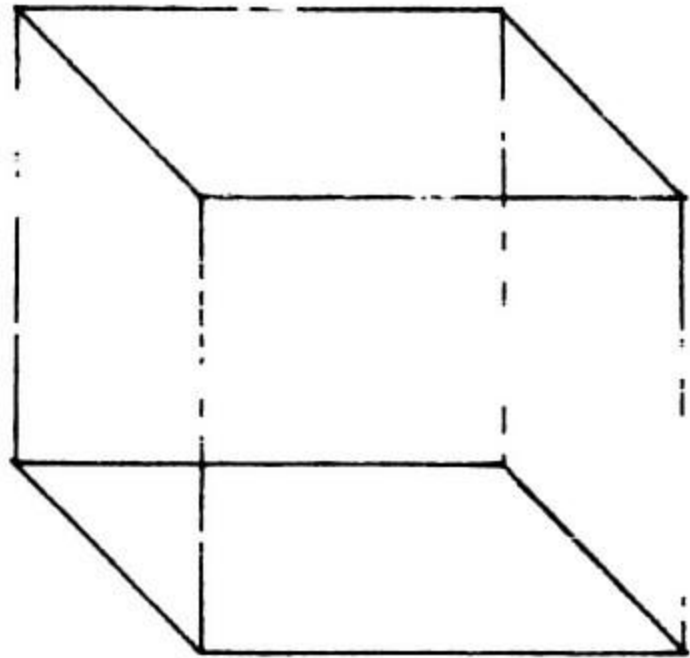
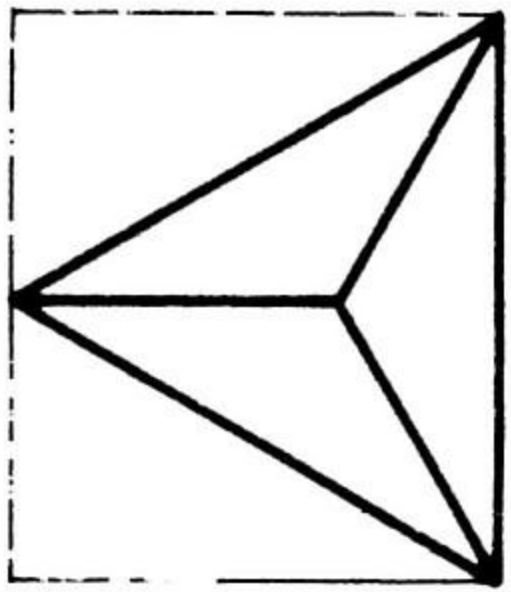
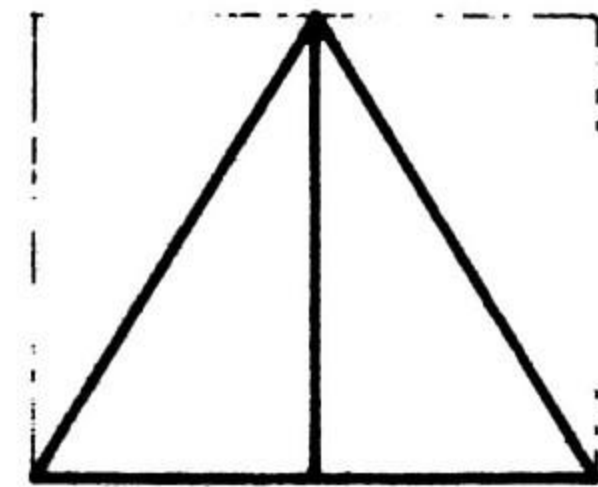
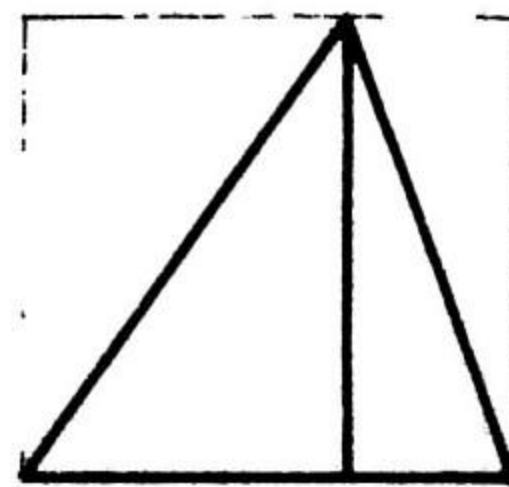
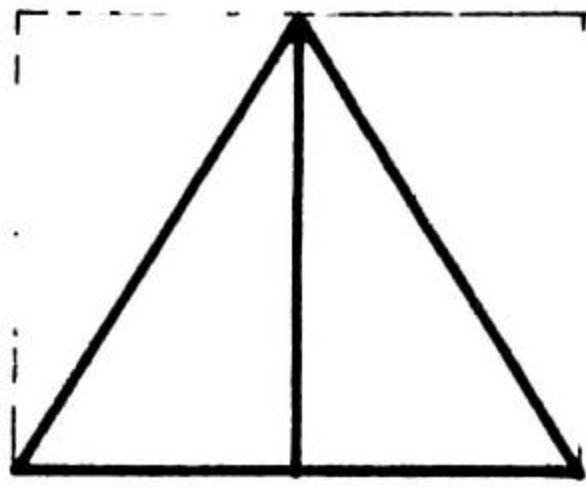
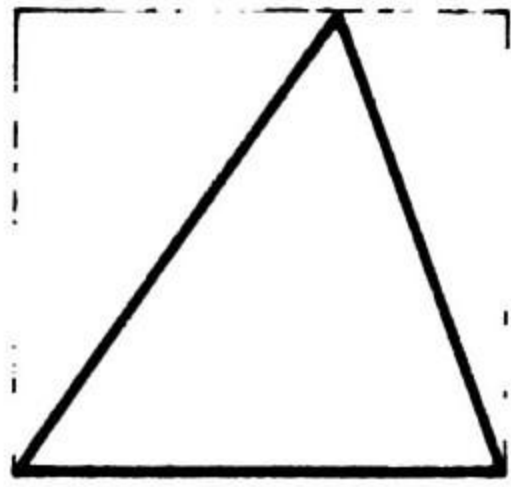

DPTO. DISEÑO BASICO

ISPJAE FACULTAD DE ARQUITECTURA

ASIGNATURA

TEMA

DOC.

ALUM.

No.

GPO.

FECHA

EVAL.

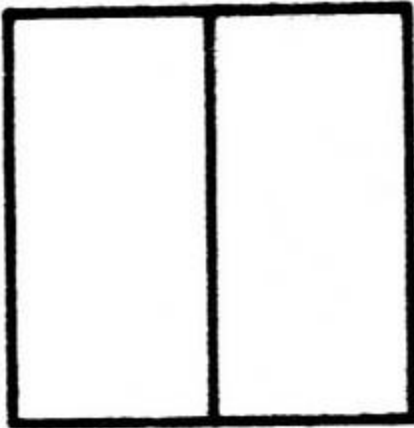
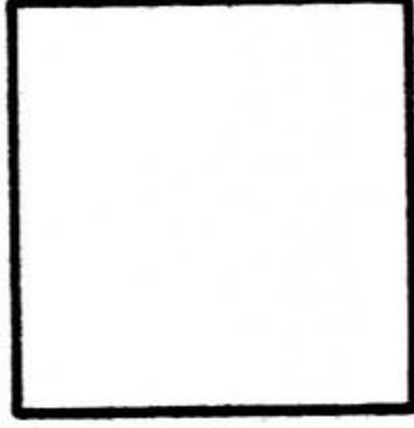
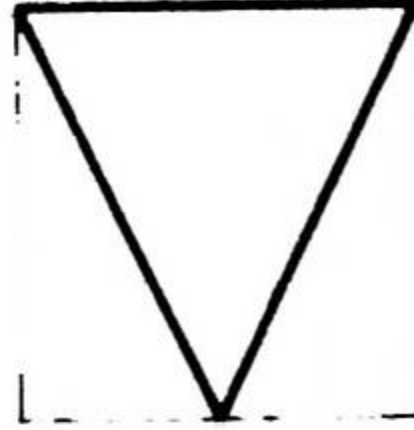
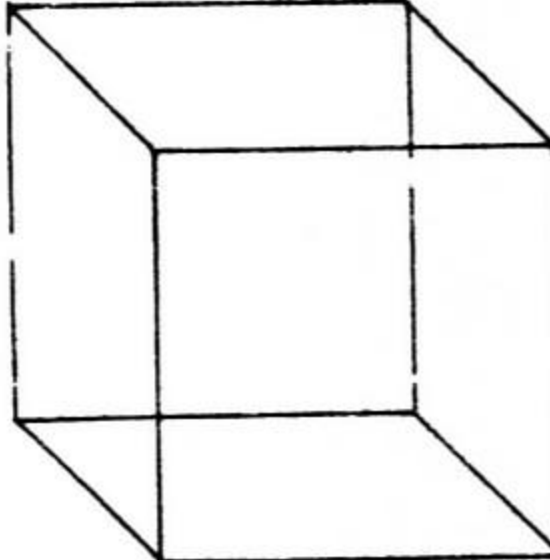
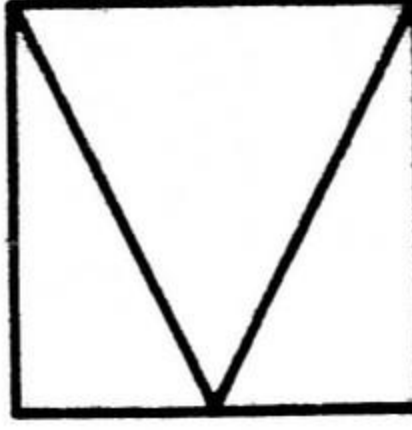
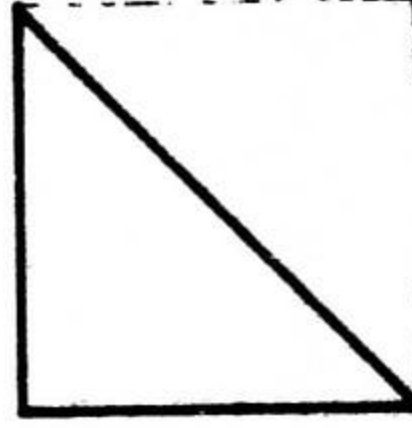
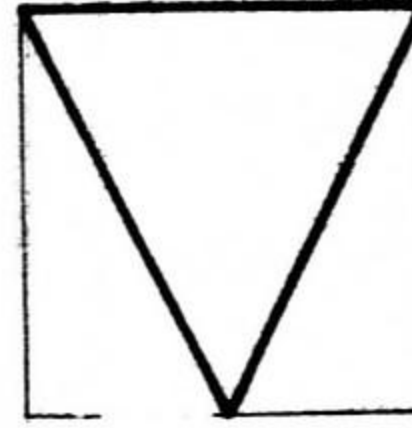
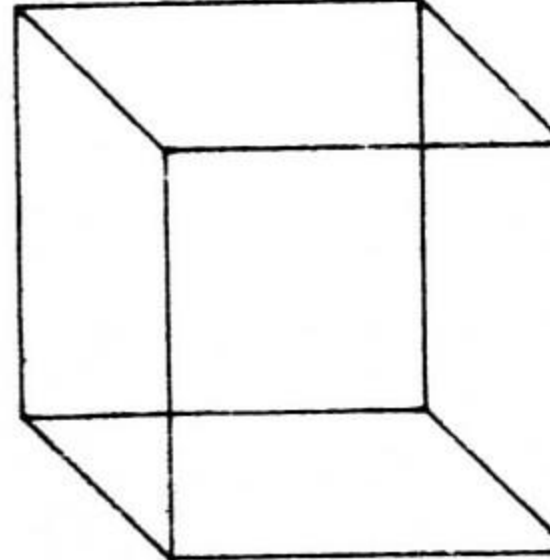
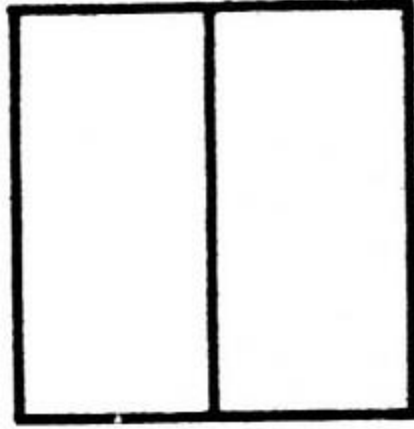
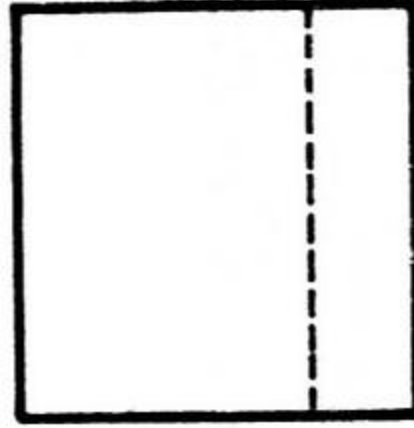
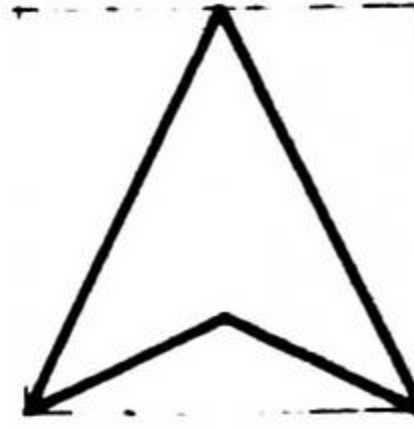
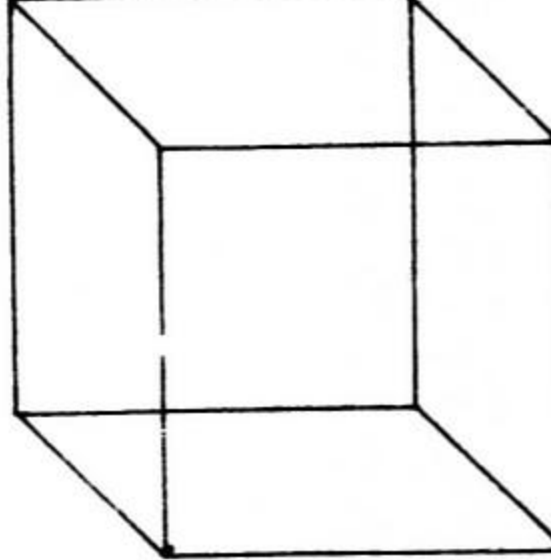
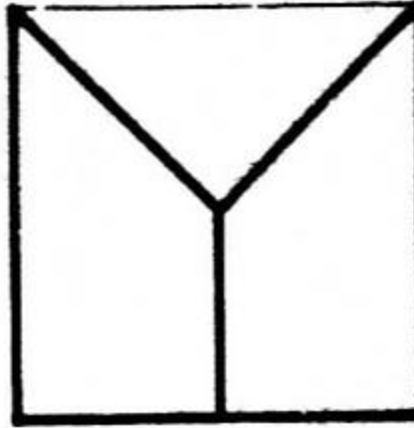
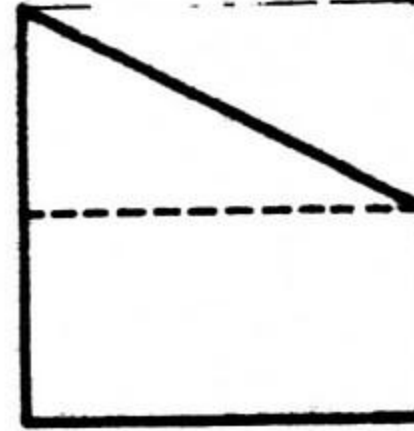
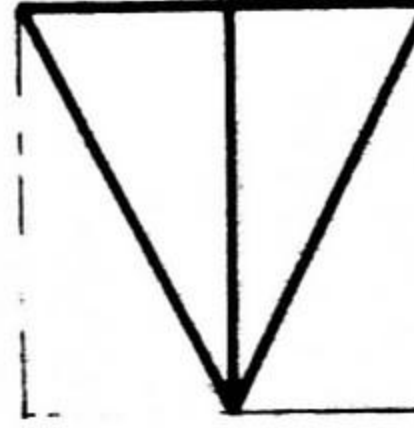
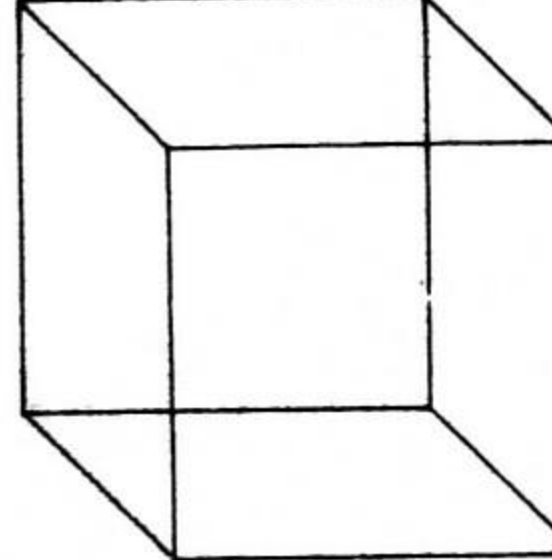
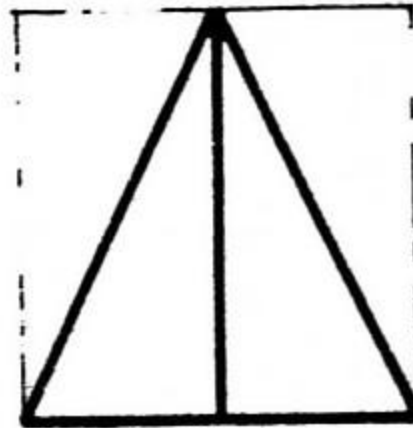
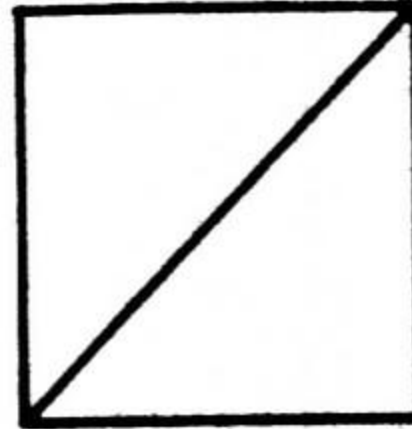
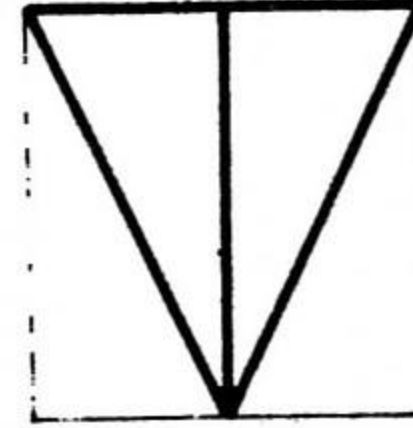
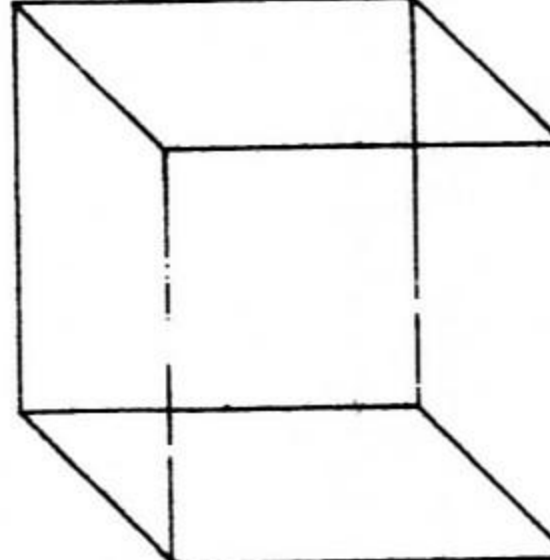
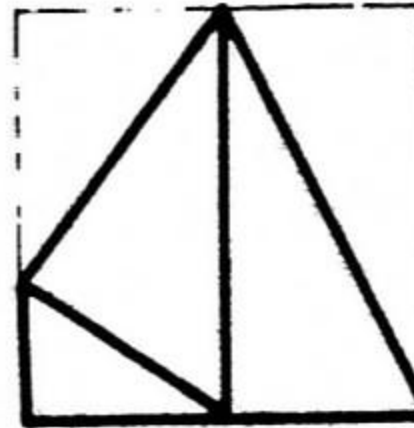
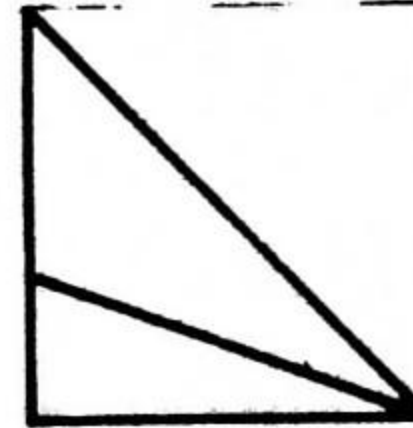
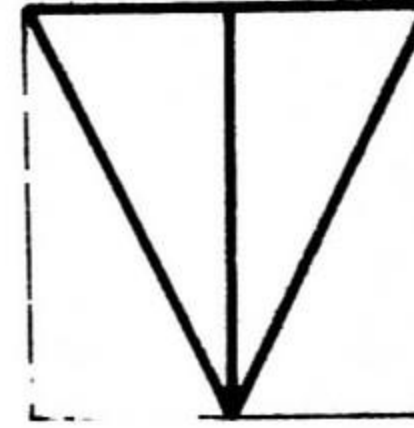
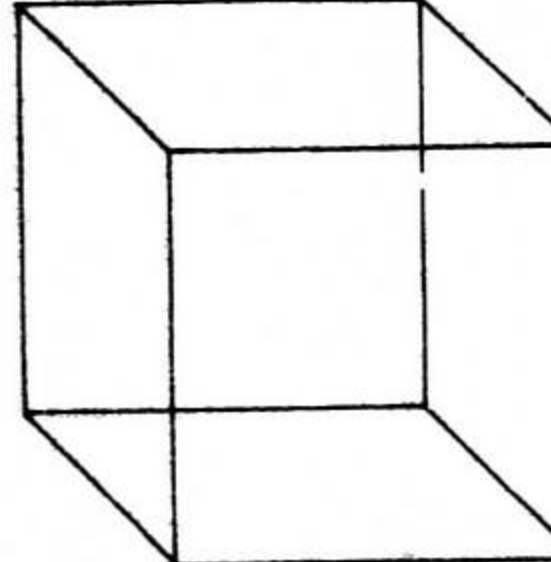

5.4.3 INTERPRETACION EN PERSPECTIVA CABALLERA

DPTO. DISEÑO BASICO		ISPJAE		D D D
		FACULTAD DE ARQUITECTURA		
ASIGNATURA	TEMA	No.	GRUPO.	
DOC.	ALUM.	EVAL.		
FECHA				

5.4.3 INTERPRETACION EN PERSPECTIVA CABALLERA

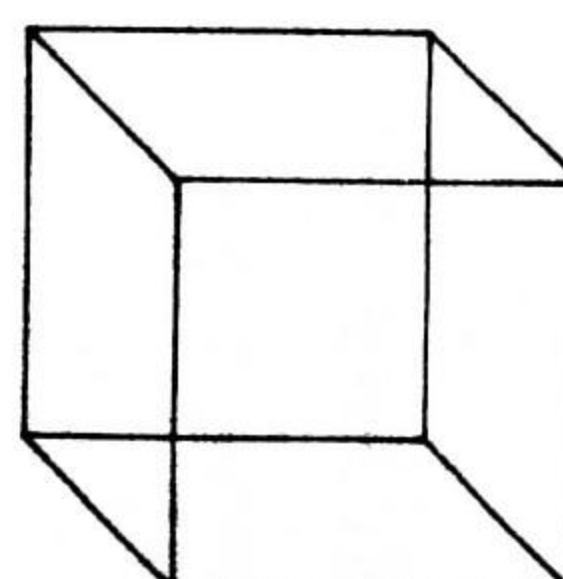
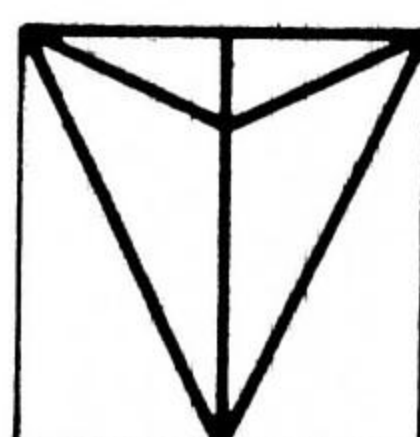
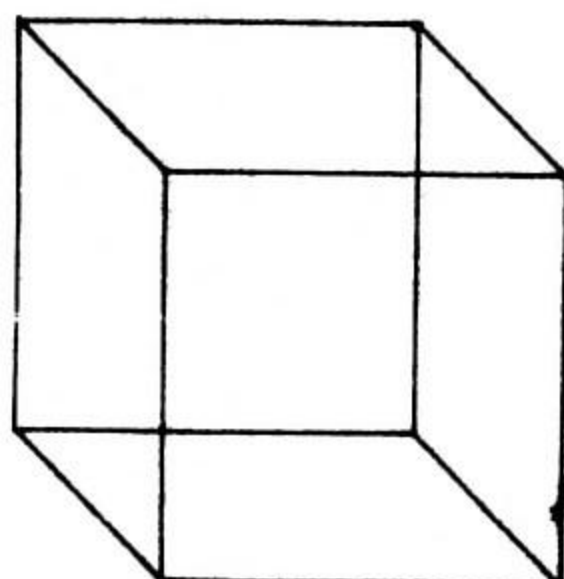
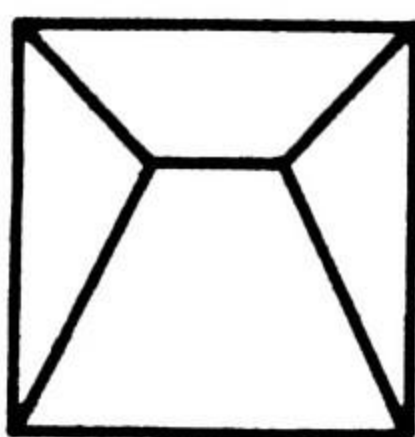
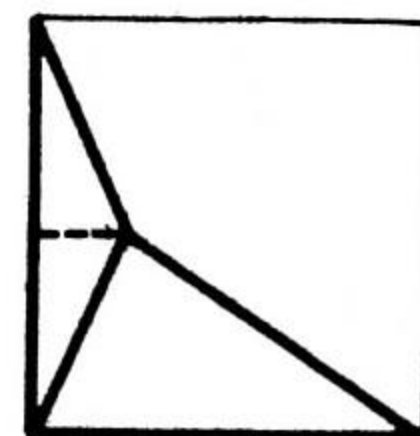
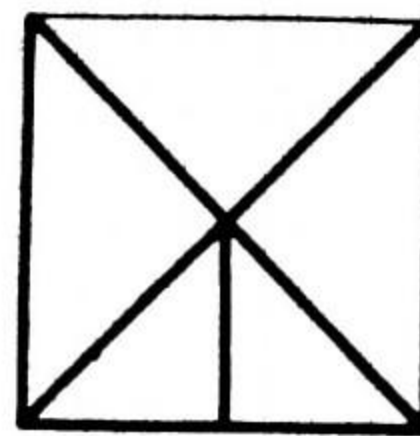
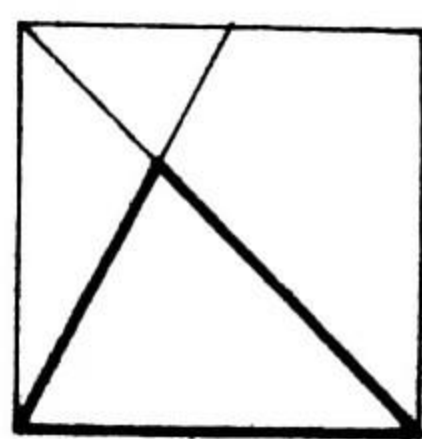
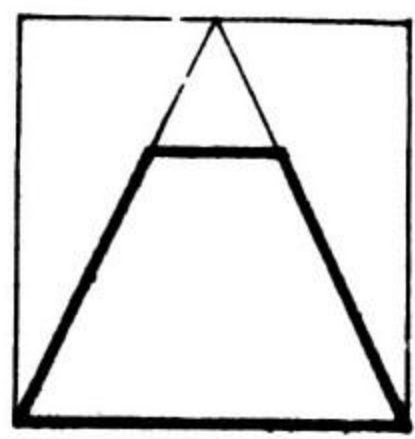
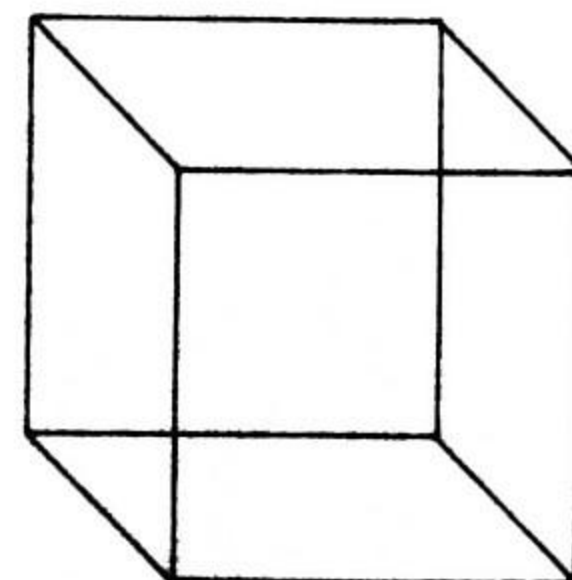
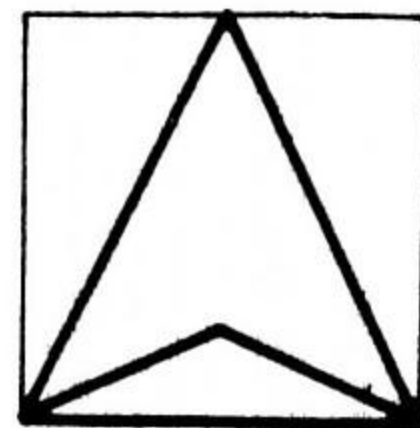
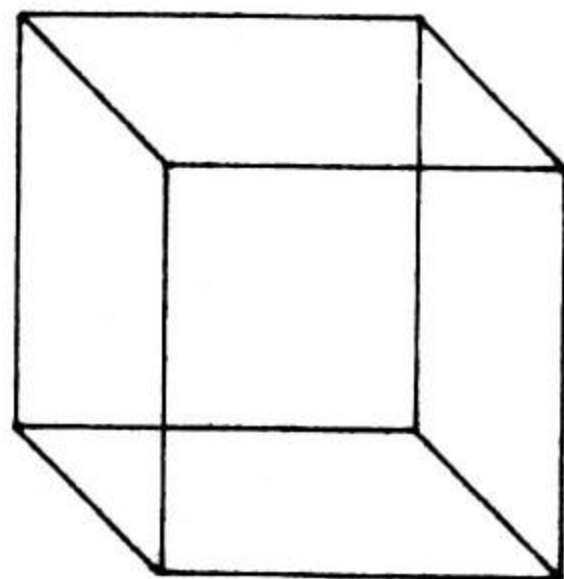
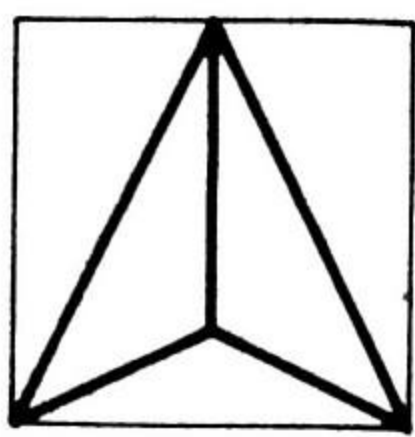
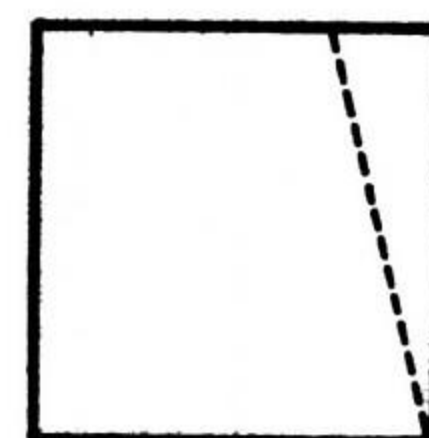
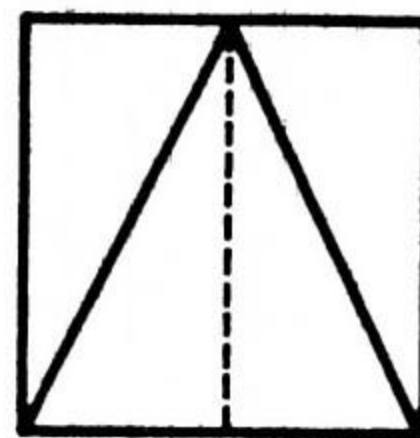
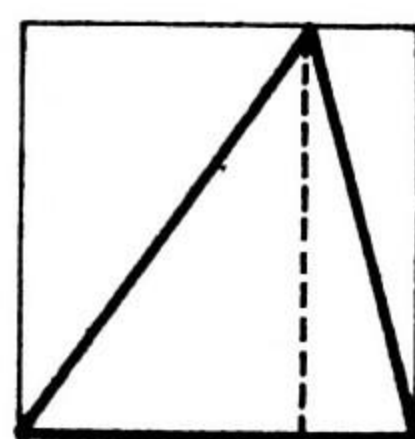
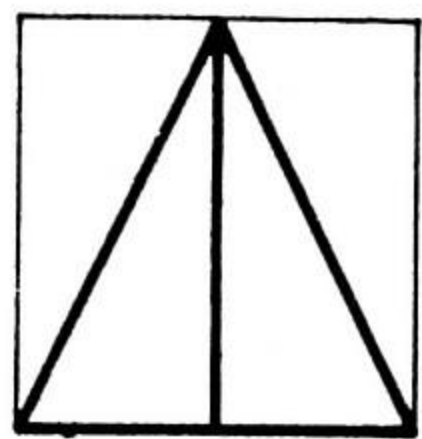
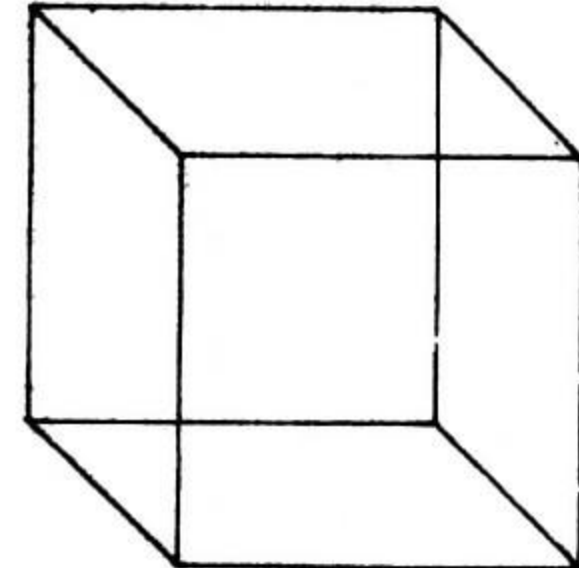
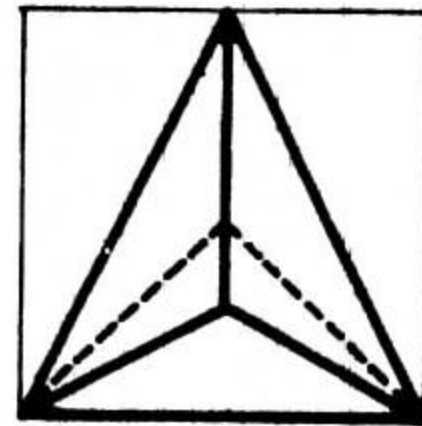
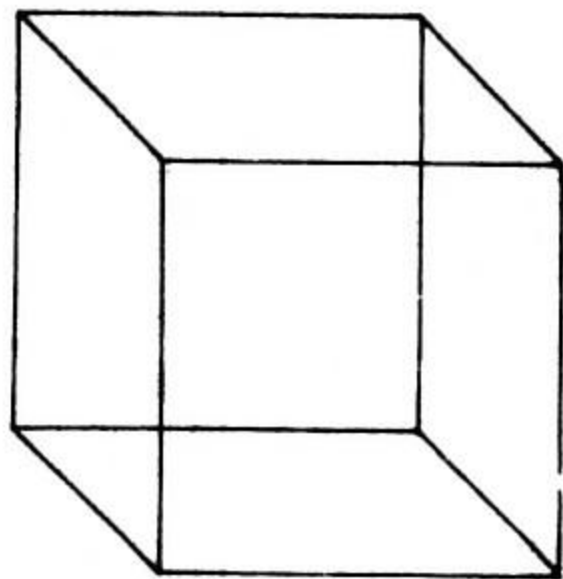
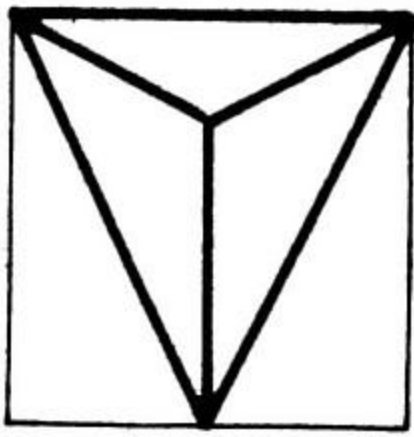
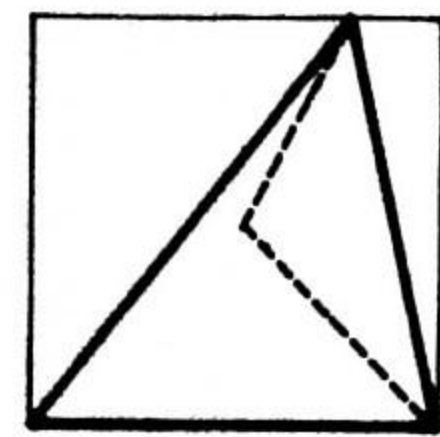
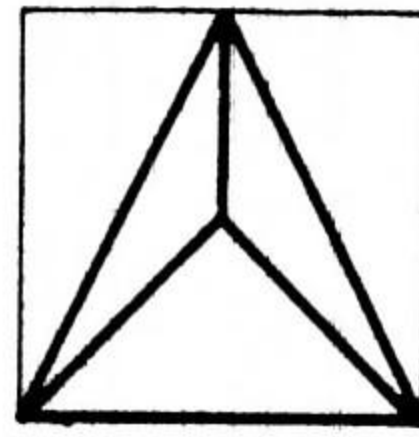
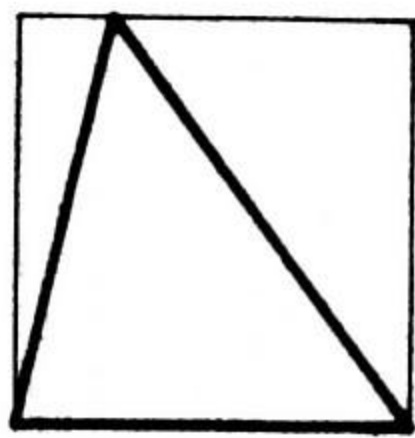
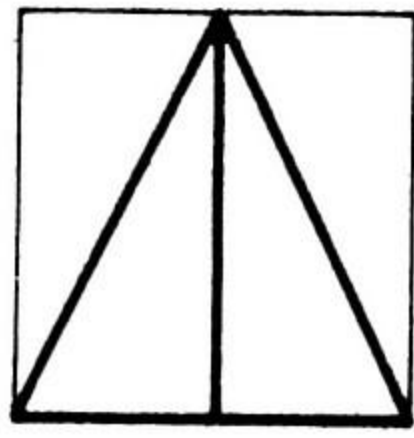

DPTO. DISEÑO BASICO

ISPJAE FACULTAD DE ARQUITECTURA

ASIGNATURA

TEMA

DOC.

ALUM.

No.

SPO.

FECHA

EVAL.



5.4.3 INTERPRETAR Y DIBUJAR VISTA DE FRENTE E ISOMETRICO

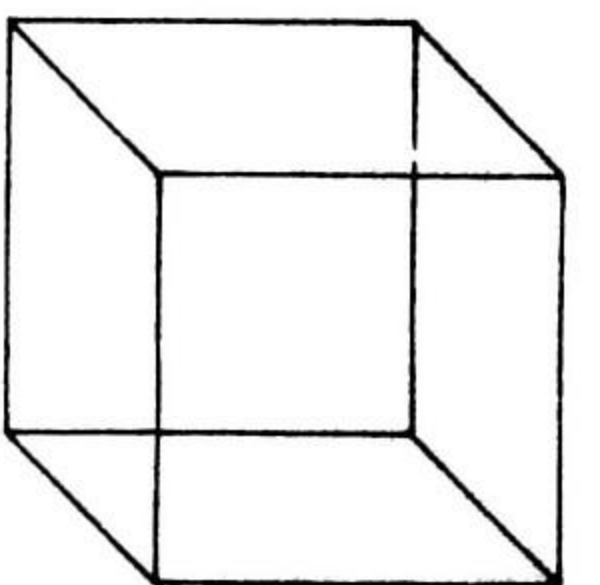
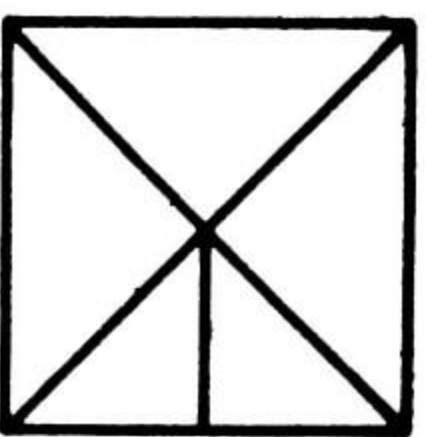
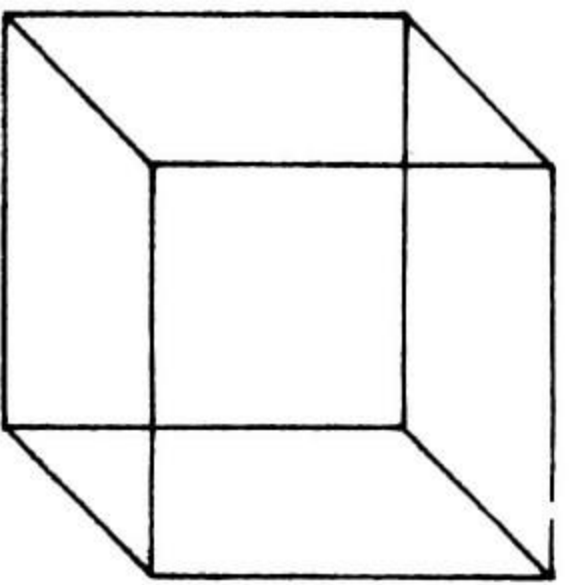
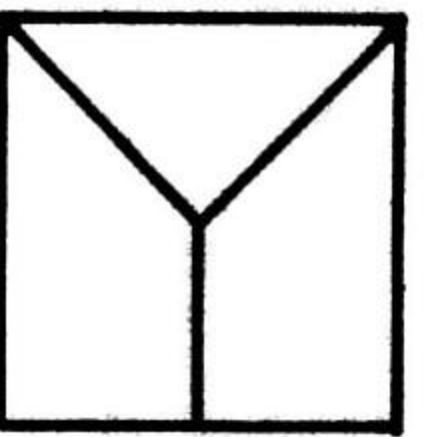
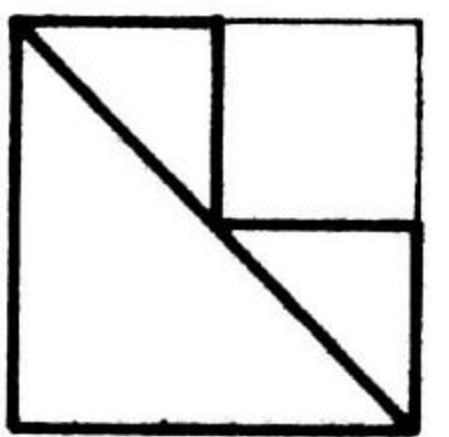
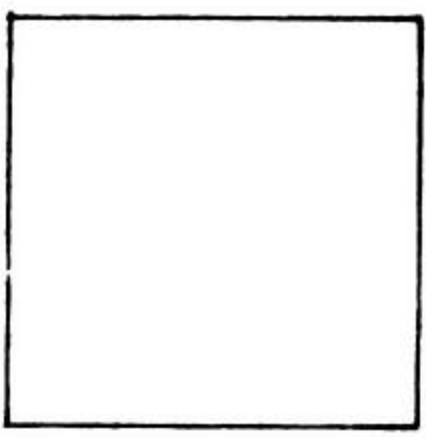
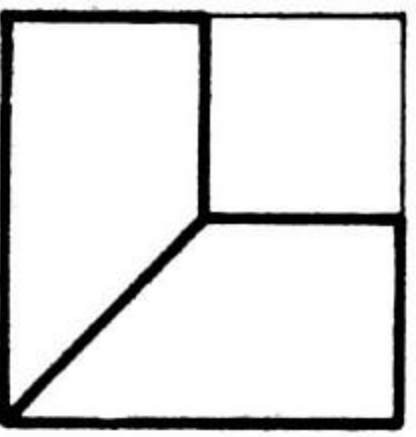
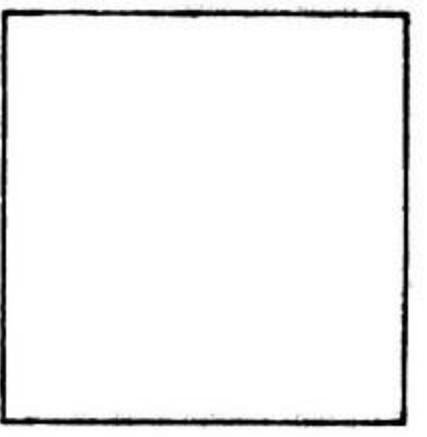
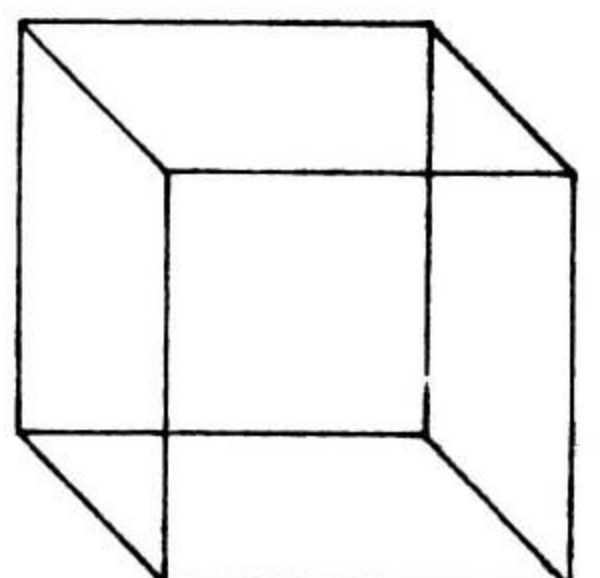
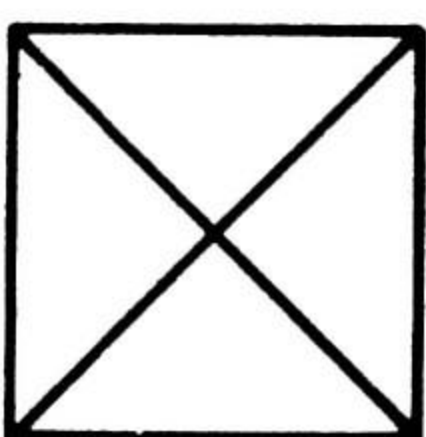
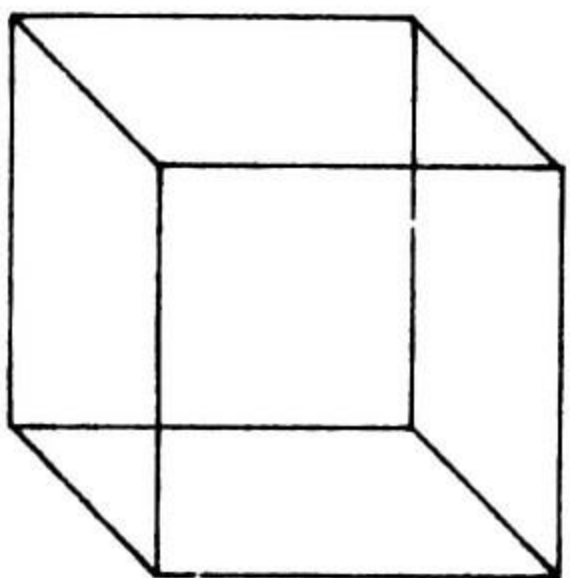
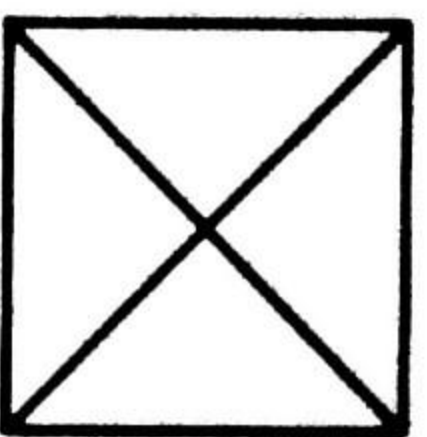
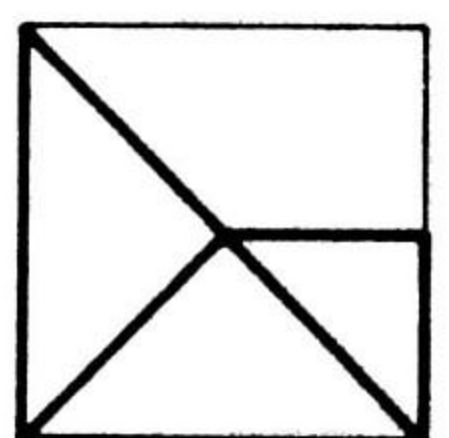
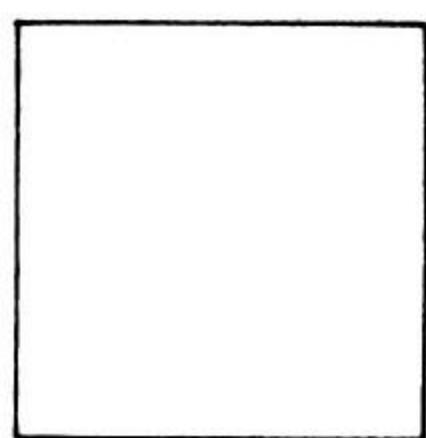
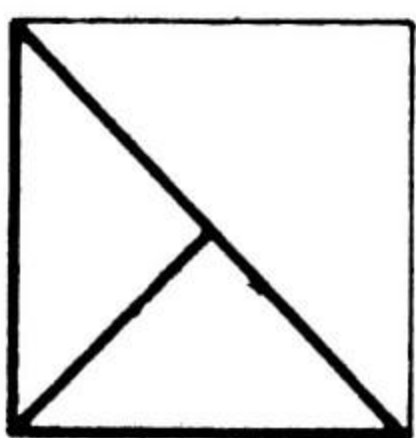
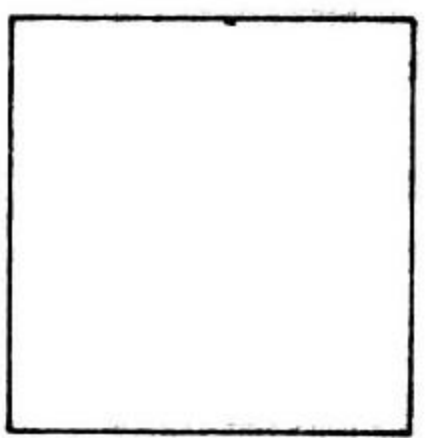
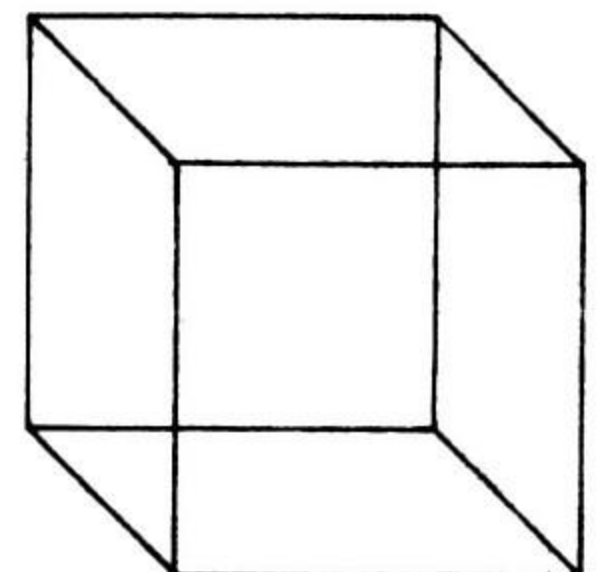
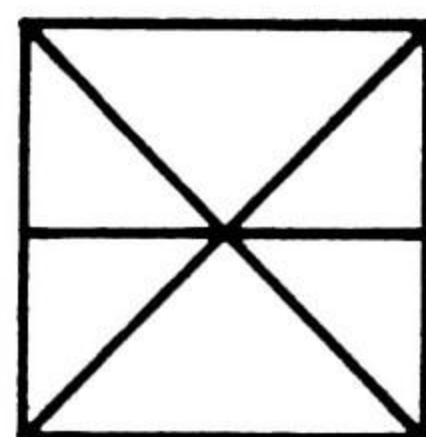
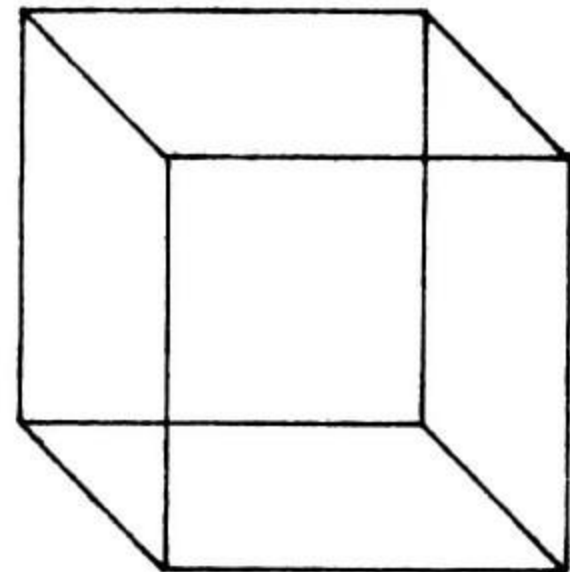
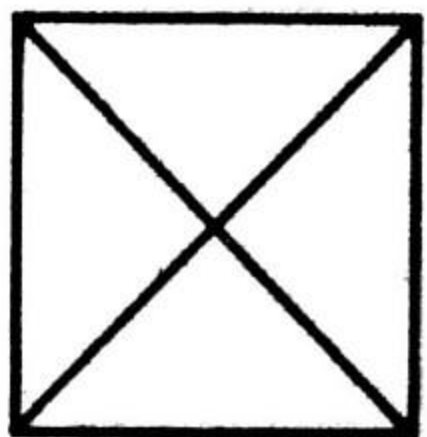
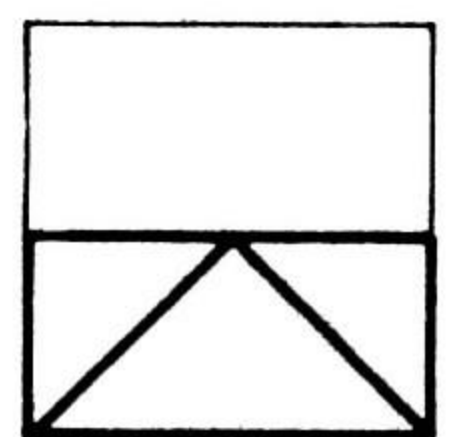
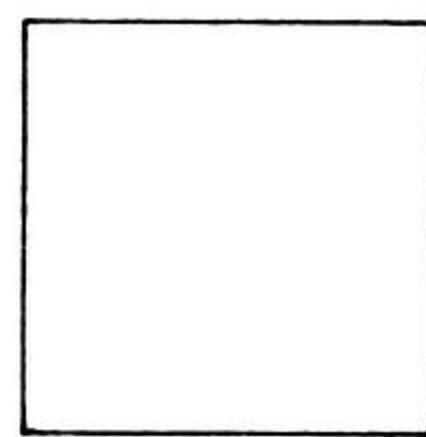
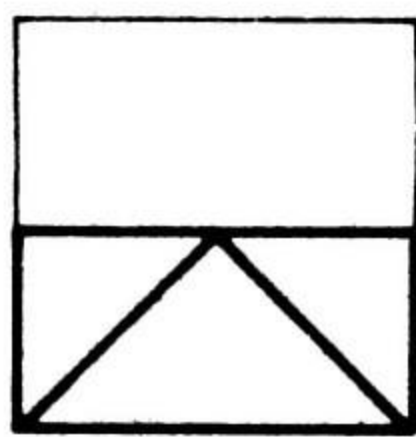
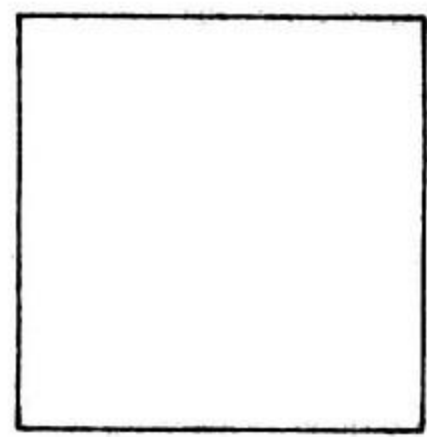

DPTO. DISEÑO BASICO

ISPJAE FACULTAD DE ARQUITECTURA

ASIGNATURA

TEMA

DOC.

ALUM.

No.

GRUPO.

FECHA

EVAL.



5.4.3 INTERPRETACION EN PERSPECTIVA CABALLERA

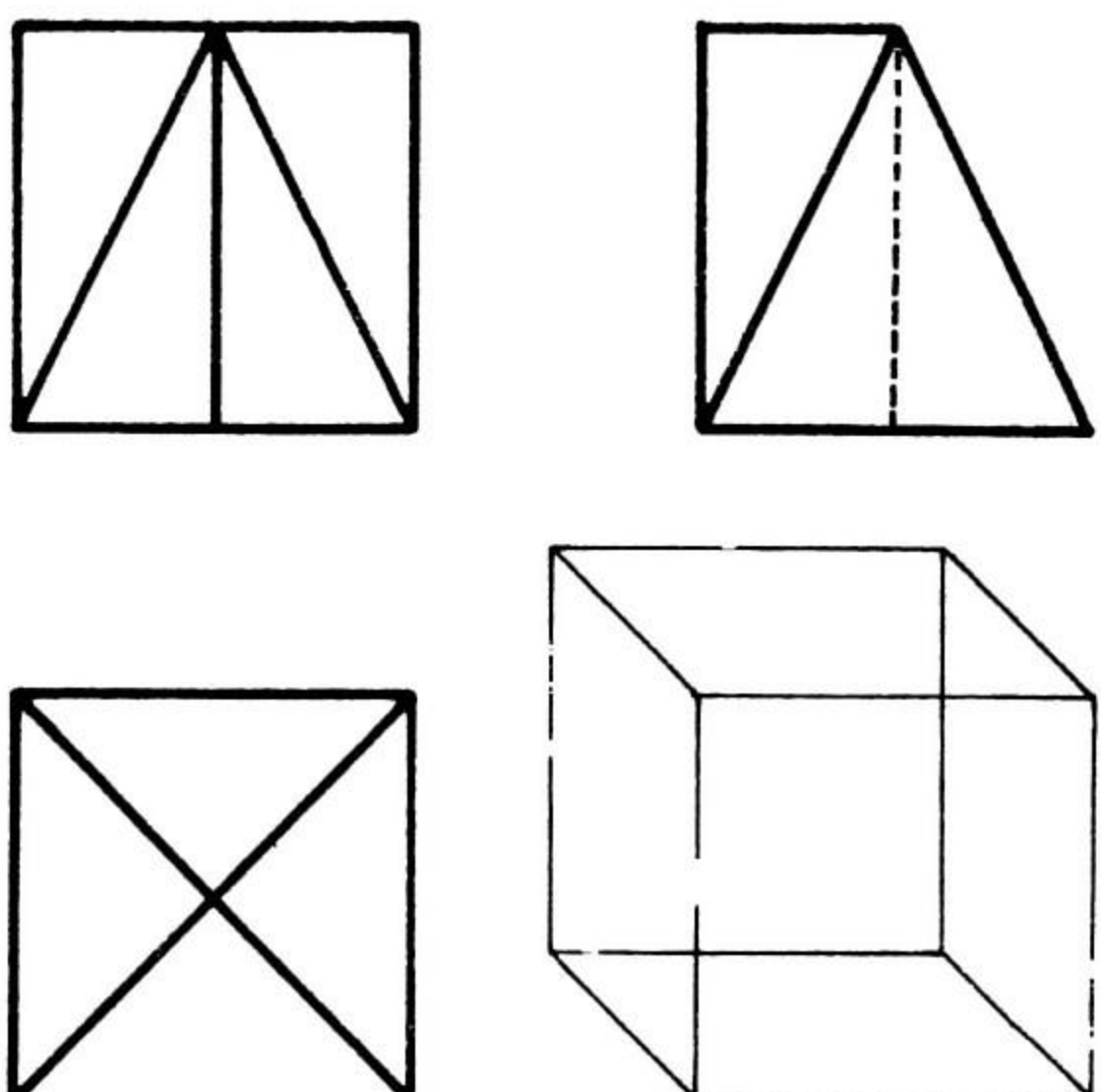
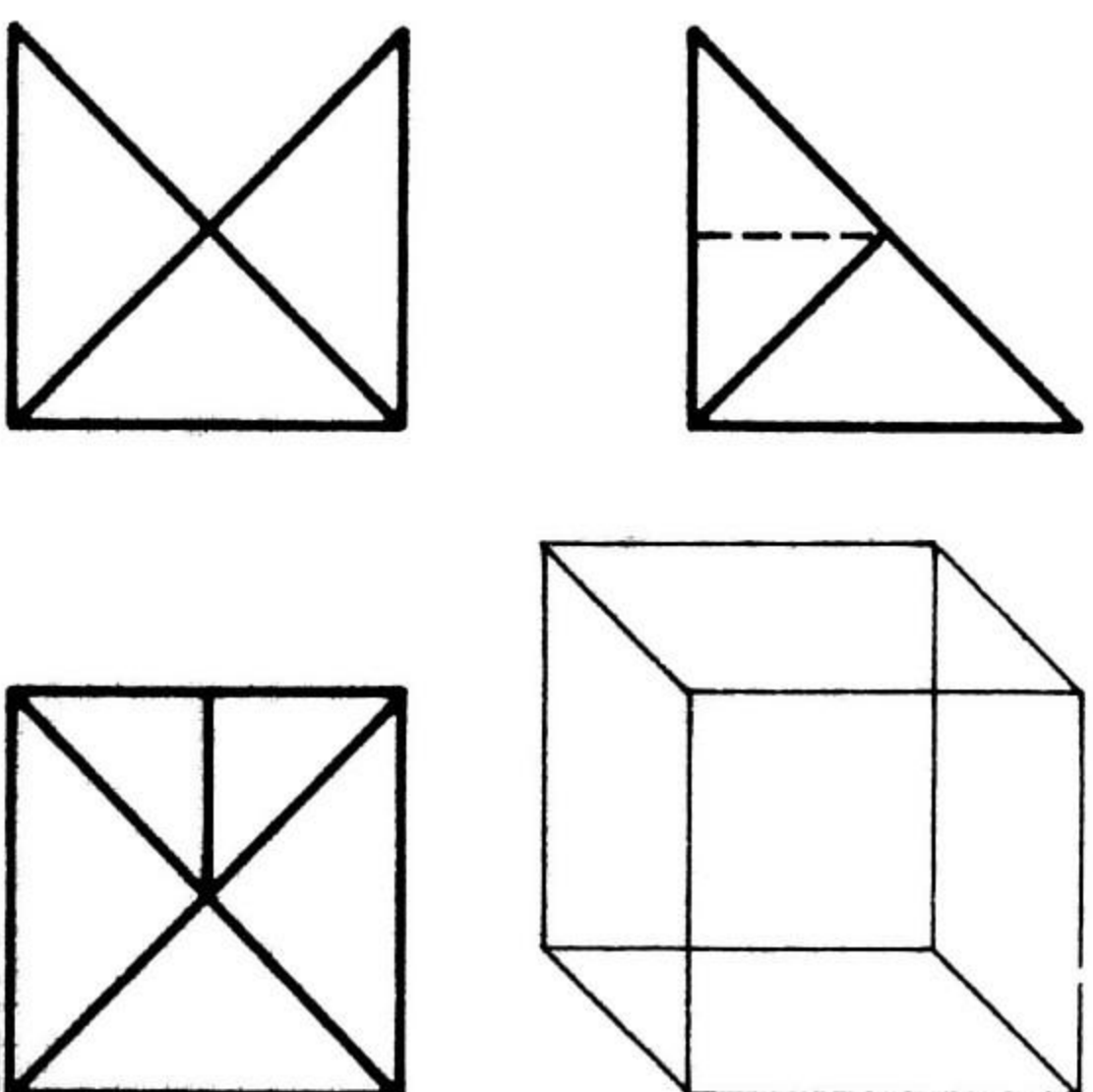
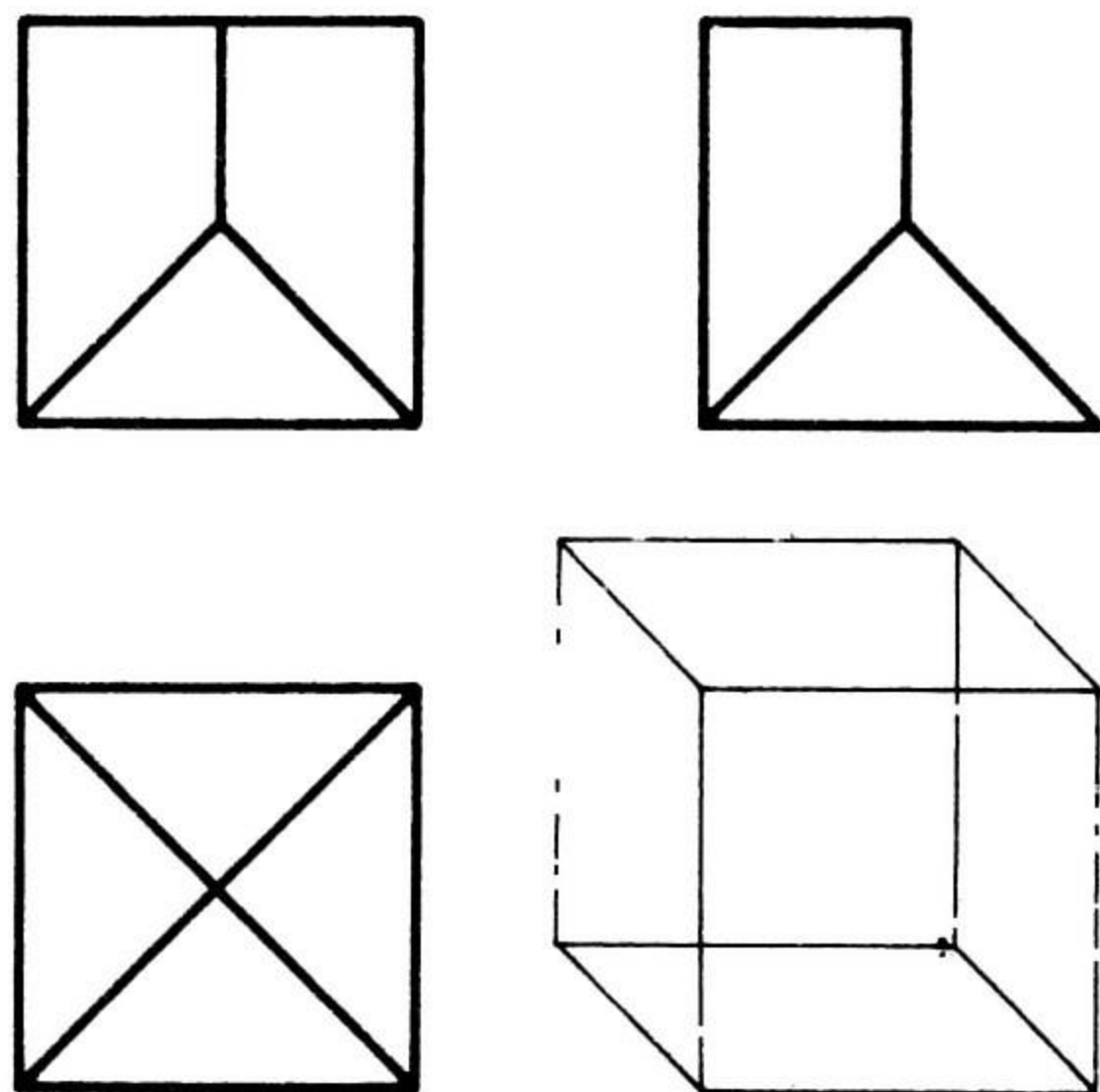
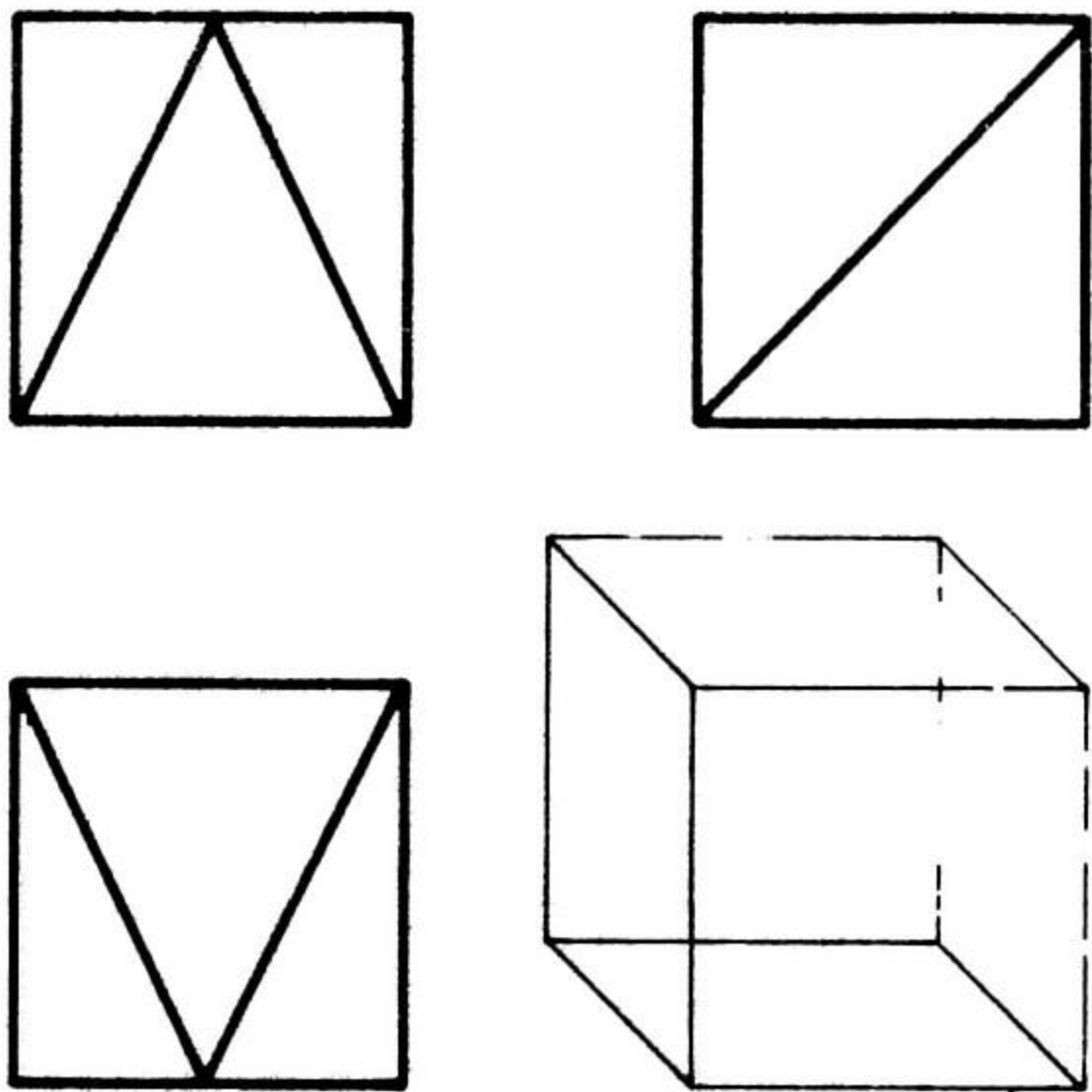
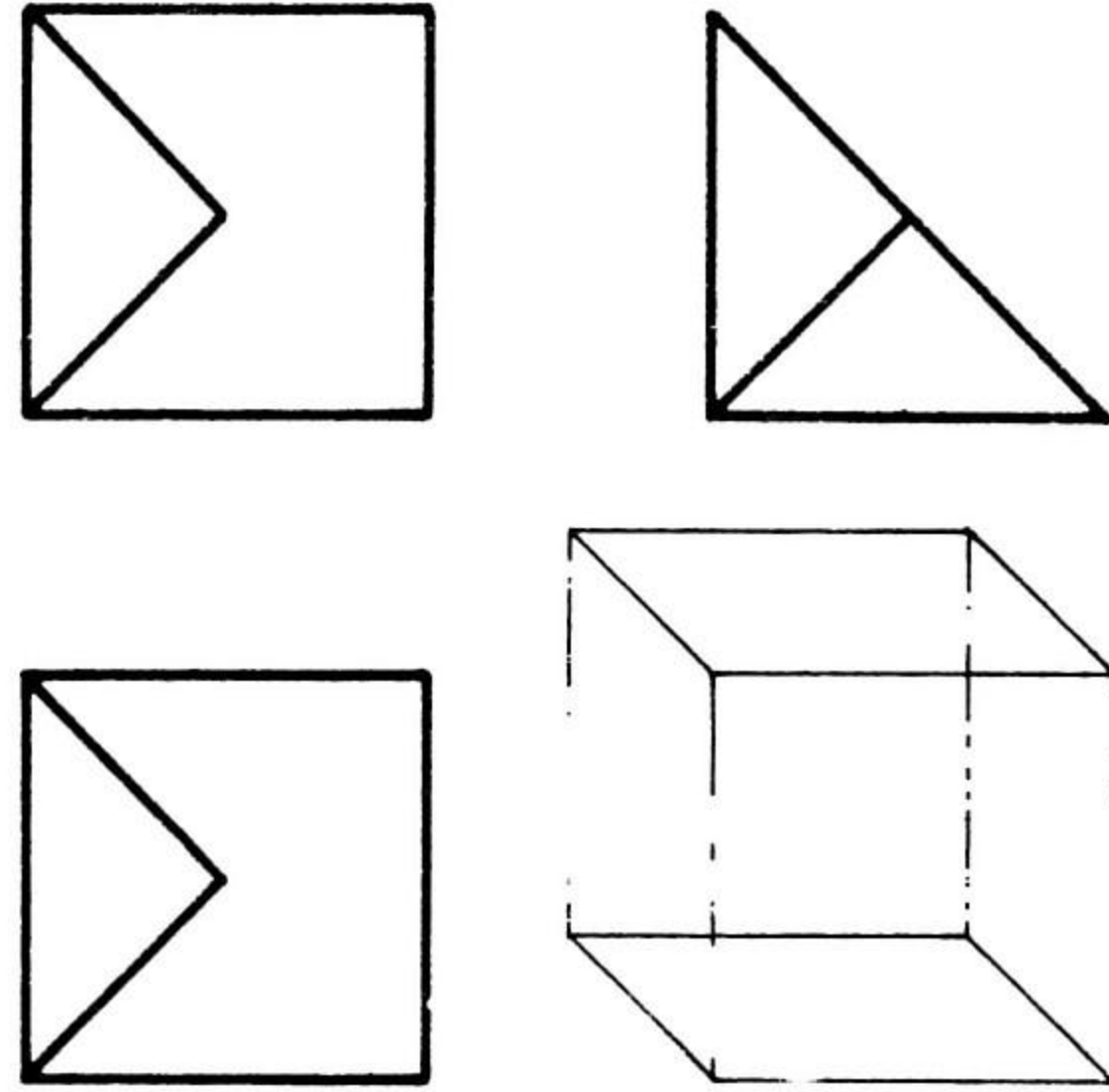
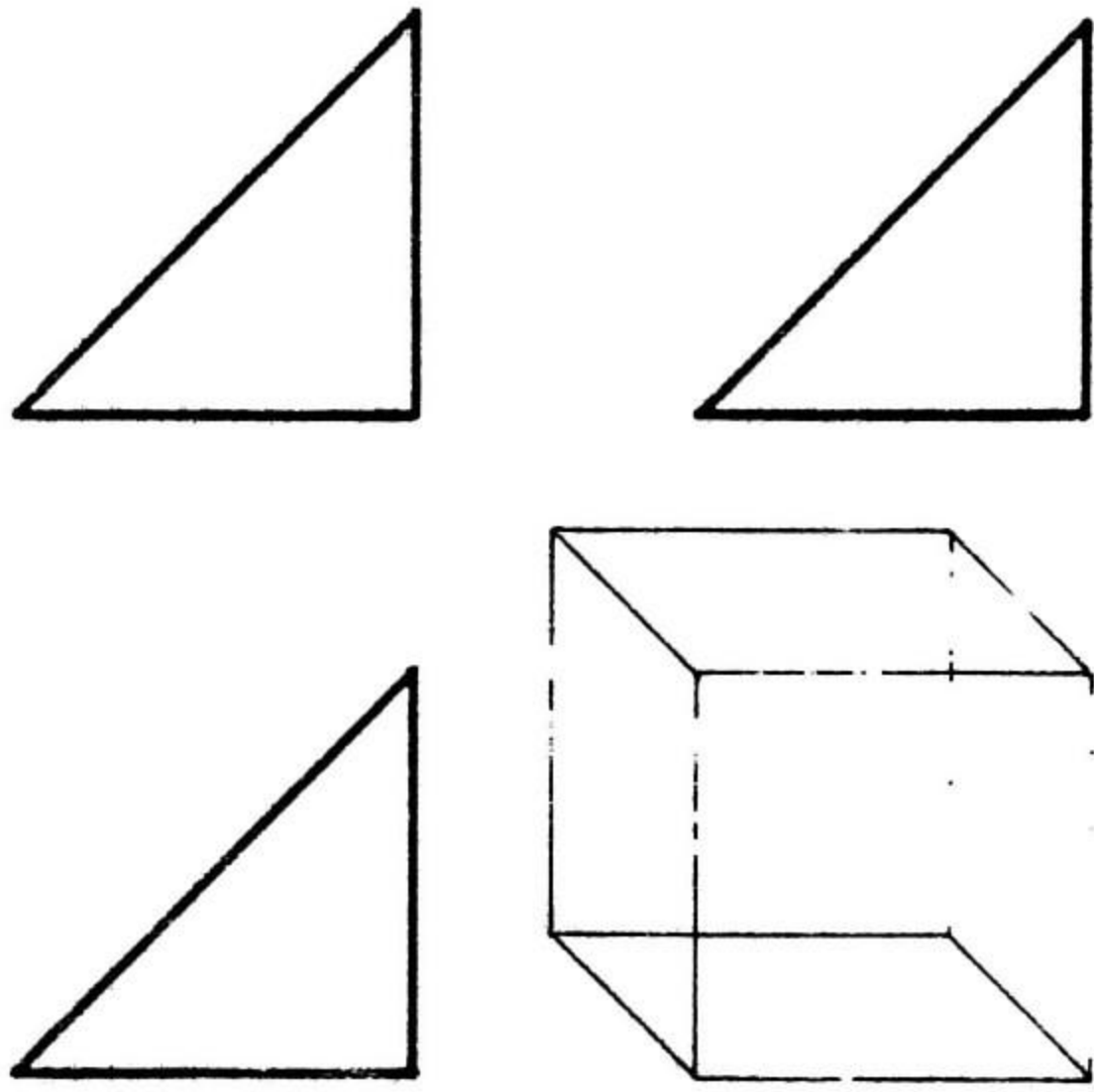

DPTO. DISEÑO BASICO

**ISPJAE
FACULTAD DE ARQUITECTURA**

ASIGNATURA

TEMA

DOC.

ALUM.

No.

GRUPO.

FECHA

EVAL.



5.4.3 INTERPRETACION DE POLIEDROS (VISTAS AUXILIARES O AXONOMETRICOS)

A

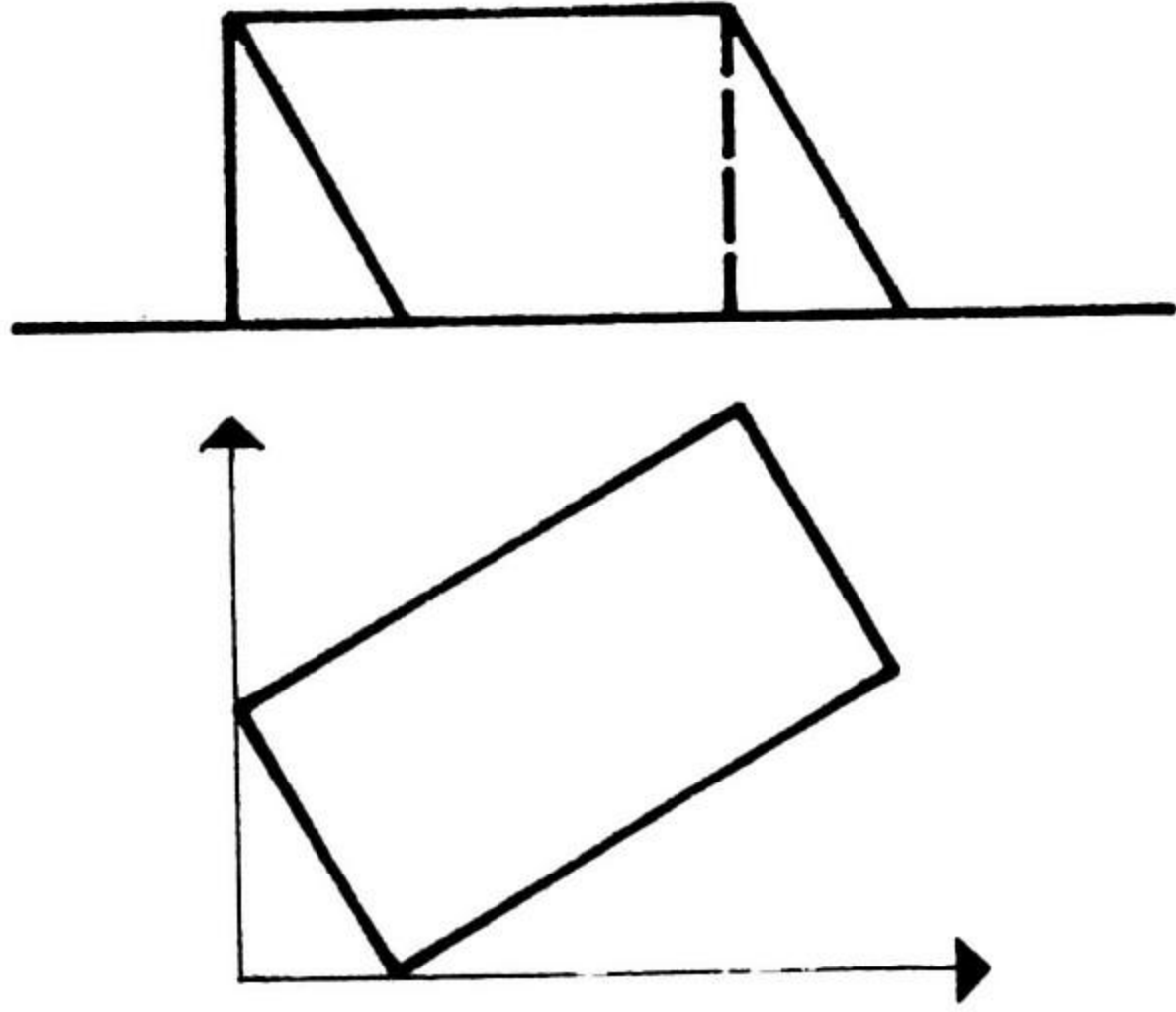

B

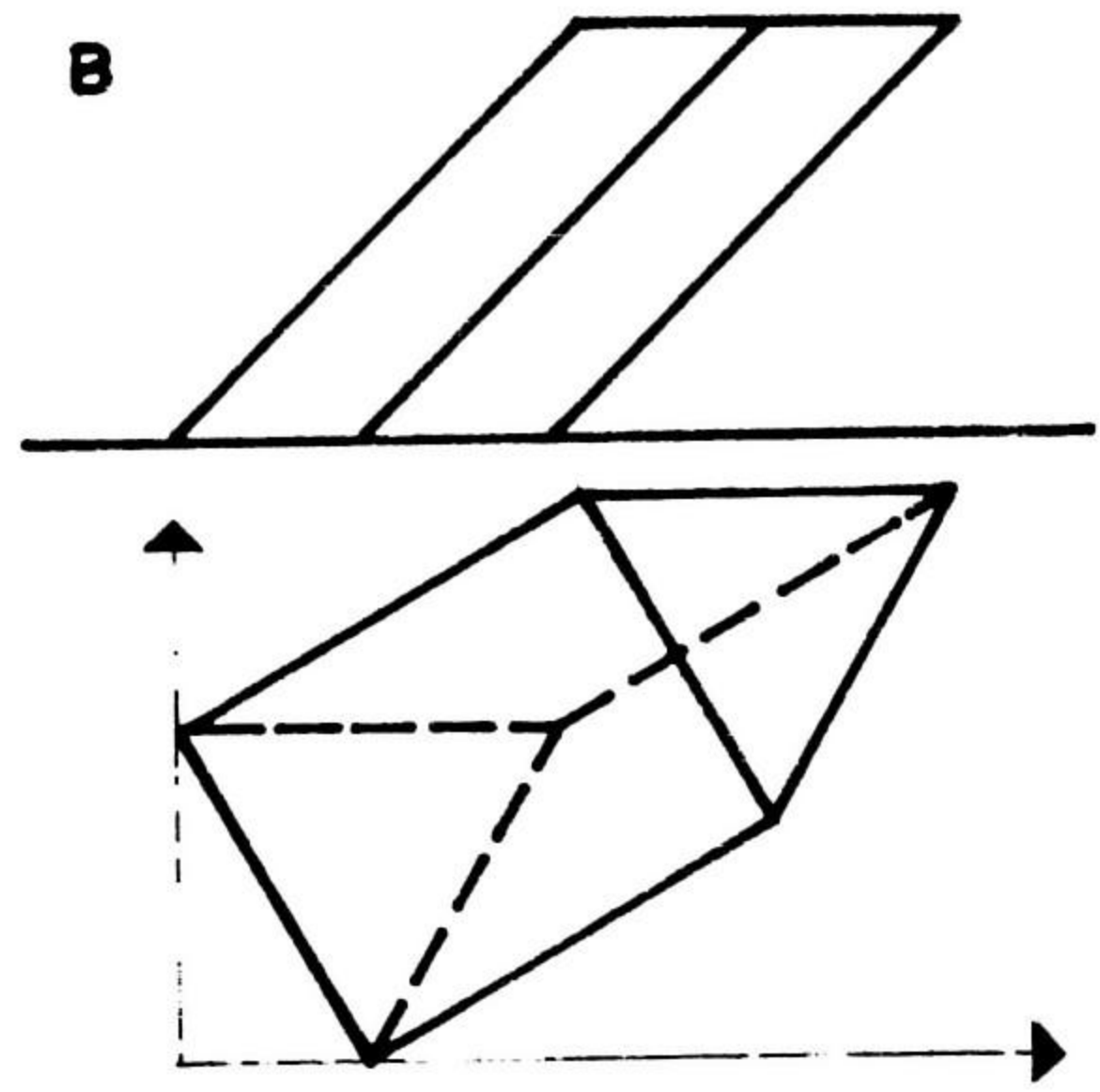

C

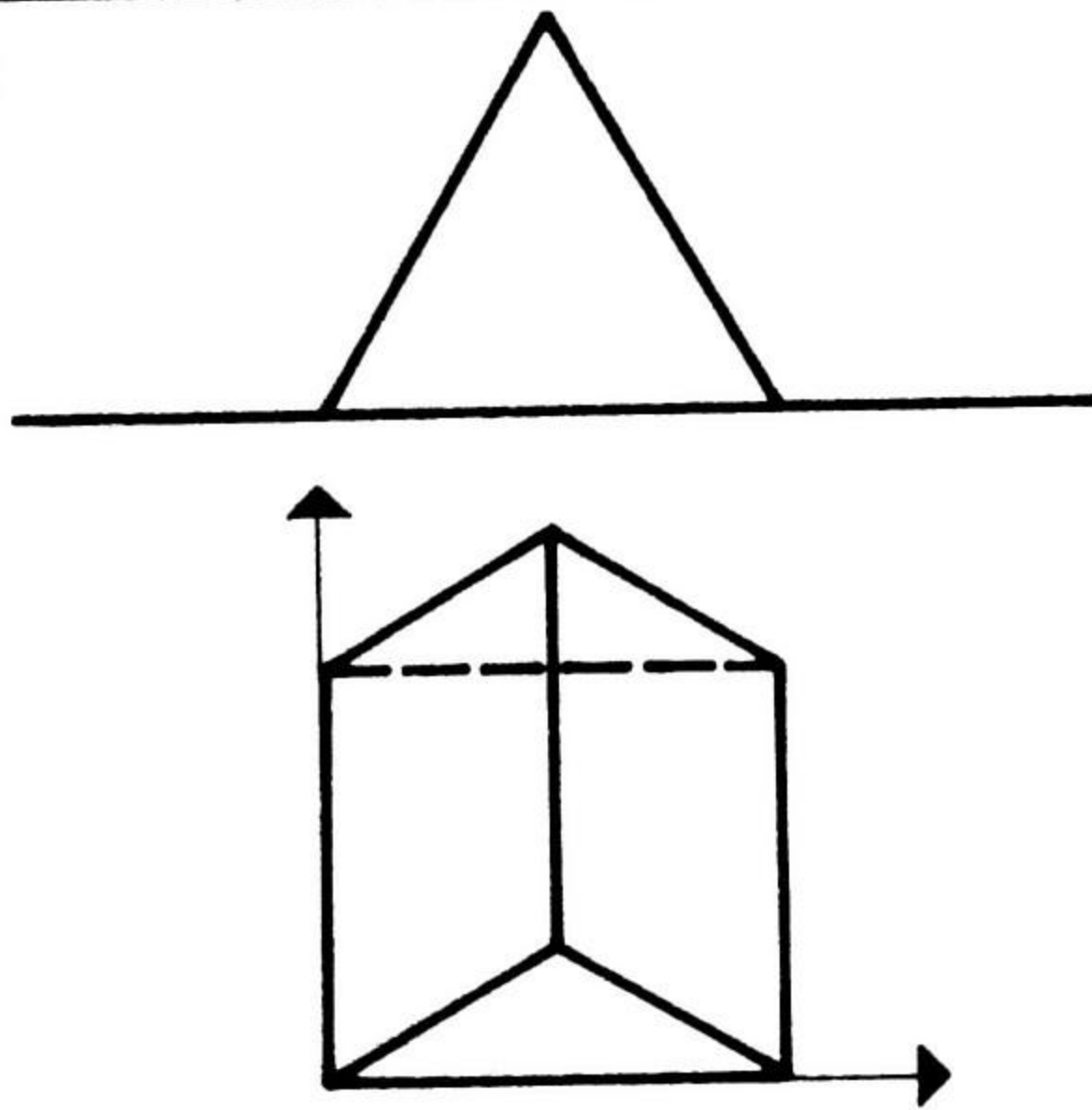

D

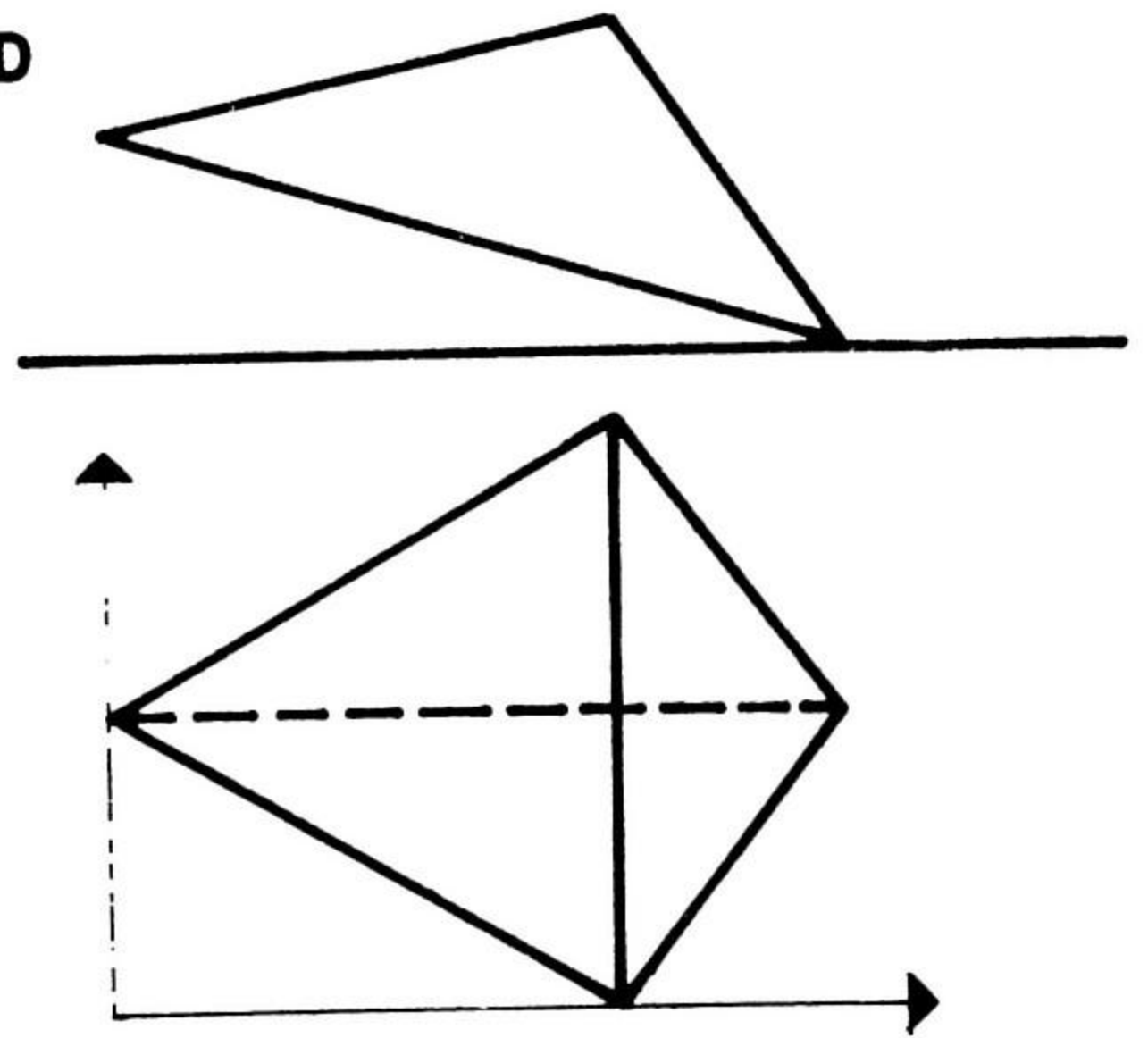

E

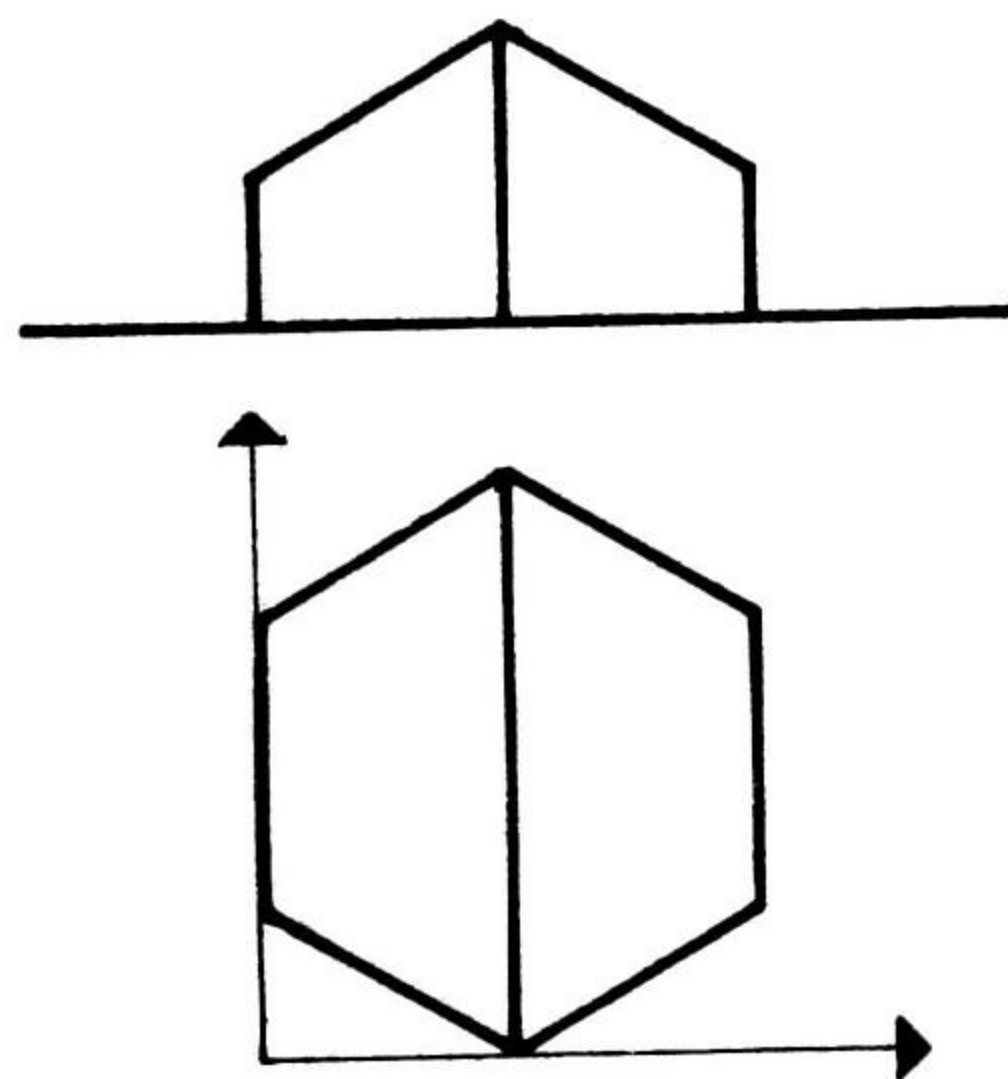

F

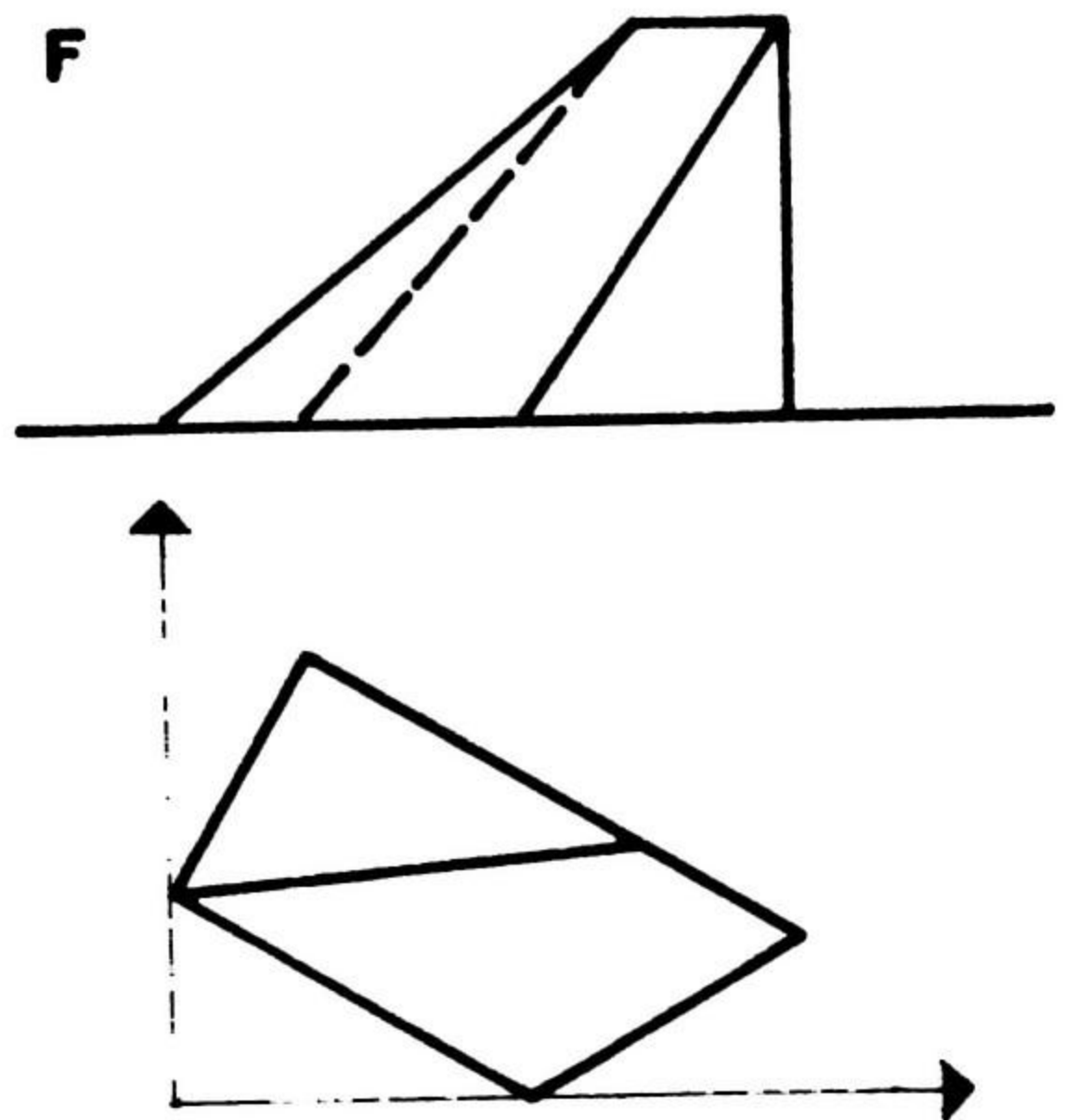

DPTO. DISEÑO BASICO

ISPJAE FACULTAD DE ARQUITECTURA

ASIGNATURA	TEMA	No.	GRPO.
DOC.	ALUM.	EVAL.	
FECHA			

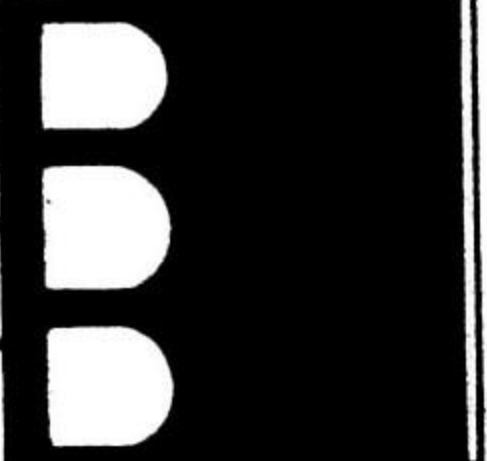

5.4.3 INTERPRETACION DE POLIEDROS (DESARROLLO)

G

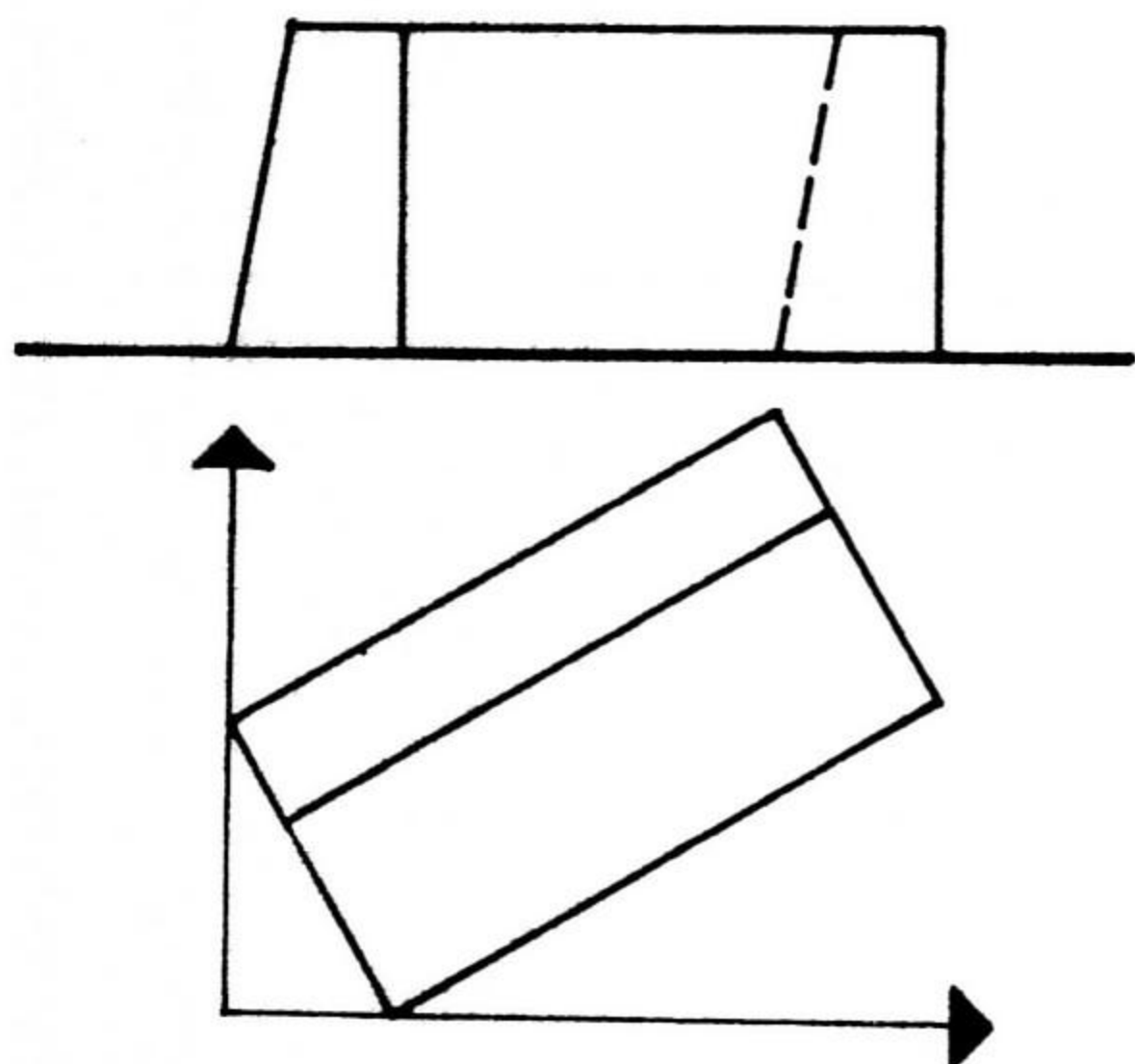

H

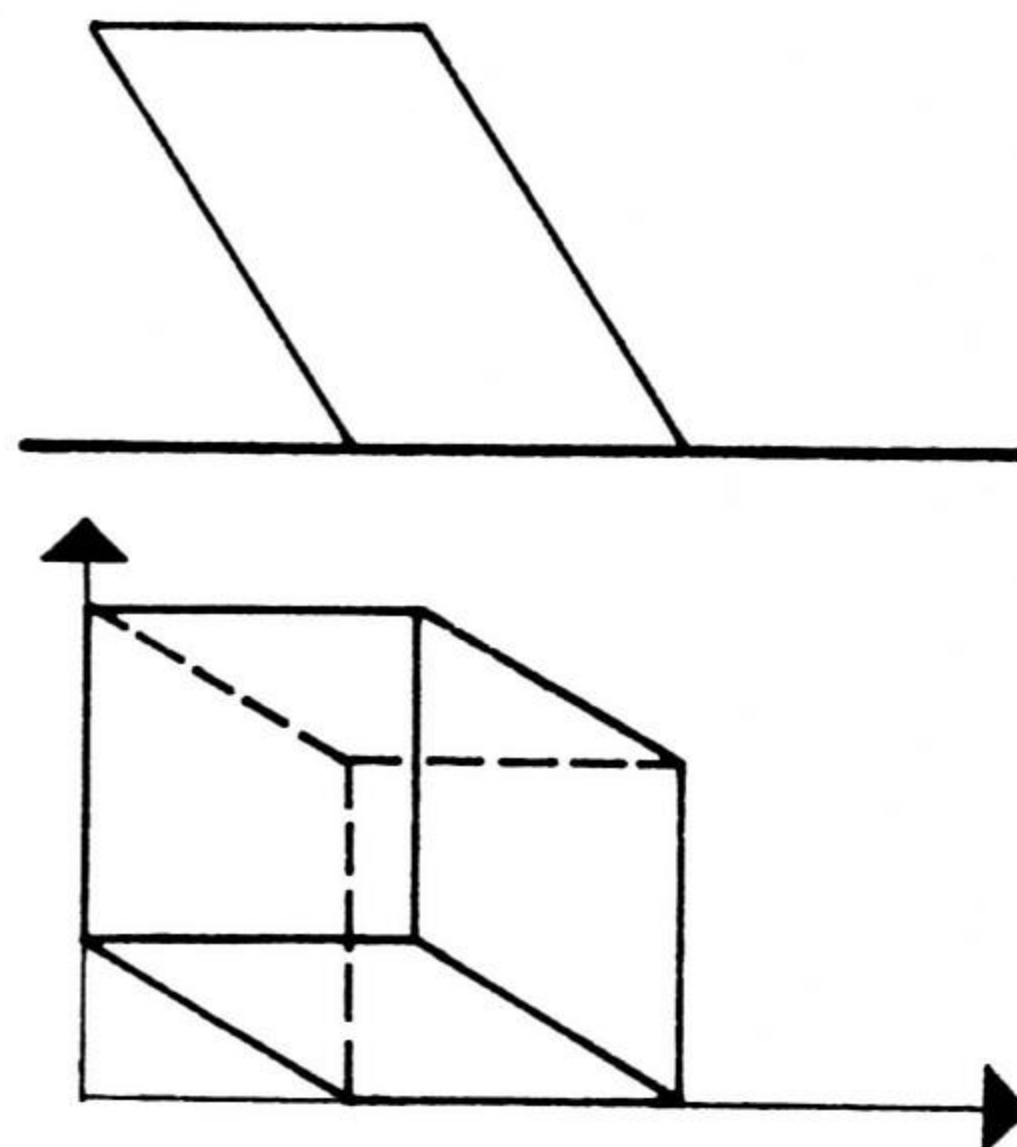

I

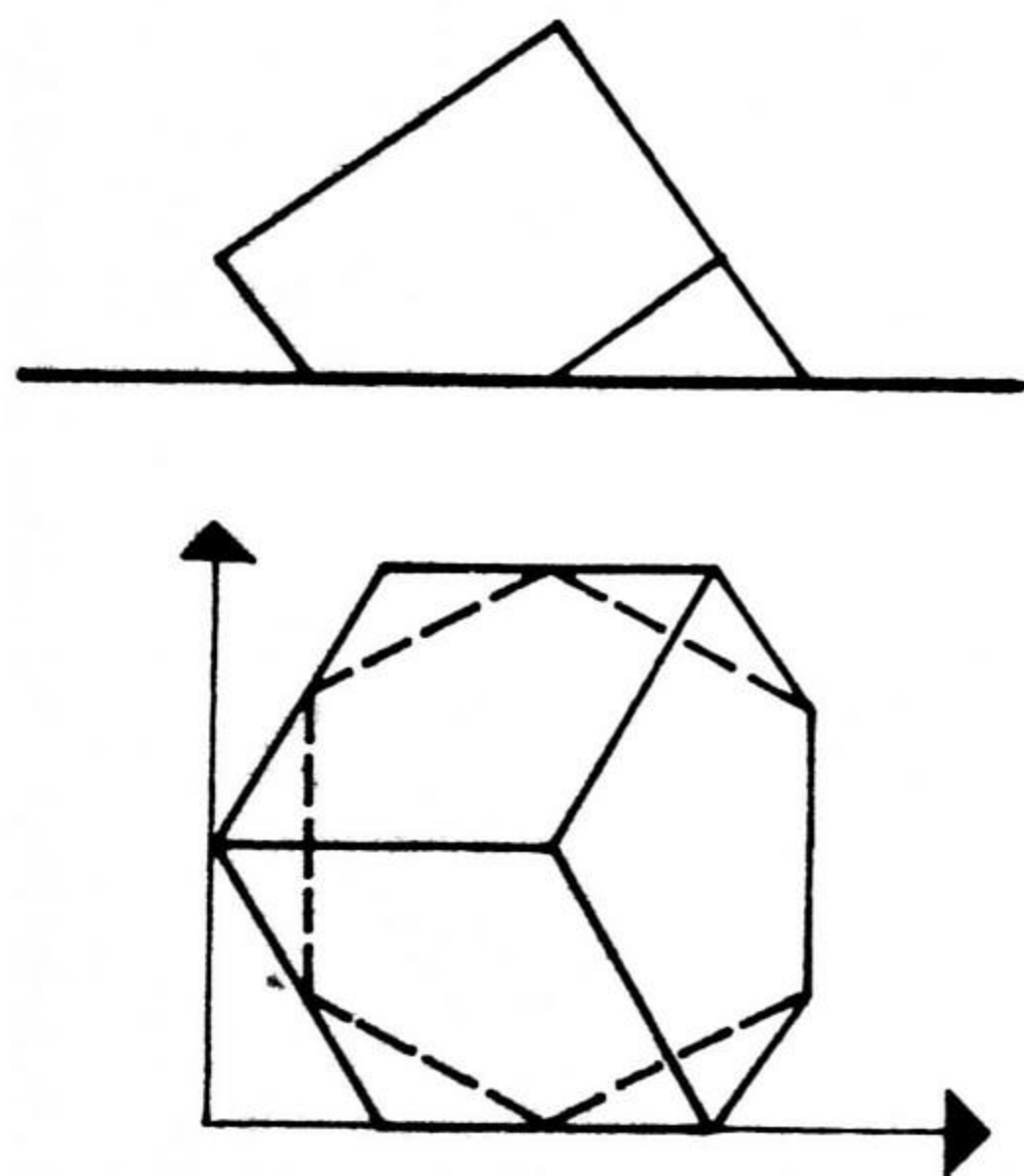

J

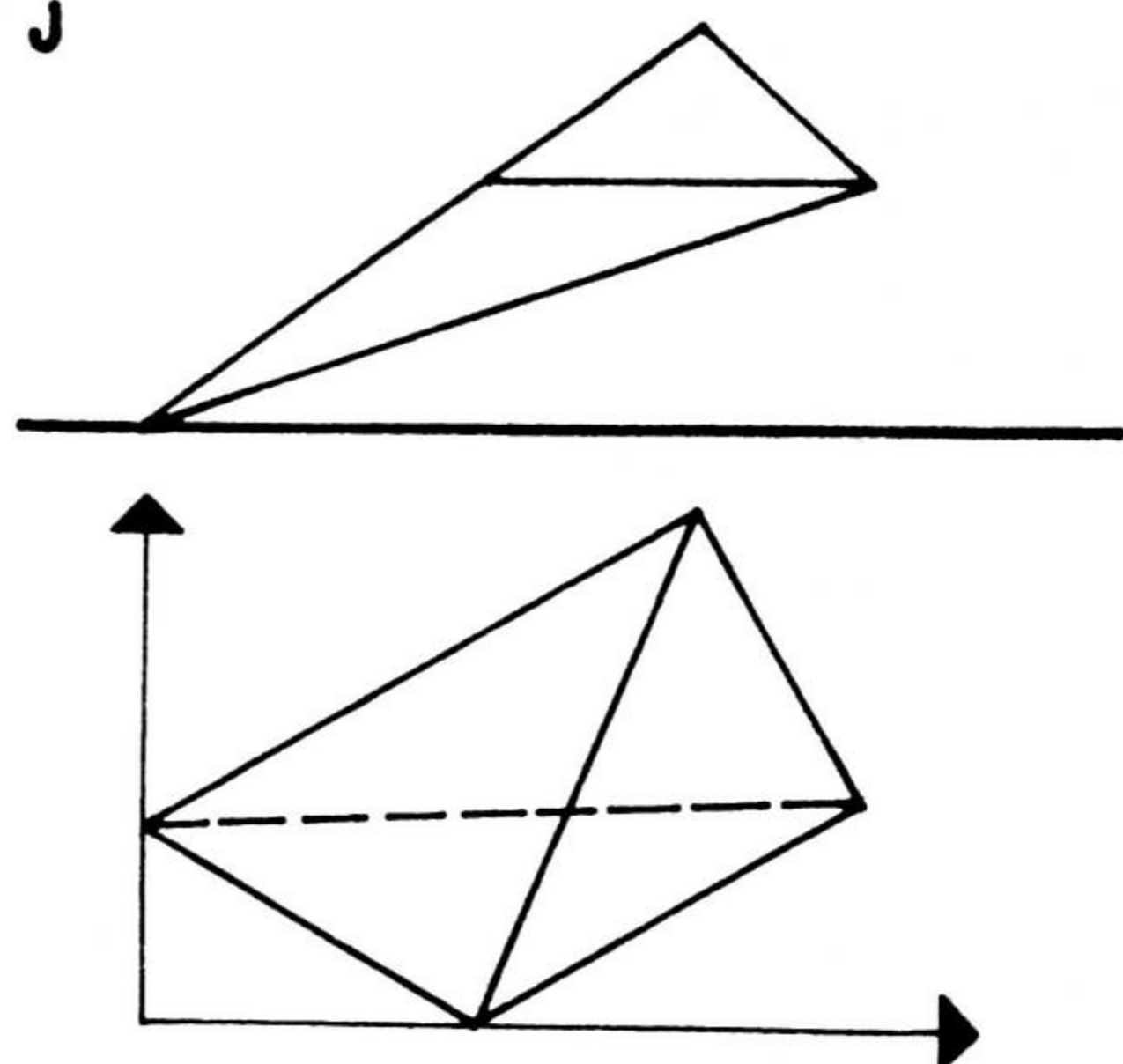

K

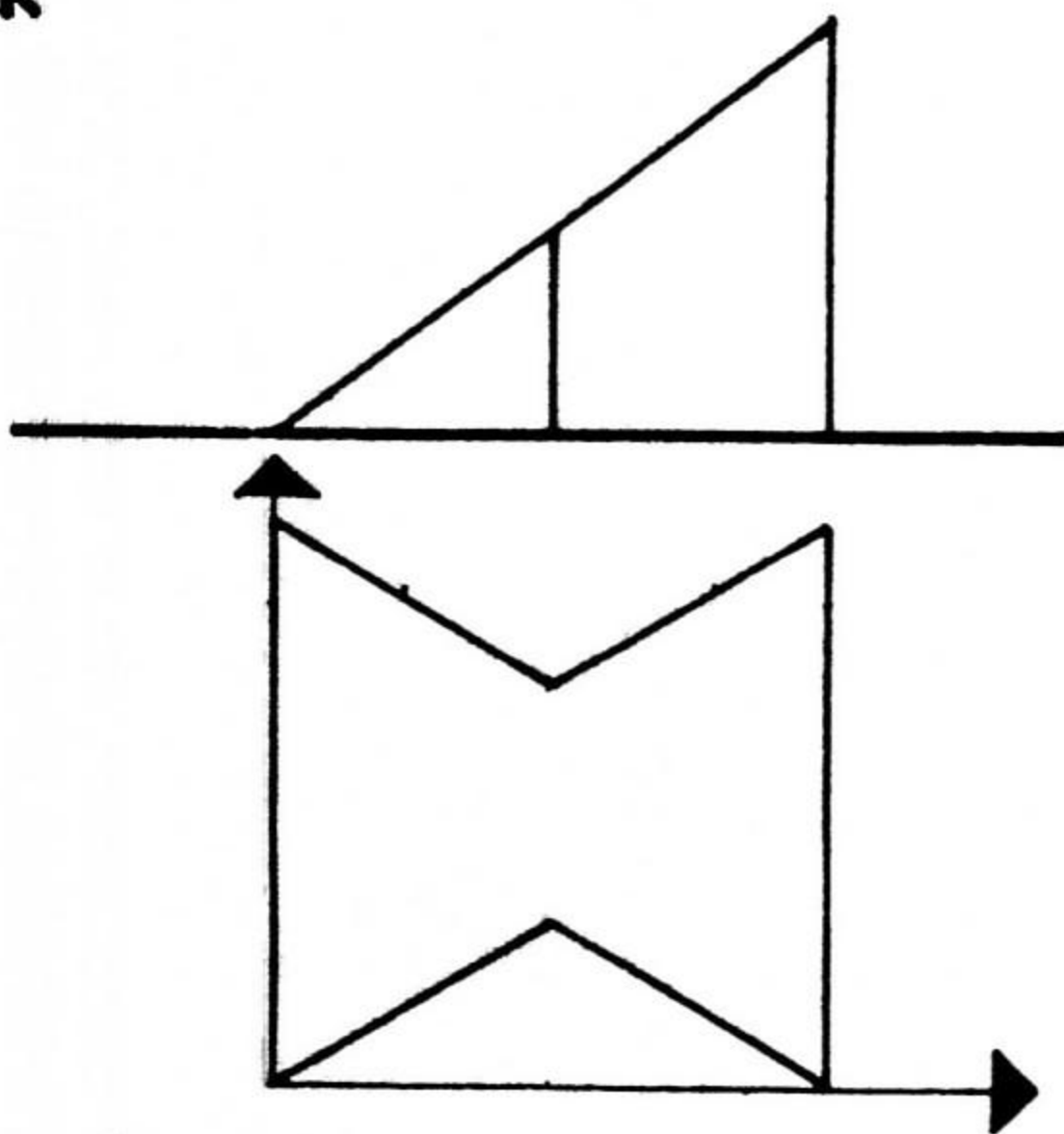

L

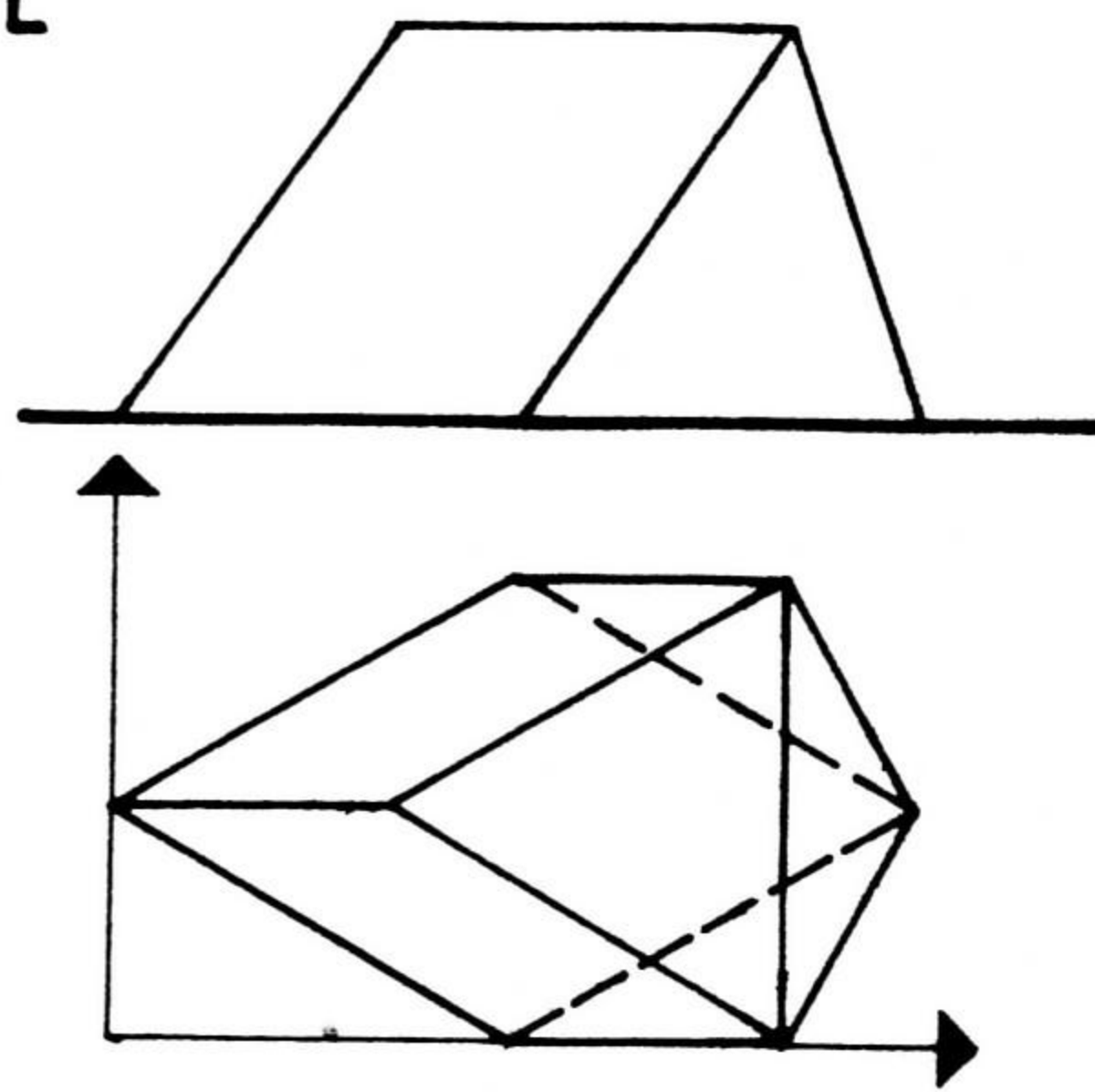

DPTO. DISEÑO BASICO

ISPJAE FACULTAD DE ARQUITECTURA

ASIGNATURA

TEMA

DOC.

ALUM.

No.

GRUPO.

FECHA

EVAL.

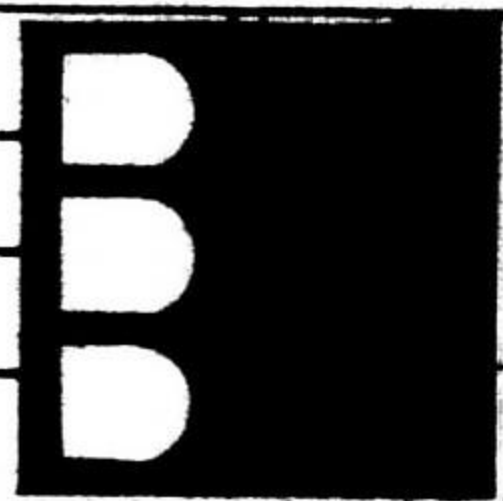

5.5.2 INTERSECCIONES — RECTA CON POLIEDRO — VISIBILIDAD.

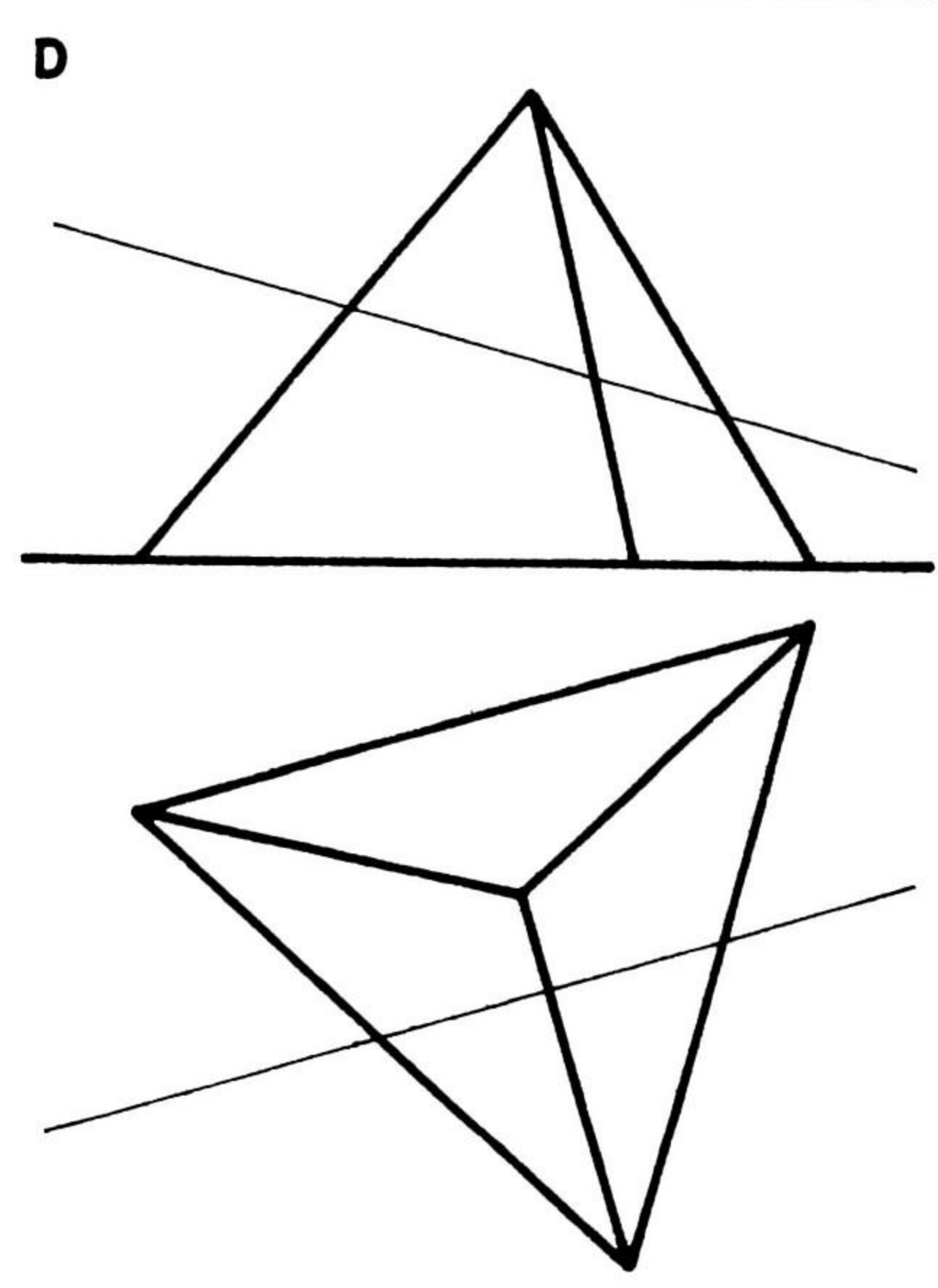
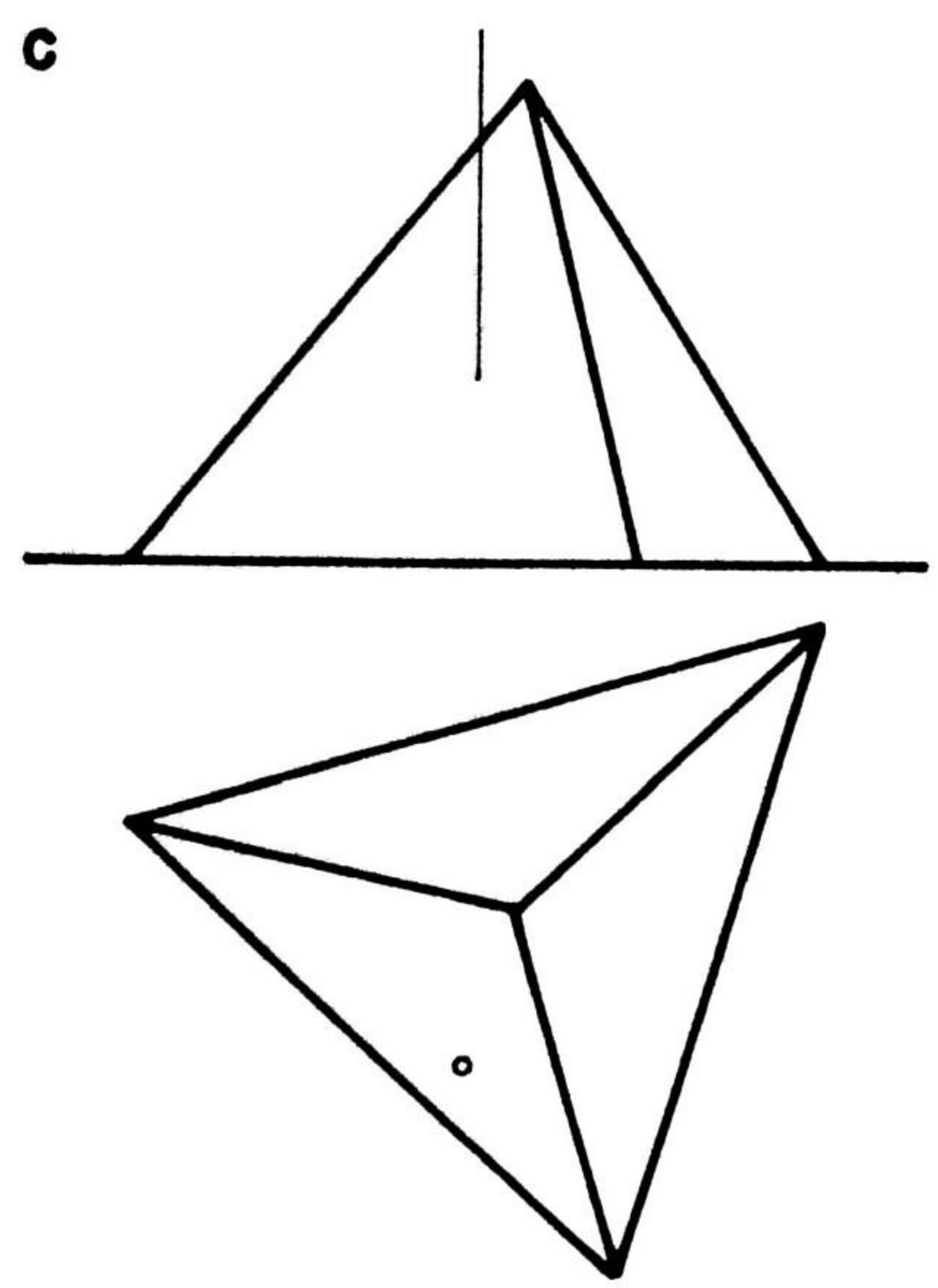
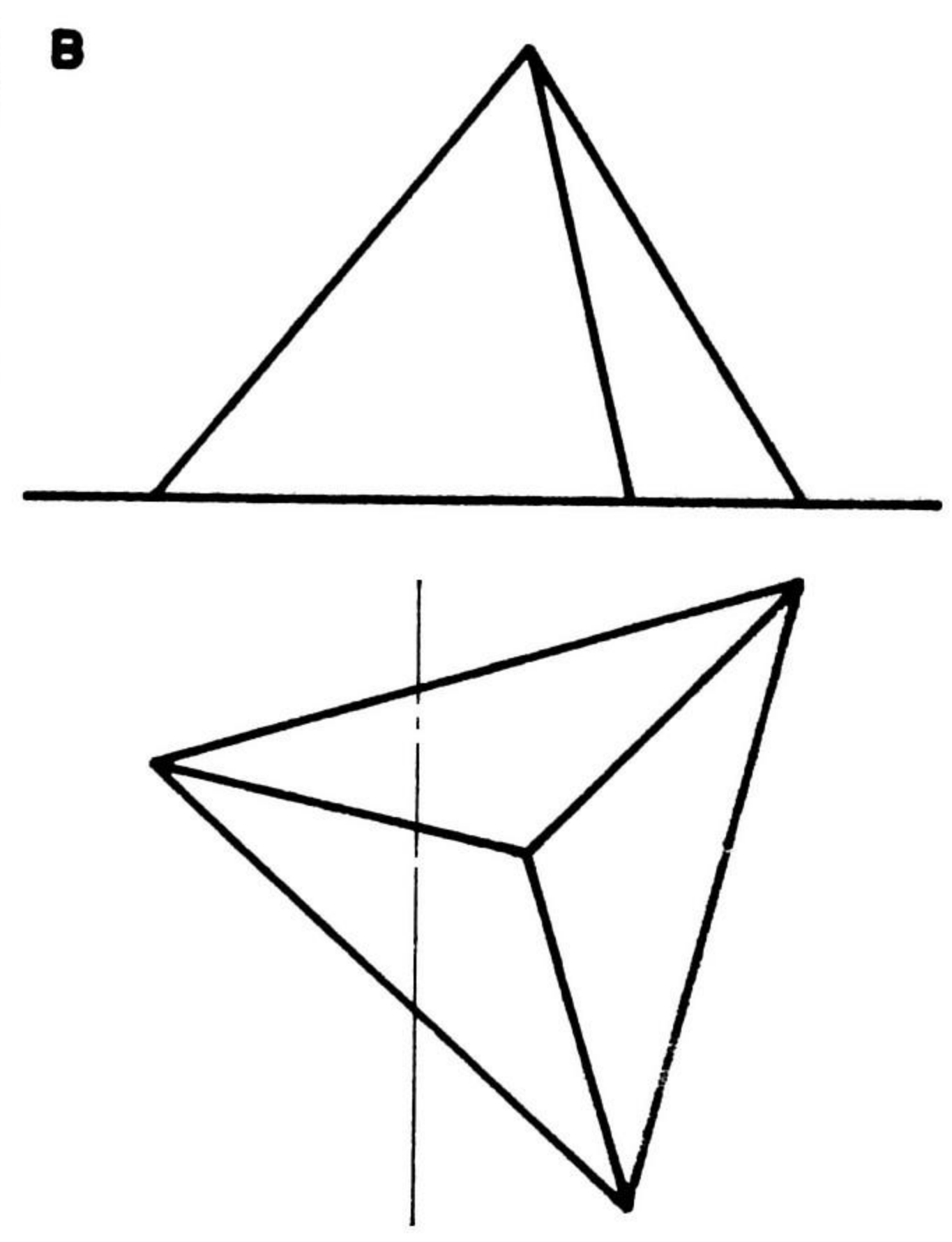
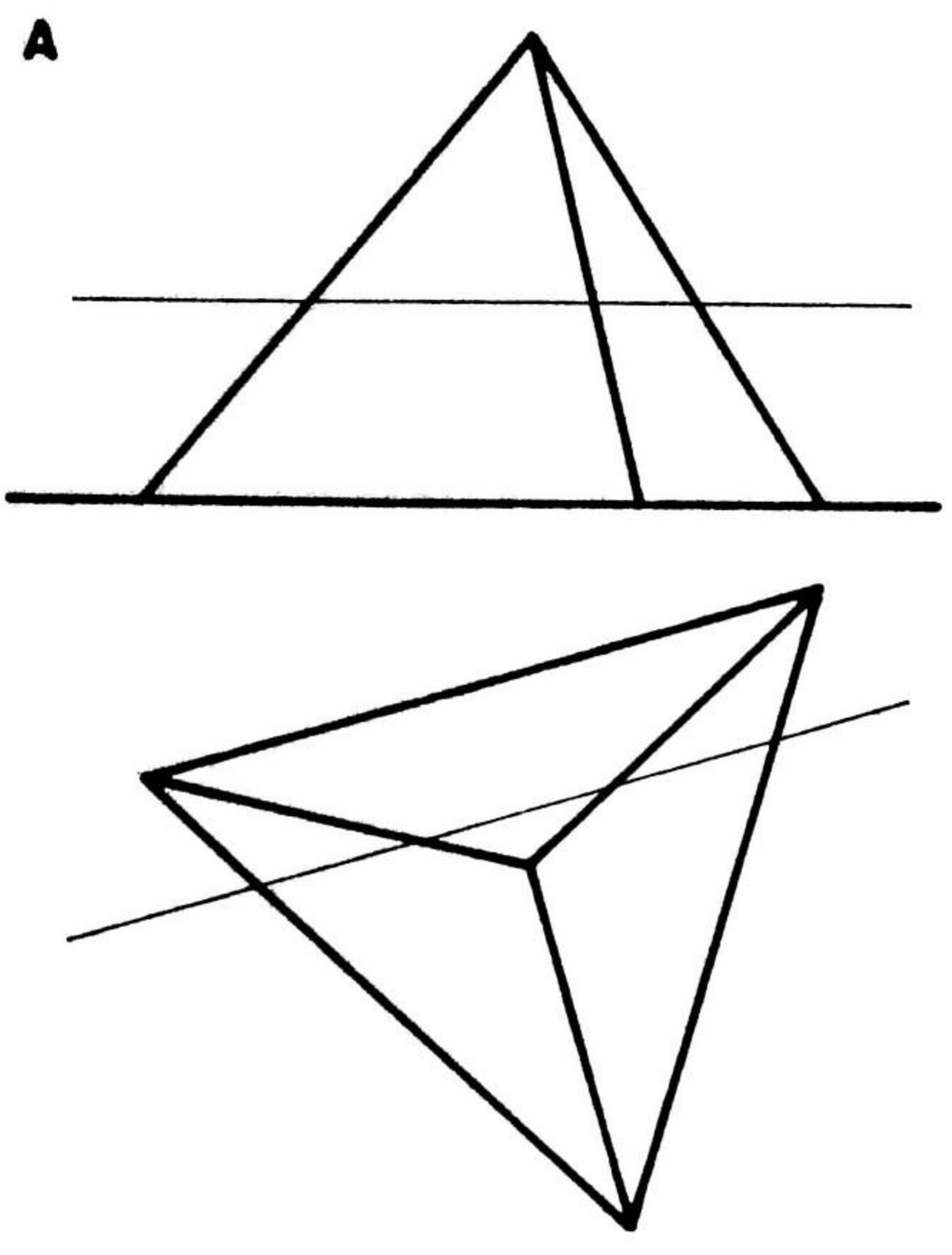

DPTO. DISEÑO BASICO		ISPJAE		FACULTAD DE ARQUITECTURA	
ASIGNATURA	TEMA				
DOC.	ALUM.		No.	GRUPO.	
FECHA				EVAL.	

5.5.2 INTERSECCIONES – FIGURA PLANA CON POLIEDRO – VISIBILIDAD

A

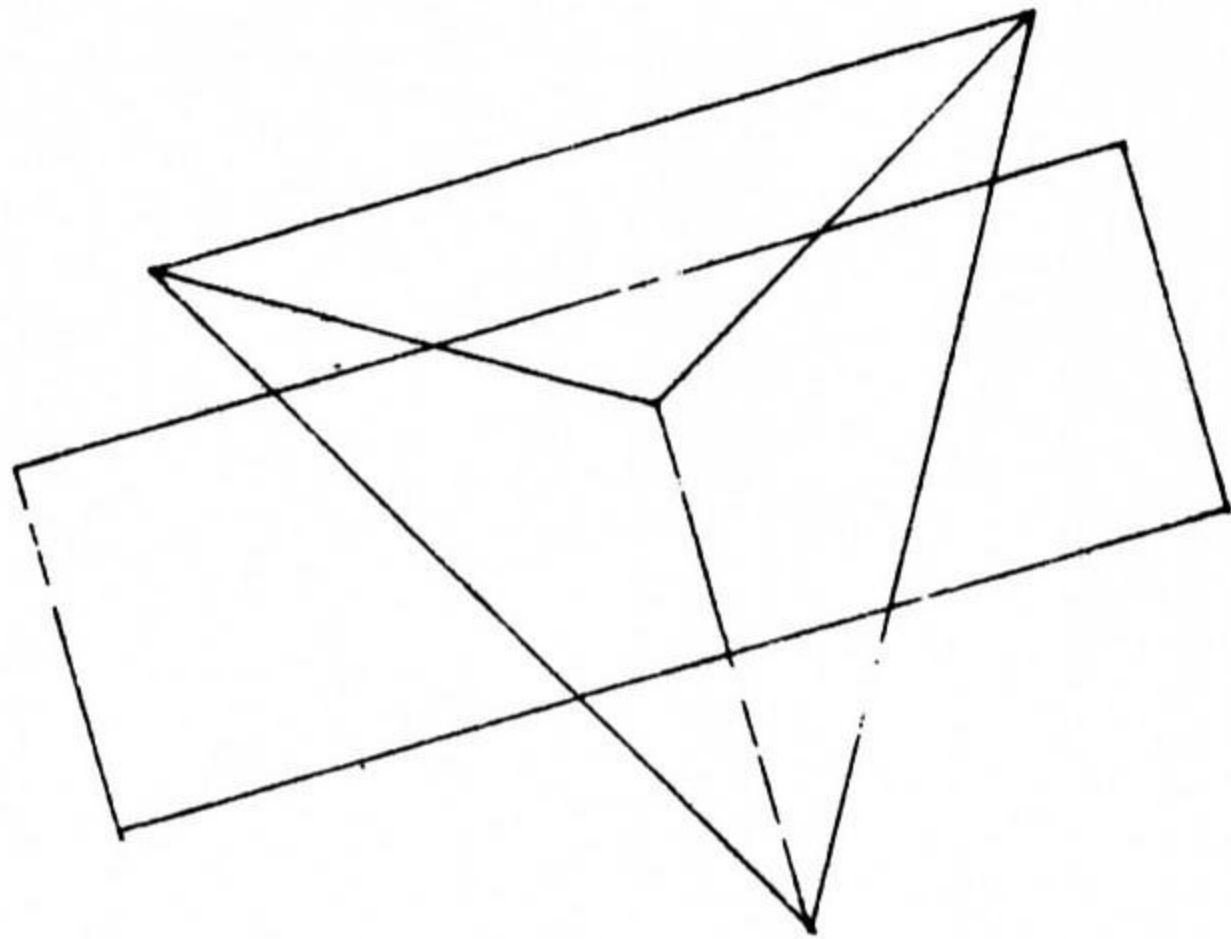
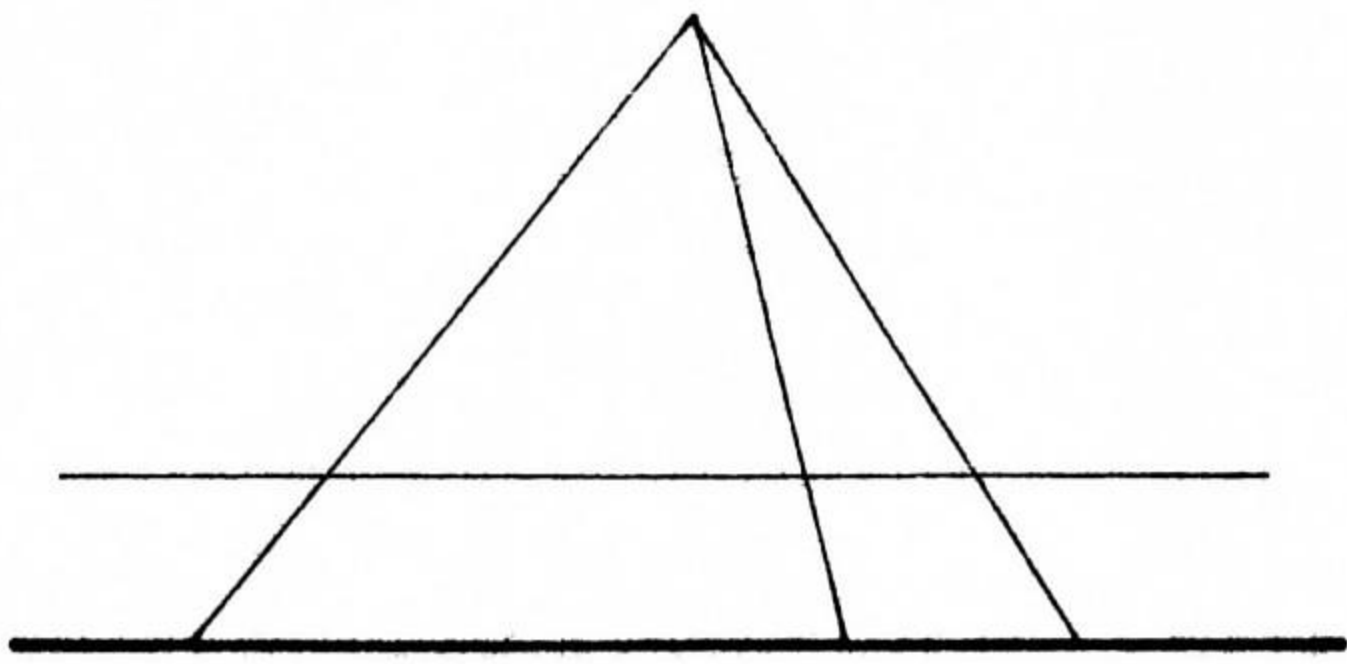

B

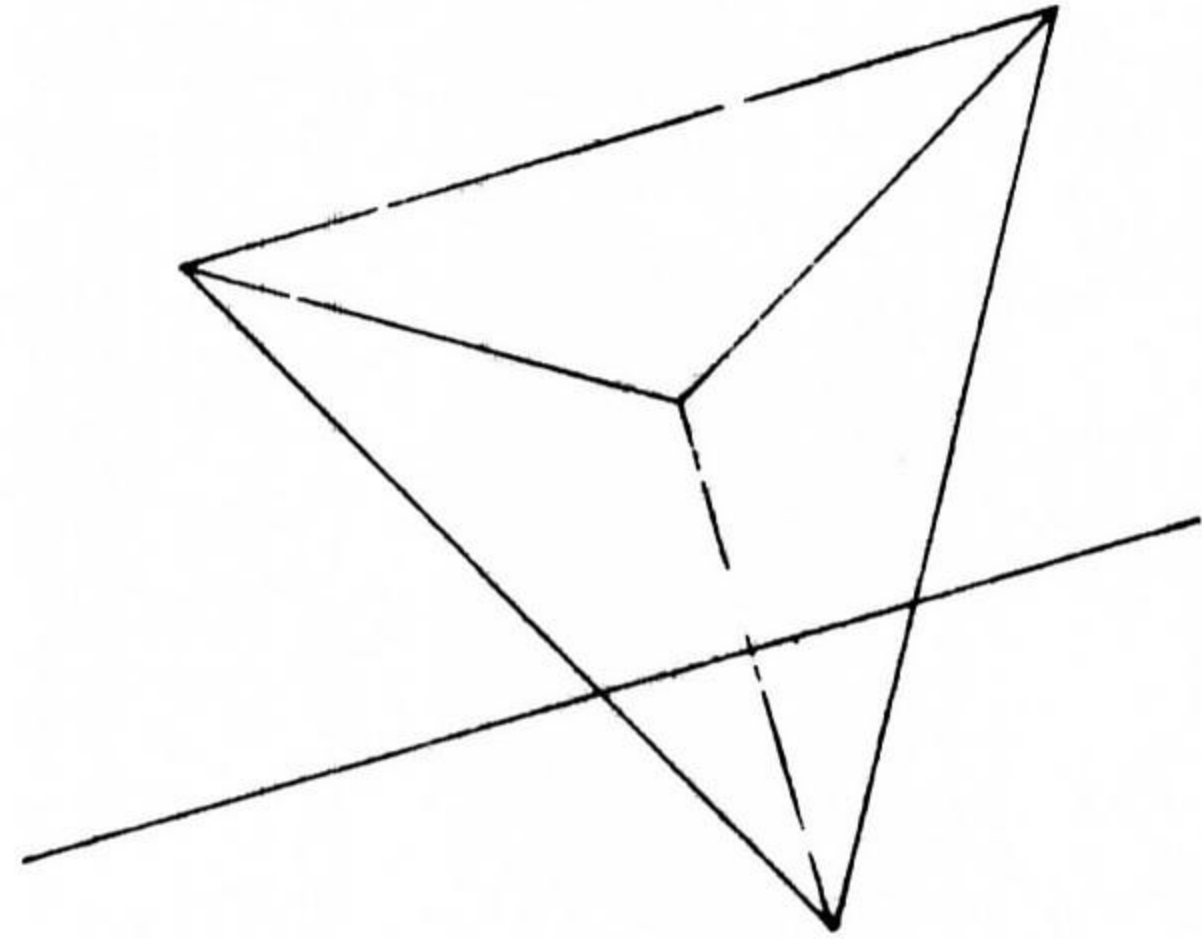
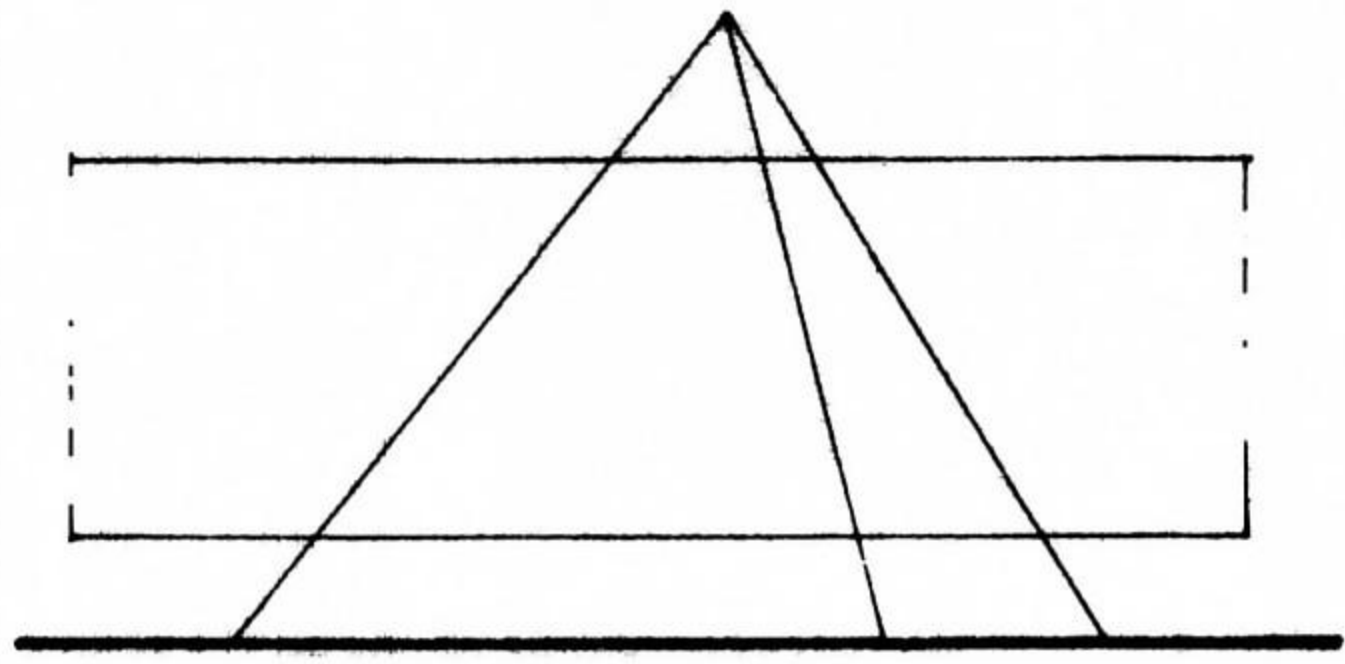

C

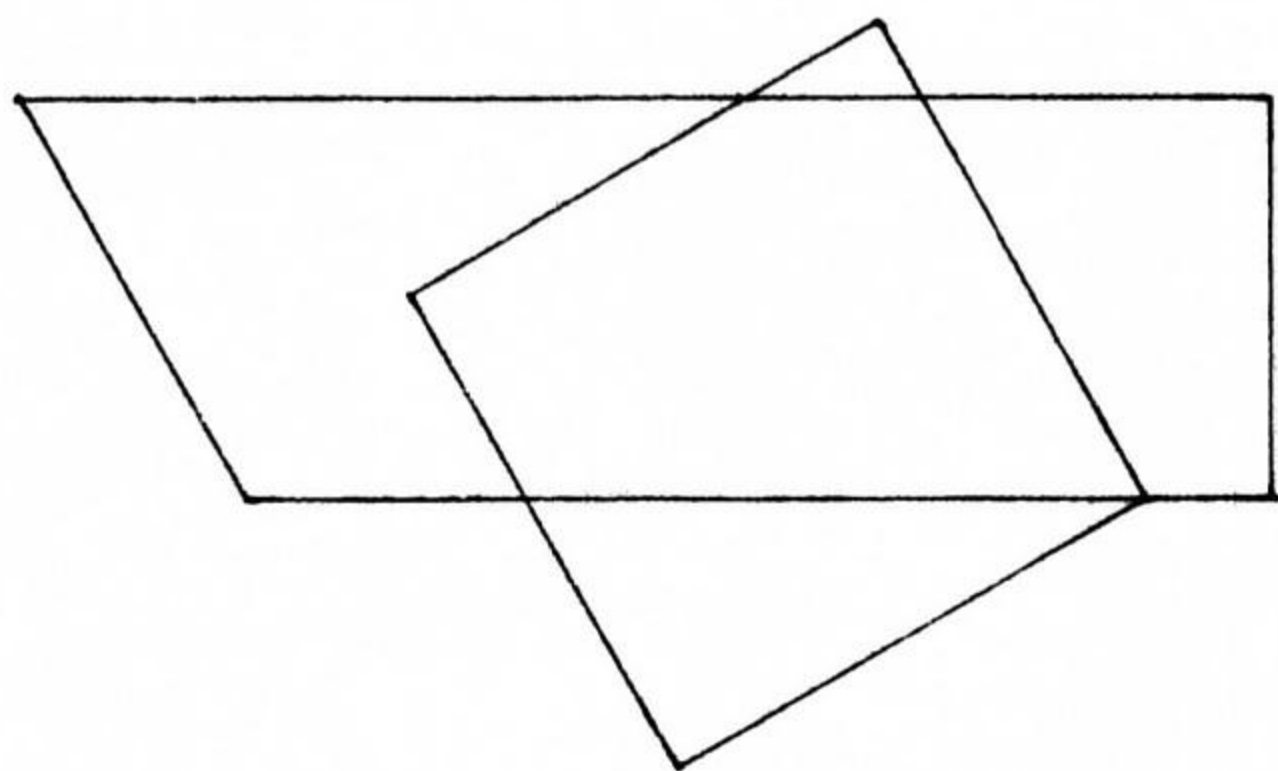
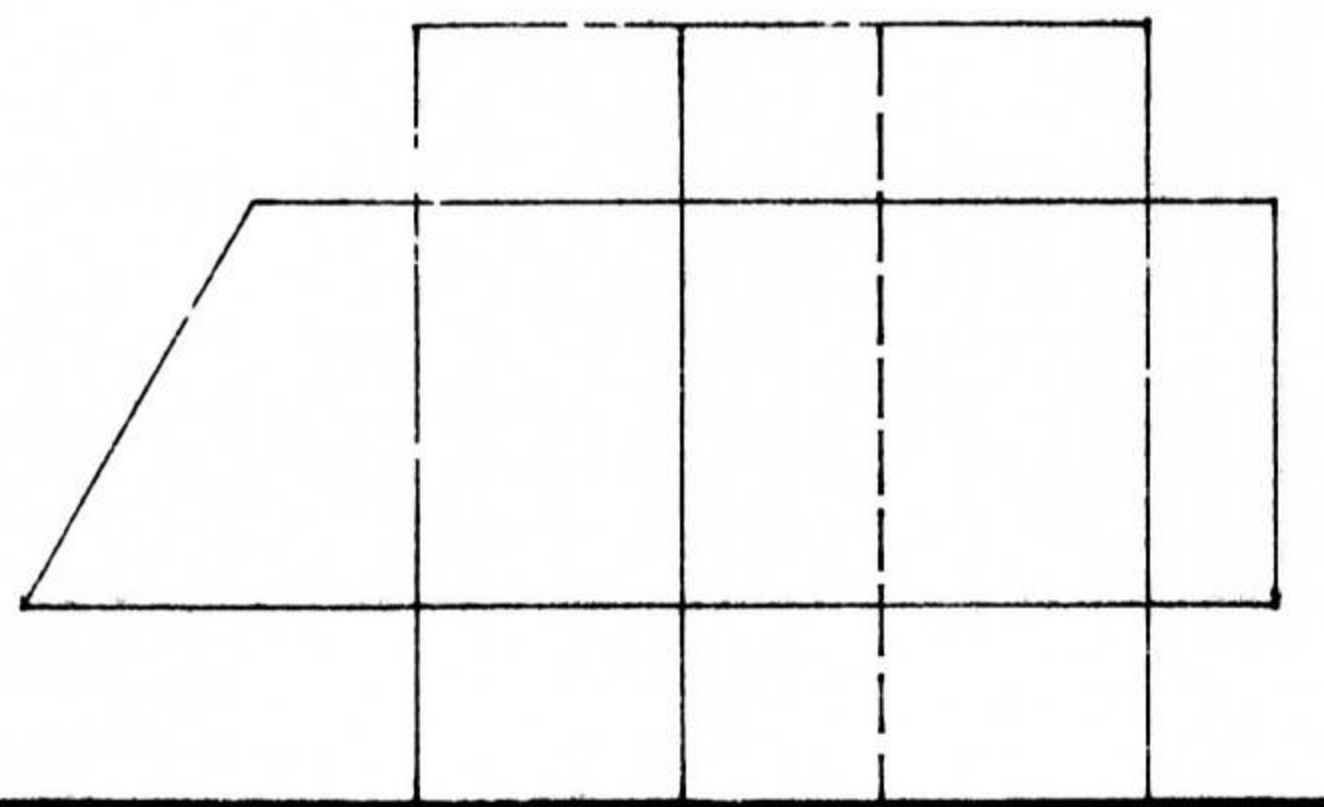

D

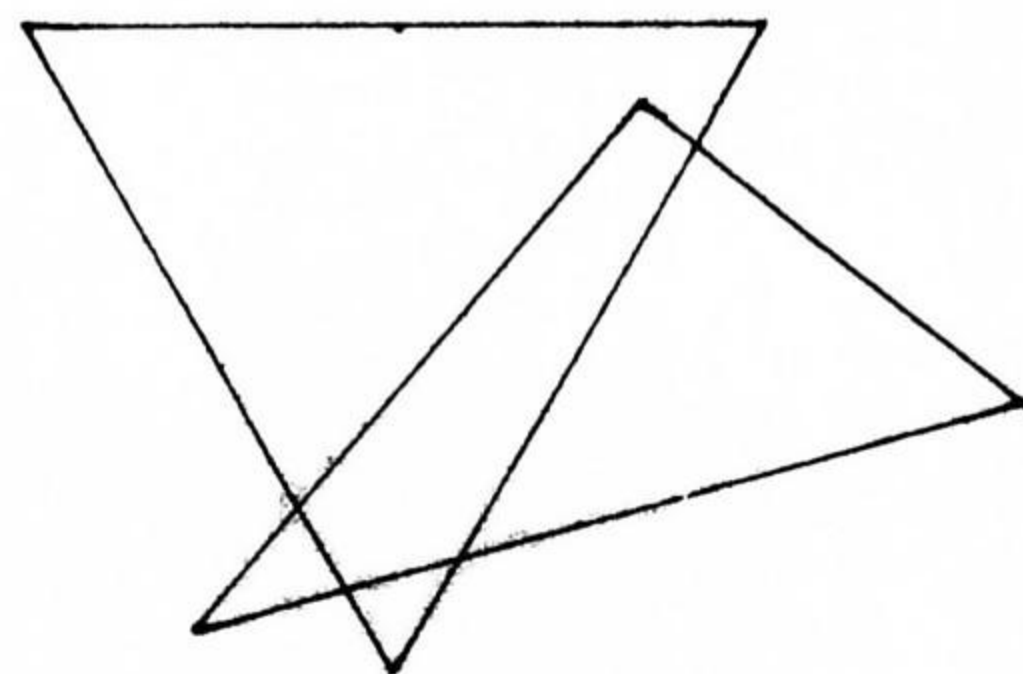
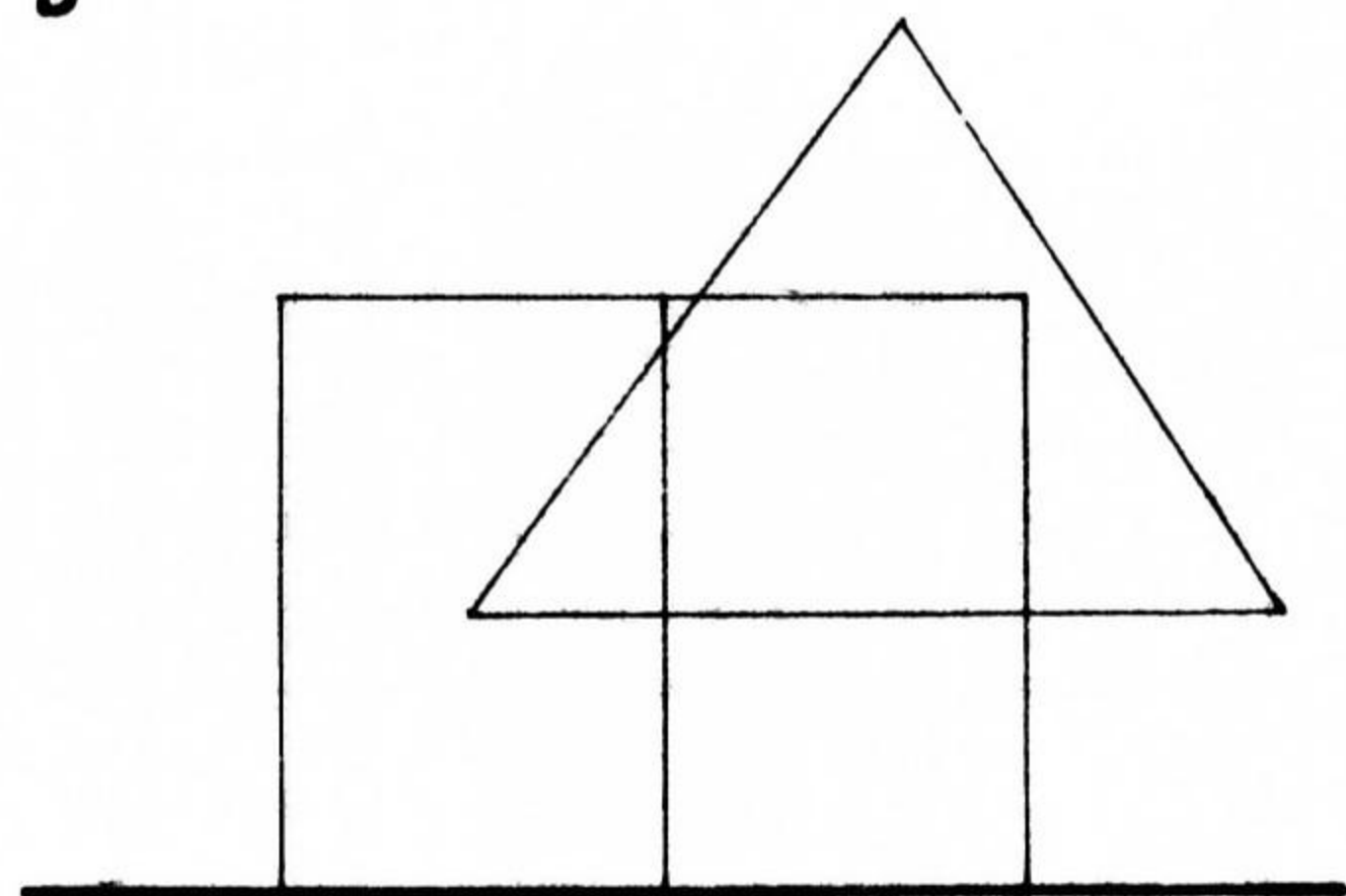

DPTO. DISEÑO BASICO

ISPJAE FACULTAD DE ARQUITECTURA

ASIGNATURA

TEMA

DOC.

ALUM.

No.

OPD.

FECHA

EVAL.



5.5.2 INTERSECCIONES – FIGURA PLANA CON POLIEDRO –VISIBILIDAD

E

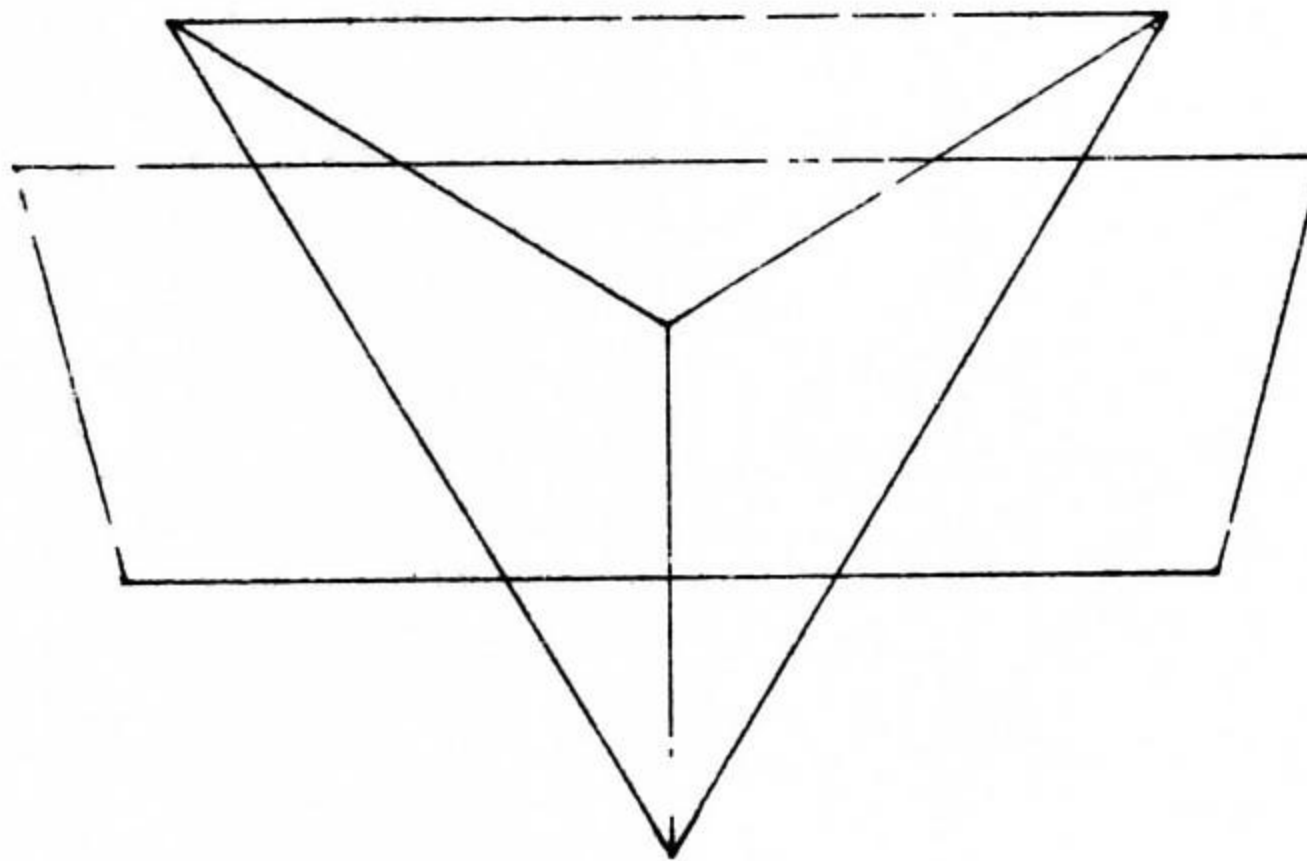
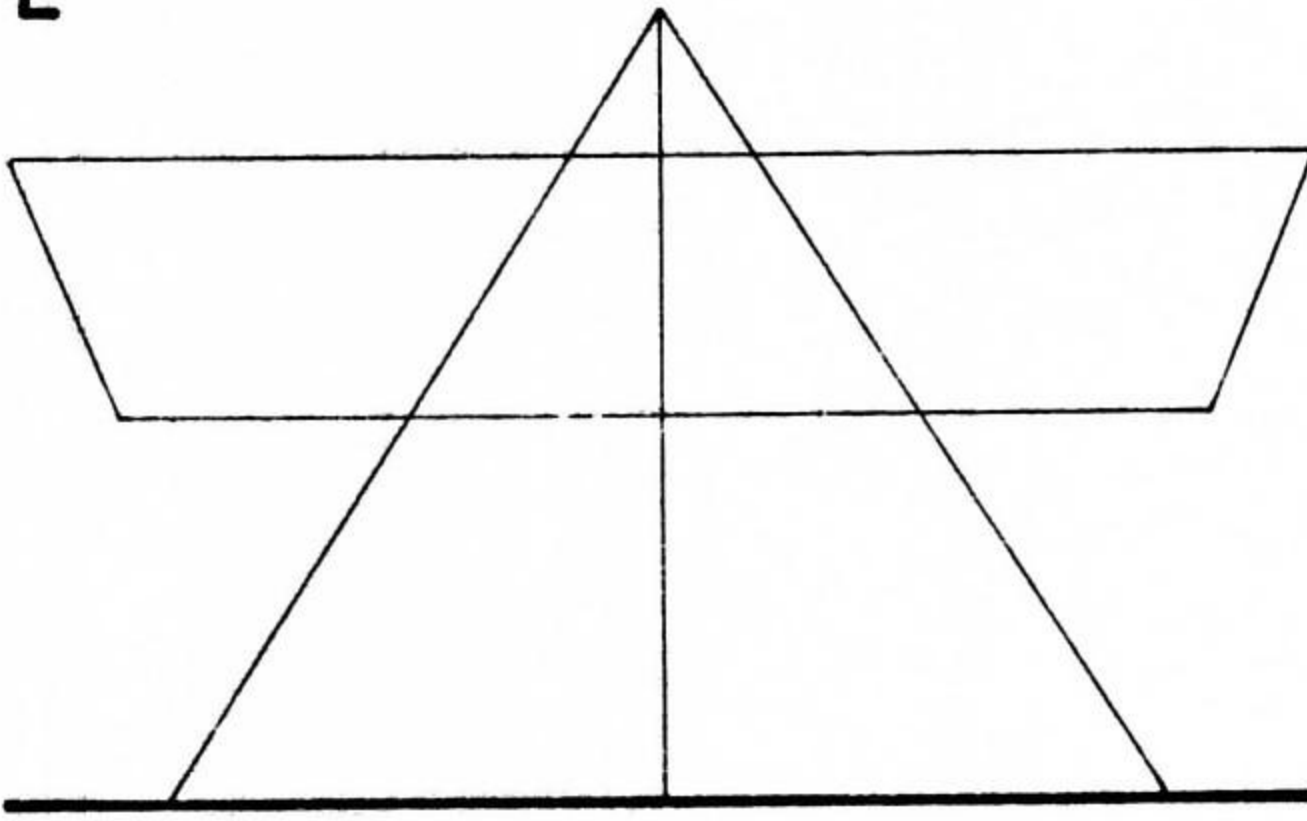

F

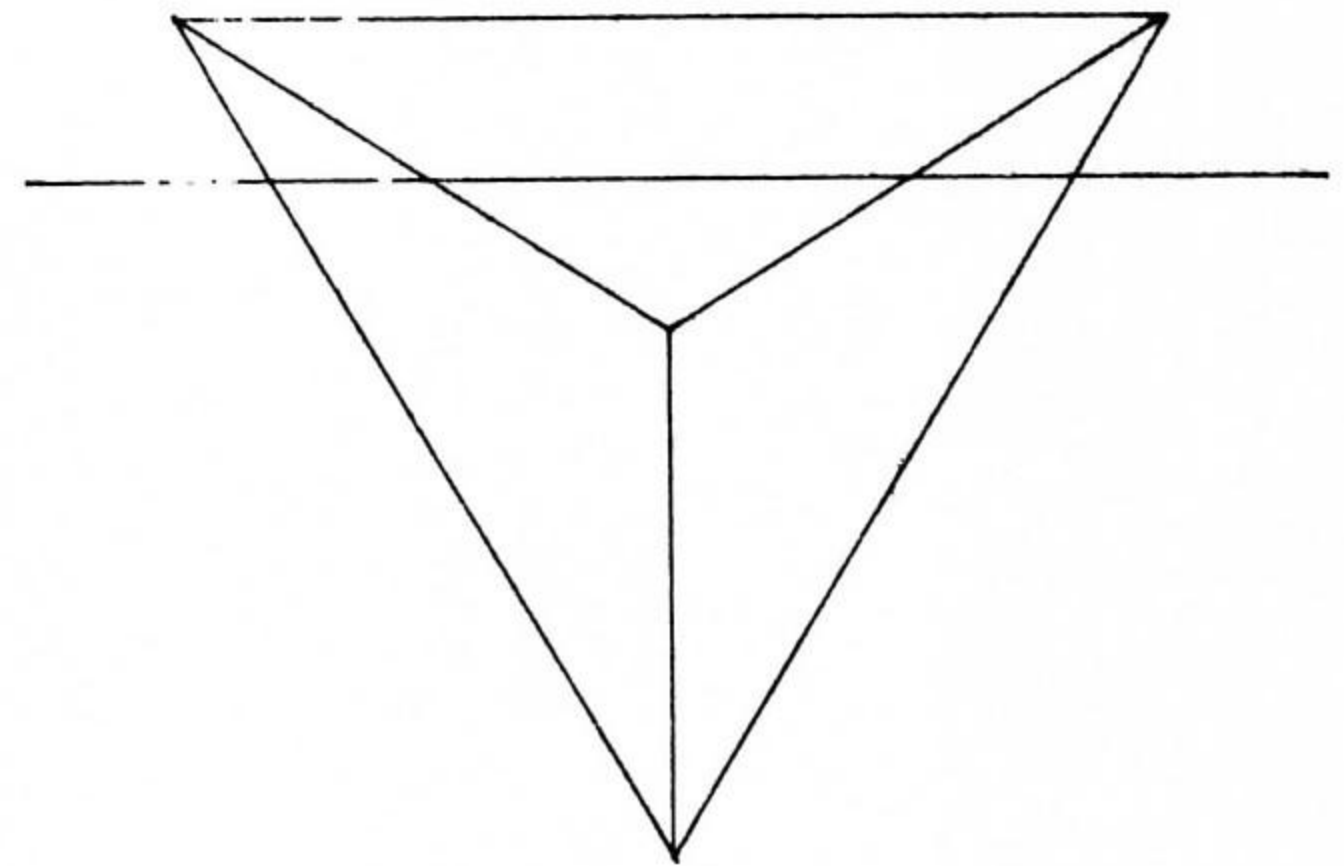
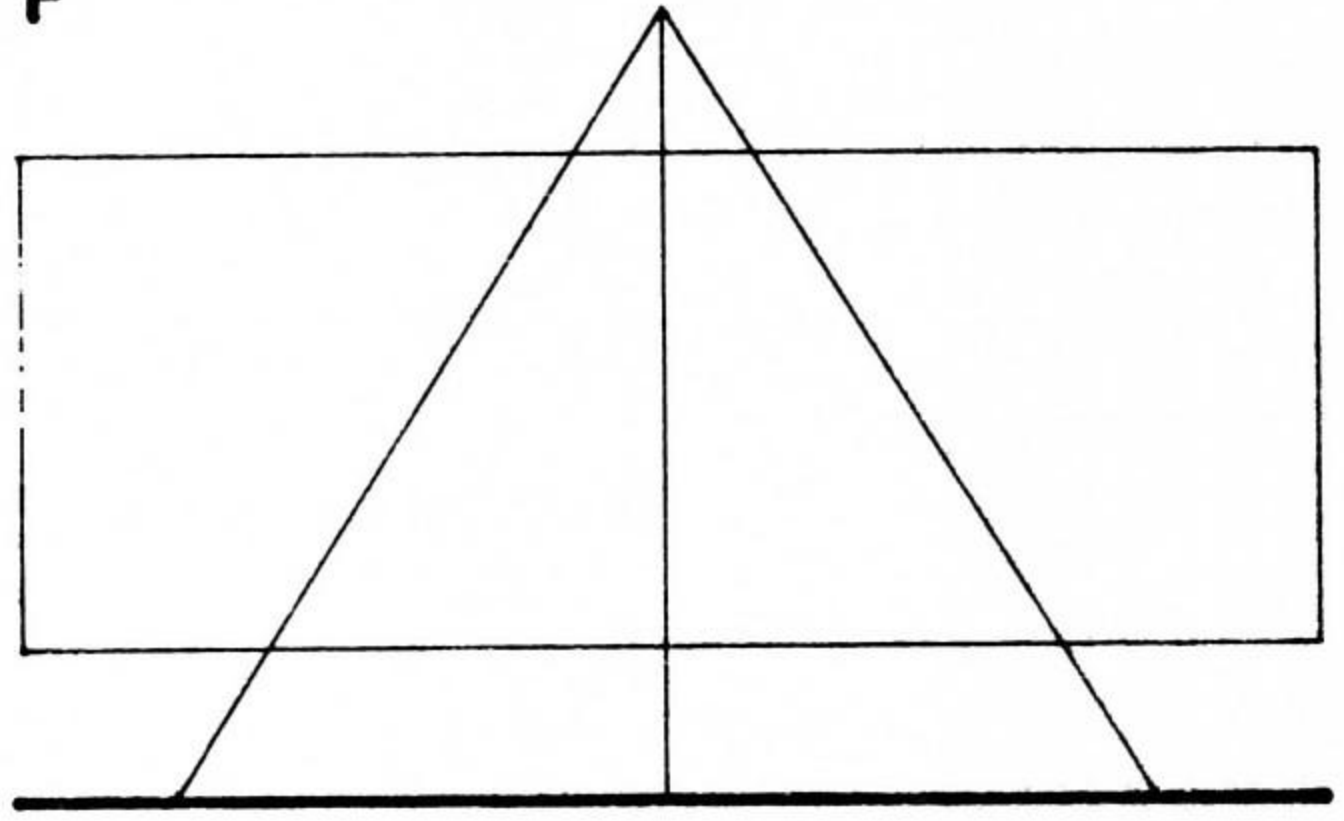

G

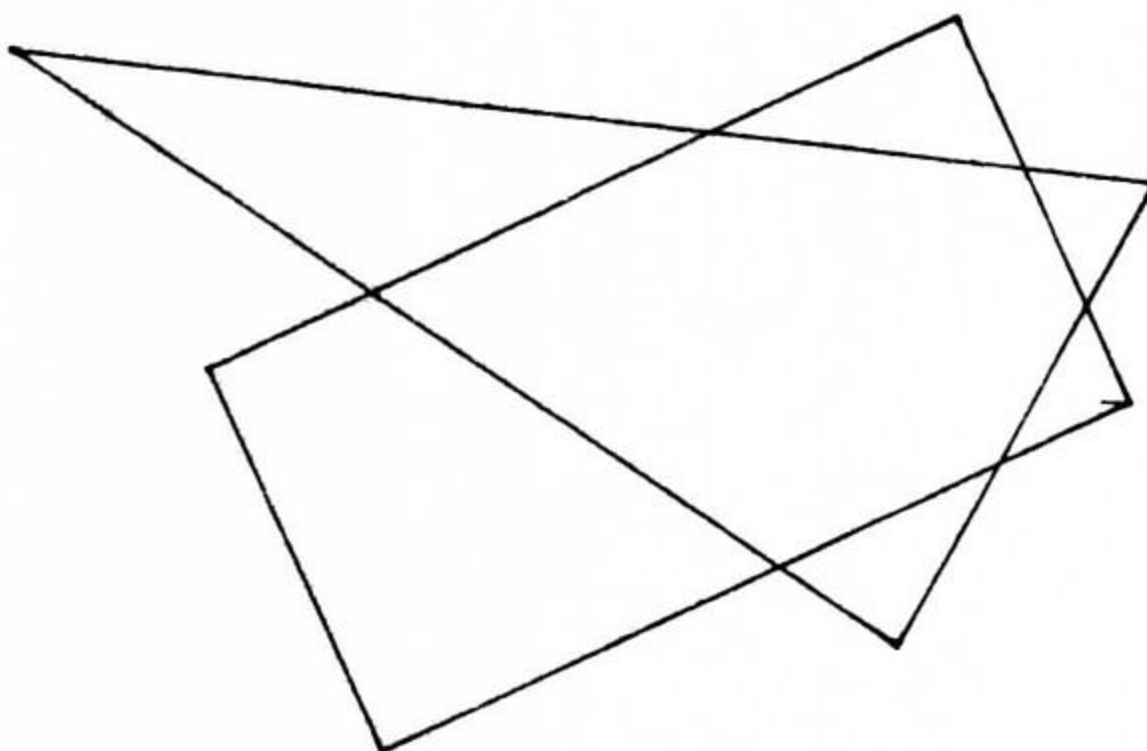
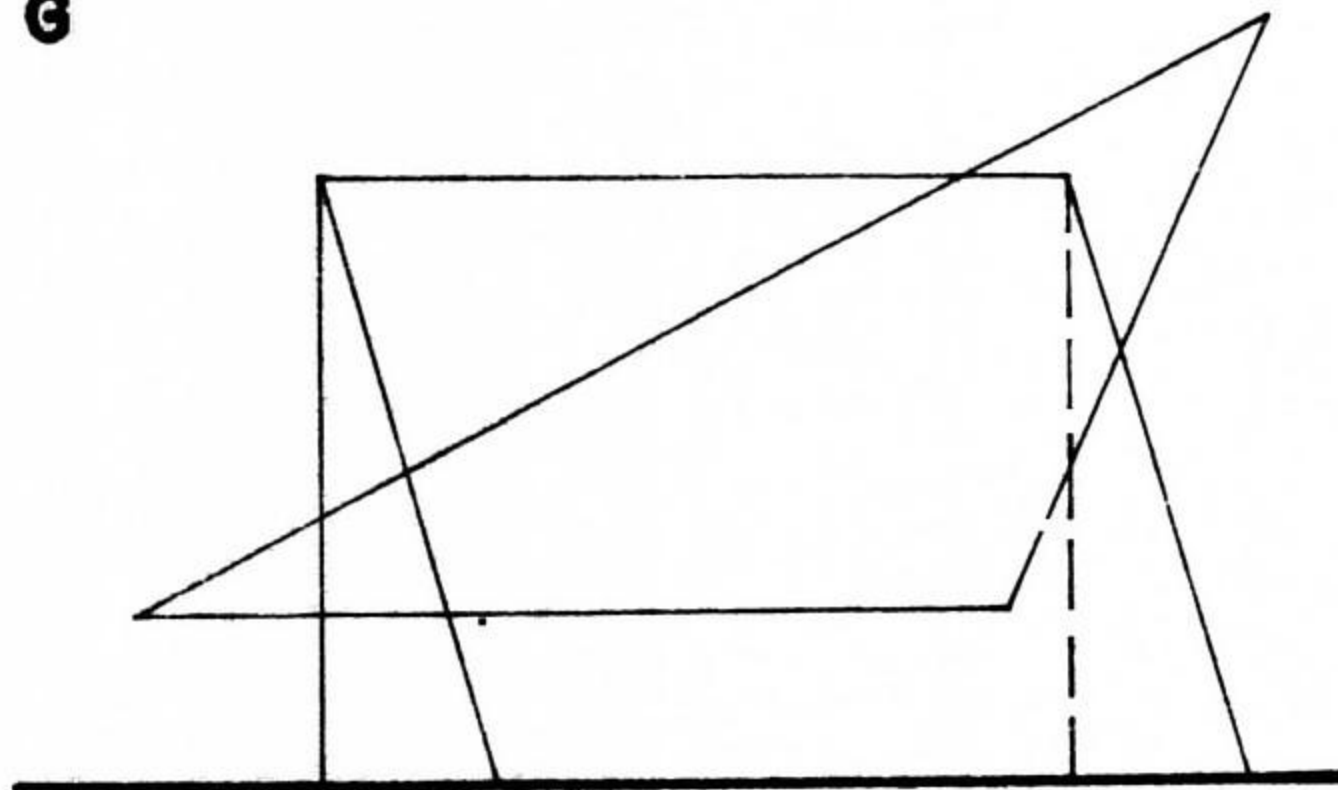

H

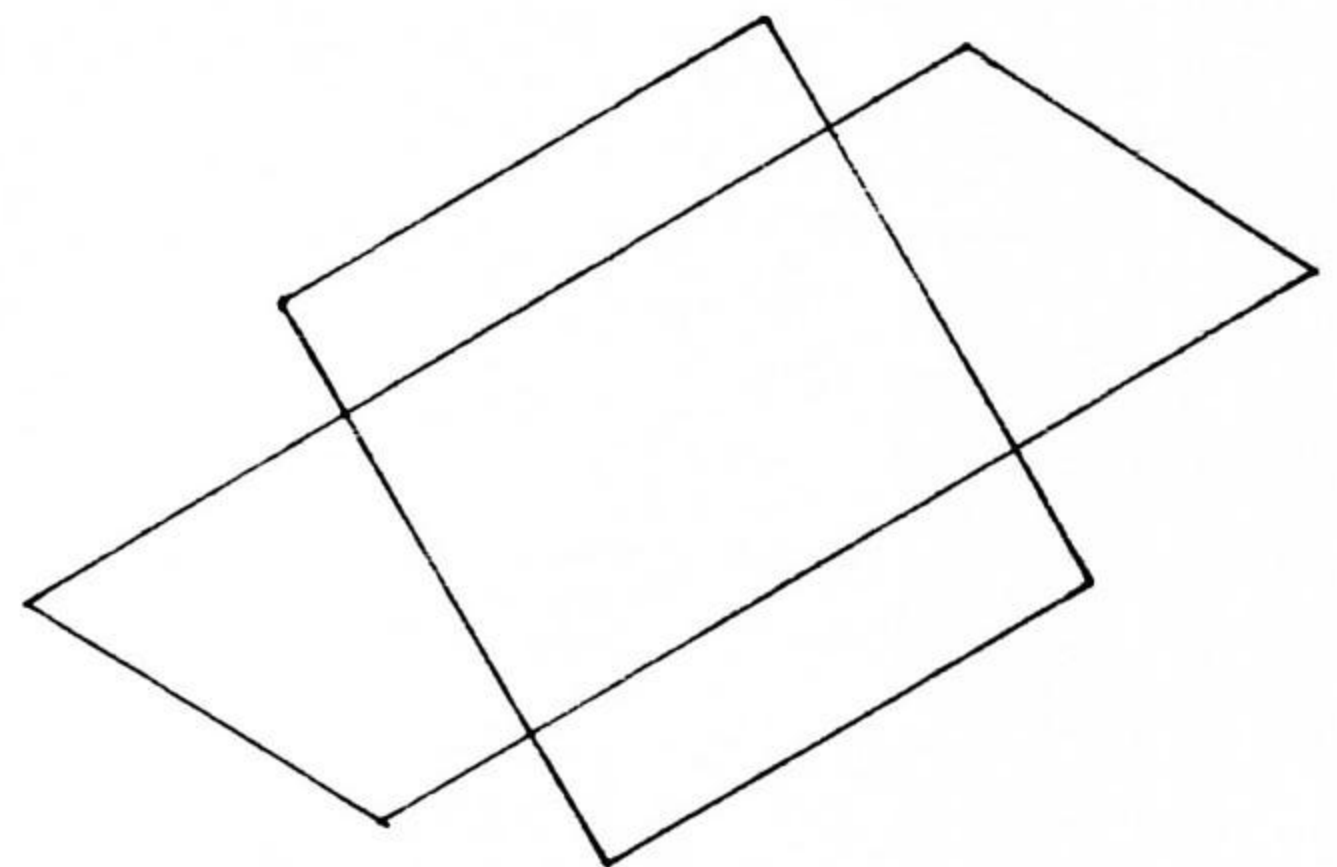
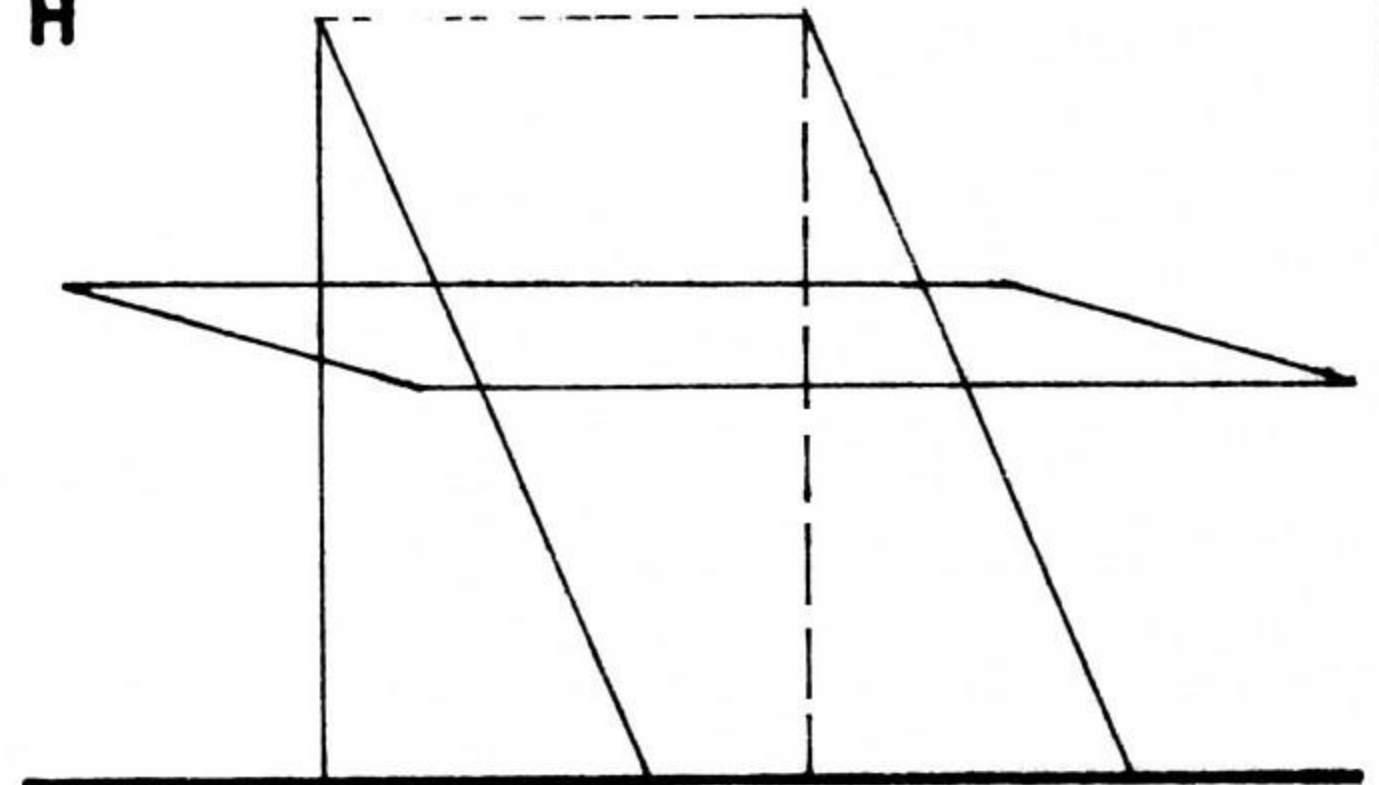

DPTO. DISEÑO BASICO

**ISPJAE
FACULTAD DE ARQUITECTURA**

ASIGNATURA

TENA

DOC.

ALUM.

No.

GRUPO.

FECHA

EVAL.



5.5.2 INTERSECCIONES DE POLIEDROS ANALISIS Y SINTESIS.

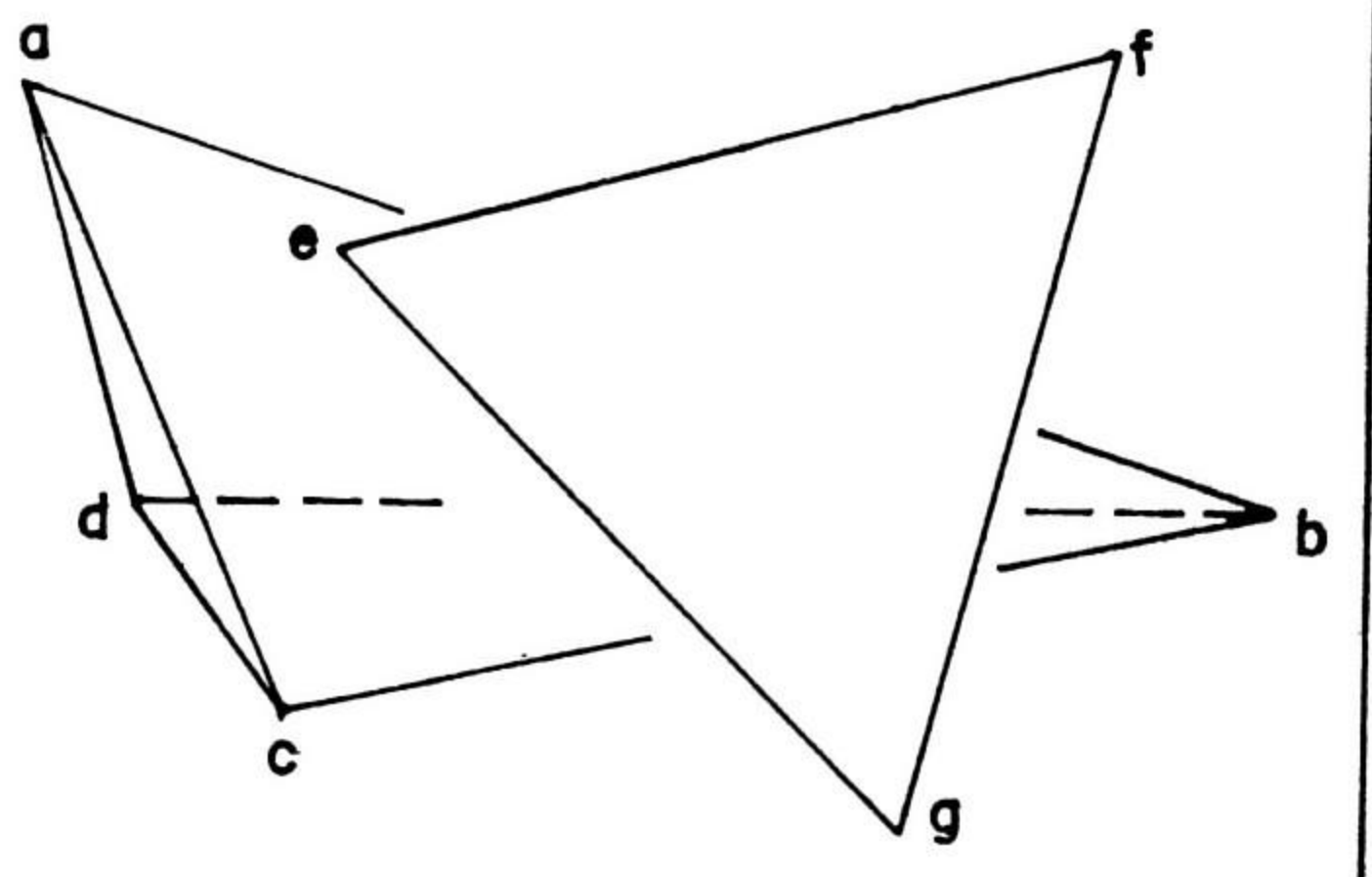
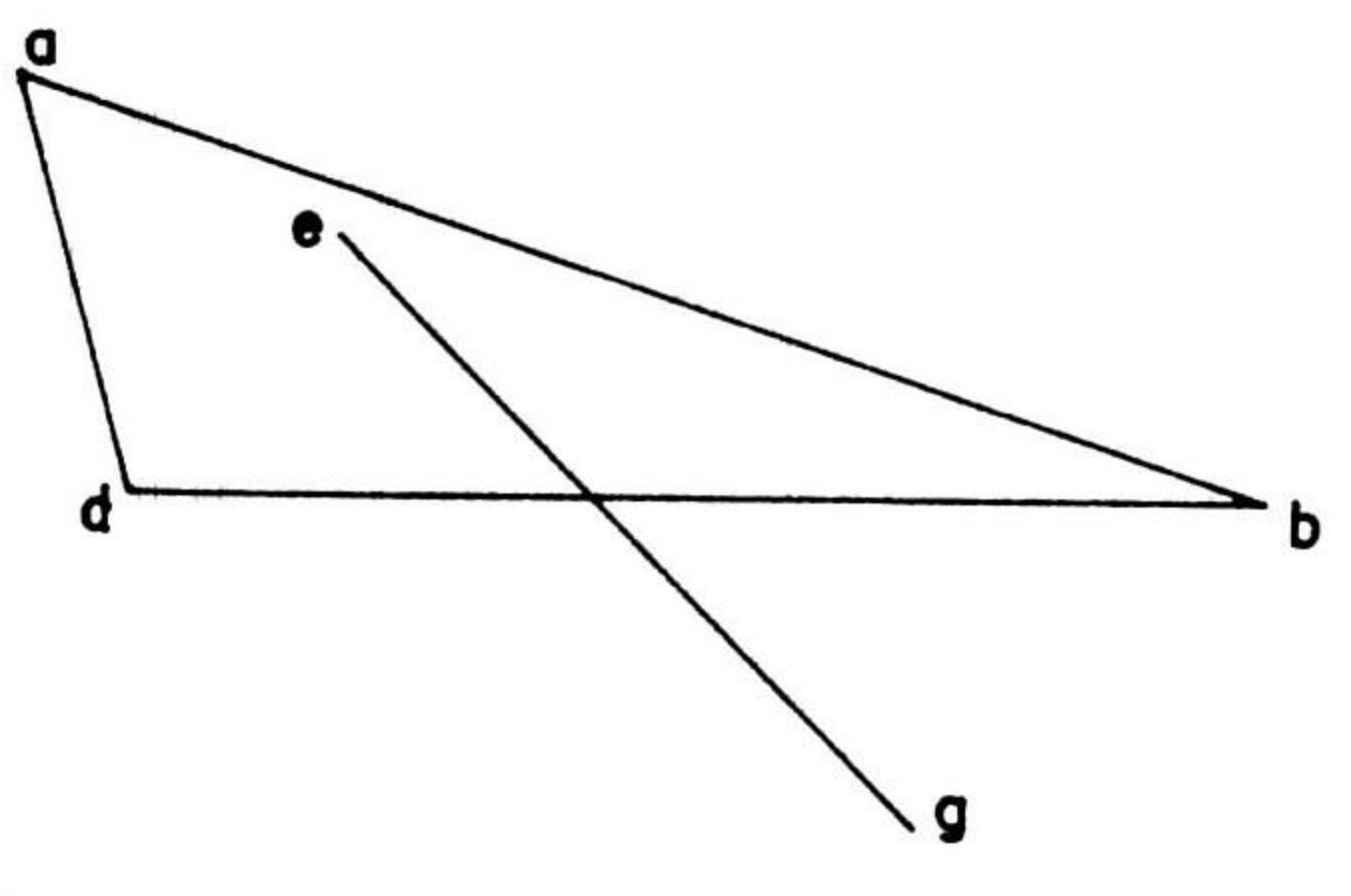
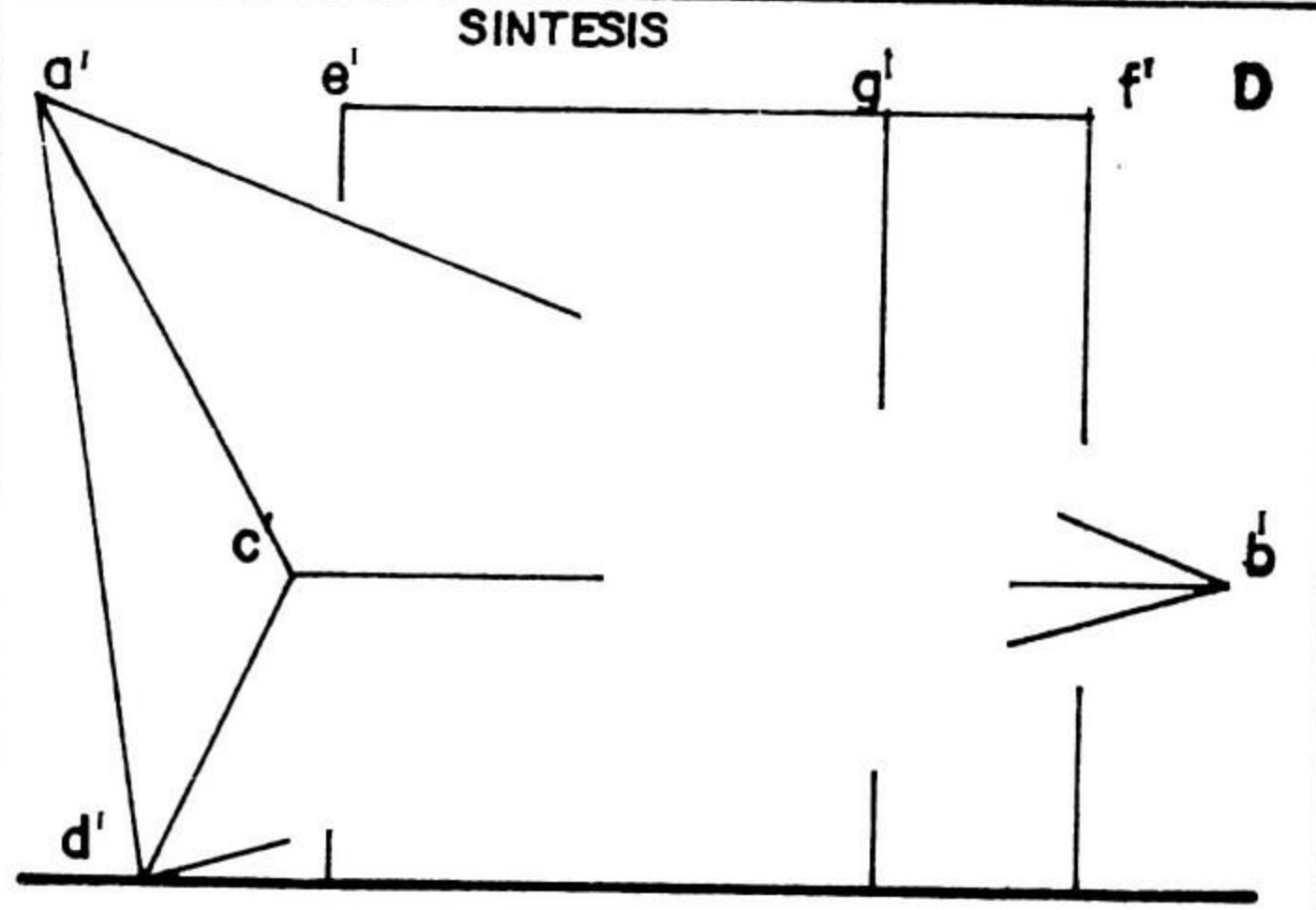
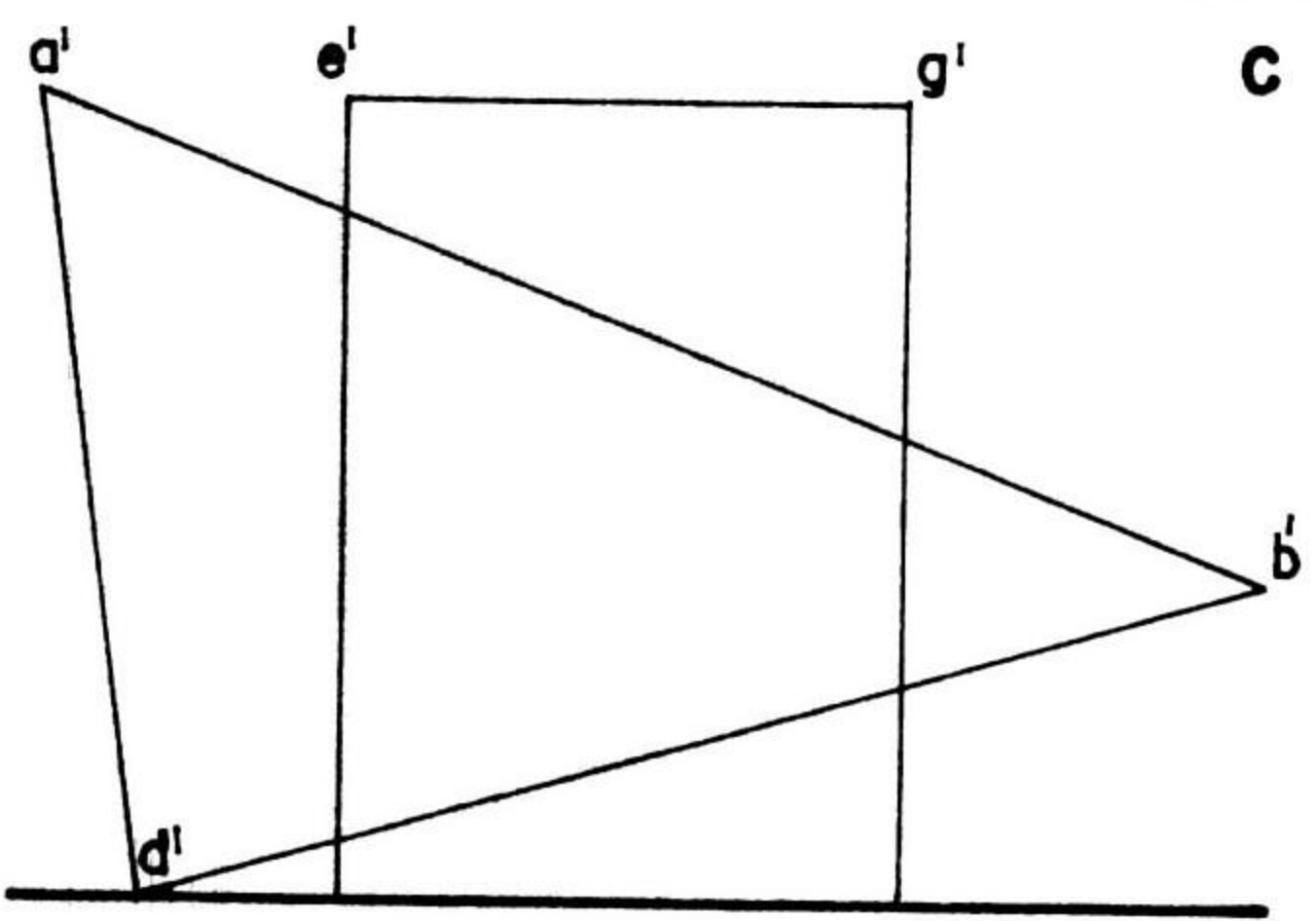
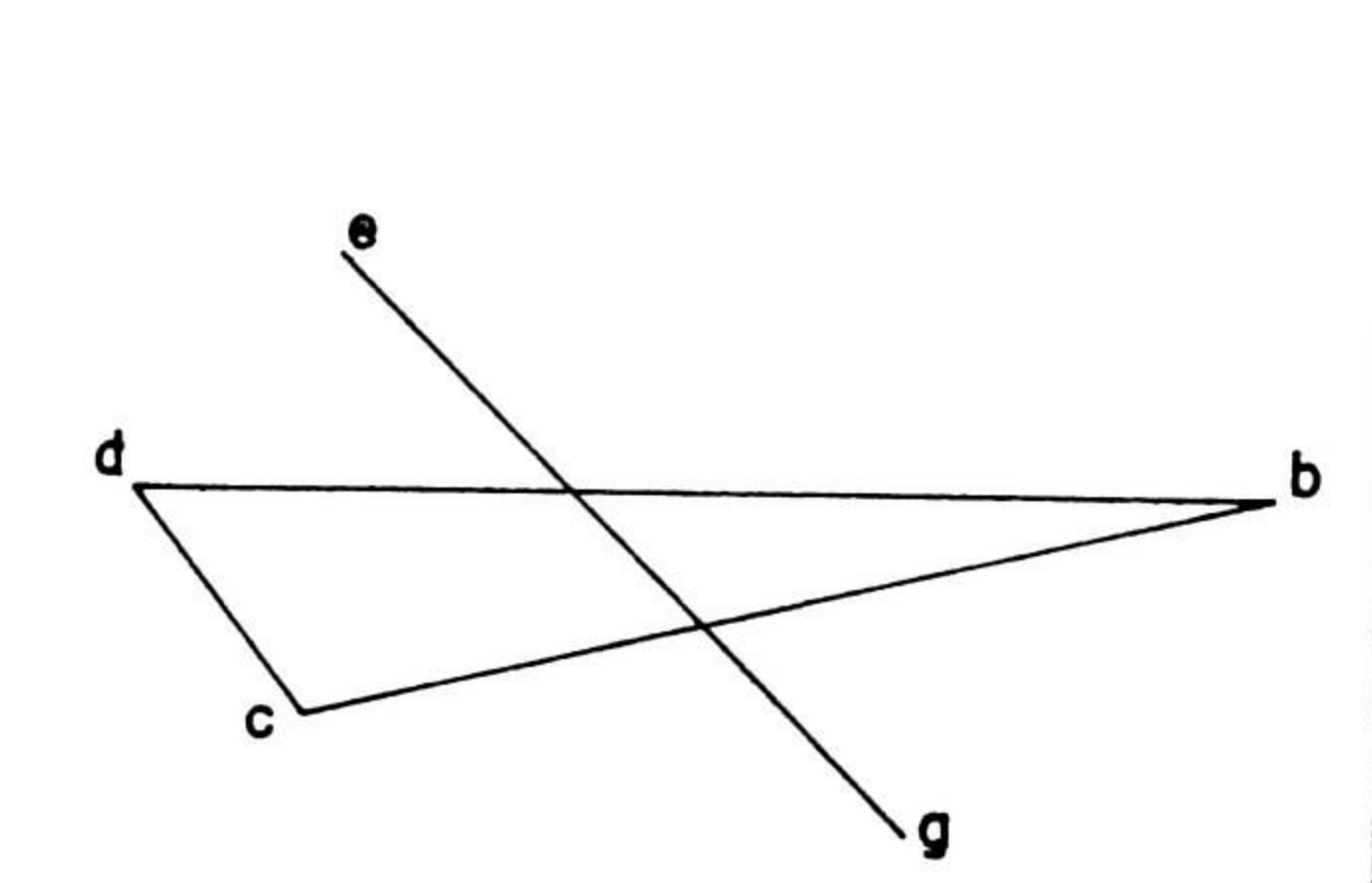
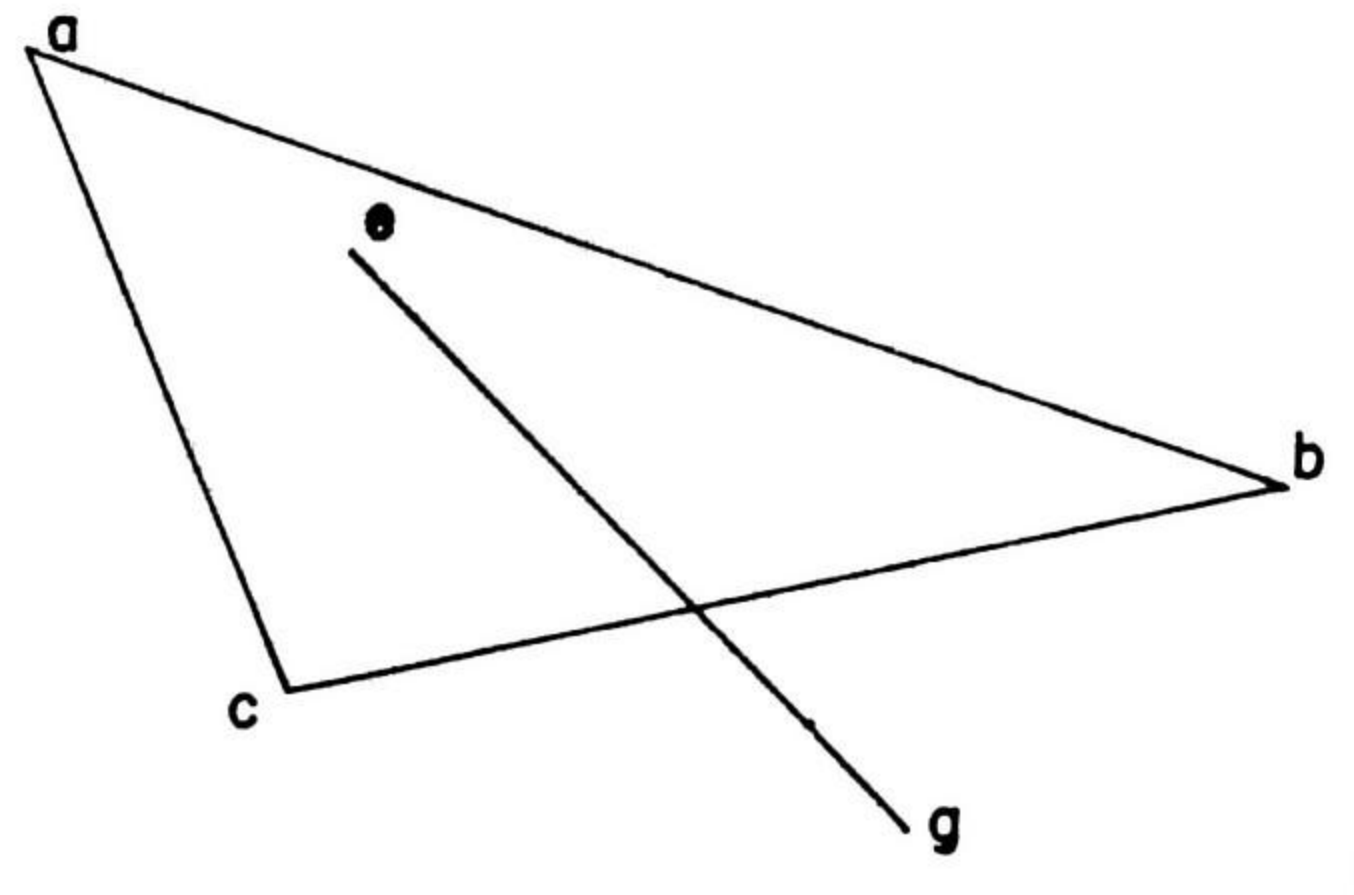
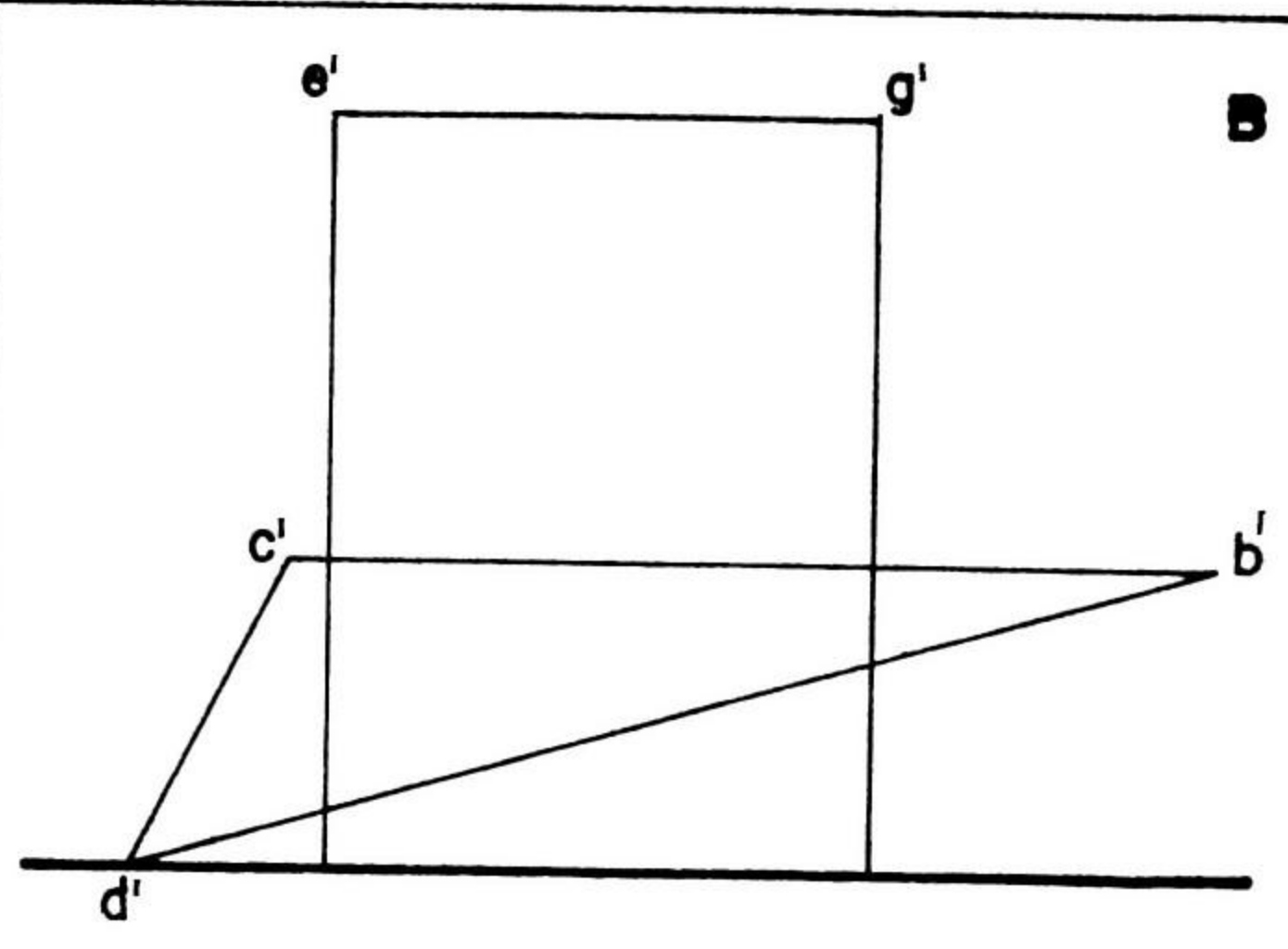
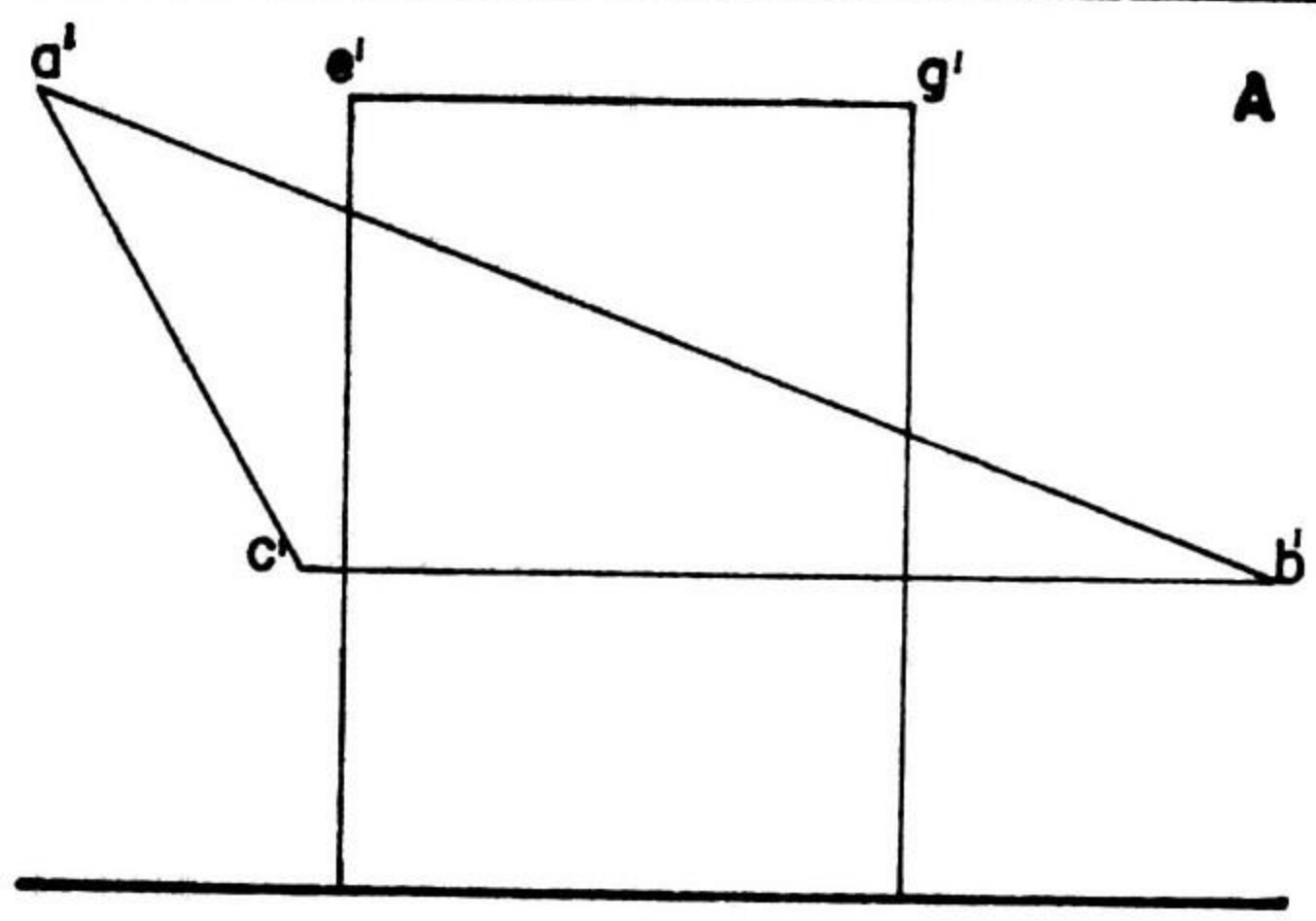

DPTO. DISEÑO BASICO

ISPJAE FACULTAD DE ARQUITECTURA

ASIGNATURA	TEMA			D D D	
DOC.	ALUM.		No.		OPD.
FECHA			EVAL.		

5.5.2 DETERMINAR LAS INTERSECCIONES

A

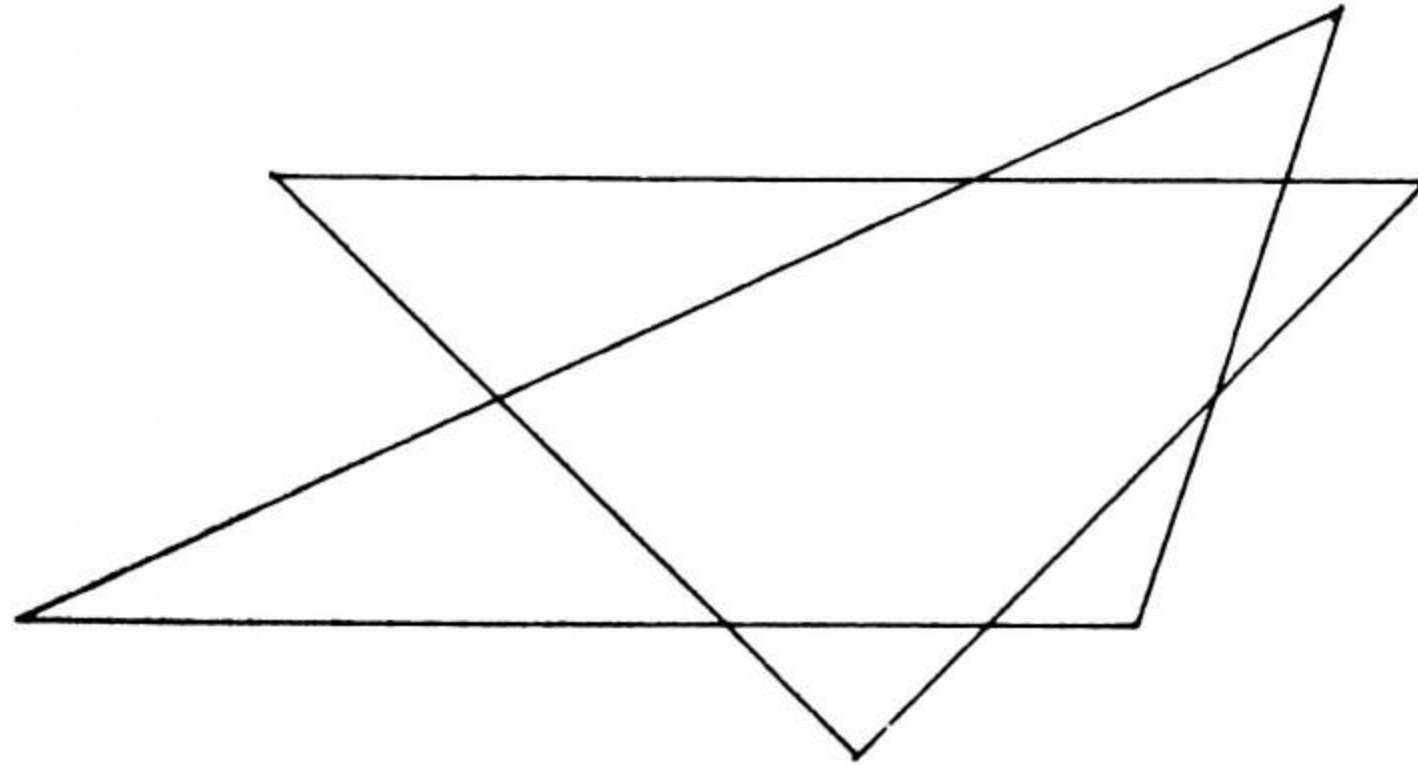
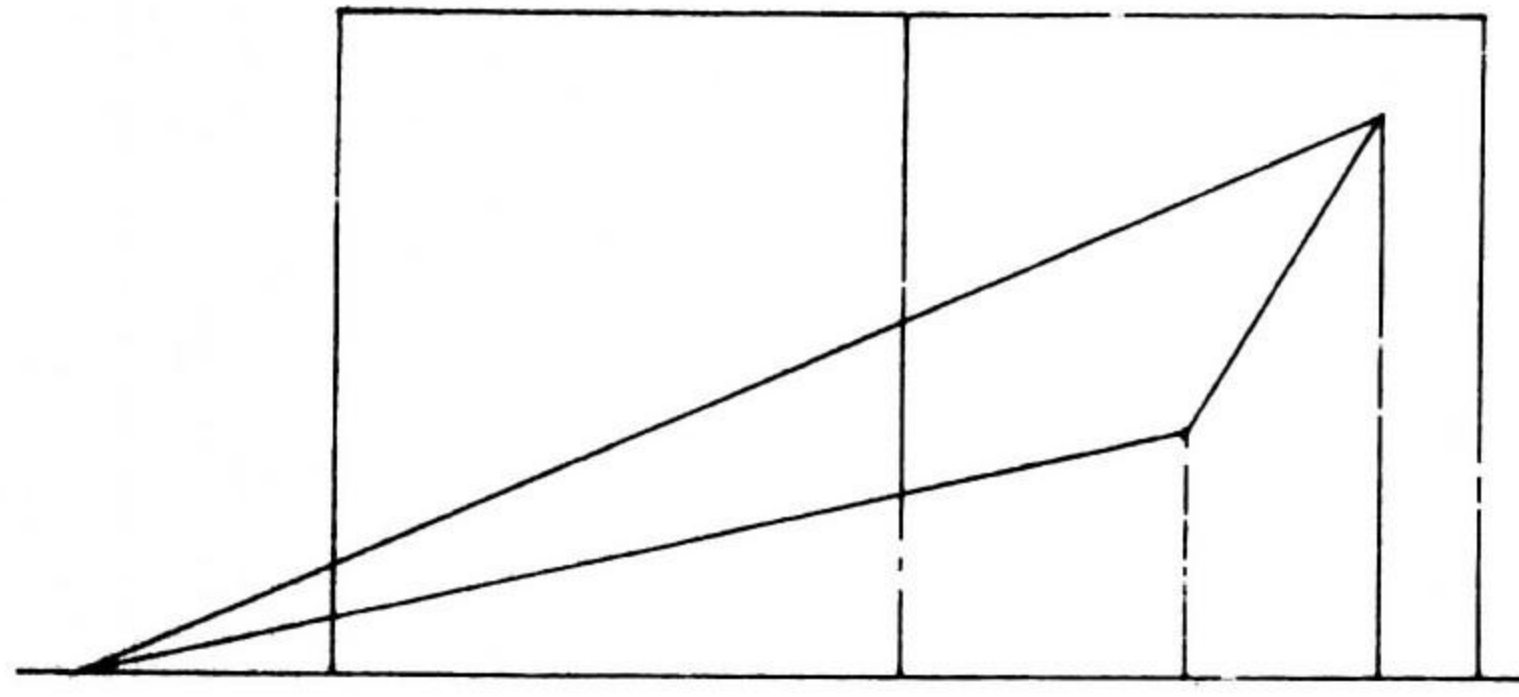

B

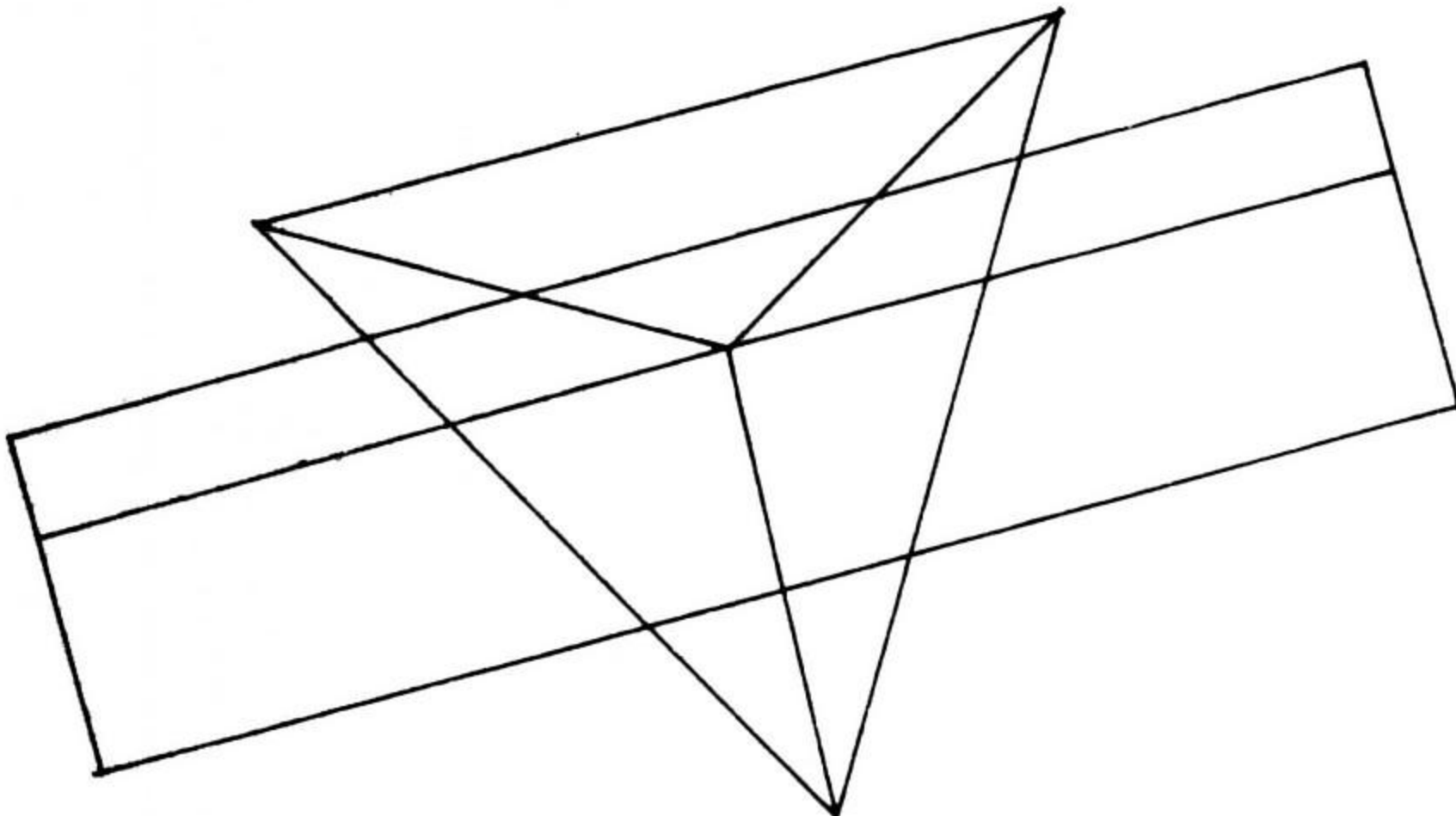
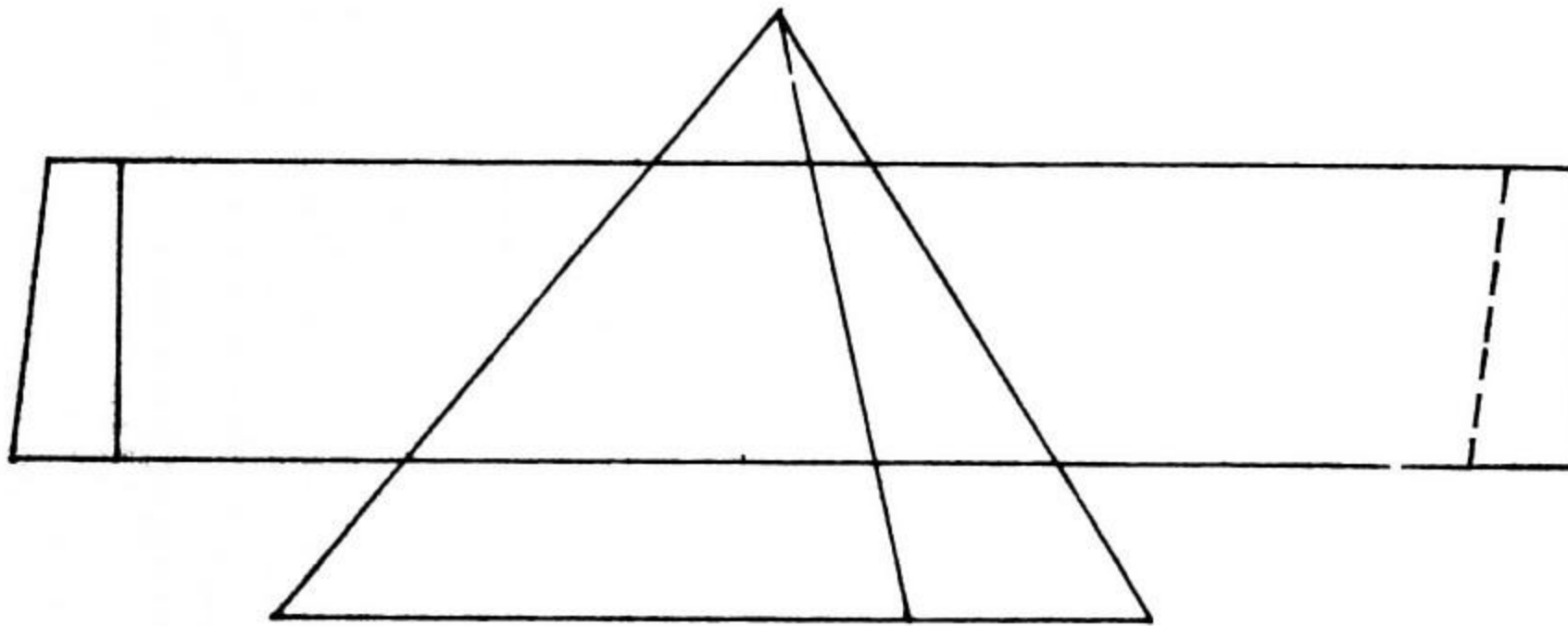

DPTO. DISEÑO BASICO

**ISPJAE
FACULTAD DE ARQUITECTURA**

ASIGNATURA

TEMA

DOC.

ALUM.

No.

GRPO.

FECHA

EVAL.



5.5.2 INTERSECCIONES DE POLIEDROS: PRISMAS

Construir la huella que deja el prisma ABCDEF en el otro prisma.

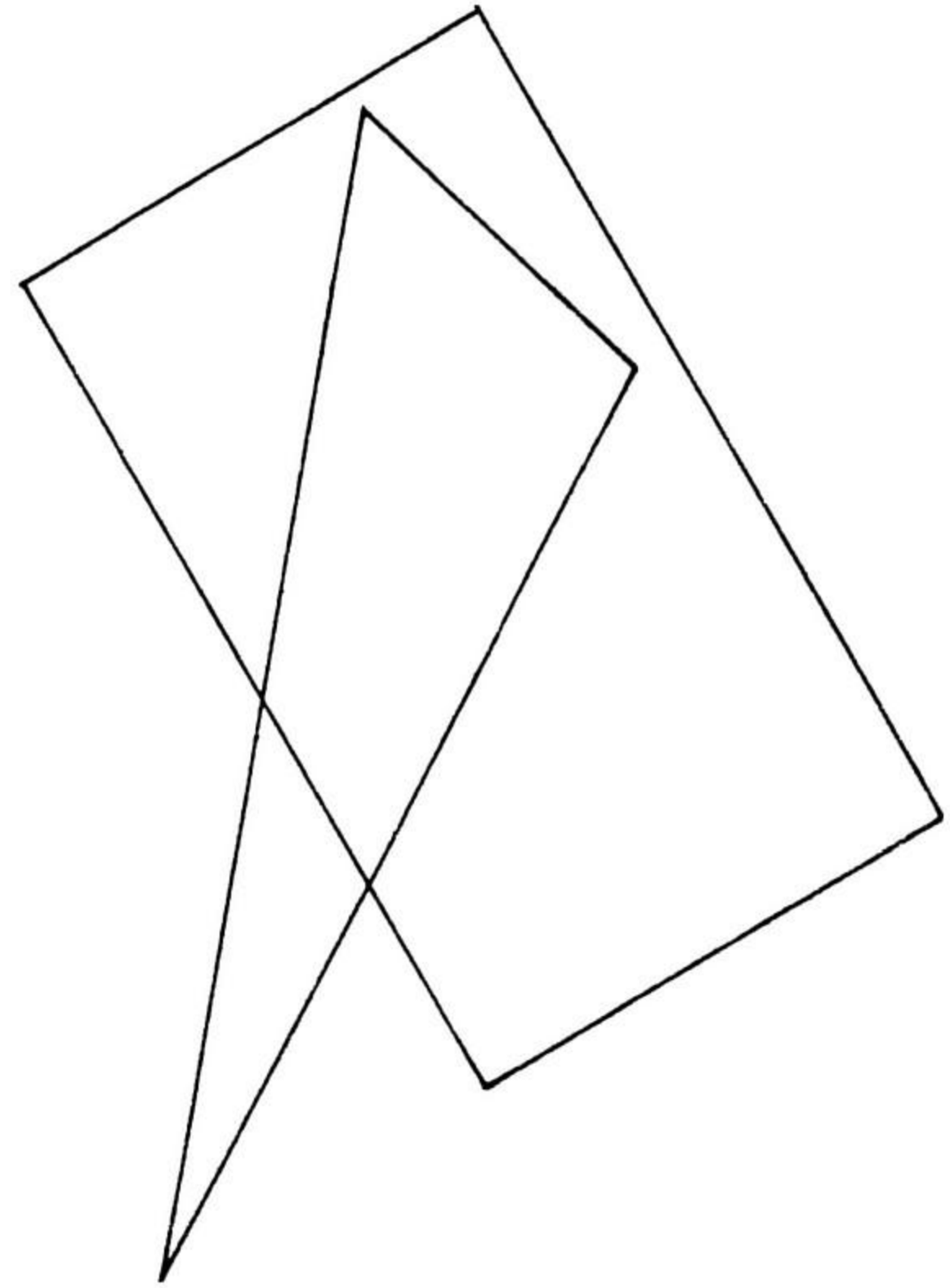
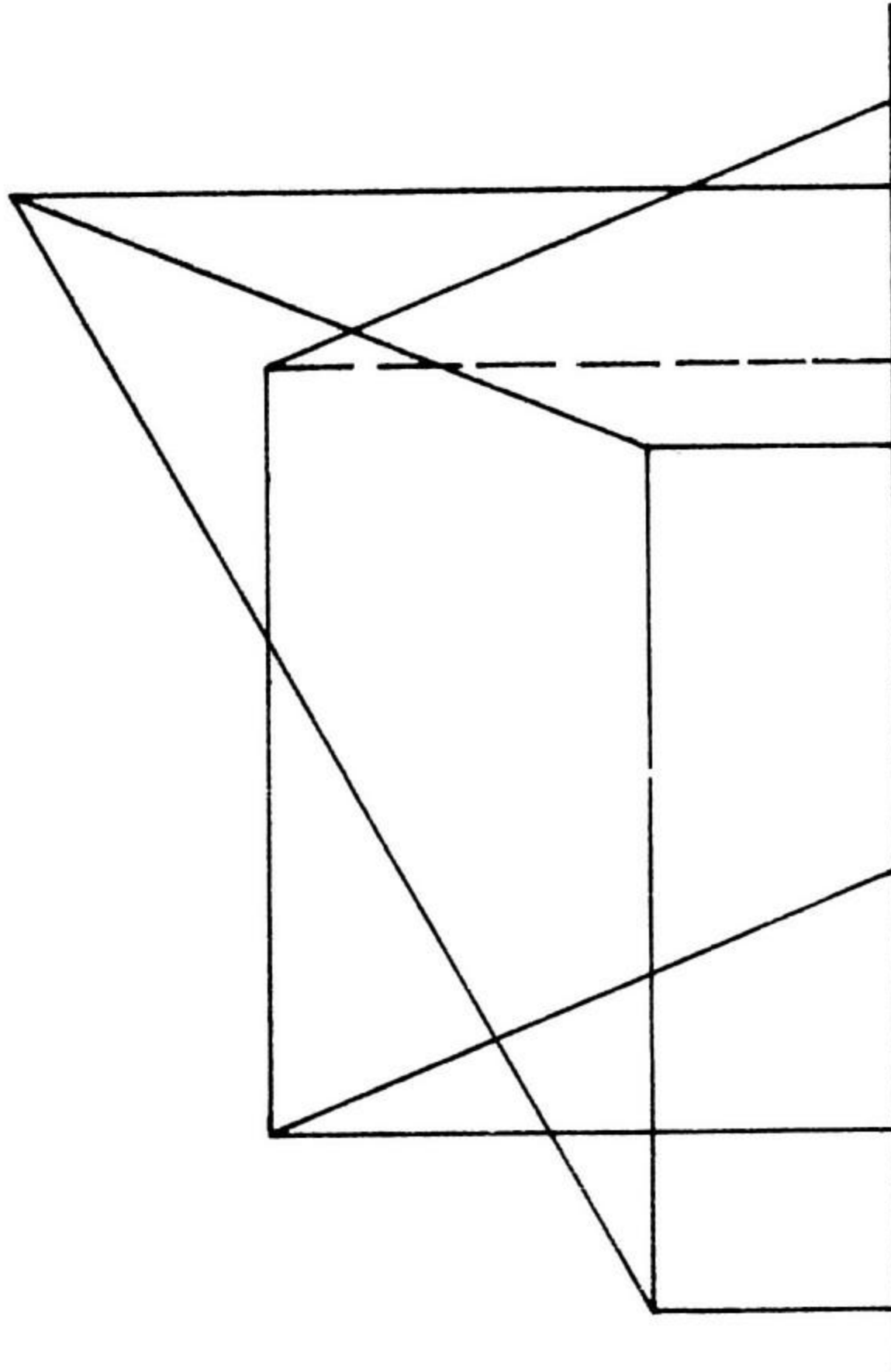

A Determinar las intersecciones de los dos poliedros.. Considerar homogéneo el poliedro resultante. Determinar la visibilidad.

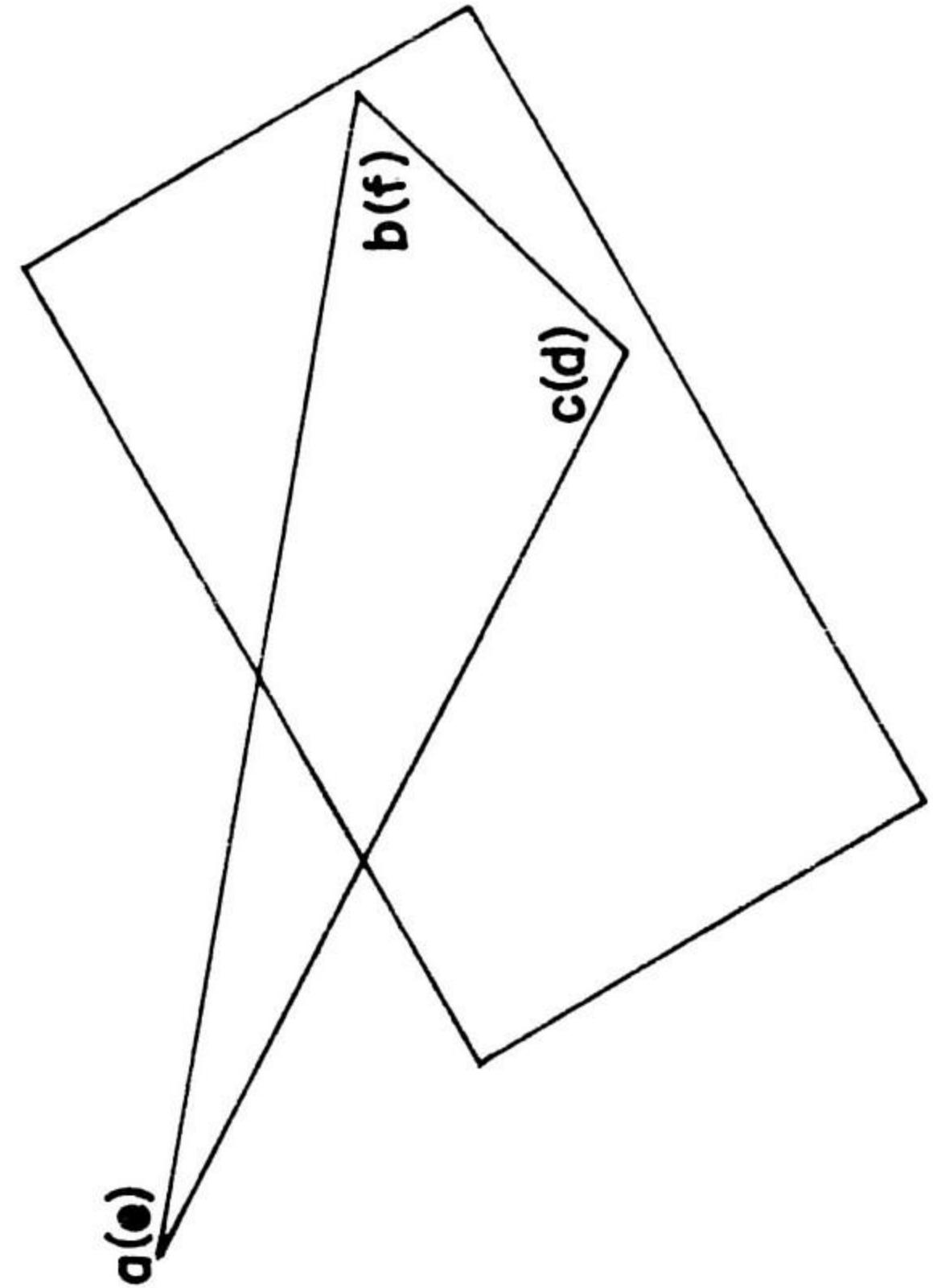
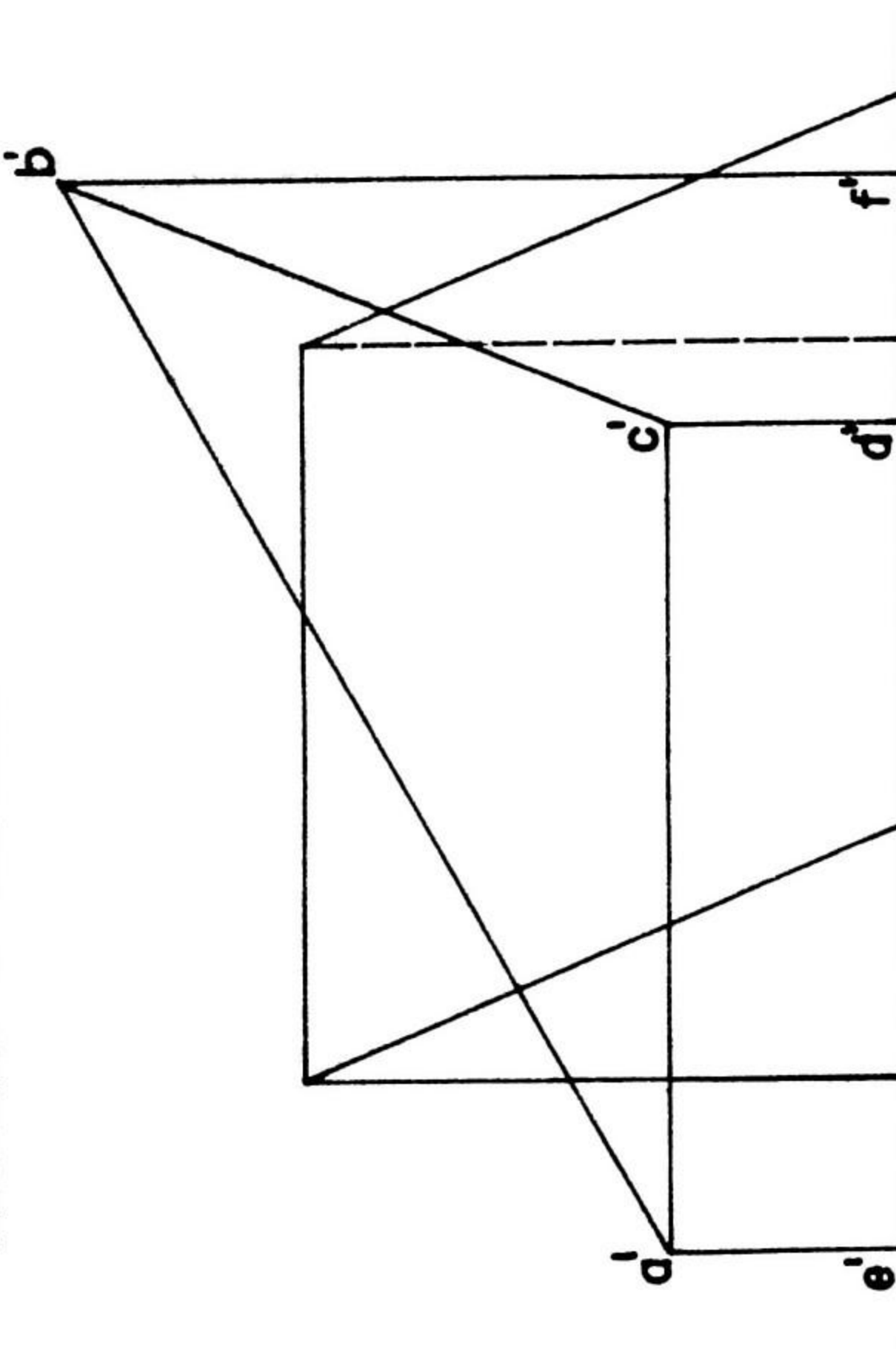

DPTO. DISEÑO BASICO

ISPJAE FACULTAD DE ARQUITECTURA

SIGNATURA	TEMA		
DOC.	ALUM.	No.	OPQ.
FECHA		EVAL.	

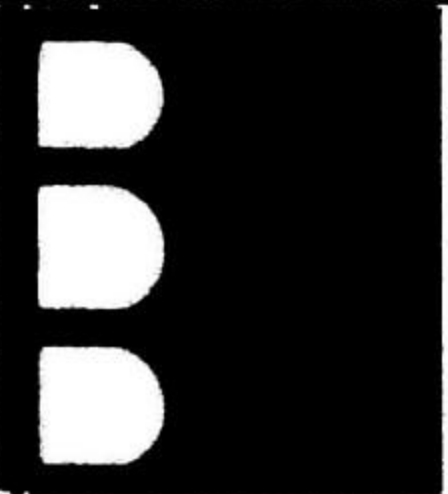

5.5.2 INTERSECCIONES DE POLIEDROS : PRISMA Y PIRAMIDE

Construir la huella que deja la pirámide en el prisma.

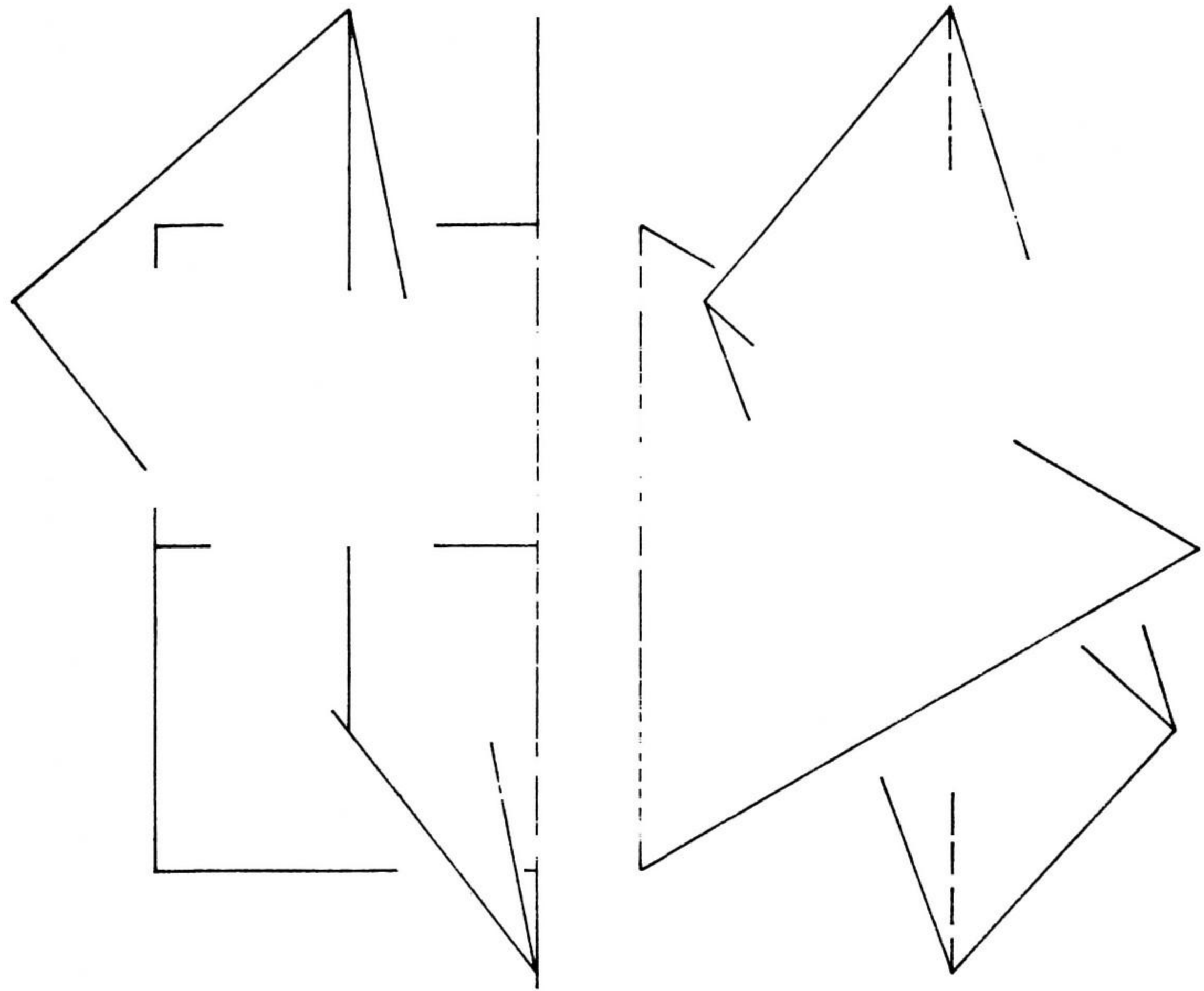

Determinar las intersecciones de los dos poliedros.
 Considerar homogéneo el poliedro resultante.
 Determinar la visibilidad.

B

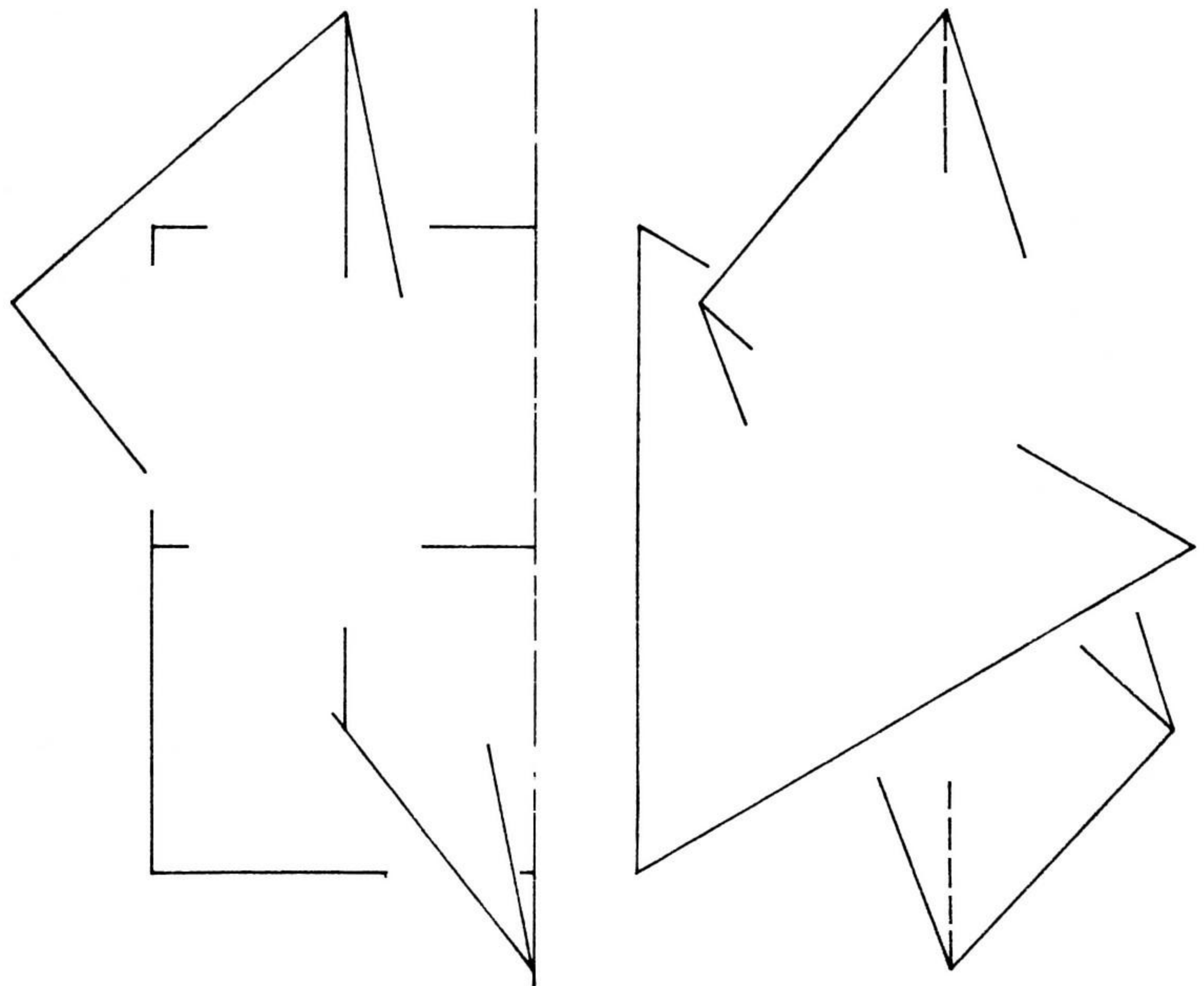

DPTO. DISEÑO BASICO

ISPJAE FACULTAD DE ARQUITECTURA

ASIGNATURA

TEMA

DOC.

ALUM.

No.

GRUPO

FECHA

EVAL.

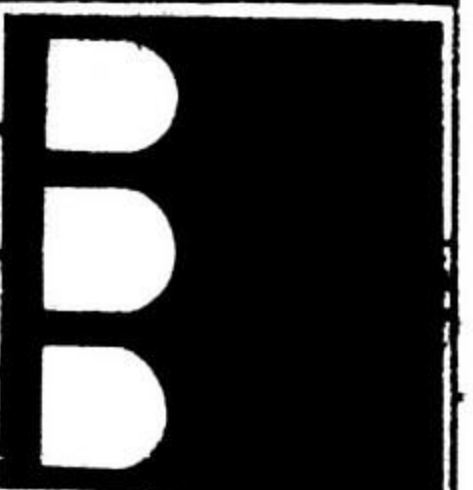

5.5.2 INTERSECCIONES DE POLIEDROS: PRISMA Y PIRAMIDE

Construir la huella que deja el prisma en la pirámide

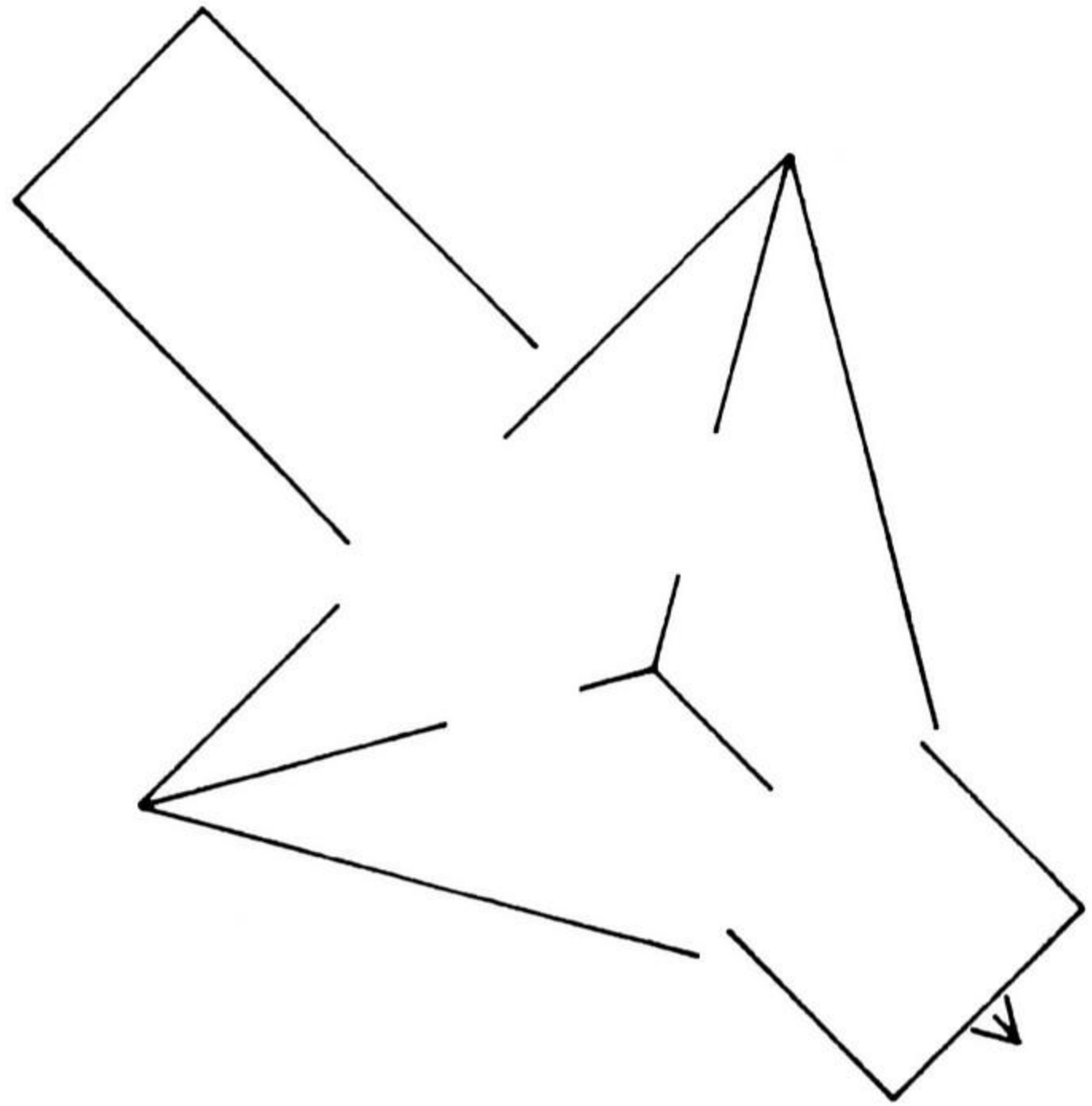
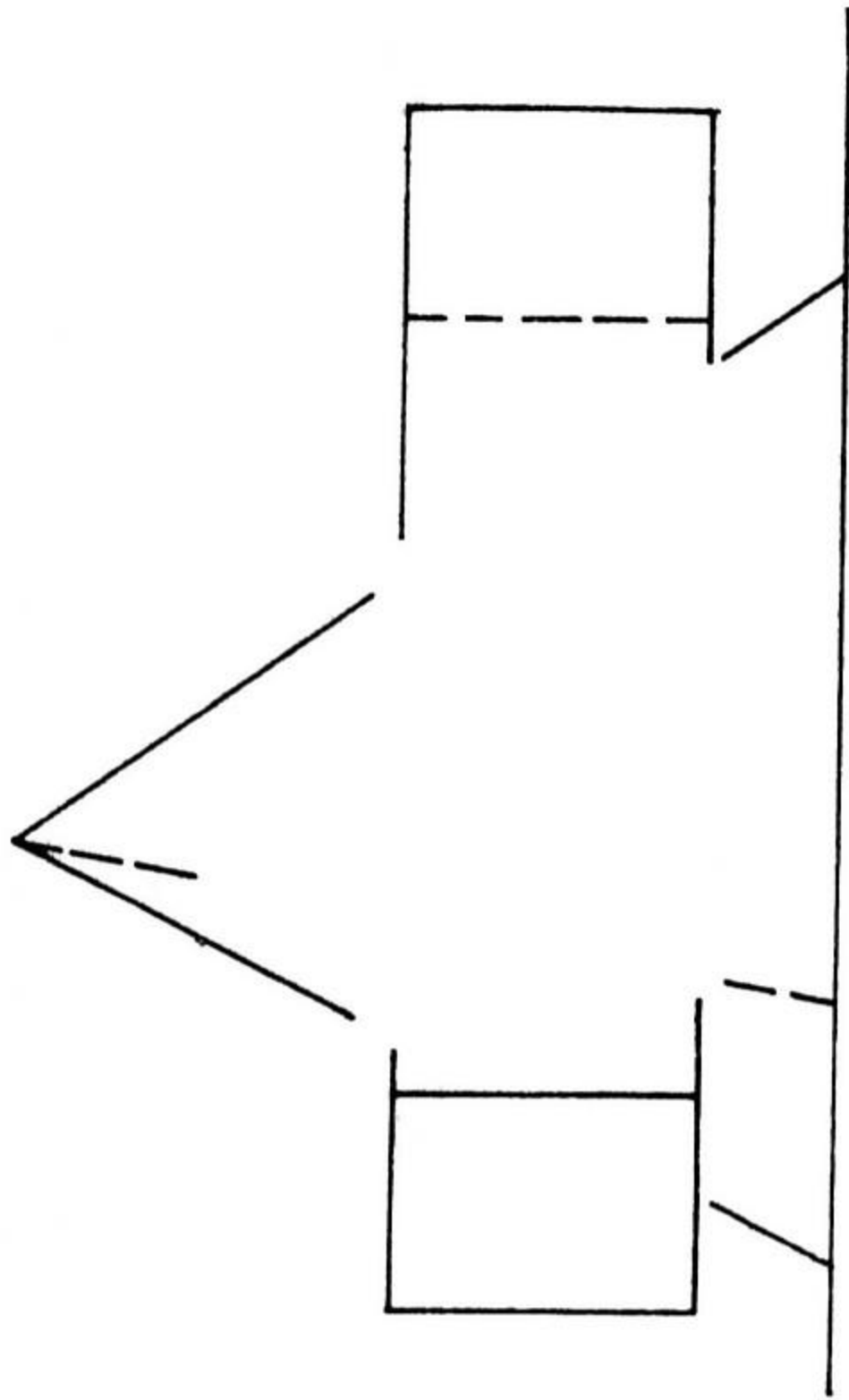

Determinar las intersecciones de los dos poliedros.
Considerar homogéneo el poliedro resultante.
Determinar la visibilidad.

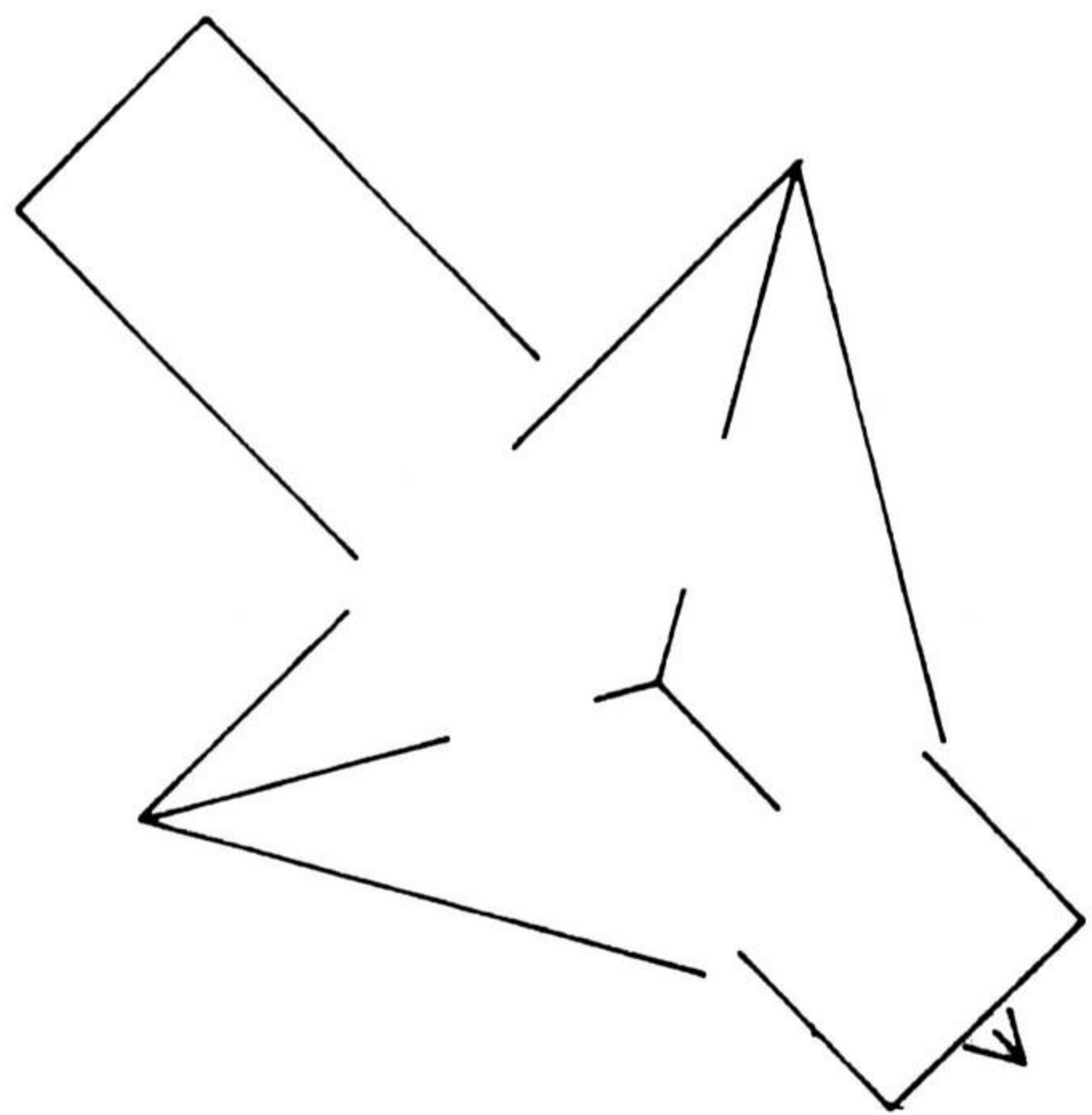
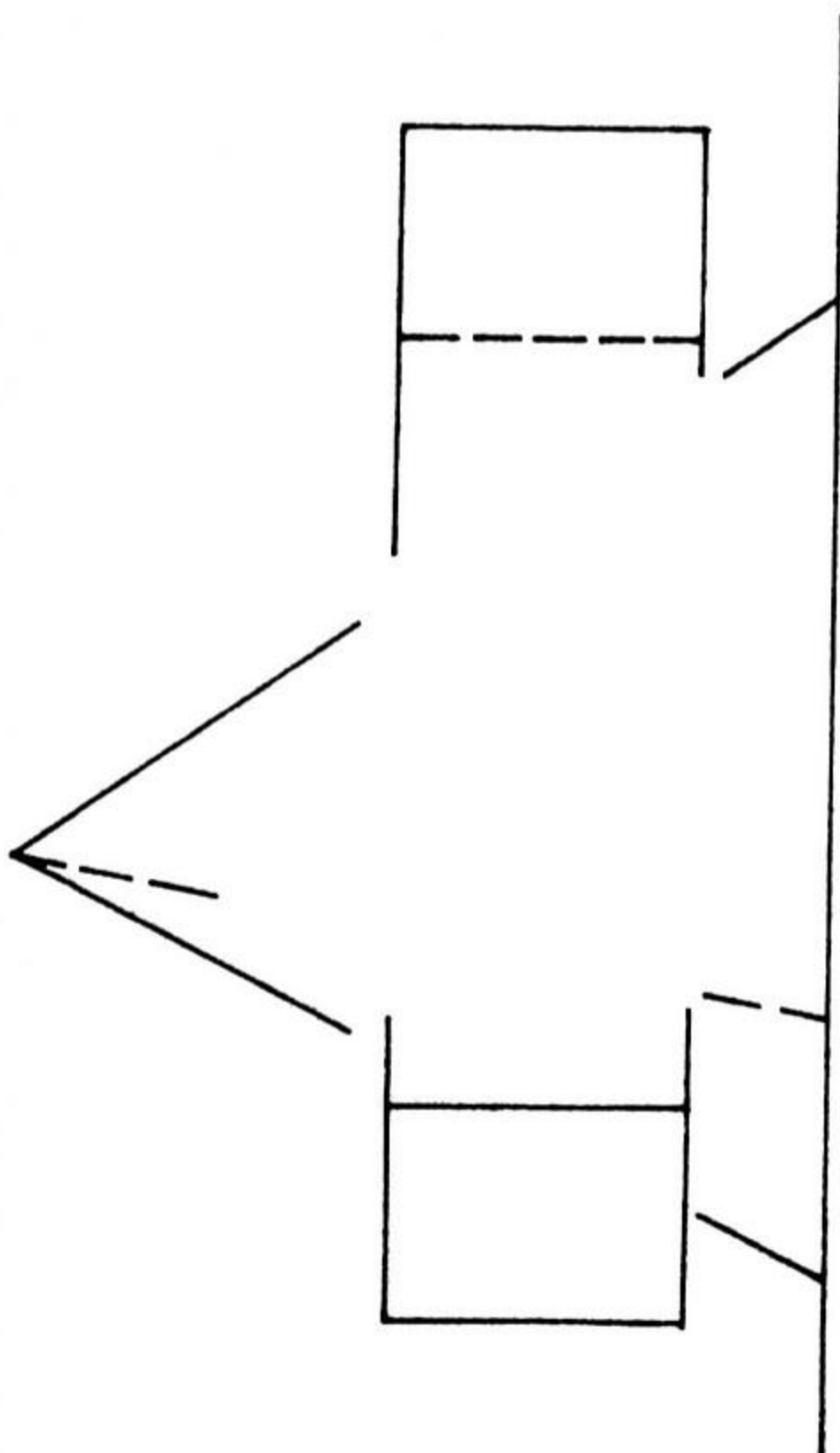

C

DPTO. DISEÑO BASICO

ISPJAE
FACULTAD DE ARQUITECTURA

ASIGNATURA	TENA			D D D
DOC.	ALUM.	No.	EPO.	
FECHA			EVAL.	

5.5.2 INTERSECCIONES DE POLIEDROS: PRISMAS

Construir la huella que deja el prisma horizontal en el vertical.

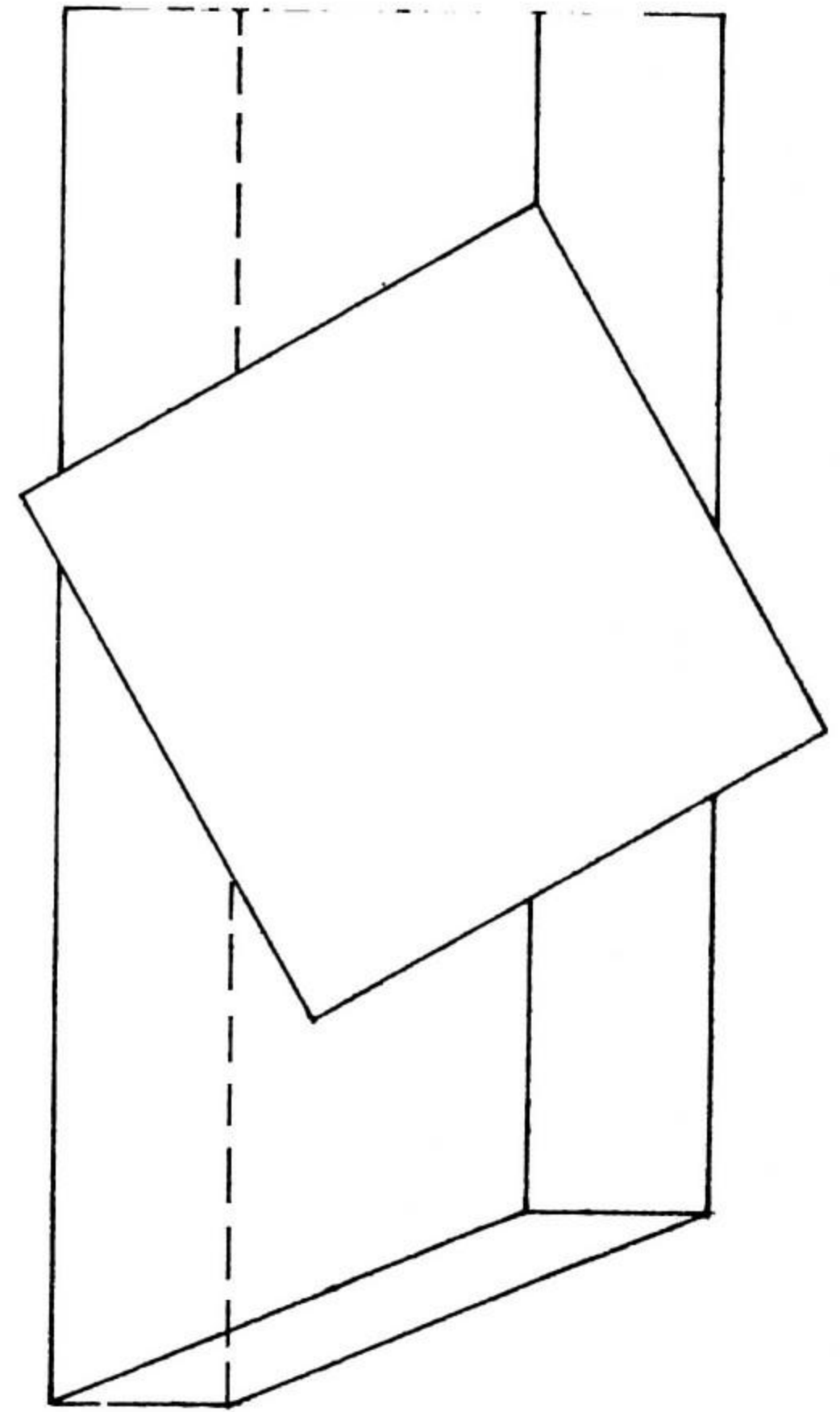
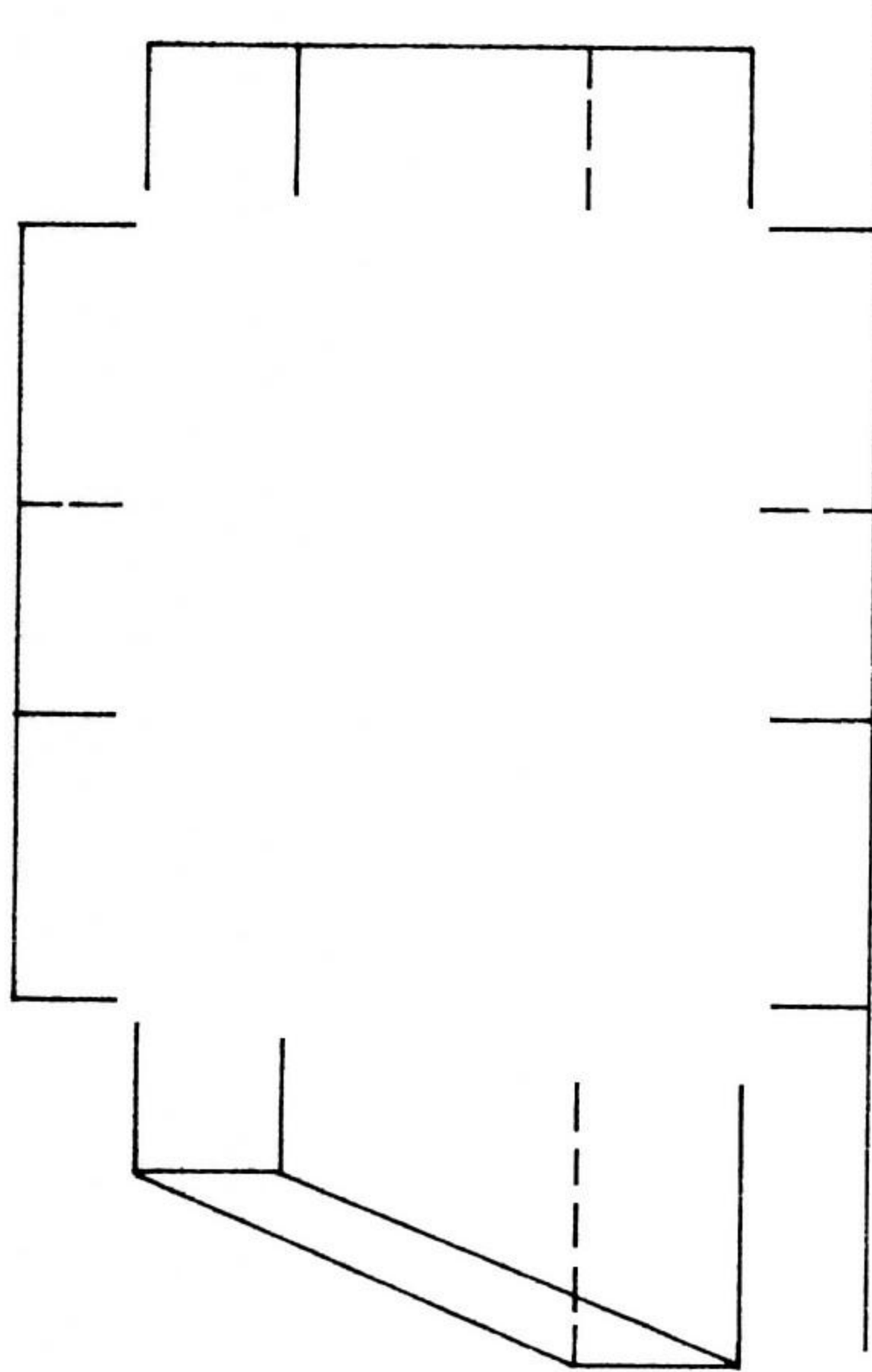

Determinar las intersecciones de los dos prismas.
Considerar homogéneo el poliedro resultante.
Determinar la visibilidad.

D

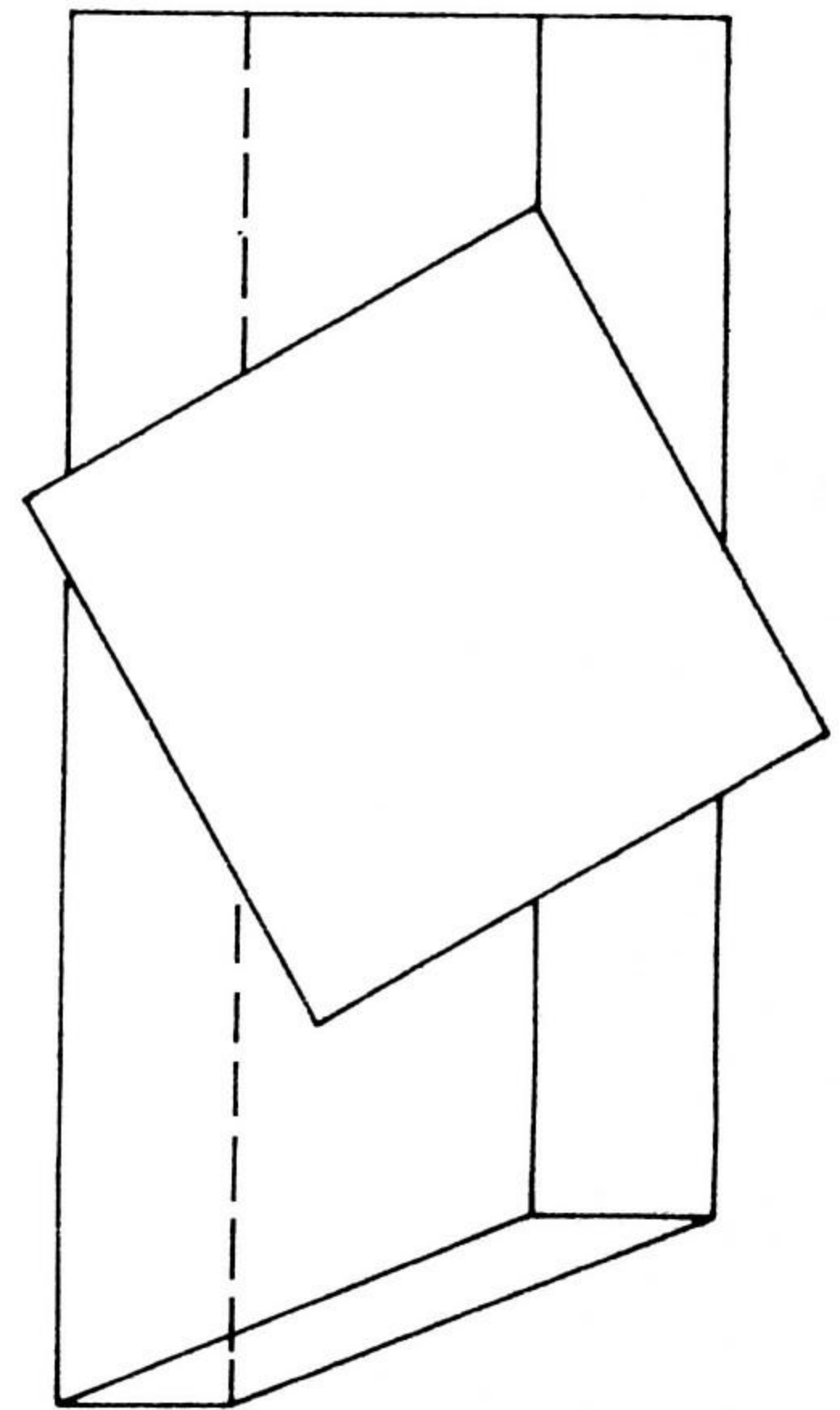
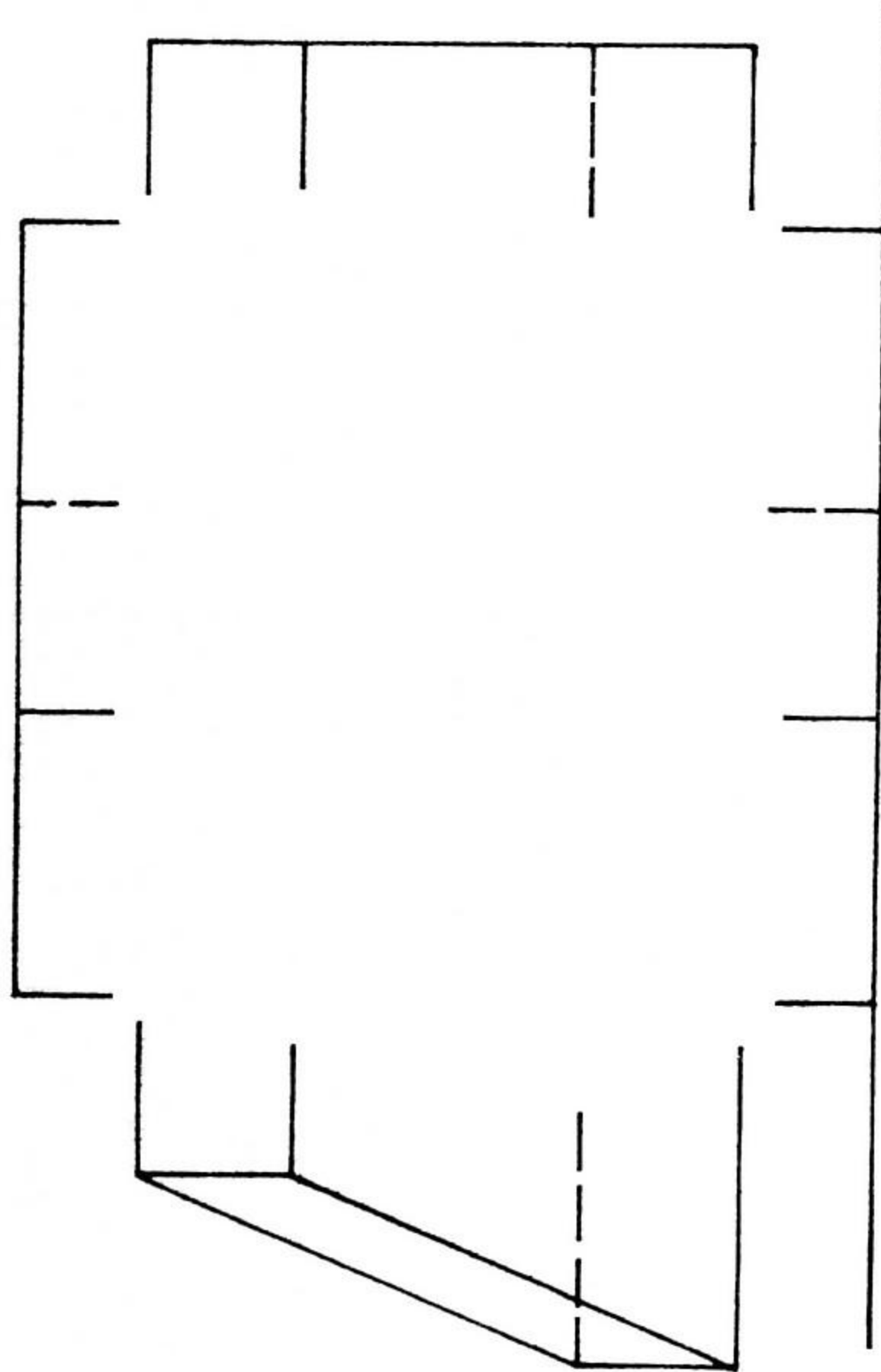

DPTO. DISEÑO BASICO

**ISPJAE
FACULTAD DE ARQUITECTURA**

ASIGNATURA	TEMA			D D D
DOC.	ALUM.	No.	OPC.	
FECHA		EVAL.		

5.5.2 INTERSECCIONES DE POLIEDROS

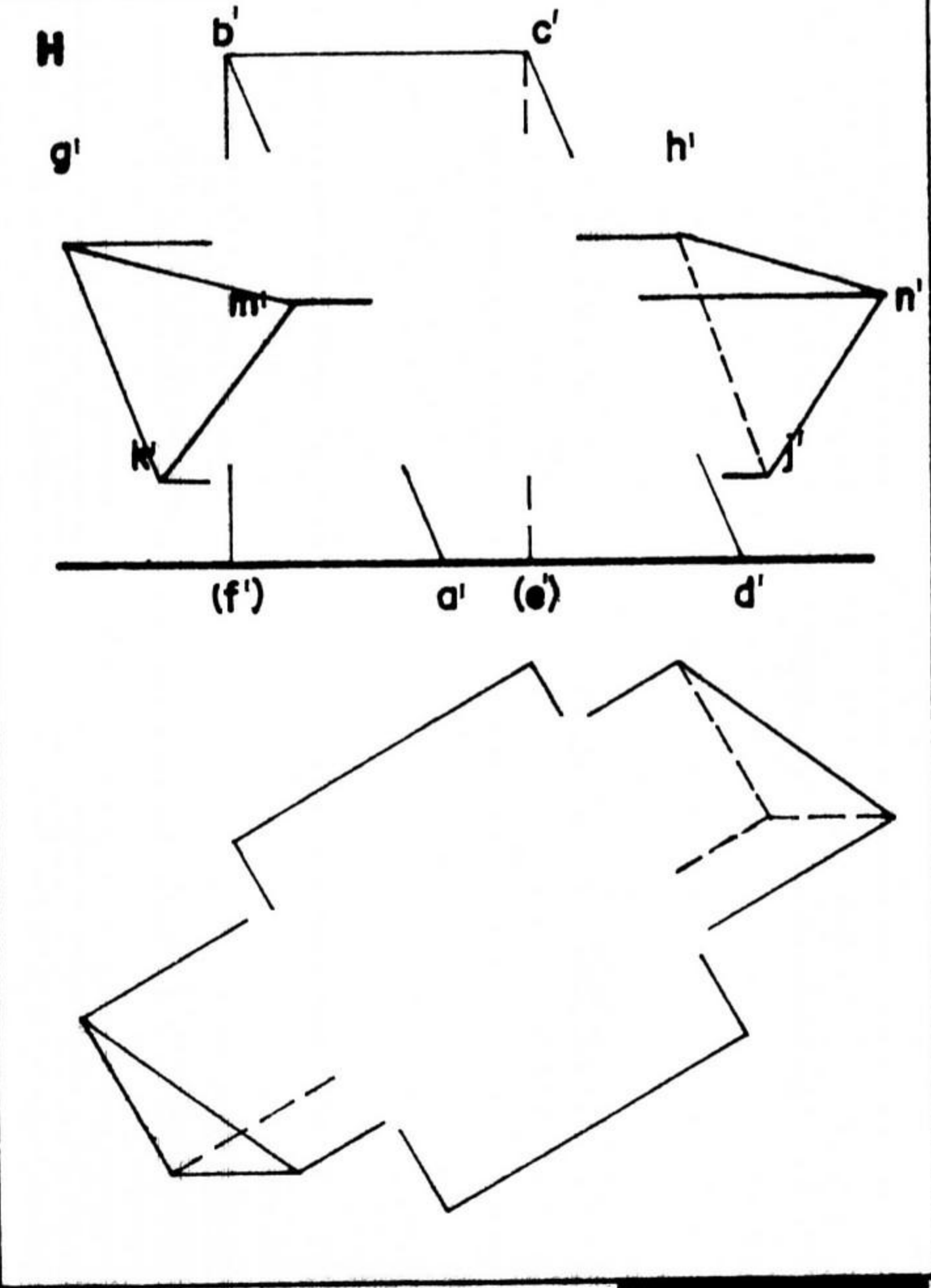
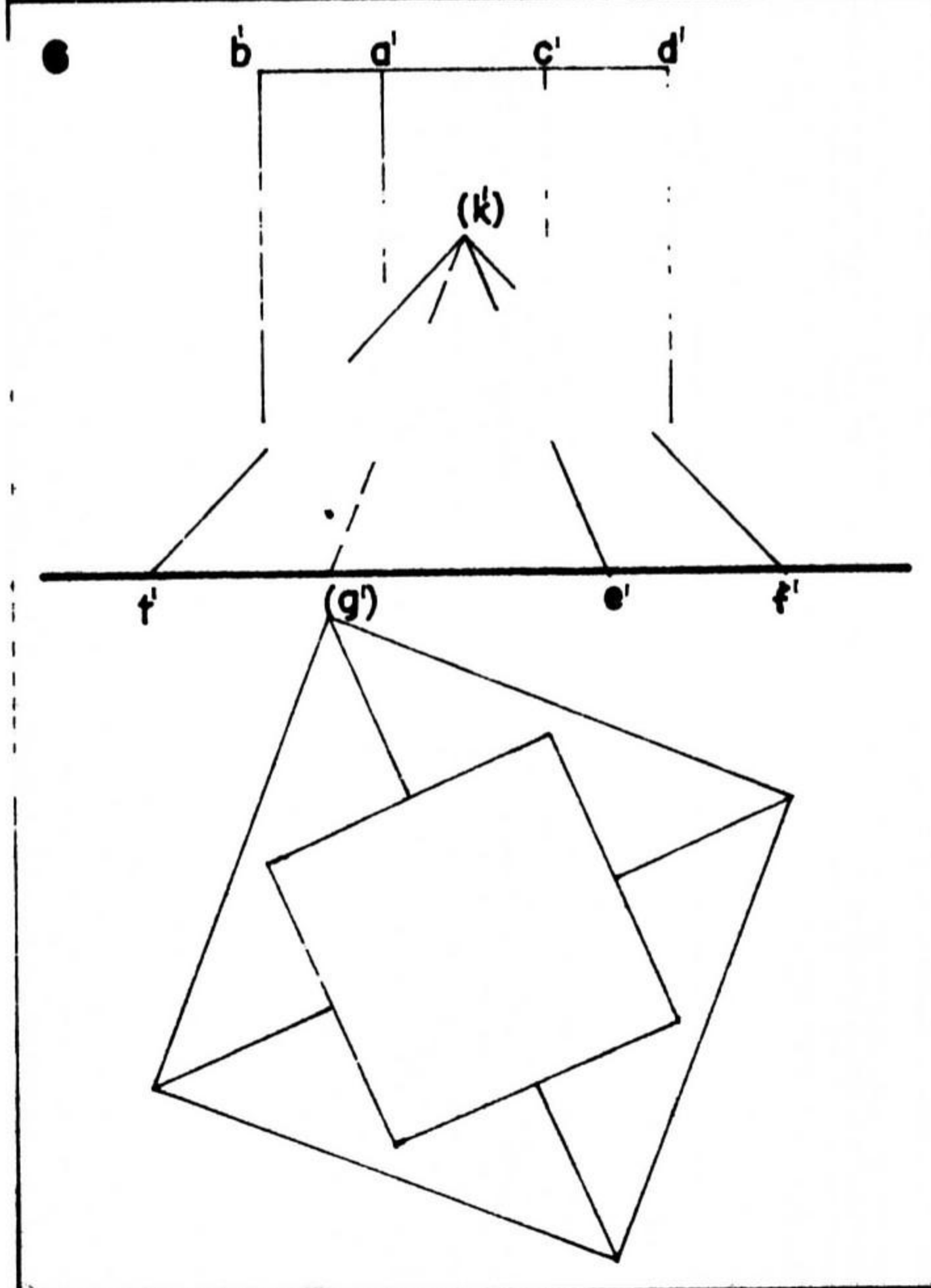
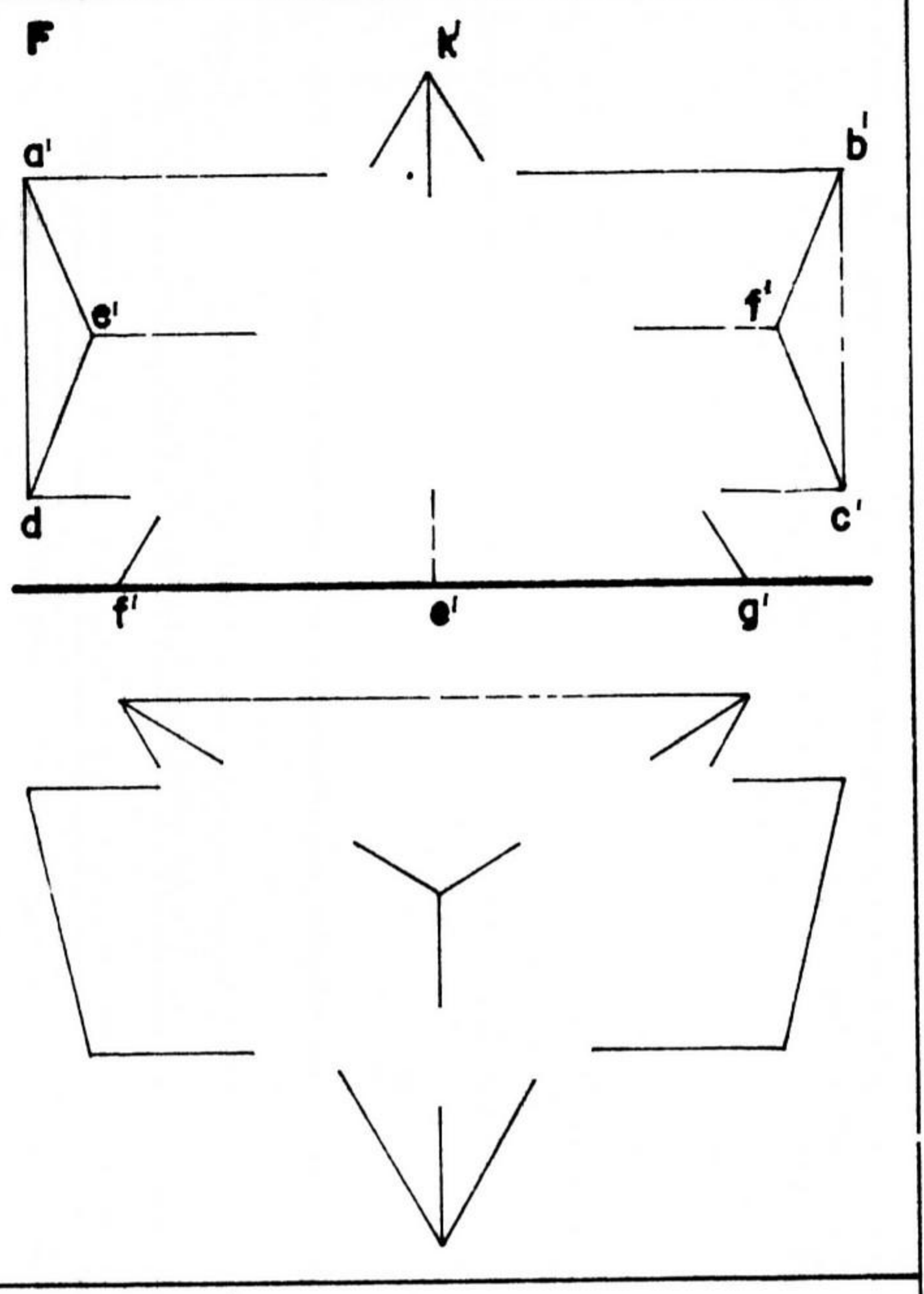
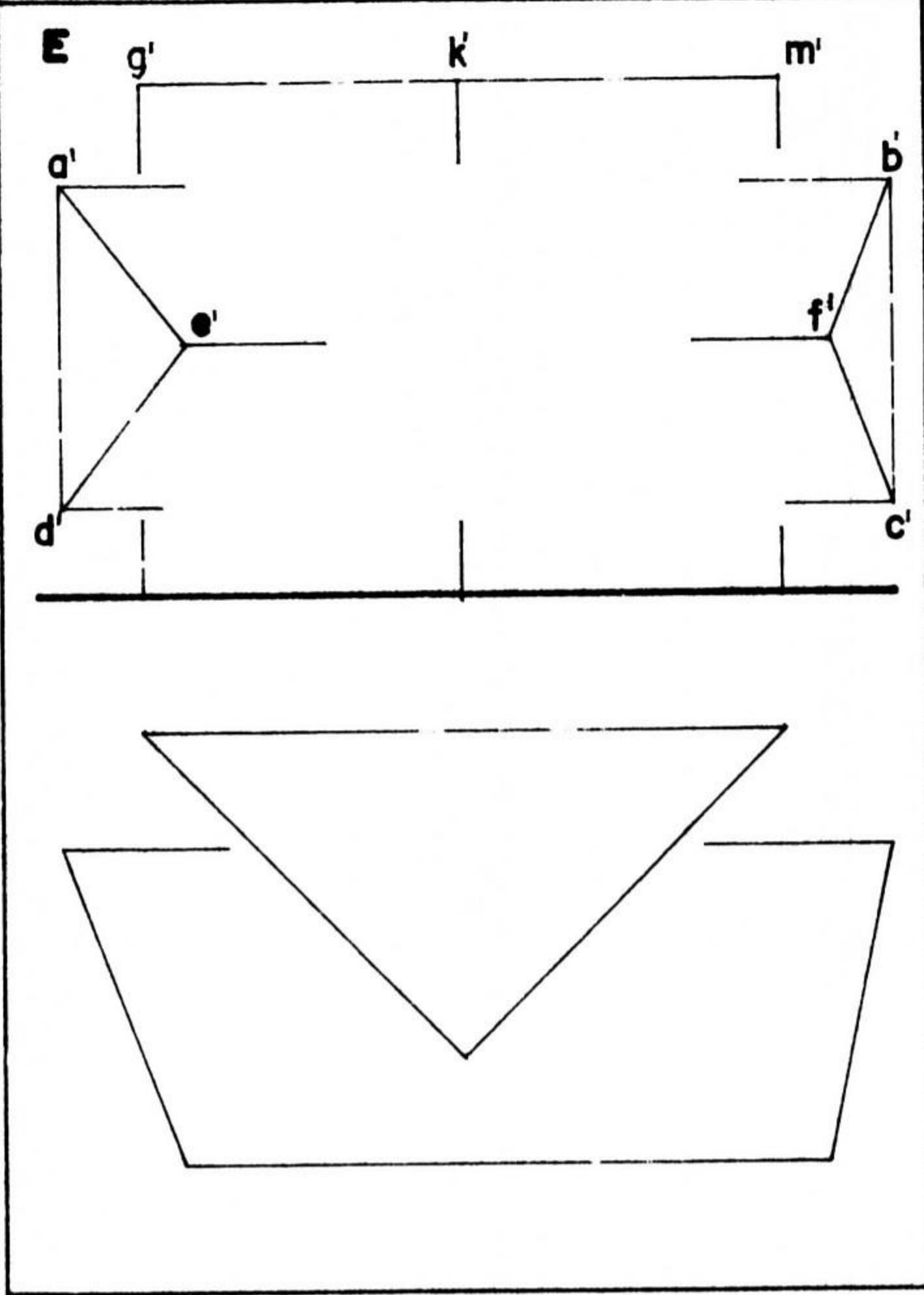

DPTO. DISEÑO BASICO		ISPJAE FACULTAD DE ARQUITECTURA	
ASIGNATURA	TEMA	No.	GRUPO
DOC.	ALUM.	EVAL	
FECHA			

5.5.2 INTERSECCIONES DE POLIEDROS. PRISMAS

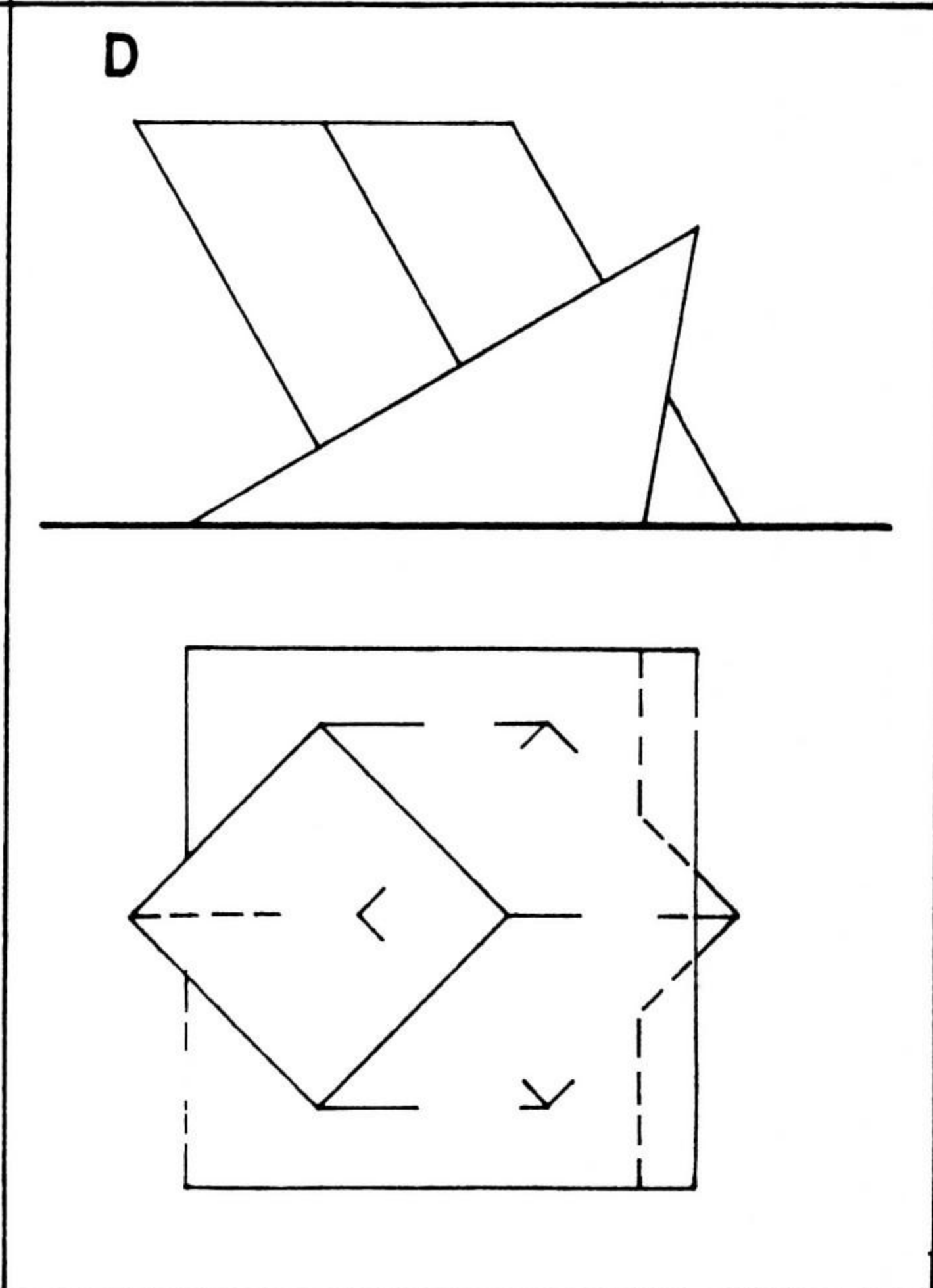
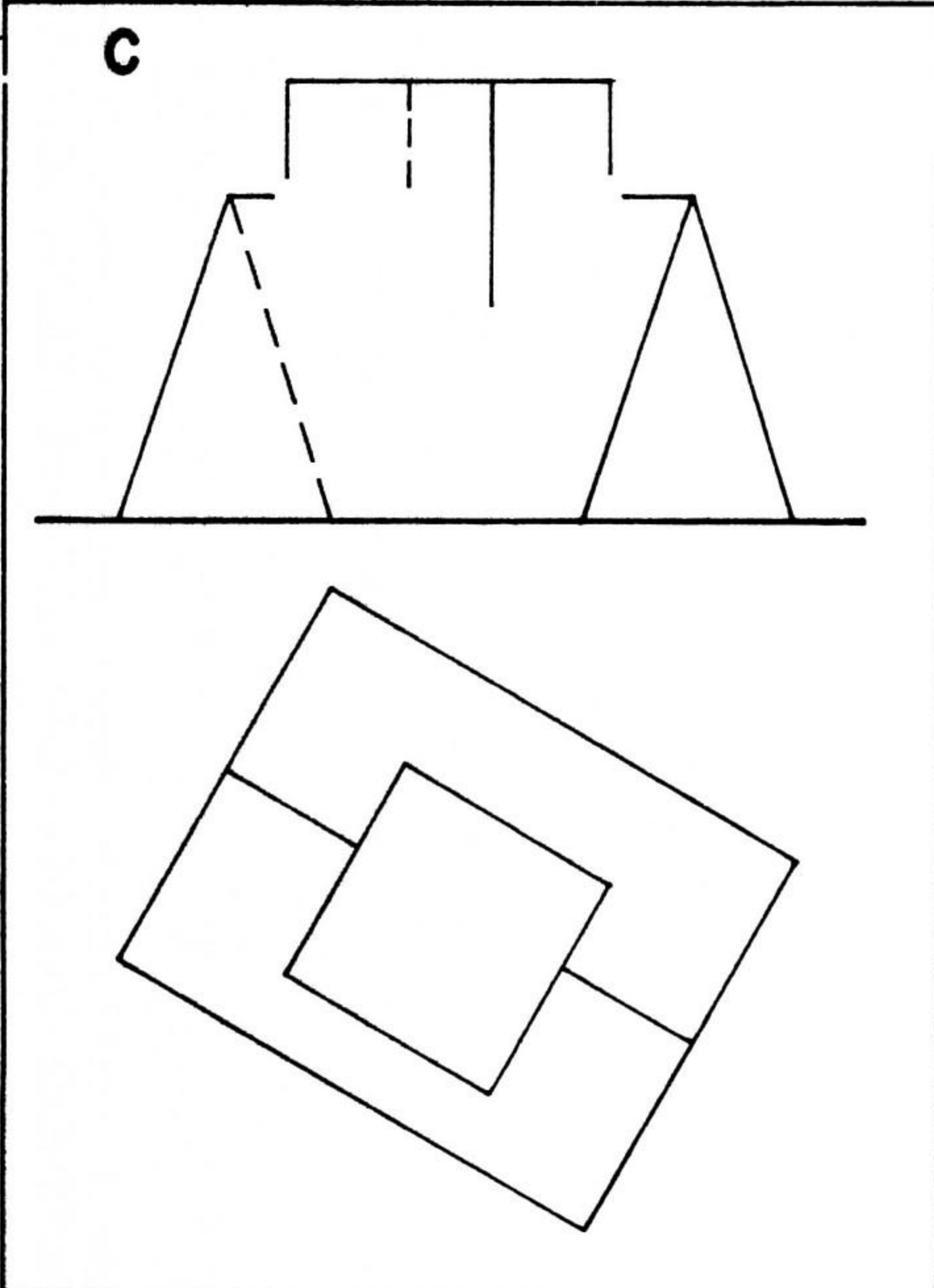
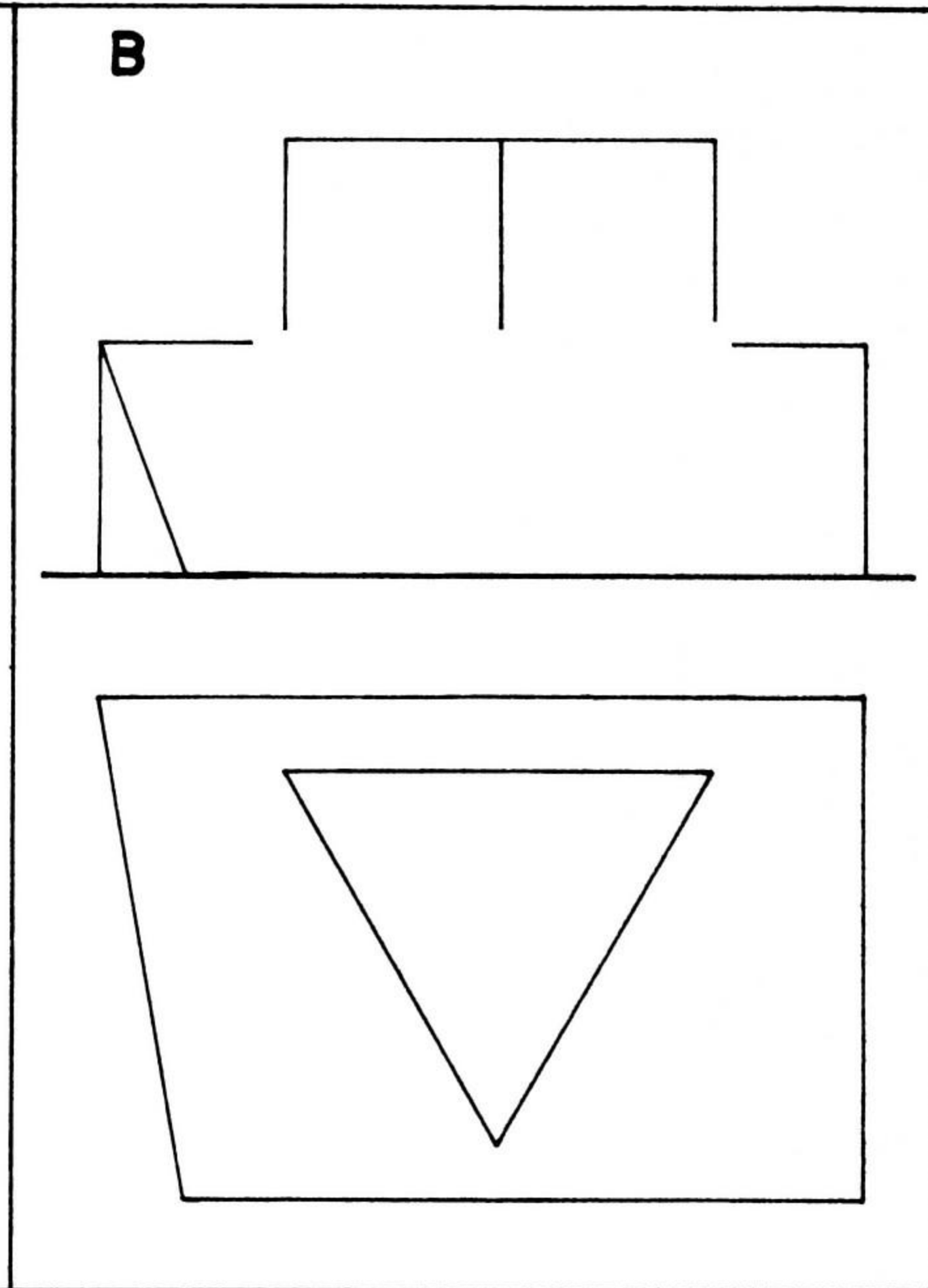
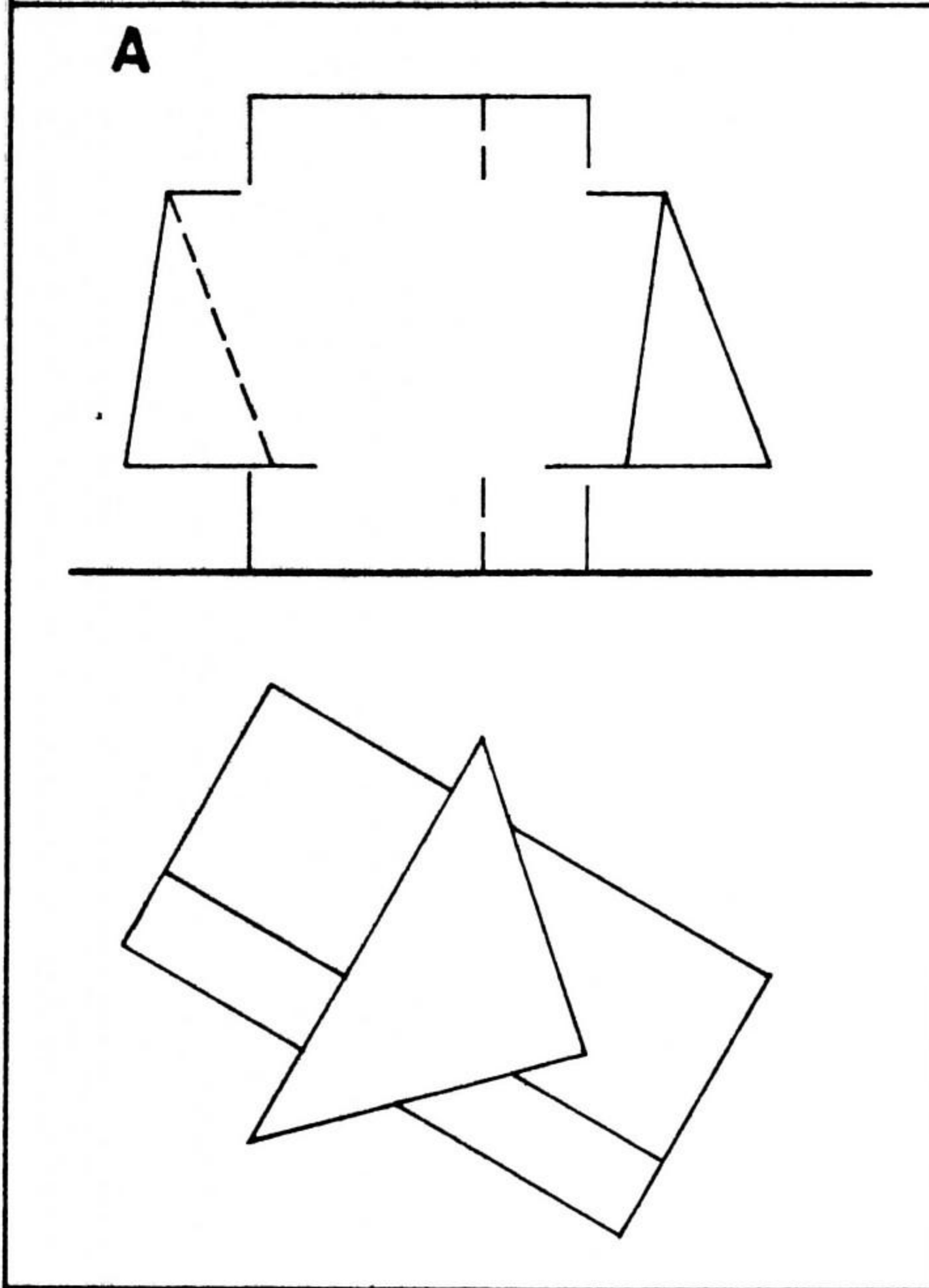

DPTO. DISEÑO BASICO		ISPJAE FACULTAD DE ARQUITECTURA	
ASIGNATURA	TEMA		
DOC.	ALUM.	No.	GRUPO.
FECHA		EVAL.	



5.5.2 INTERSECCIONES DE POLIEDROS - VISIBILIDAD

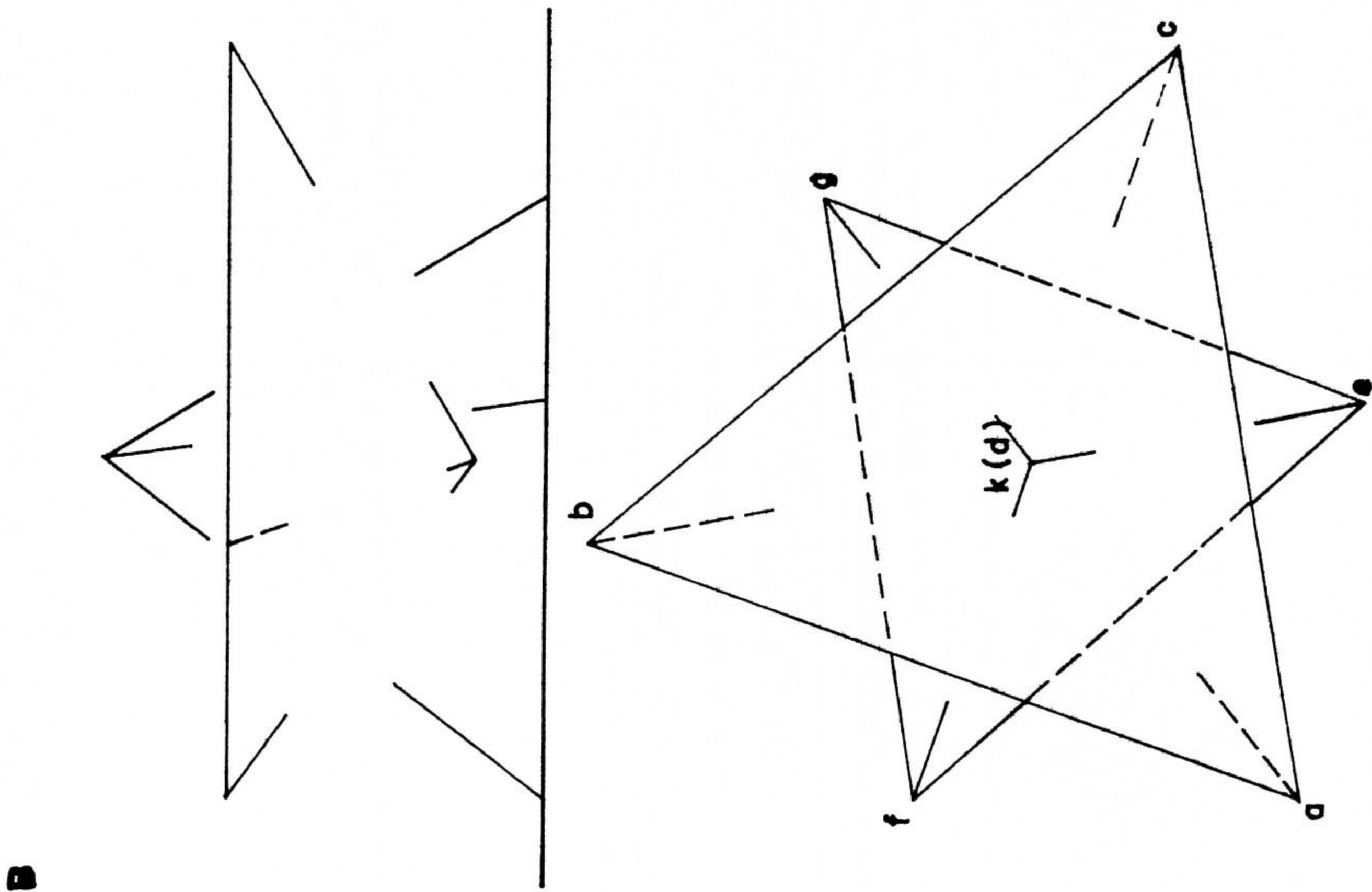

B

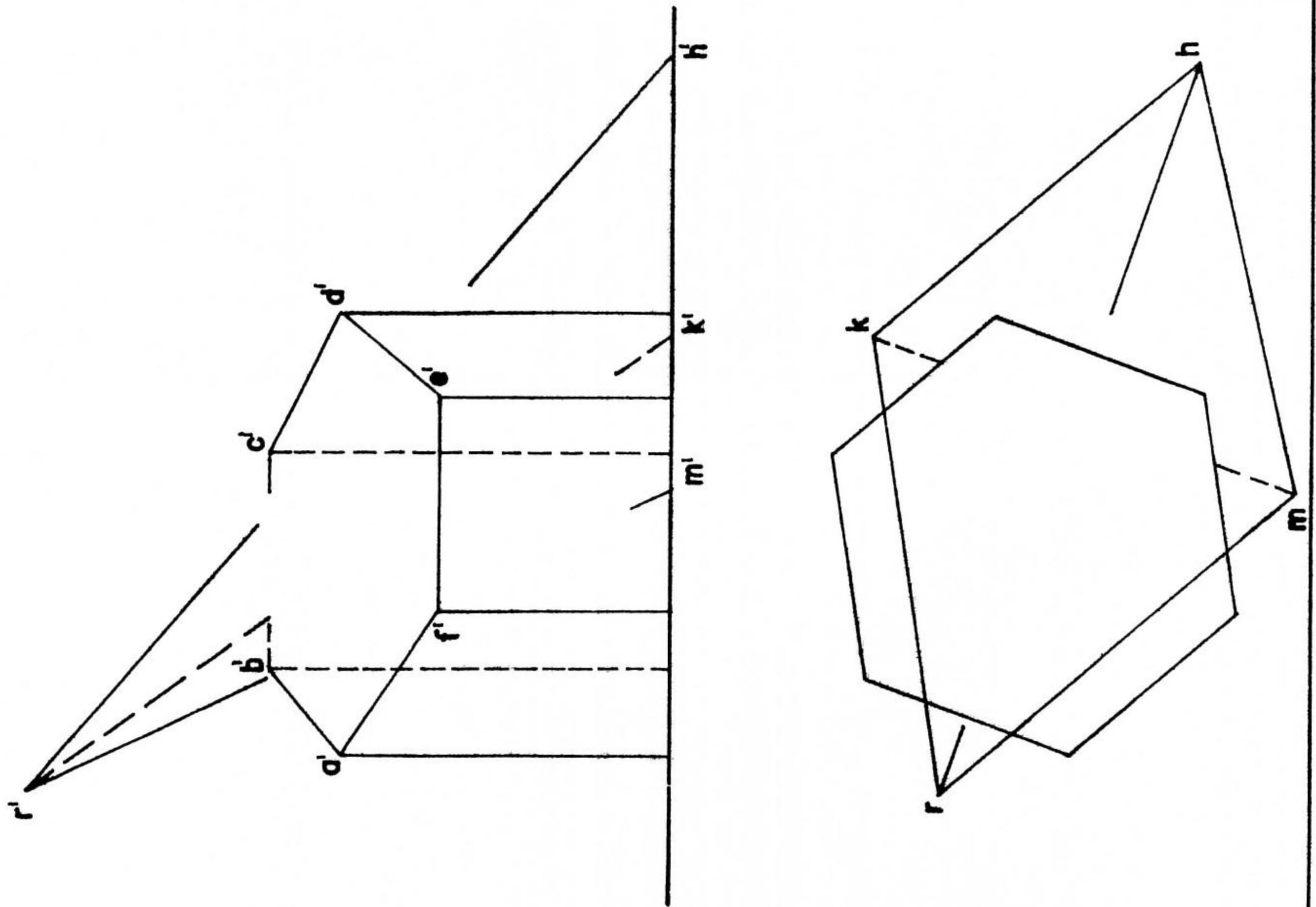

A

DPTO. DISEÑO BASICO

ISPJAE FACULTAD DE ARQUITECTURA

ARQUITECTURA

TEMA

DOC.

ALUM.

No.

OPG.

FECHA

EVAL.

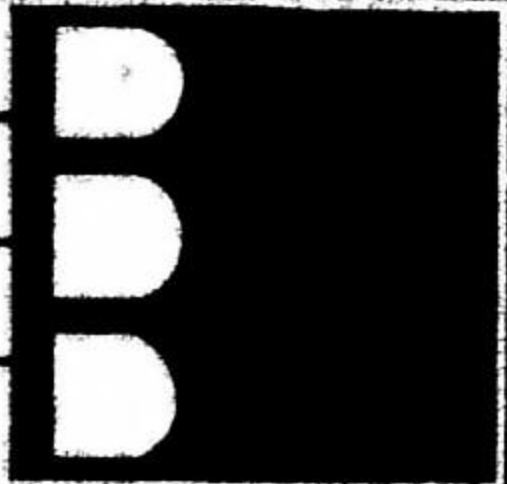

5.5.2 INTERSECCIONES. DESARROLLO.

CONSTRUIR LA PROYECCION HORIZONTAL DE LA SECCION RECTA DEL PRISMA DETERMINAR SU FORMA REAL POR ABATIMIENTO.

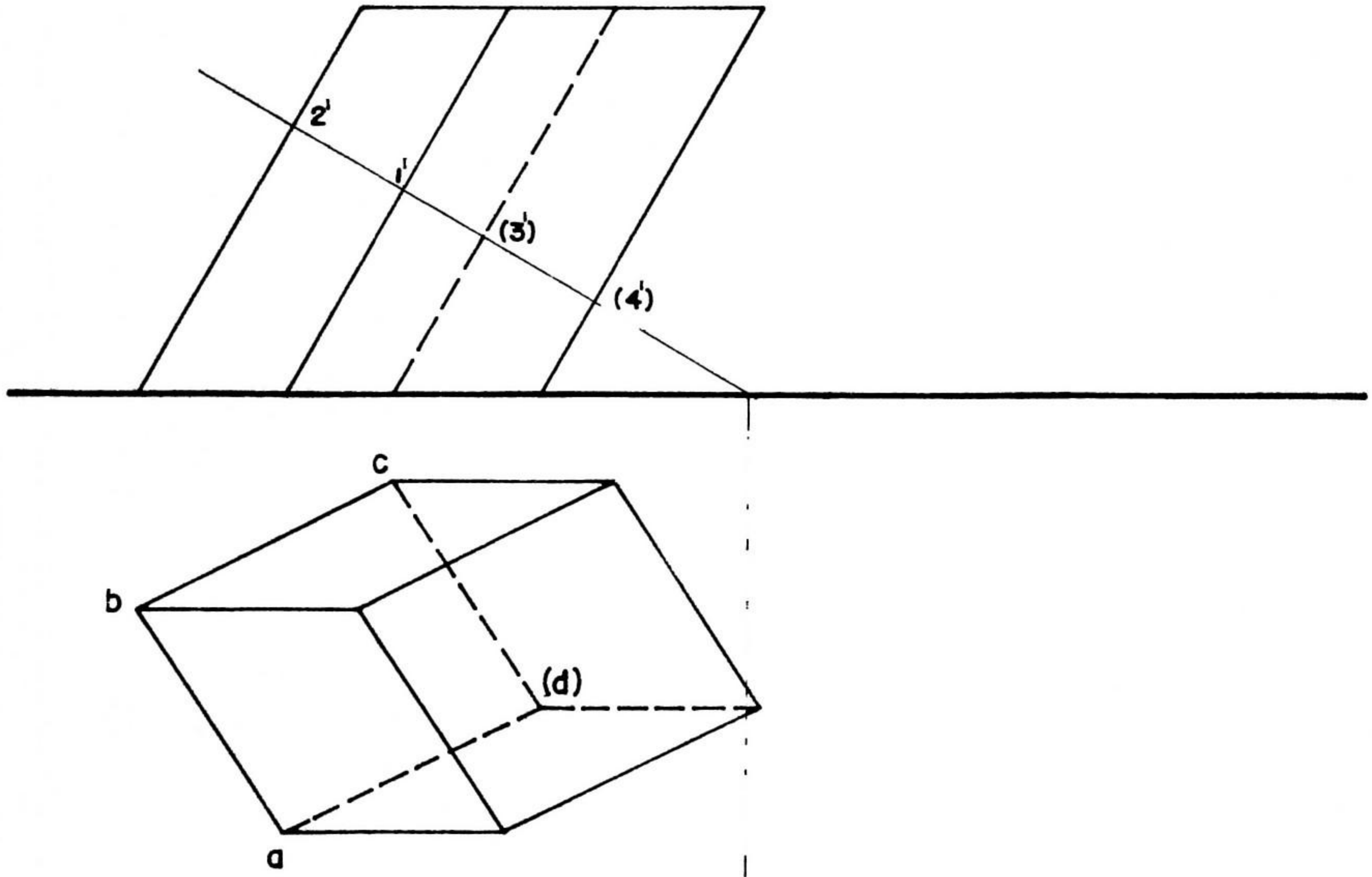

CONSTRUIR EL DESARROLLO DE LA MITAD DEL PRISMA (DESPUES DE SECCIONADA) INDICAR LA CONSTRUCCION.

DPTO. DISEÑO BASICO		ISPJAE FACULTAD DE ARQUITECTURA		D D D
ASIGNATURA	TEMA			
DOC.	ALUM.	No.	GPO.	
FECHA			EVAL.	

5.5.3 CONSTRUIR EL DESARROLLO EN CADA CASO

1

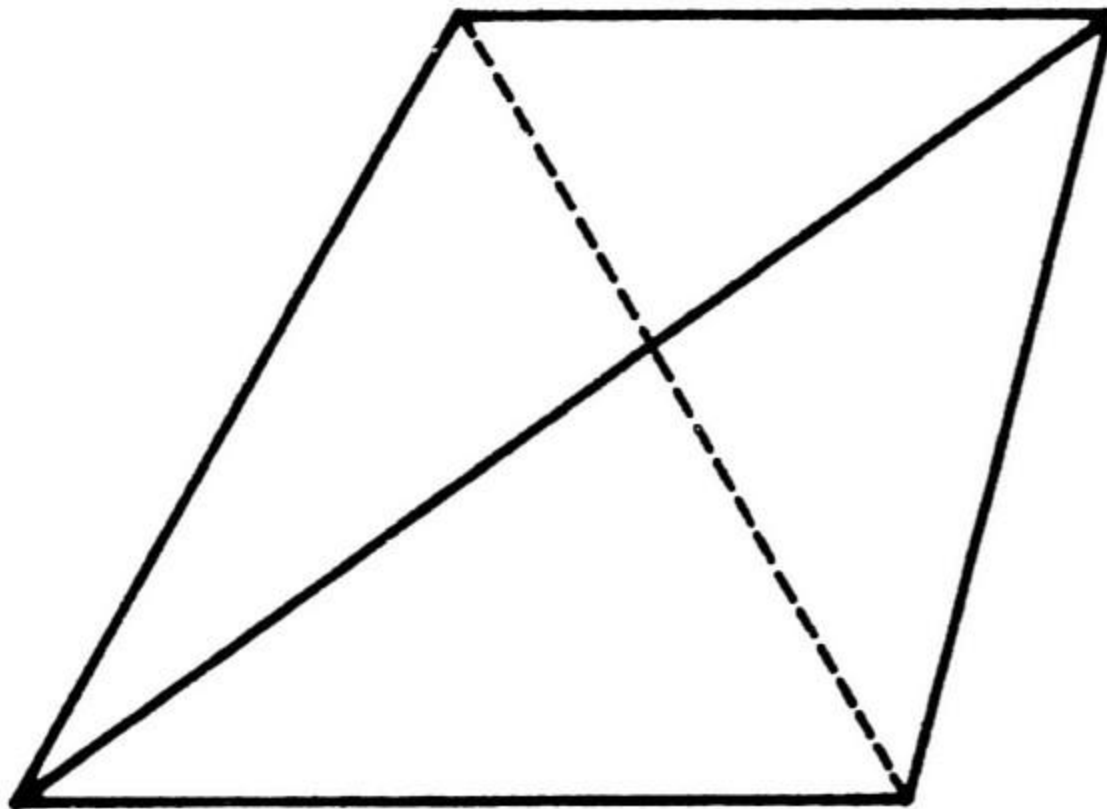
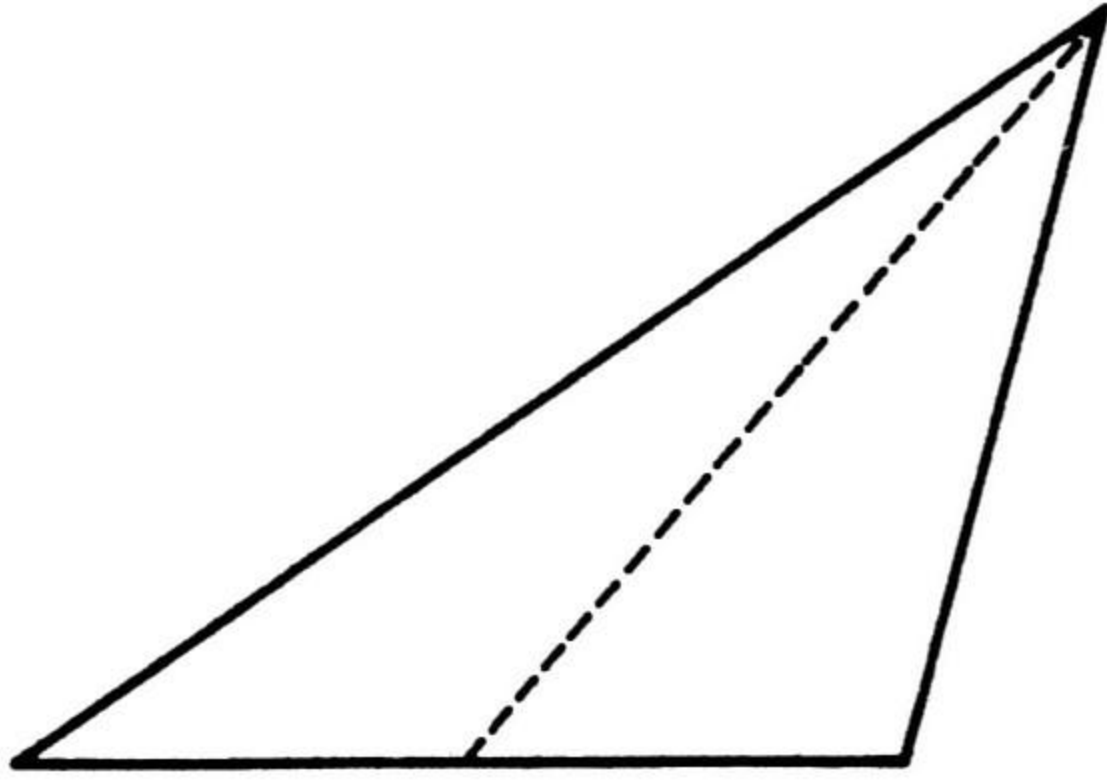

2

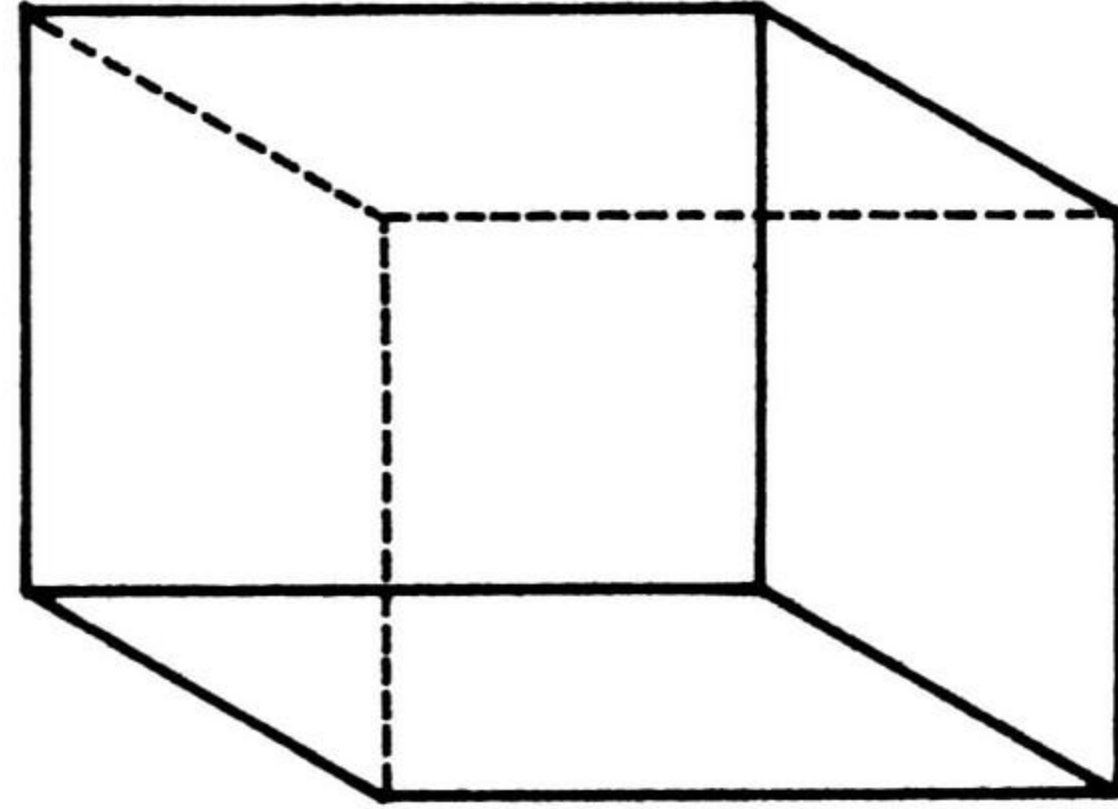
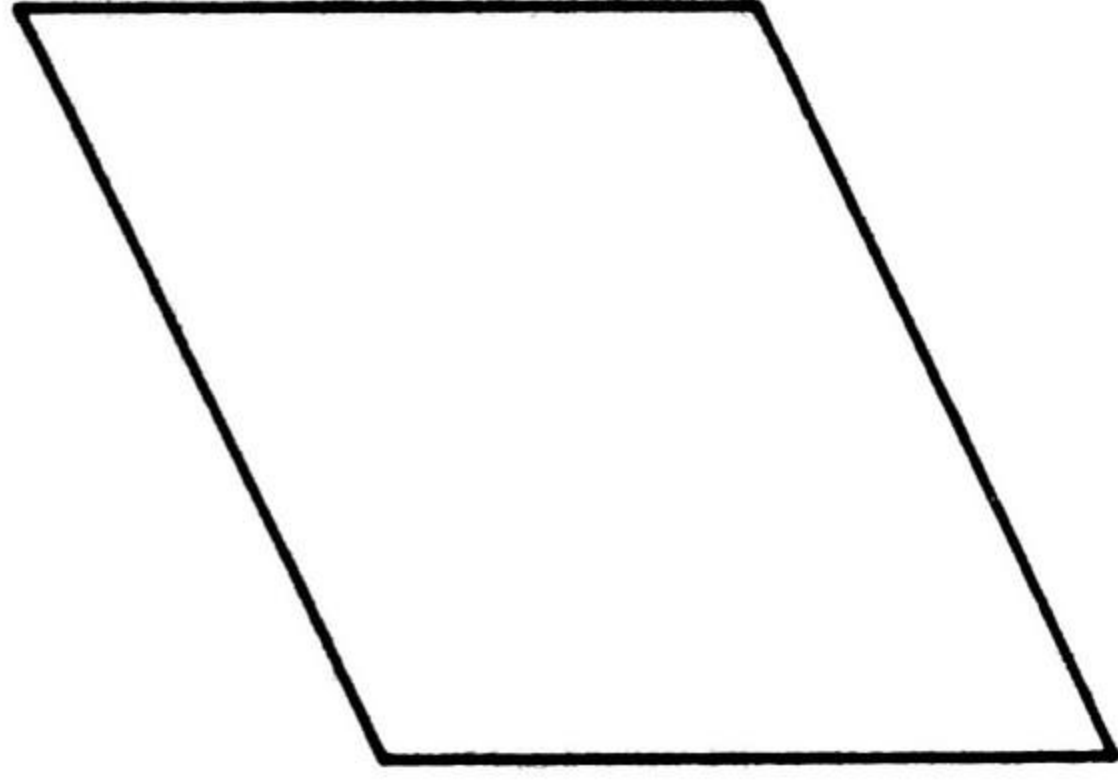

3

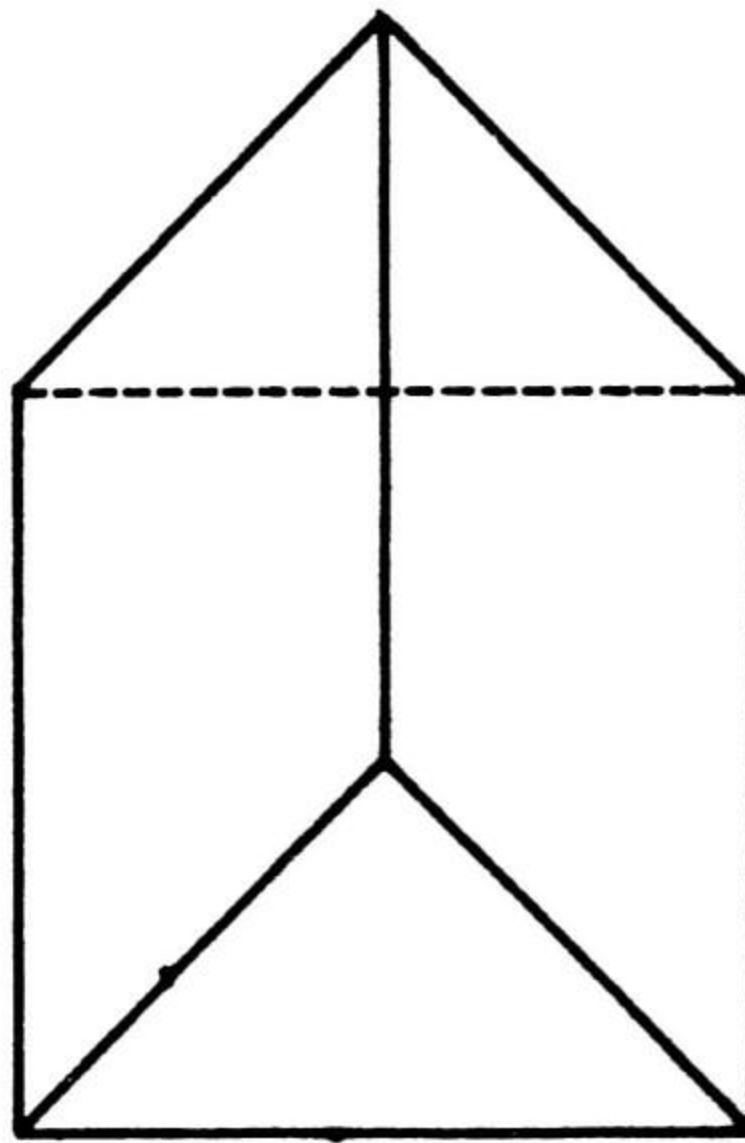
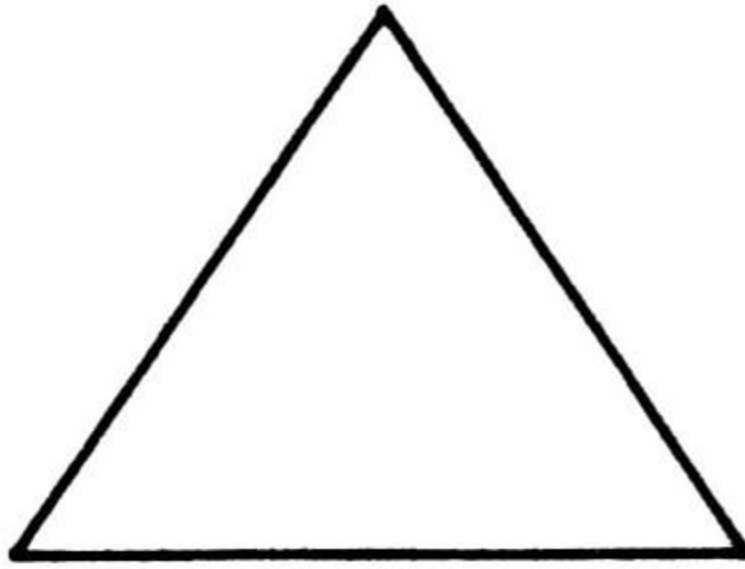

4

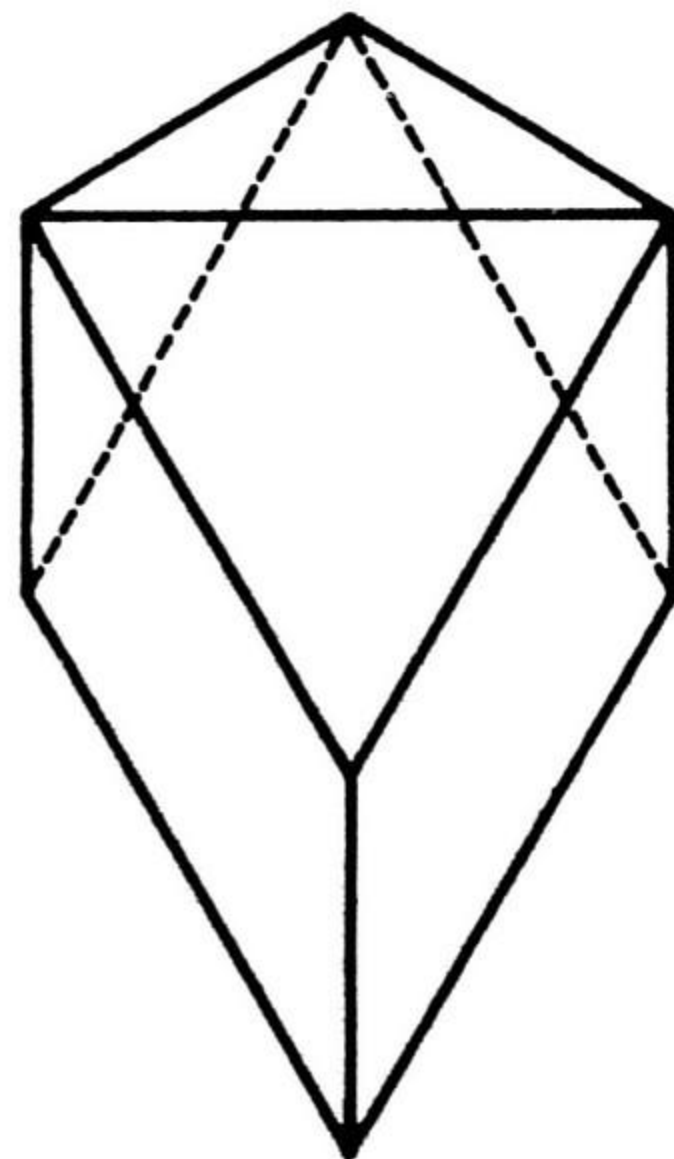
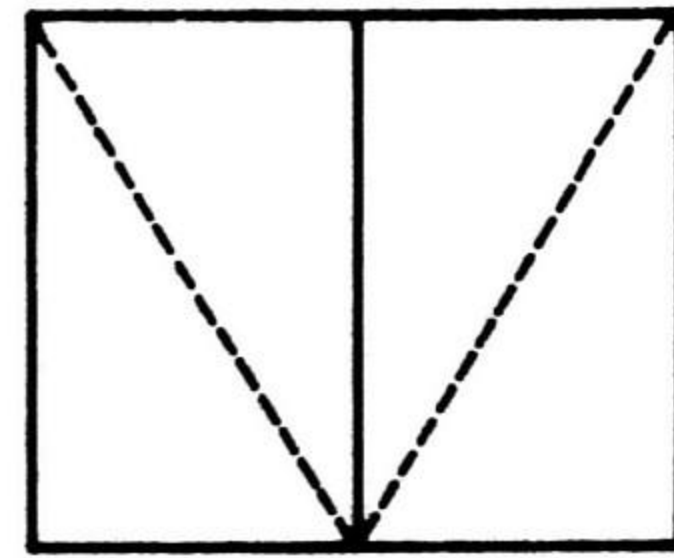

DPTO. DISEÑO BASICO

ISPJAE FACULTAD DE ARQUITECTURA

ASIGNATURA

TEMA

DOC.

ALUM.

No.

GPO.

FECHA

EVAL.

6.2.2 CÍRCULOS - DETERMINAR LA FORMA EN QUE SE PERCIBEN LOS DIÁMETROS

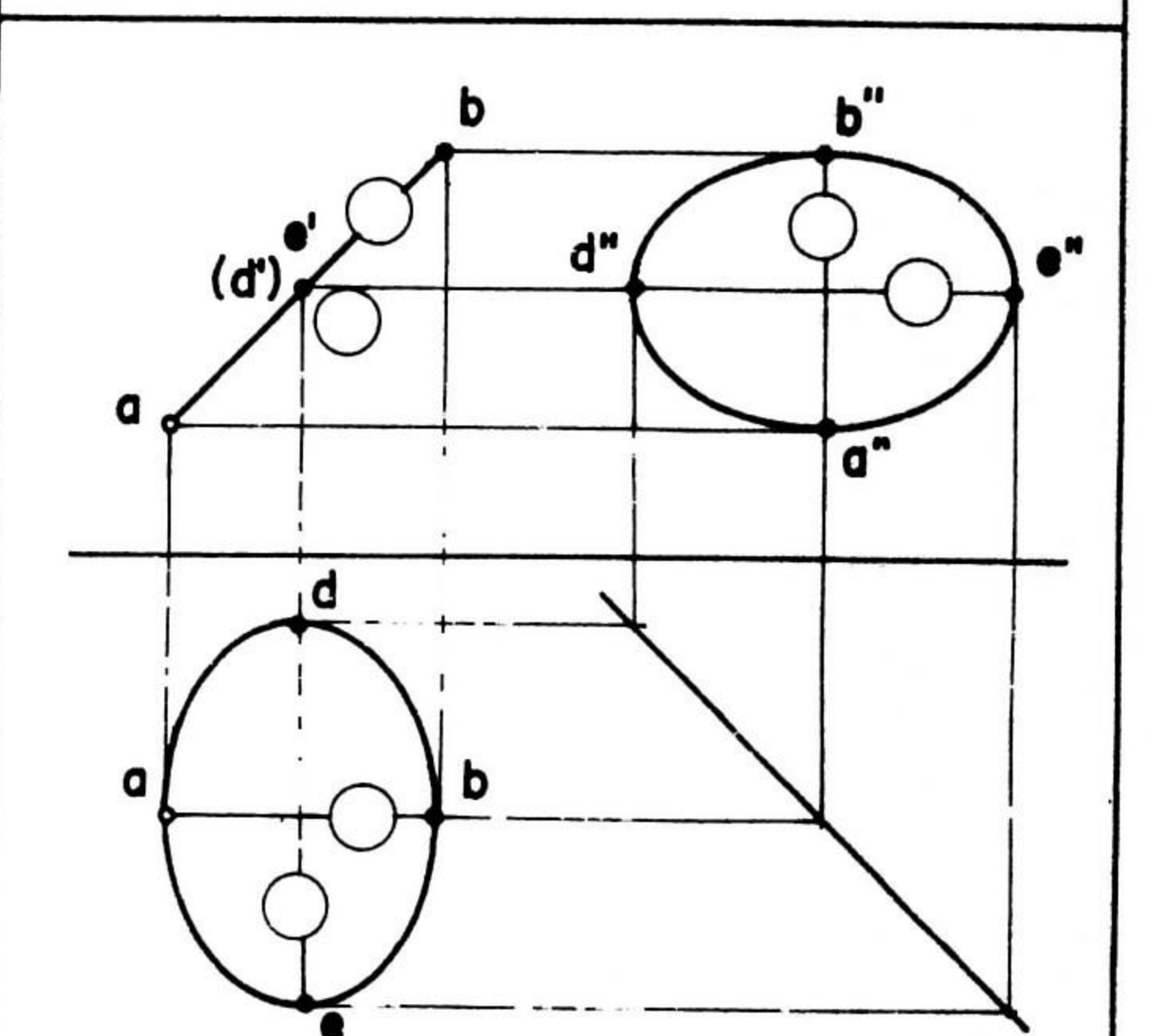
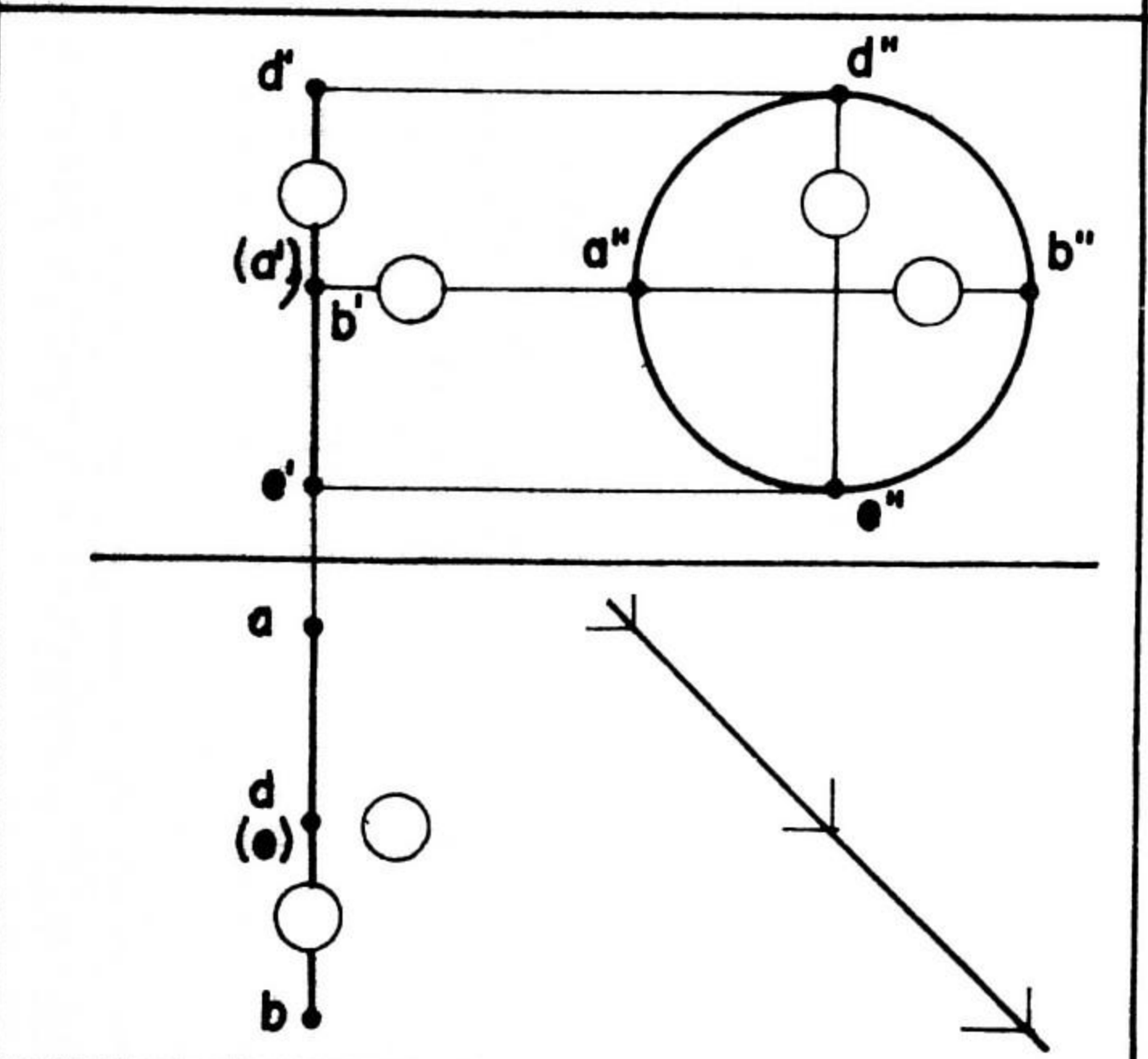
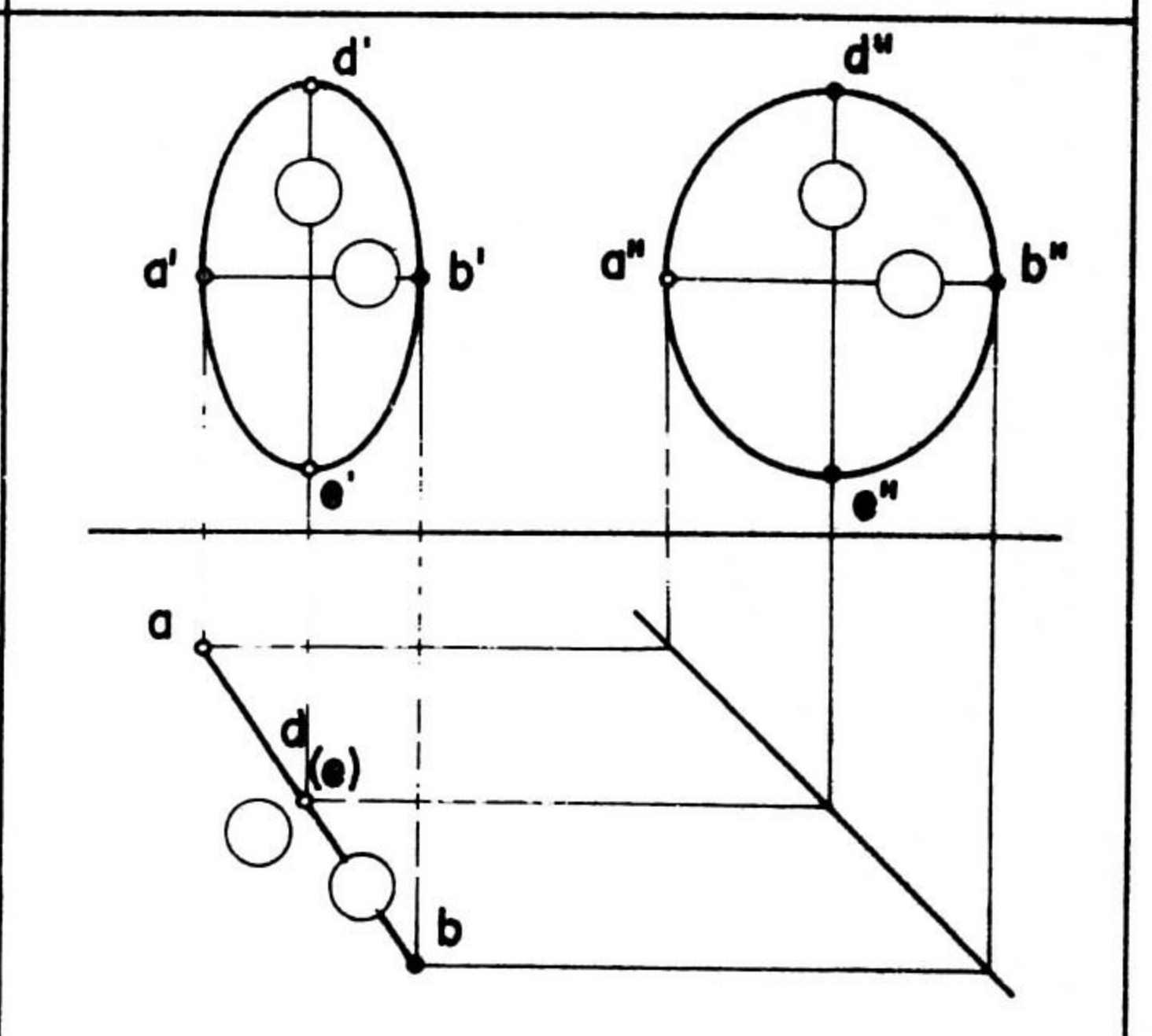
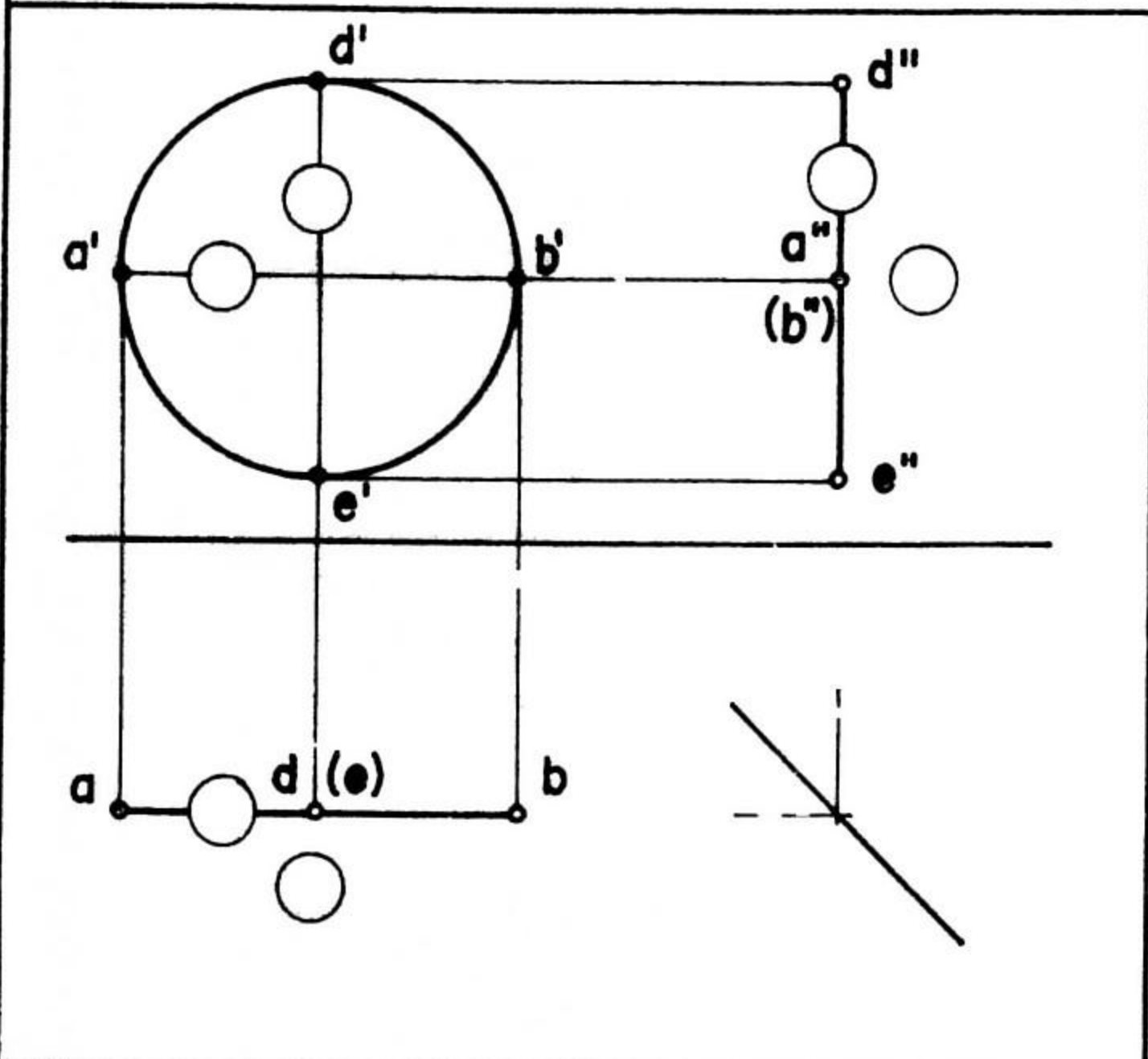
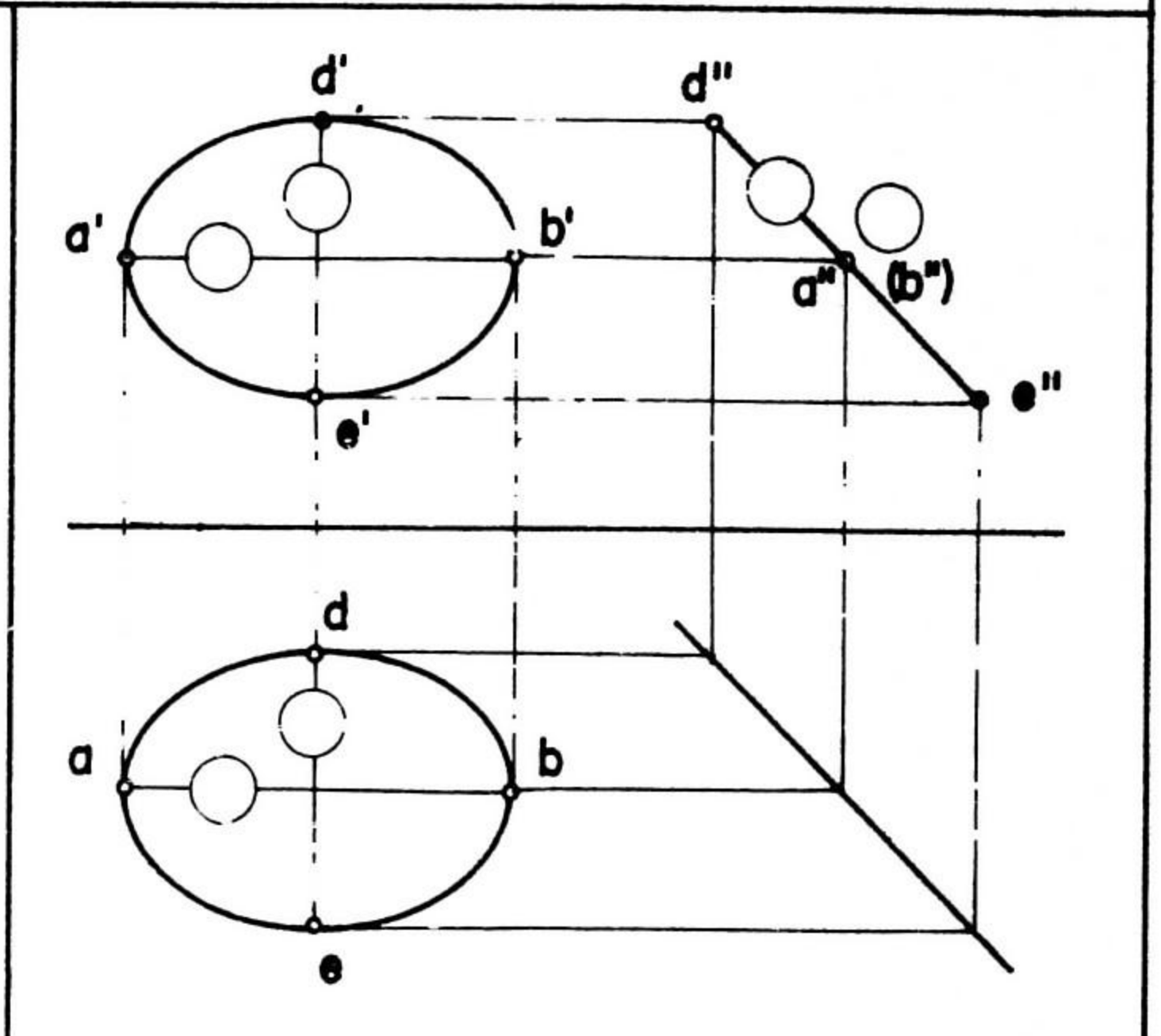
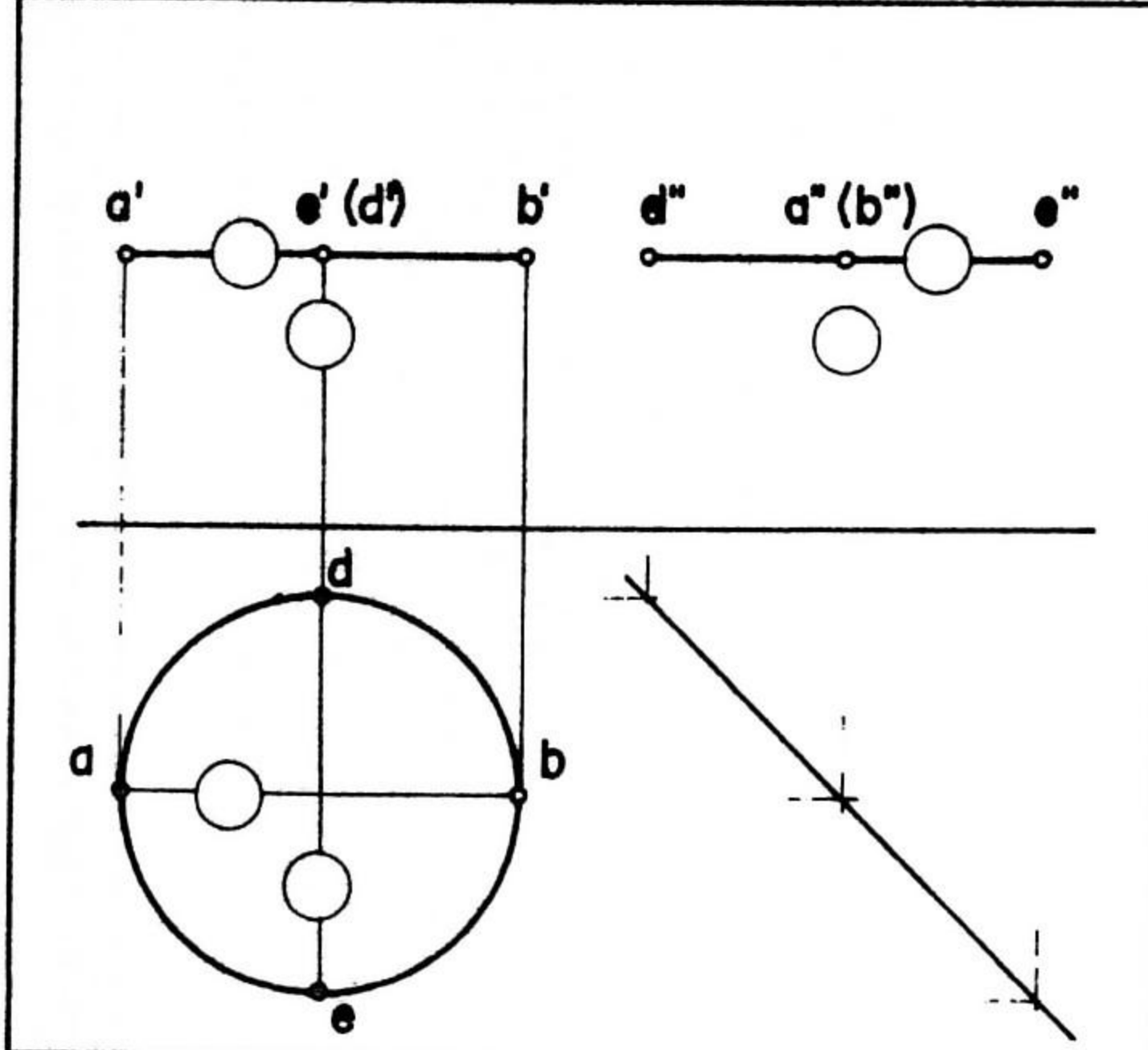

DPTO. DISEÑO BASICO		ISPJAE FACULTAD DE ARQUITECTURA	
ASIGNATURA	TEMA	No.	GRUPO
DOC.	ALUM.	EVAL.	
FECHA			

6.2 DIBUJAR : VISTA LATERAL Y EL ISOMETRICO

A

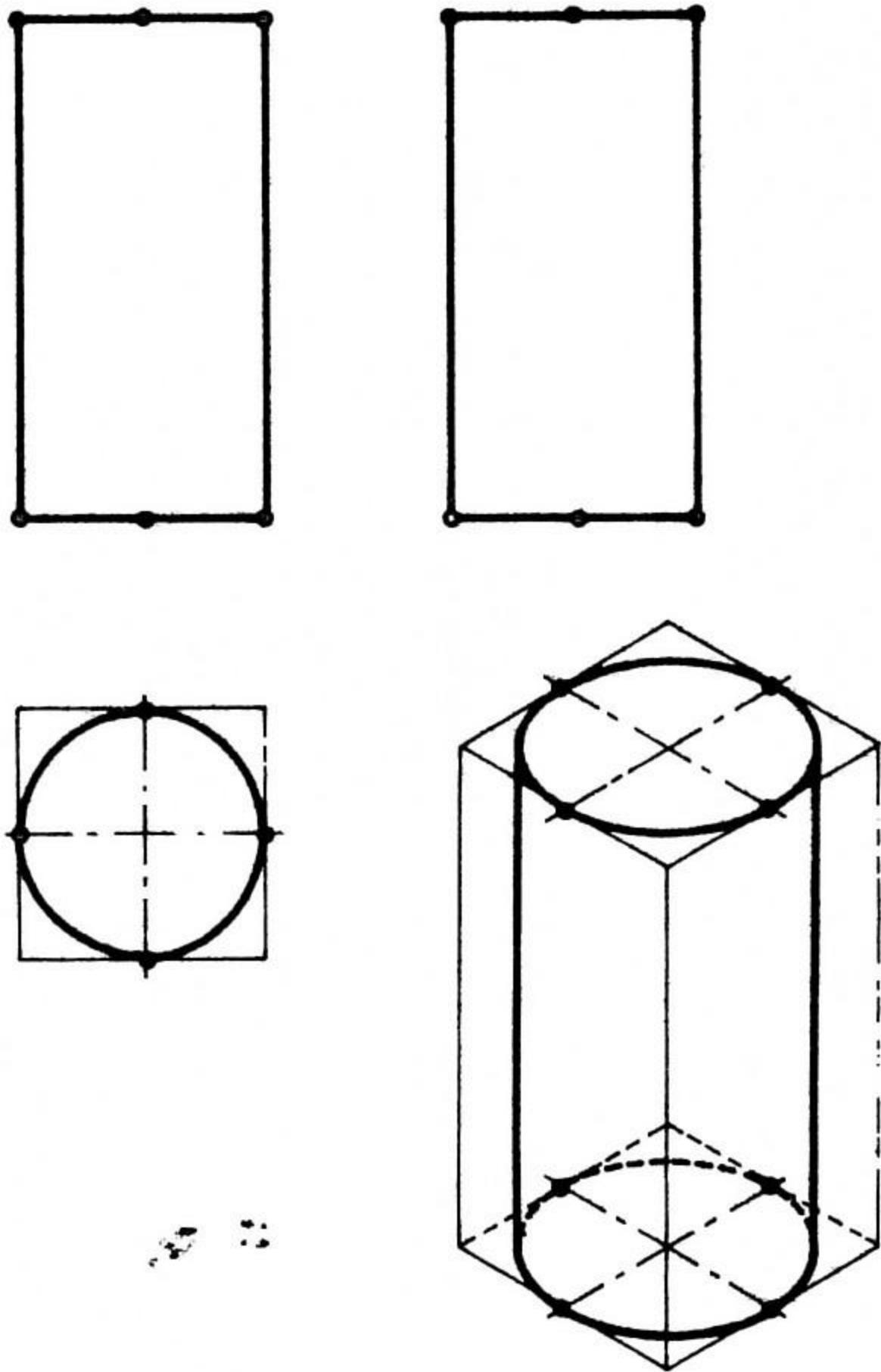

B

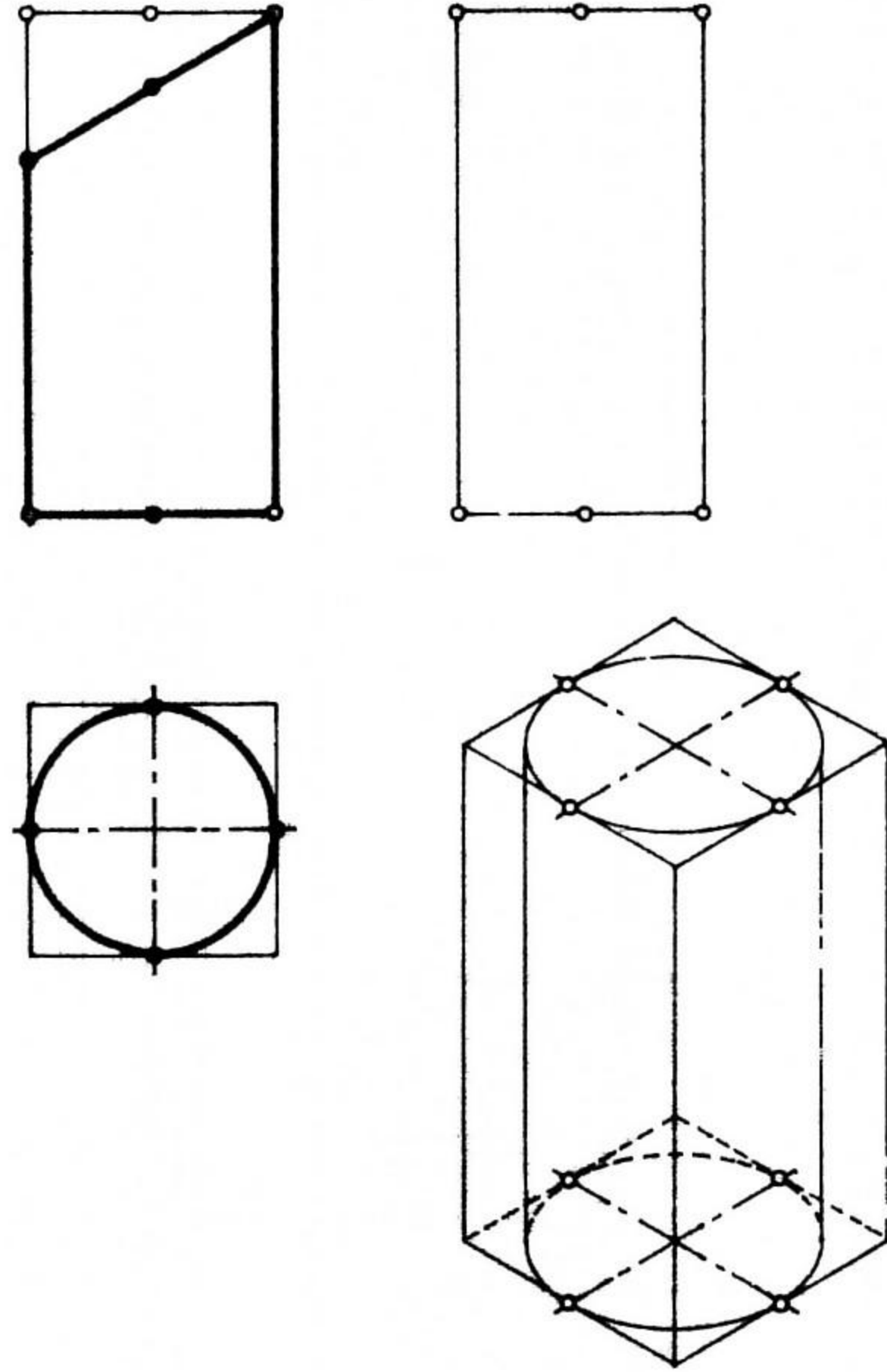

C

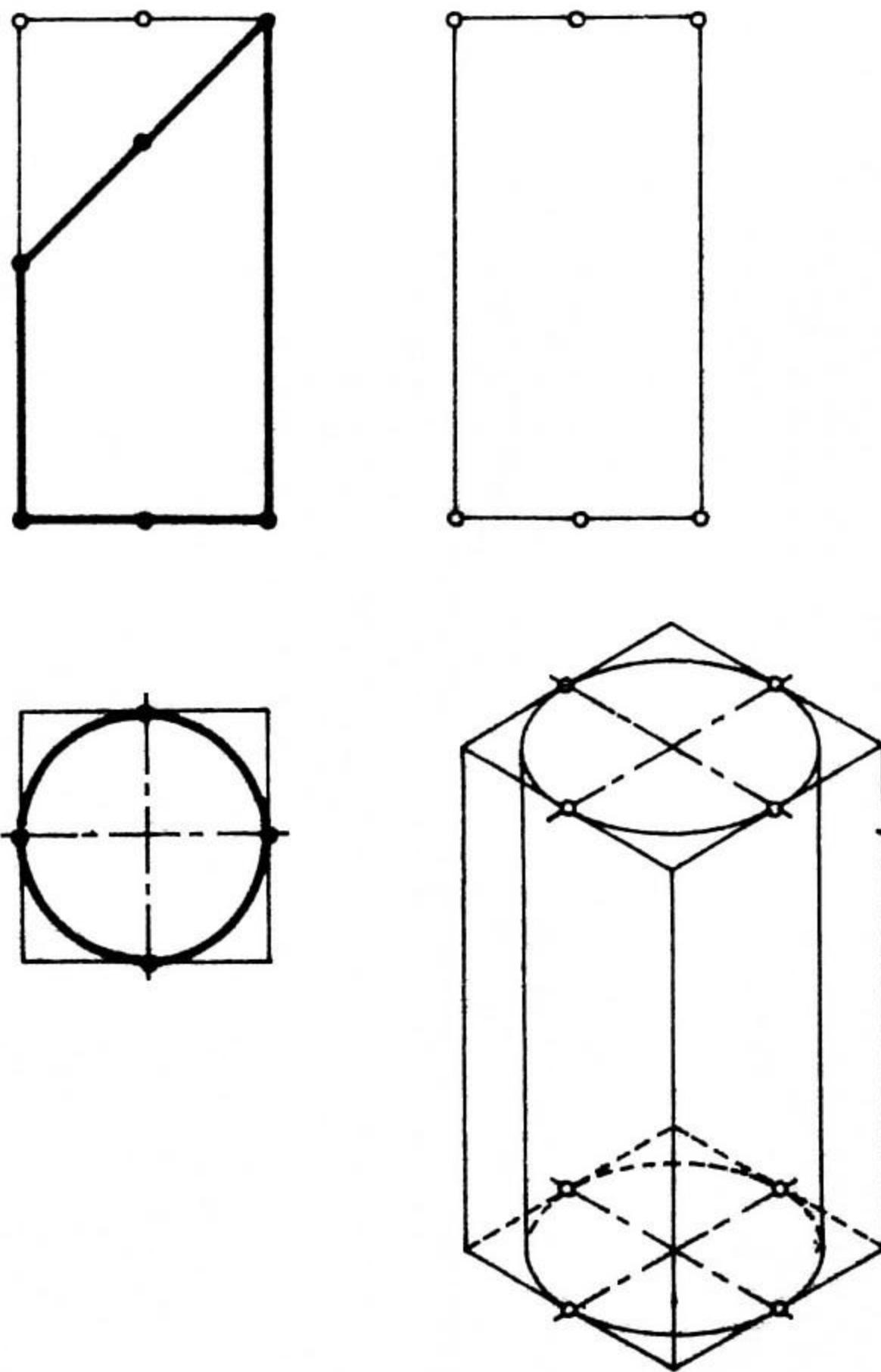

D

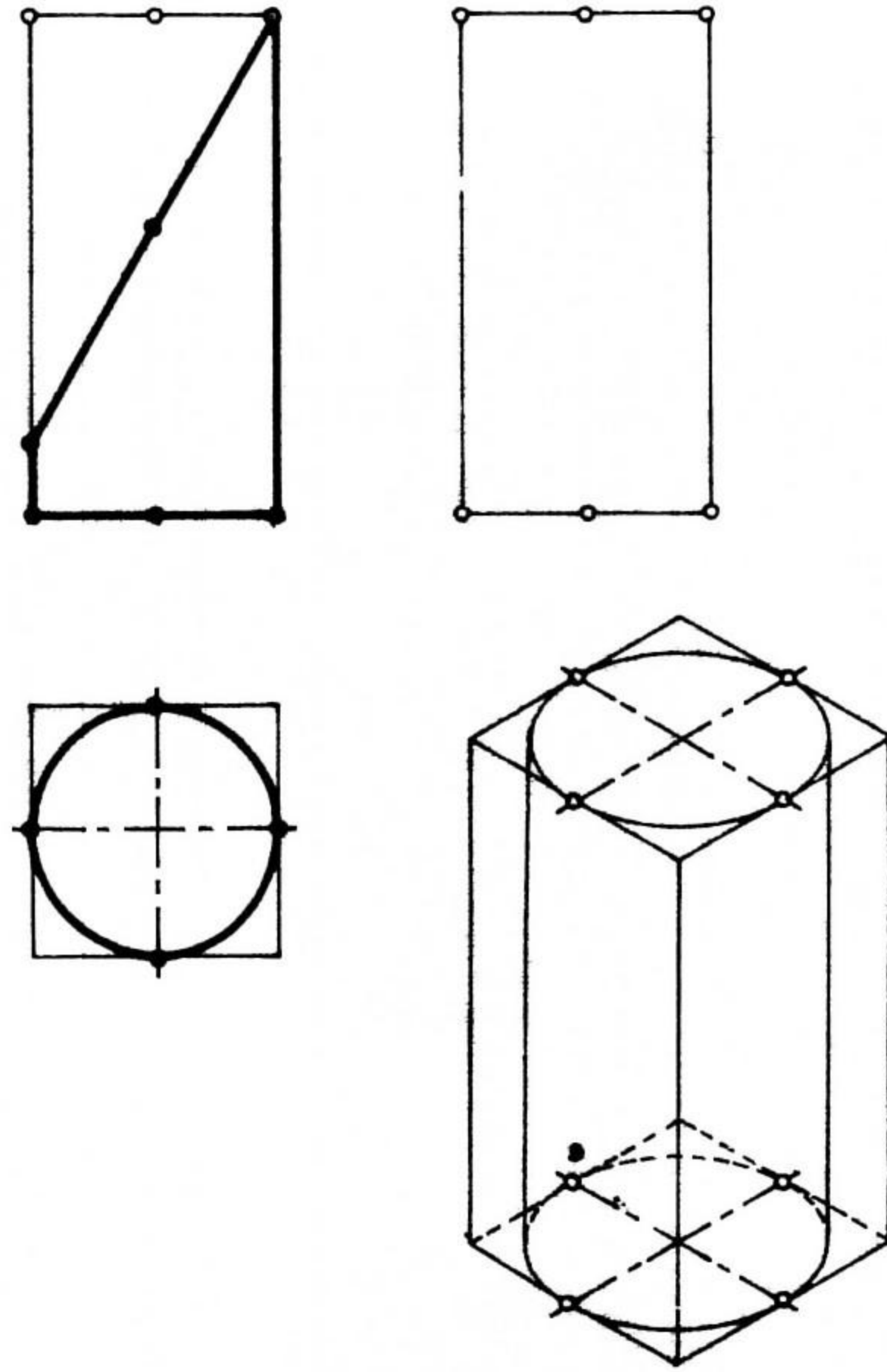

DPTO. DISEÑO BASICO

ISPJAE FACULTAD DE ARQUITECTURA

ASIGNATURA	TEMA		
DOC.	ALUM.	No.	GPO.
FECHA		EVAL.	



6.2 CILINDRO CIRCULAR TRUNCADO - VISIBILIDAD - DESARROLLO

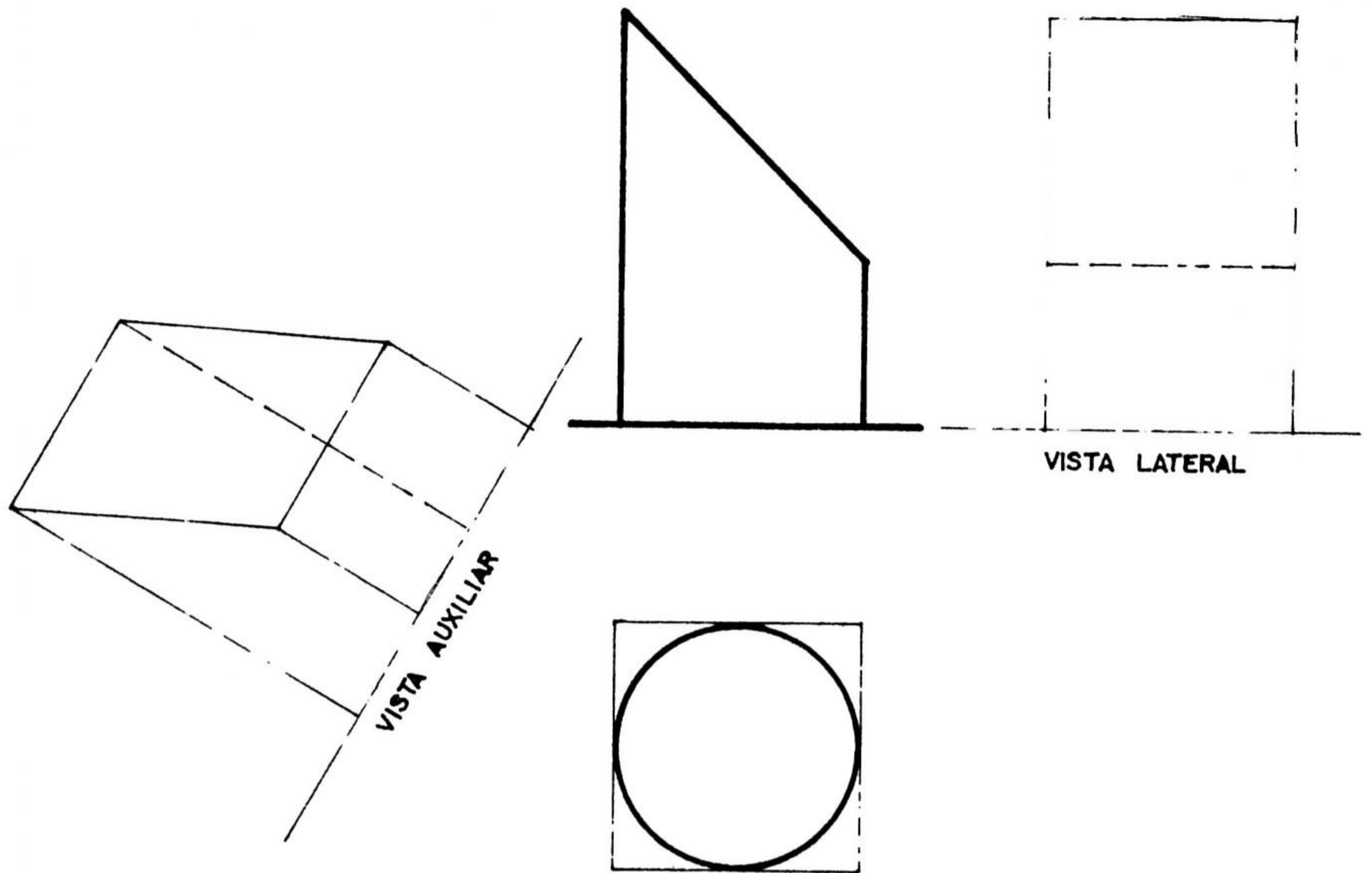

CONSTRUIR EL DESARROLLO DEL CILINDRO CIRCULAR TRUNCADO.

DPTO. DISEÑO BASICO		ISPJAE		D D D
		FACULTAD DE ARQUITECTURA		
ASIGNATURA	TEMA	No.	GPO.	
DOC.	ALUM.	FECHA	EVAL.	

6.2.3 SUPERFICIES CILÍNDRICAS- INTERPRETACIÓN

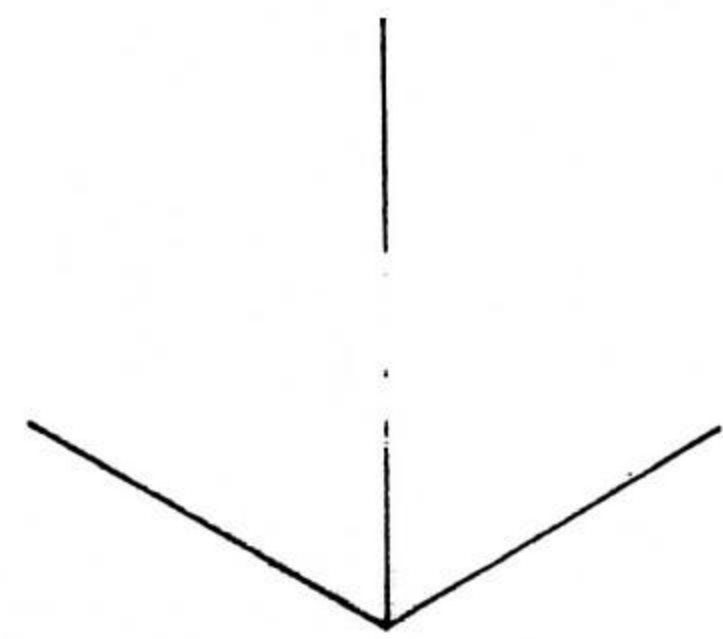
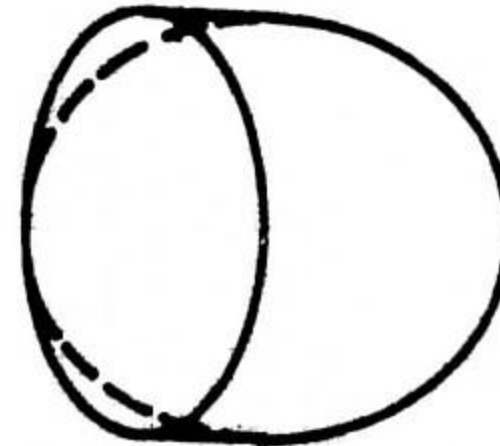
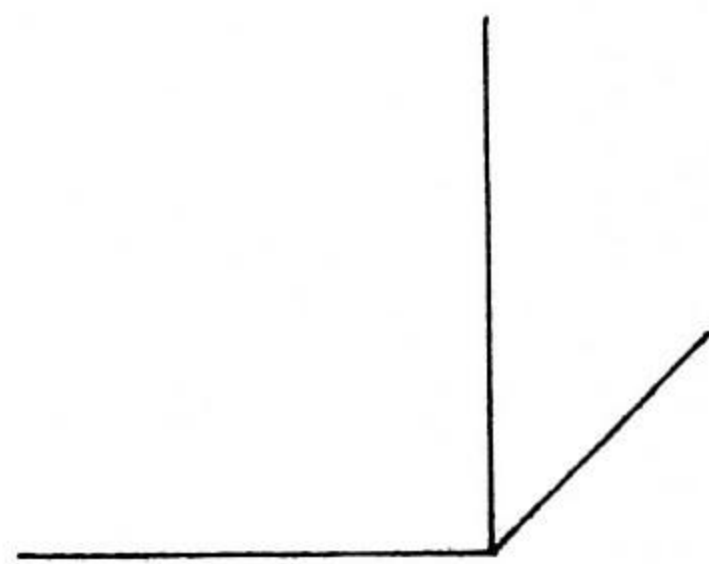
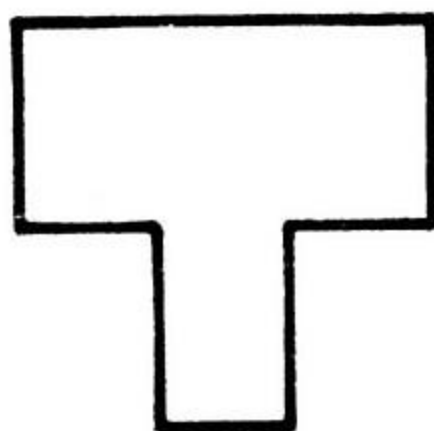
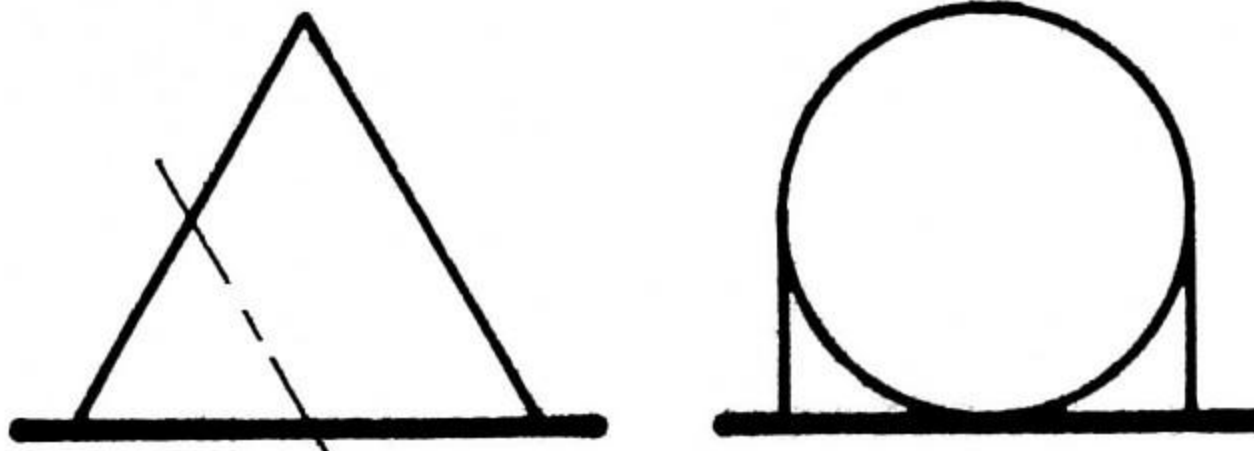
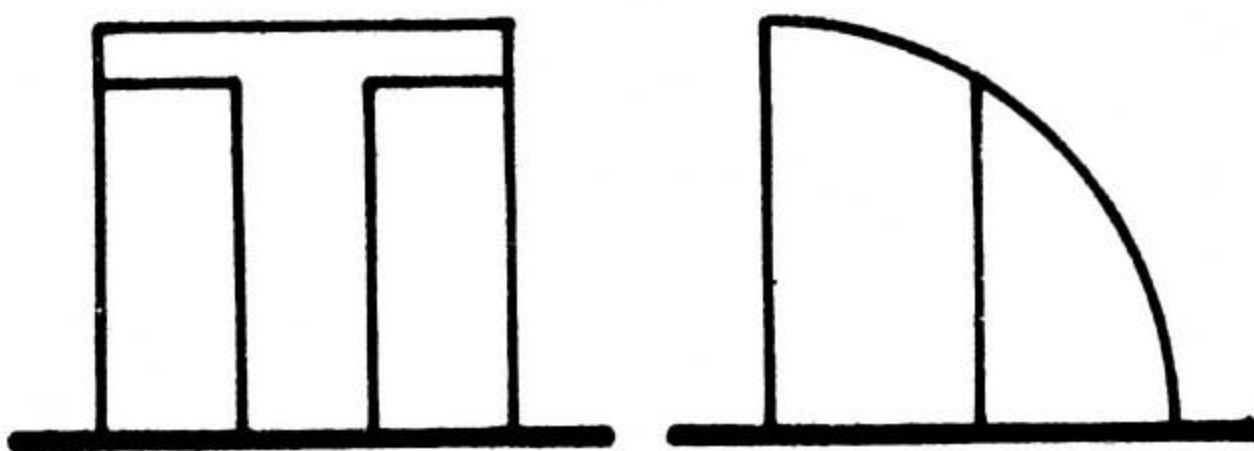
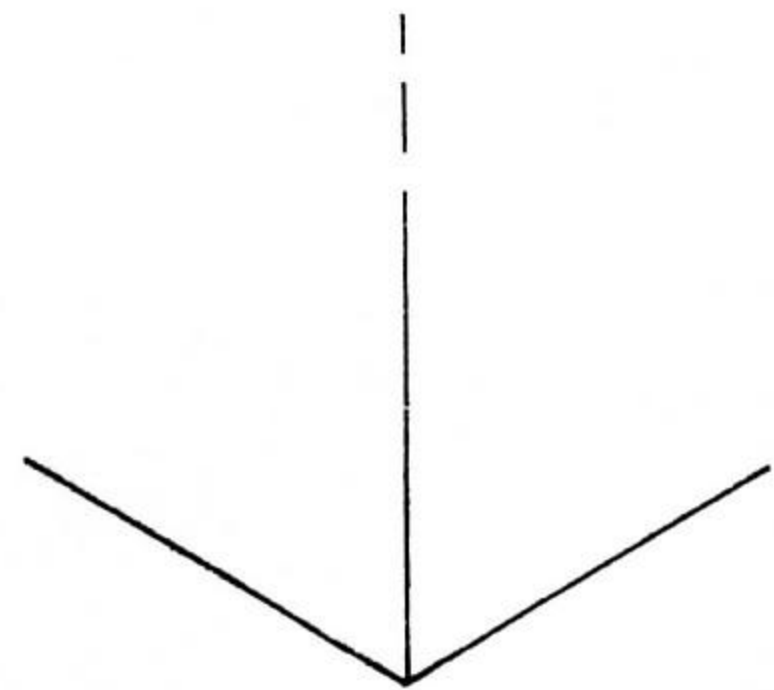
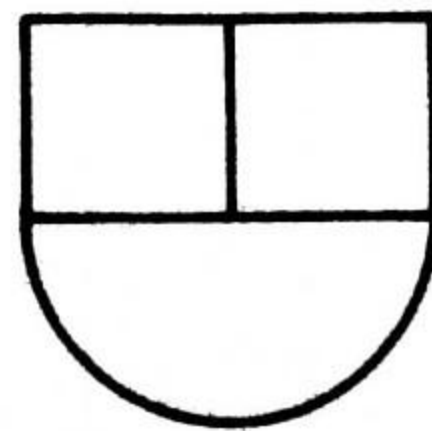
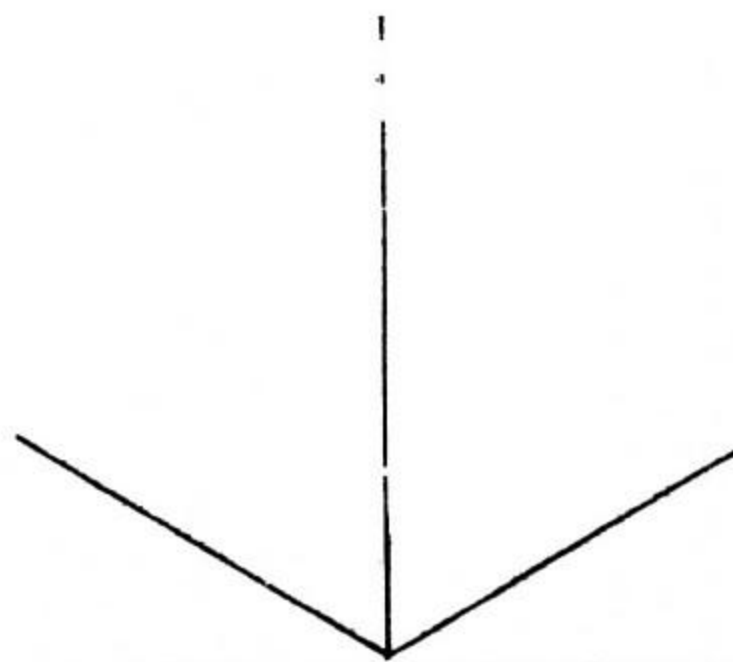
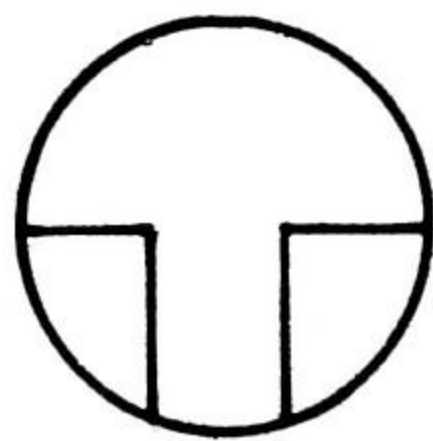
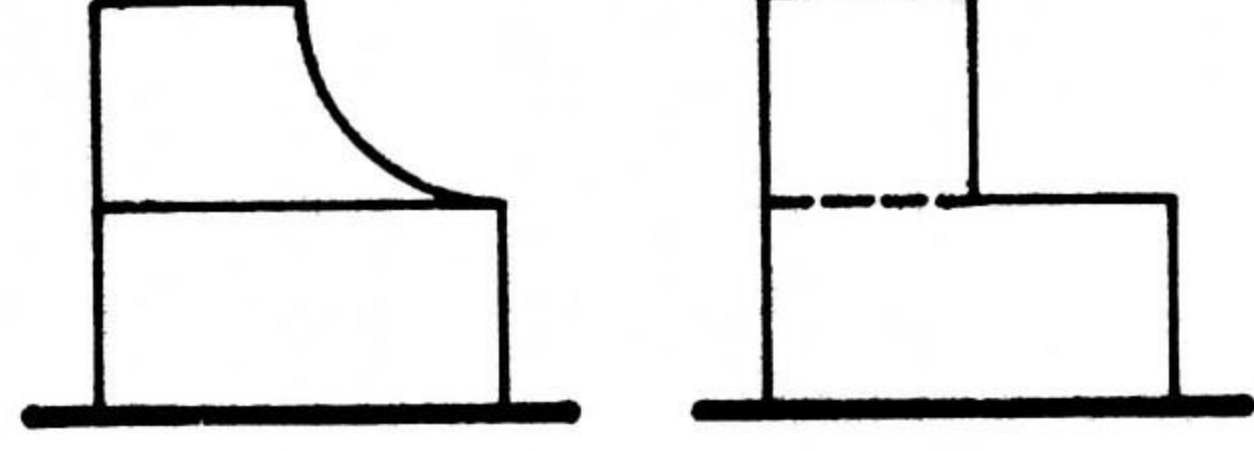
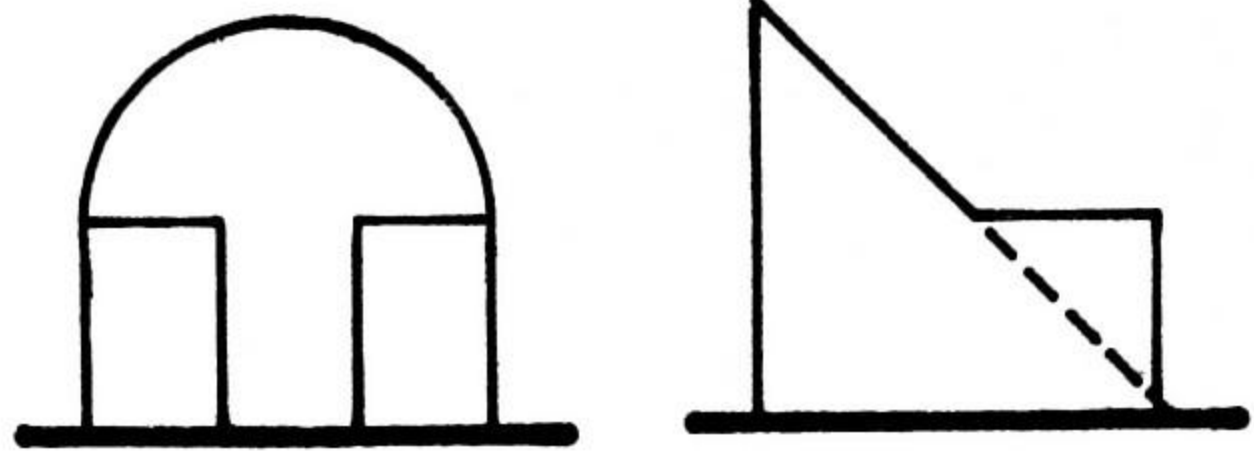
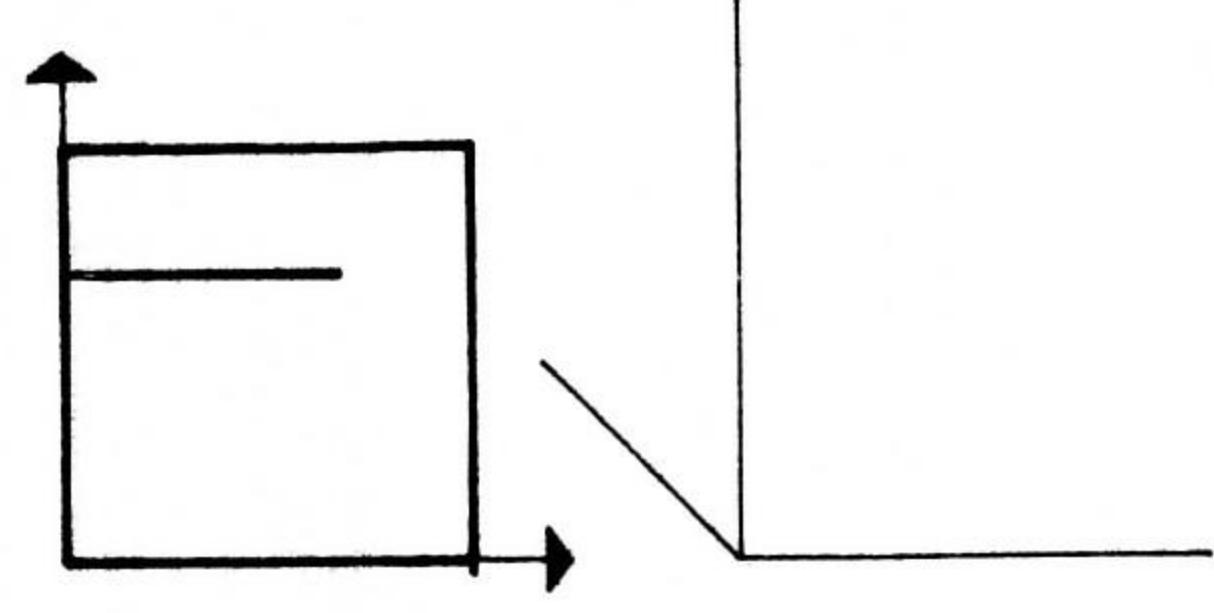
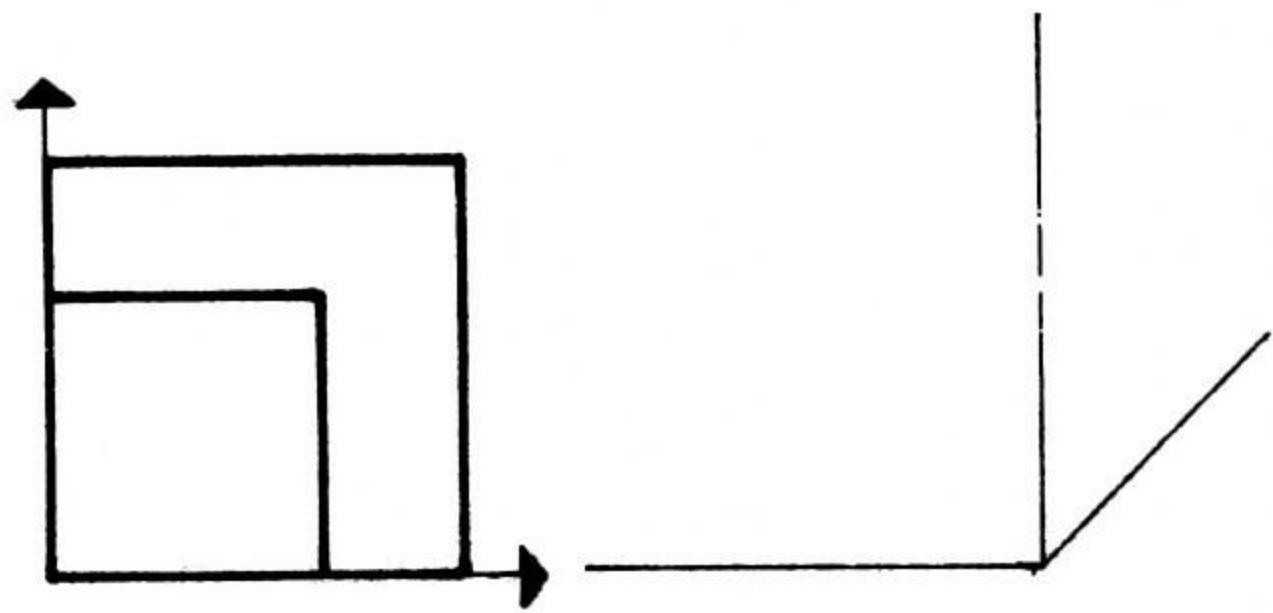
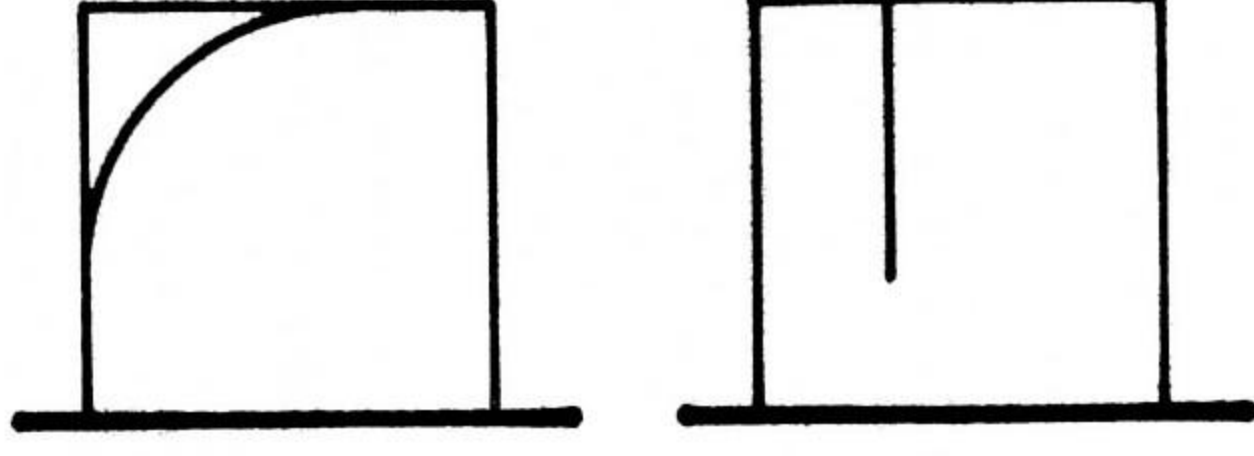
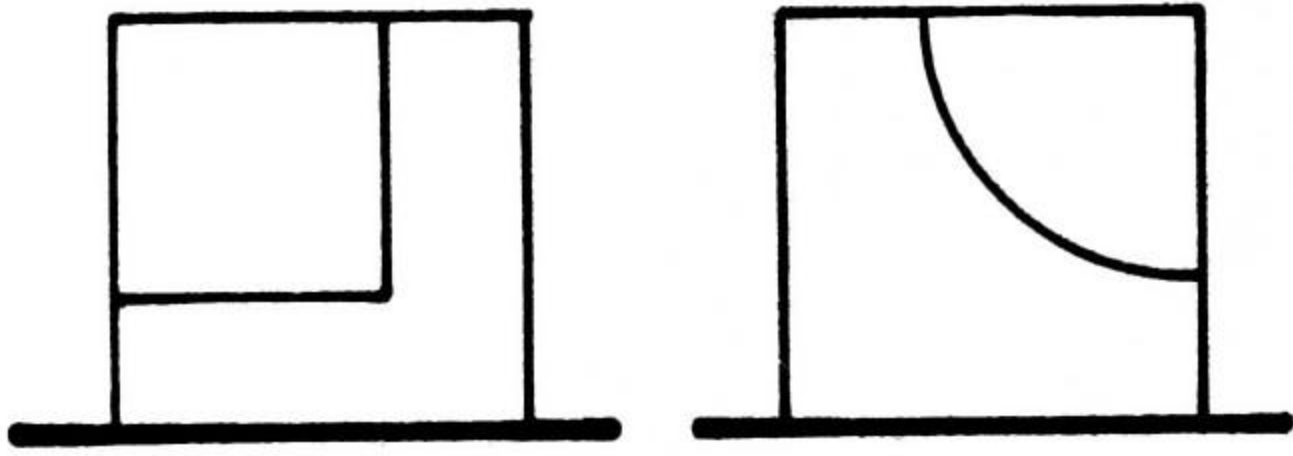

DPTO. DISEÑO BASICO

ISPJAE FACULTAD DE ARQUITECTURA

ASIGNATURA

TEMA

DOC.

ALUM.

No.

OPC.

FECHA

EVAL.

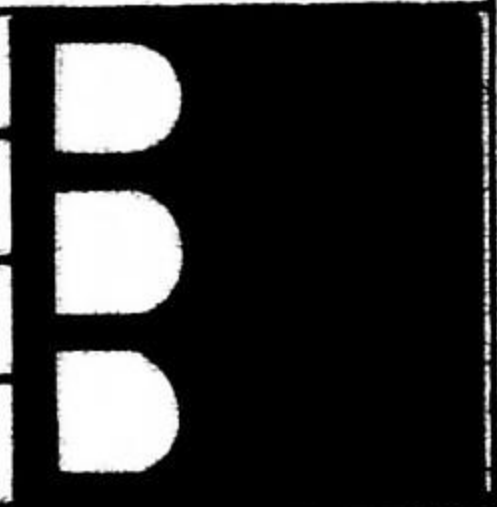

6.3 CONO: TIPO, POSICION, CONTORNOS Y REGIONES

A

CONO _____
 POSICION _____

PERCEPCION DE LAS GENERATRICES

V-2 y V-4 | EN V DE F _____
 | EN V SUP. _____

V-1 y V-3 | EN V DE F _____
 | EN V SUP _____

REGION ANTERIOR DE LA SUPERFICIE CONICA.

B

CONO _____
 POSICION _____

PERCEPCION DE LOS DIAMETROS DE LA BASE

1-3 | EN V. DE F _____
 | EN V. SUP _____

2-4 | EN V. DE F _____
 | EN V. SUP _____

REGION SUPERIOR

C

CONO _____
 POSICION _____

PERCEPCION DE LAS GENERATRICES

V-2 y V-4 | EN V. DE F. _____
 | EN V. SUP _____

V-1 y V-3 | EN V DE F _____
 | EN V SUP. _____

REGION SUPERIOR

D

CONO _____
 POSICION _____

PERCEPCION DE LAS GENERATRICES

V-2 y V-4 | EN V. DE F. _____
 | EN V. SUP _____

V-1 y V-3 | EN V. DE F. _____
 | EN V SUP. _____

REGION ANTERIOR

E

CONO _____
 POSICION _____

PERCEPCION DE LOS DIAMETROS DE LA BASE

1-3 | EN V DE F _____
 | EN V SUP _____

2-4 | EN V. DE F. _____
 | EN V. SUP. _____

REGION SUPERIOR

F

CONO _____
 POSICION _____

PERCEPCION DE LAS GENERATRICES

V-2 y V-4 | EN V. DE F. _____
 | EN V. SUP. _____

V-1 y V-3 | EN V. DE F. _____
 | EN V. SUP. _____

REGION ANTERIOR

DPTO. DISEÑO BASICO		ISPJAE FACULTAD DE ARQUITECTURA	
ASIGNATURA	TEMA		
DOC.	ALUM.	No.	OPC.
FECHA		EVAL.	

6.3 CORTES COMO : DIBUJAR LAS VISTAS QUE FALTAN

A

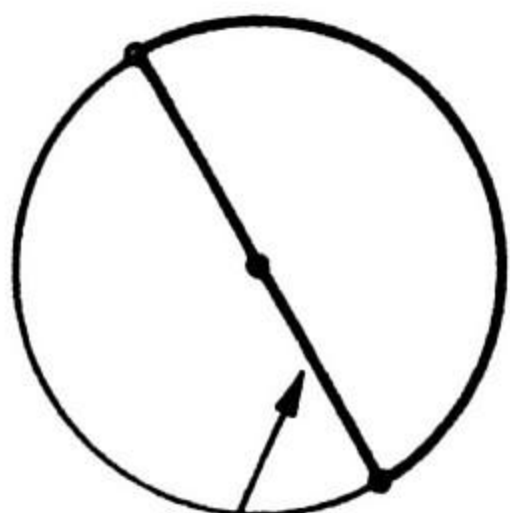
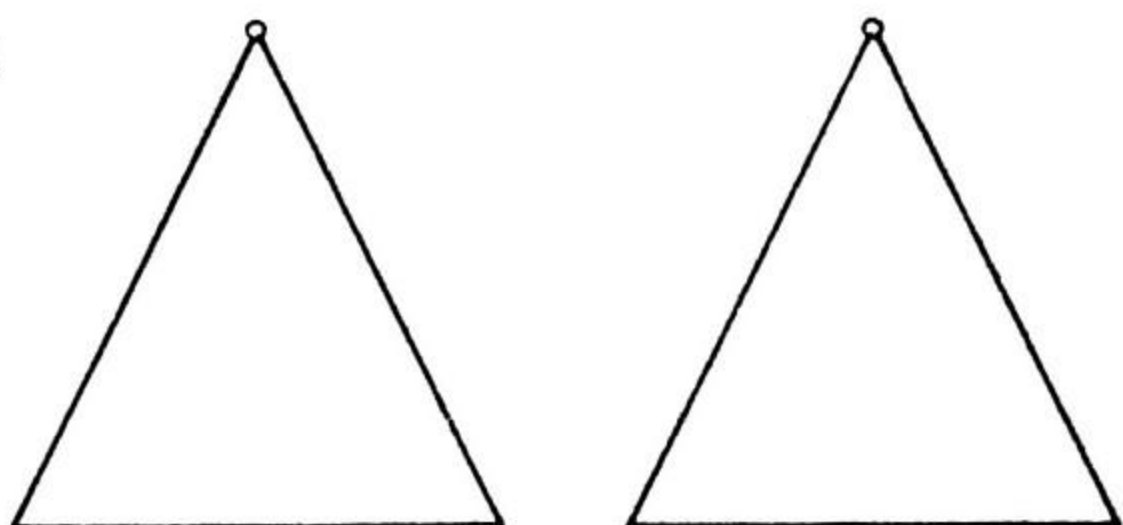

PLANO PROYECTANTE VERTICAL

B

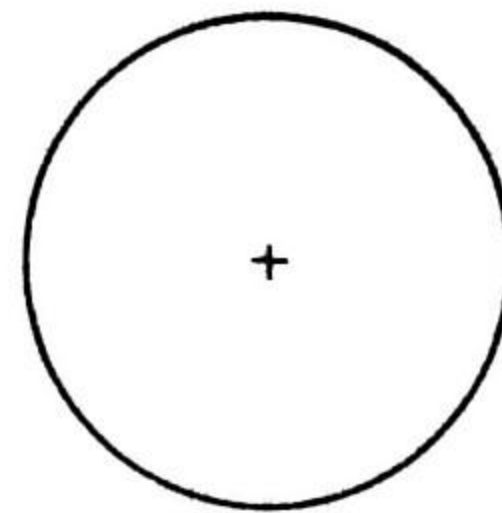
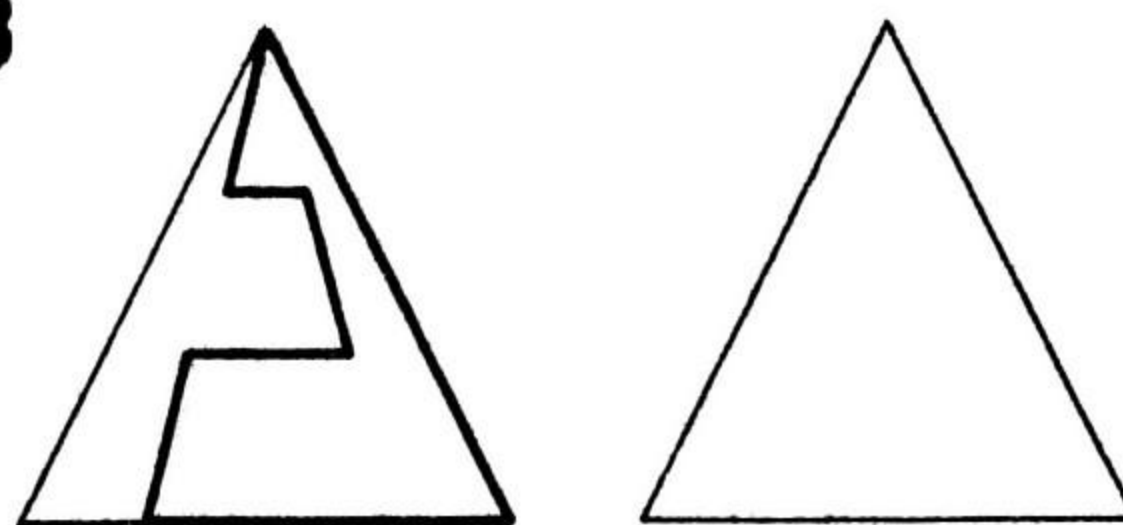

C

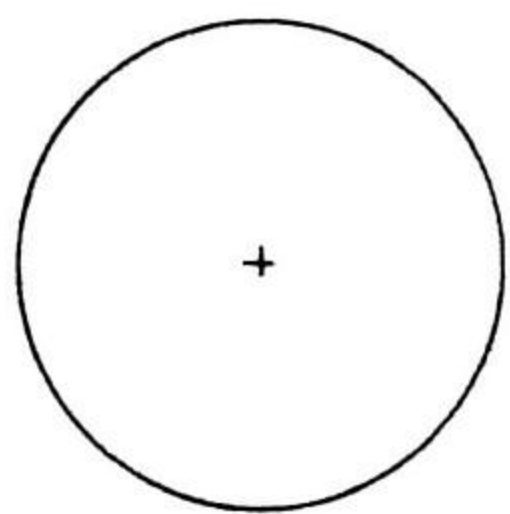
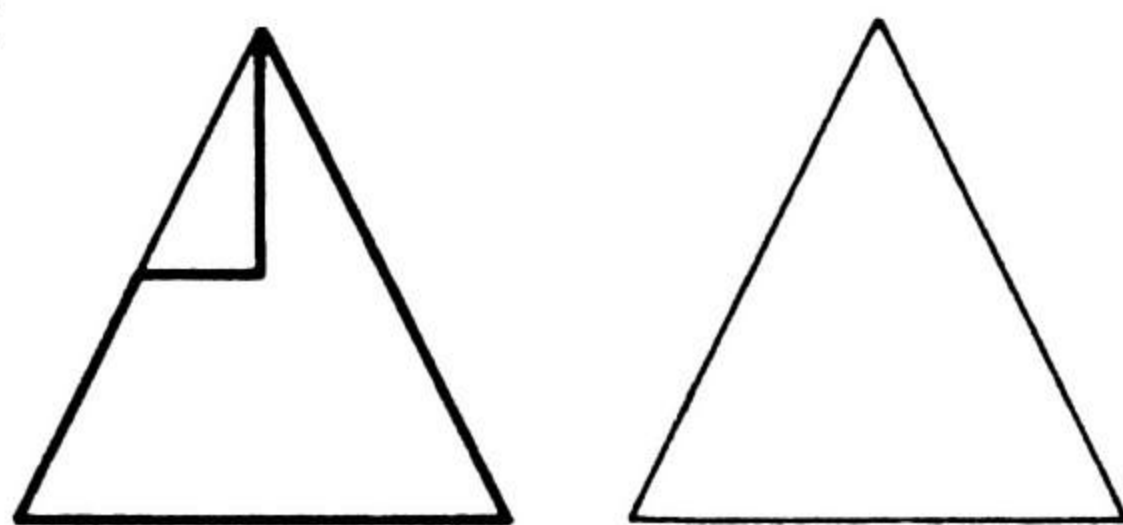

D

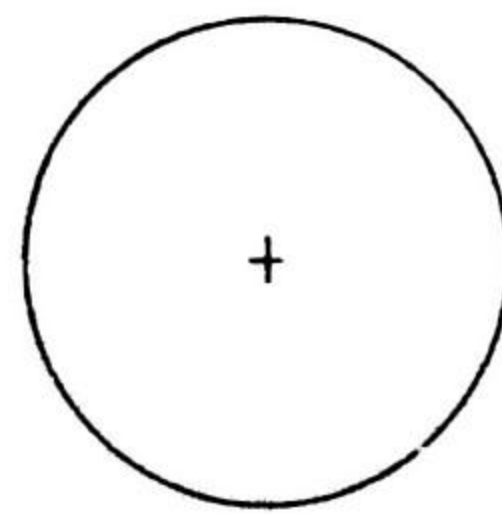
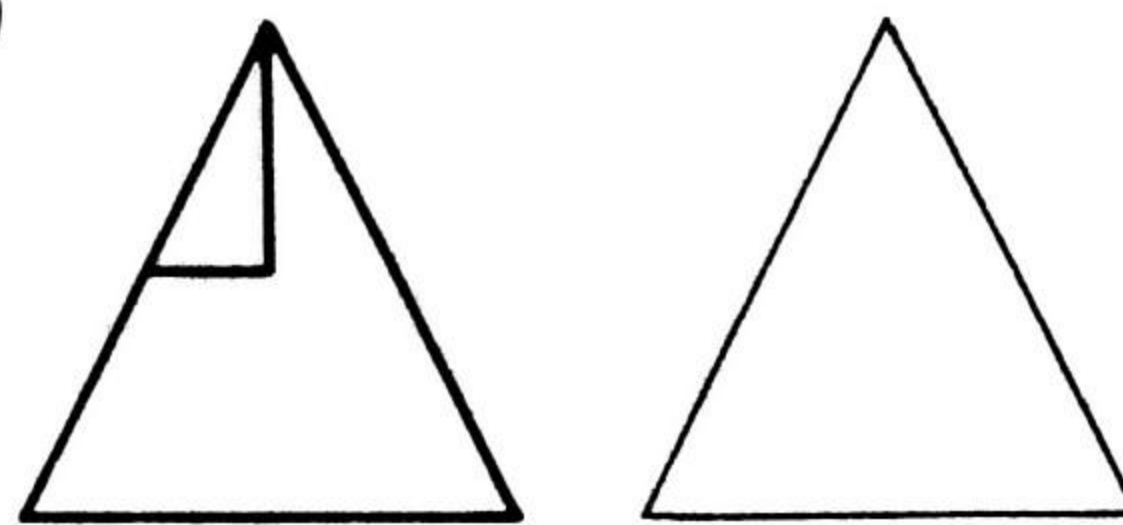

E

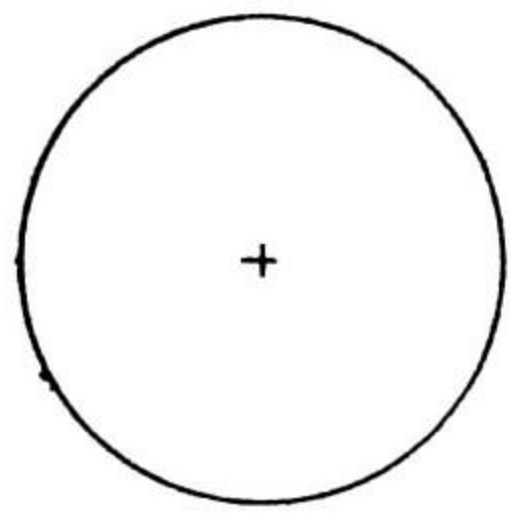
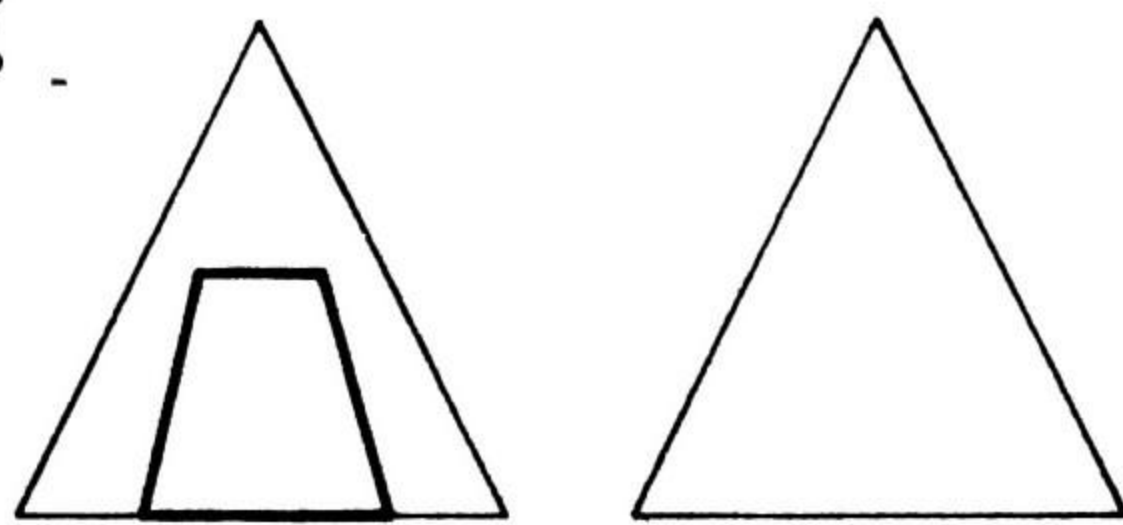

F

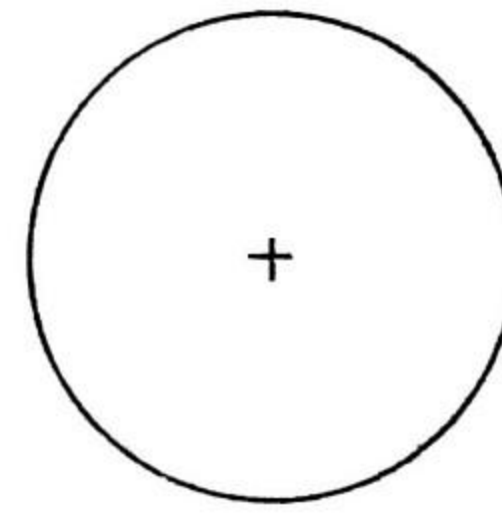
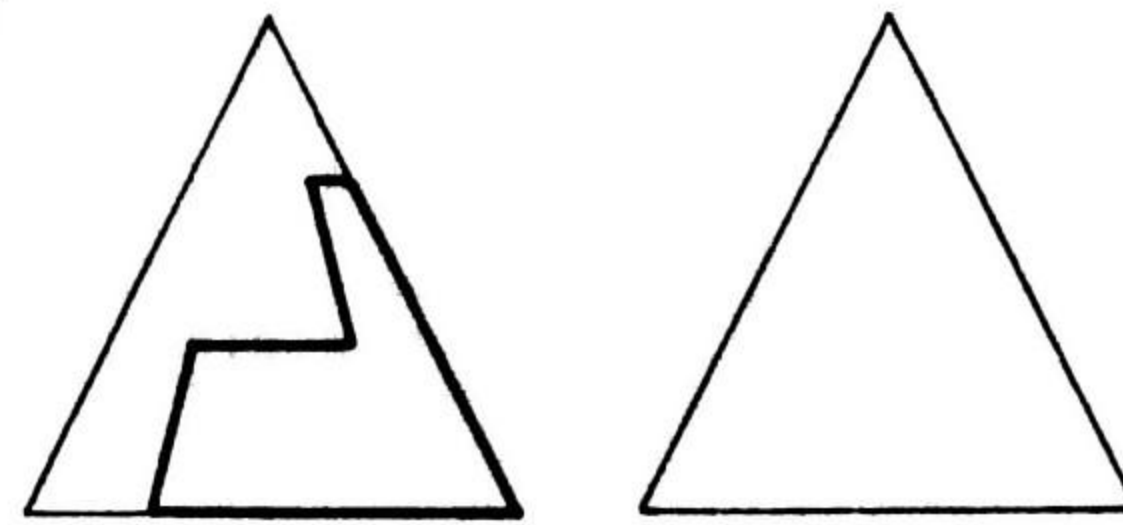

DPTO. DISEÑO BASICO

ISPJAE FACULTAD DE ARQUITECTURA

ASIGNATURA

TEMA

DOC.

ALUM.

No.

GRUPO

FECHA

EVAL.



6.3 CONO: SECCIONES

CONSTRUIR LAS VISTAS FALTANTES DE LA SUPERFICIE CONICA.
(FORMA LAMINAR). HACER EL DESARROLLO EN HOJA APARTE.

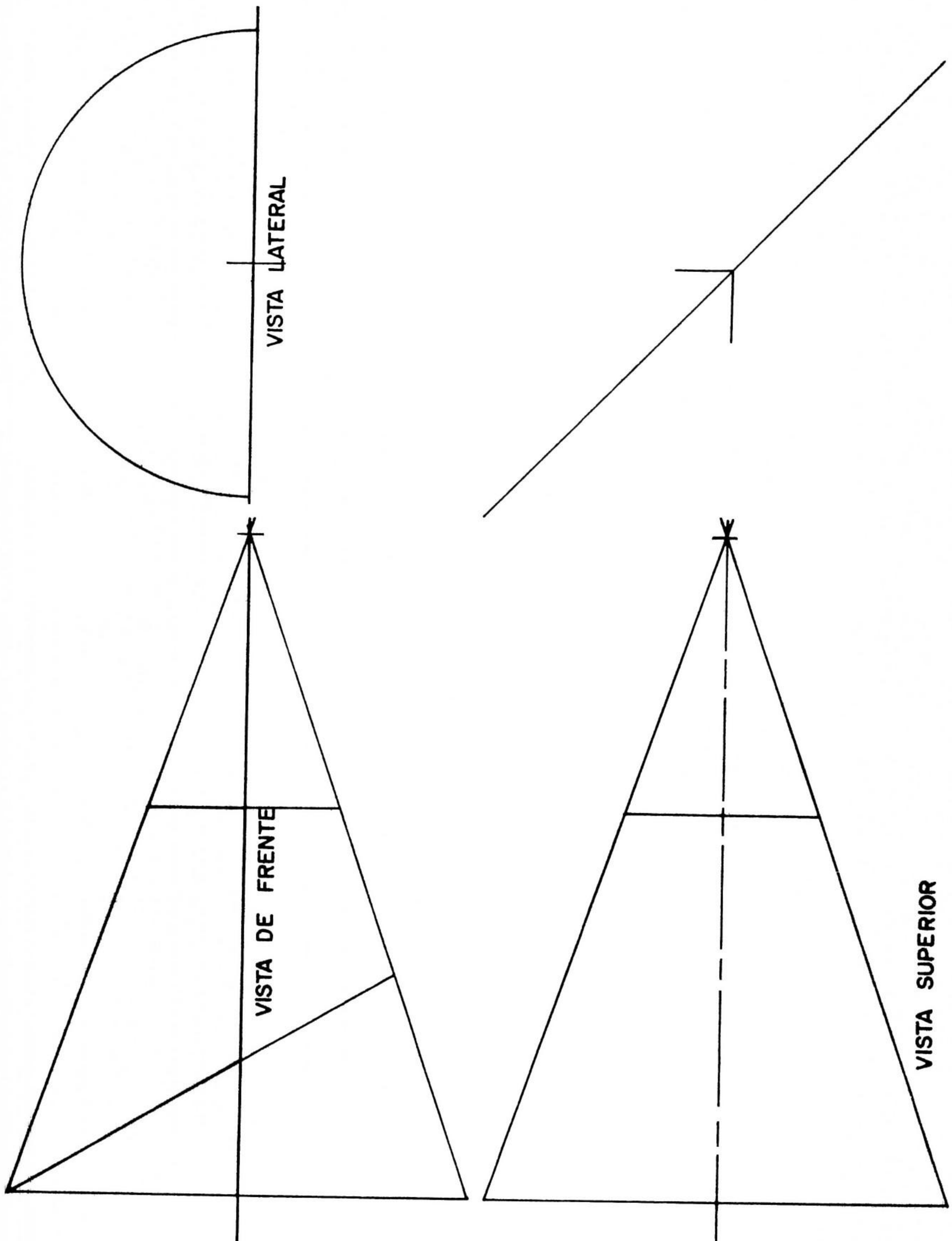

DPTO. DISEÑO BASICO		ISPJAE FACULTAD DE ARQUITECTURA	
ASIGNATURA	TEMA		
DOC.	ALUM.	No.	GRPO.
FECHA			EVAL.

6.4 INTERSECCIONES DE CILINDROS

A

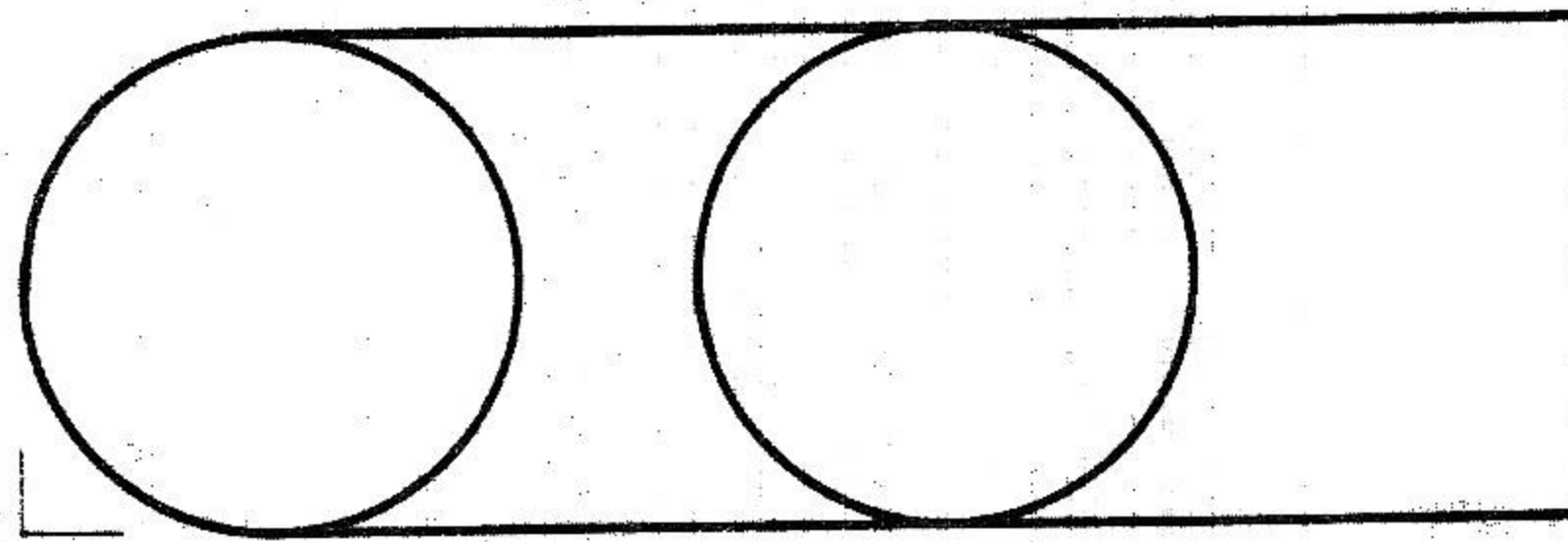
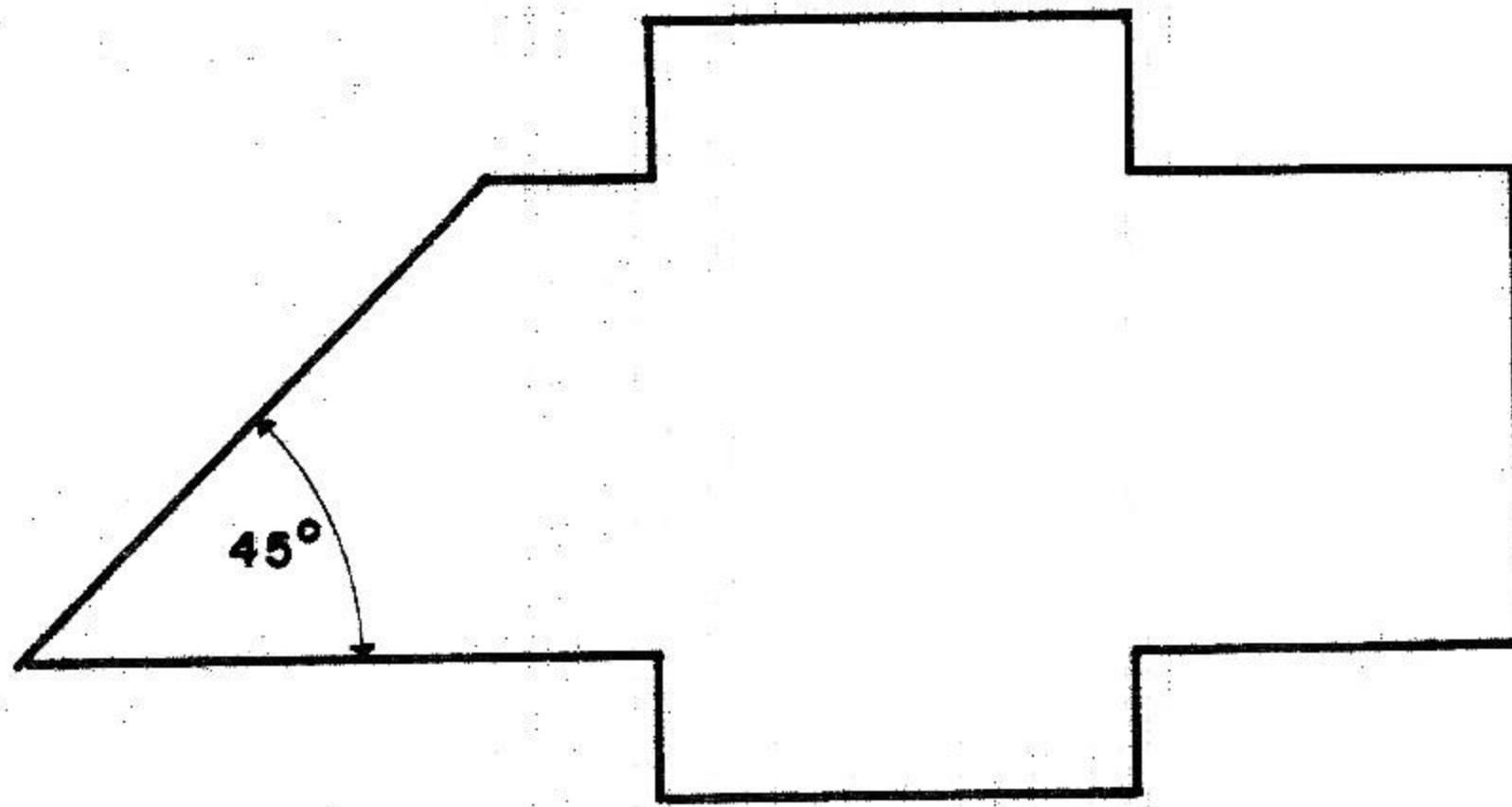

CILINDROS CIRCULARES

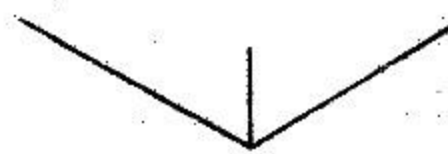

ISOMETRICO

DPTO. DISEÑO BASICO		ISPJAE	
		FACULTAD DE ARQUITECTURA	
ASIGNATURA	TEMA		
DOC.	ALUM.	No.	GPO.
FECHA		EVAL.	

6.4 INTERSECCIONES DE CILINDROS

B

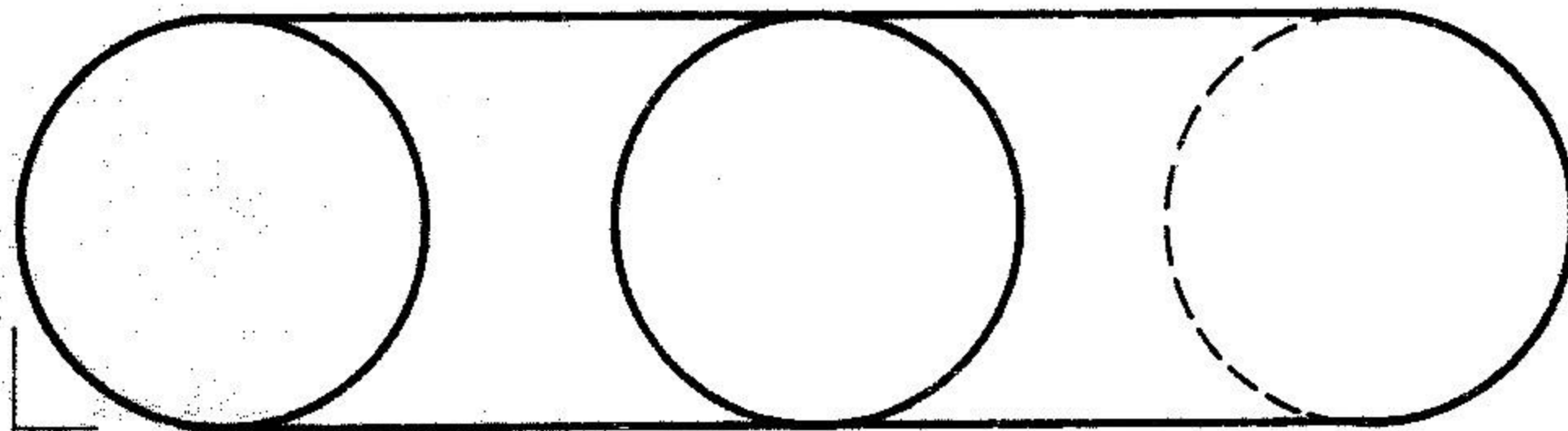
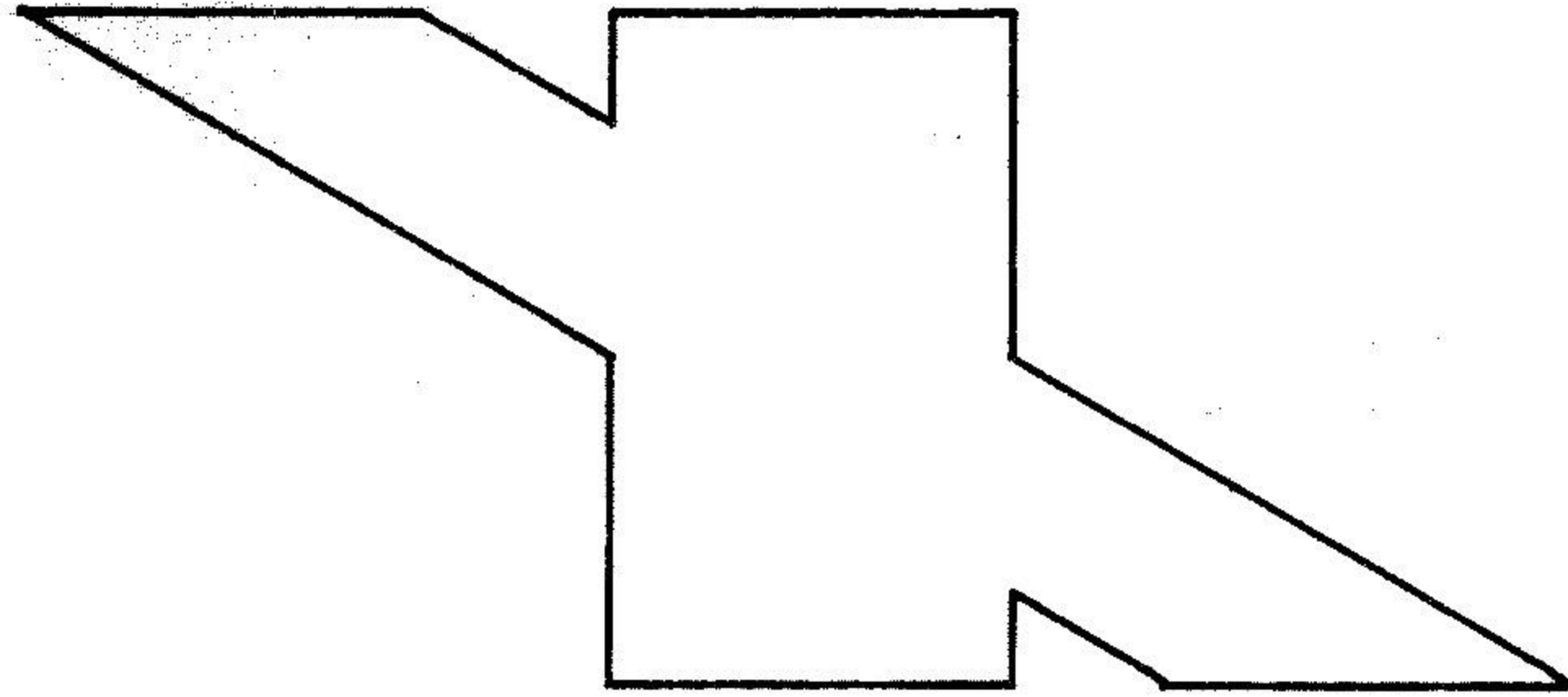

GILINDRO CIRCULAR Y CILINDRO ELIPTICO

ISOMETRICO

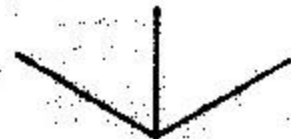

DPTO. DISEÑO BASICO		ISPJAE FACULTAD DE ARQUITECTURA	
ASIGNATURA	TEMA		
DOC.	ALUM.	No.	GRPO.
FECHA		EVAL.	

6.4 BOVEDA DE ARISTA. DIBUJAR LAS VISTAS QUE FALTAN Y LA PERSPECTIVA CABALLERA.

A

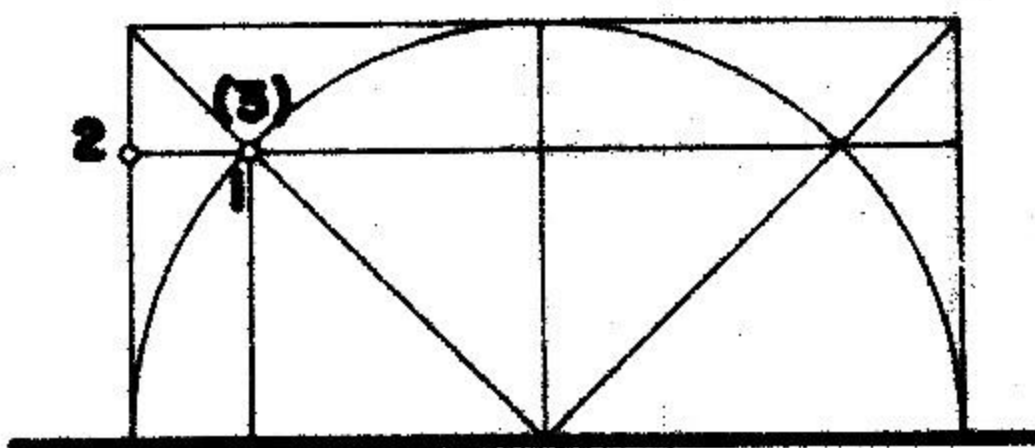

VISTA DE FRENTE

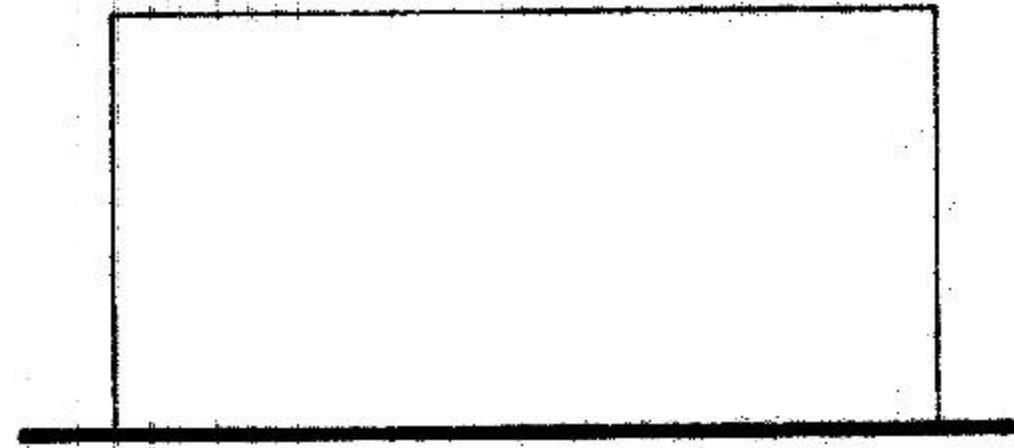

VISTA LATERAL

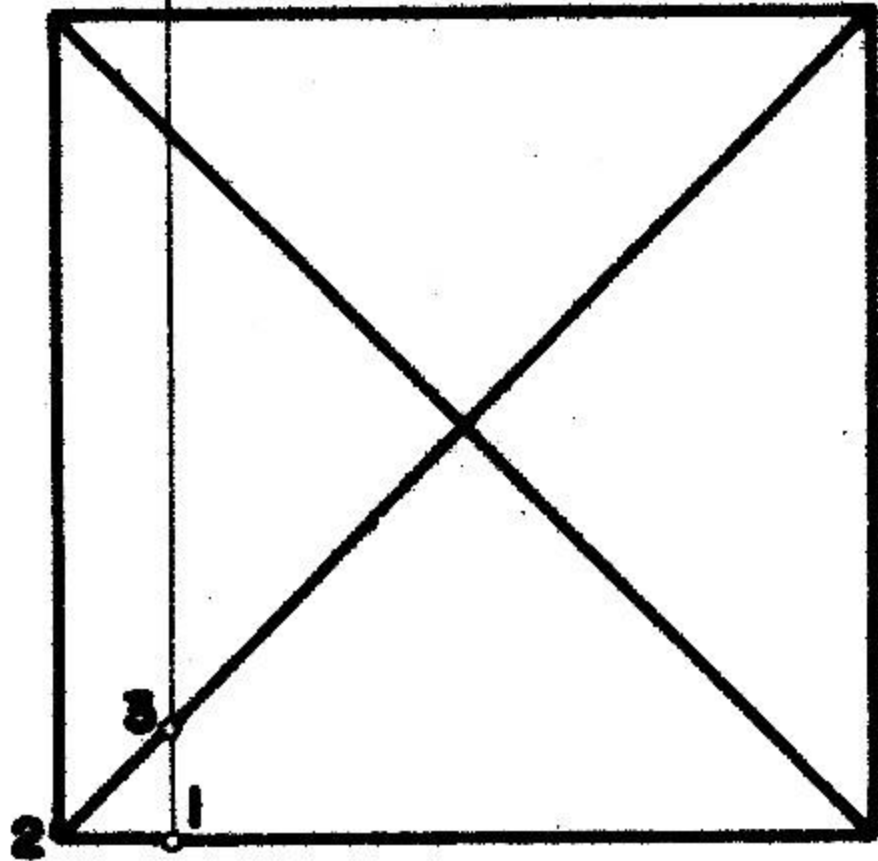

VISTA SUPERIOR

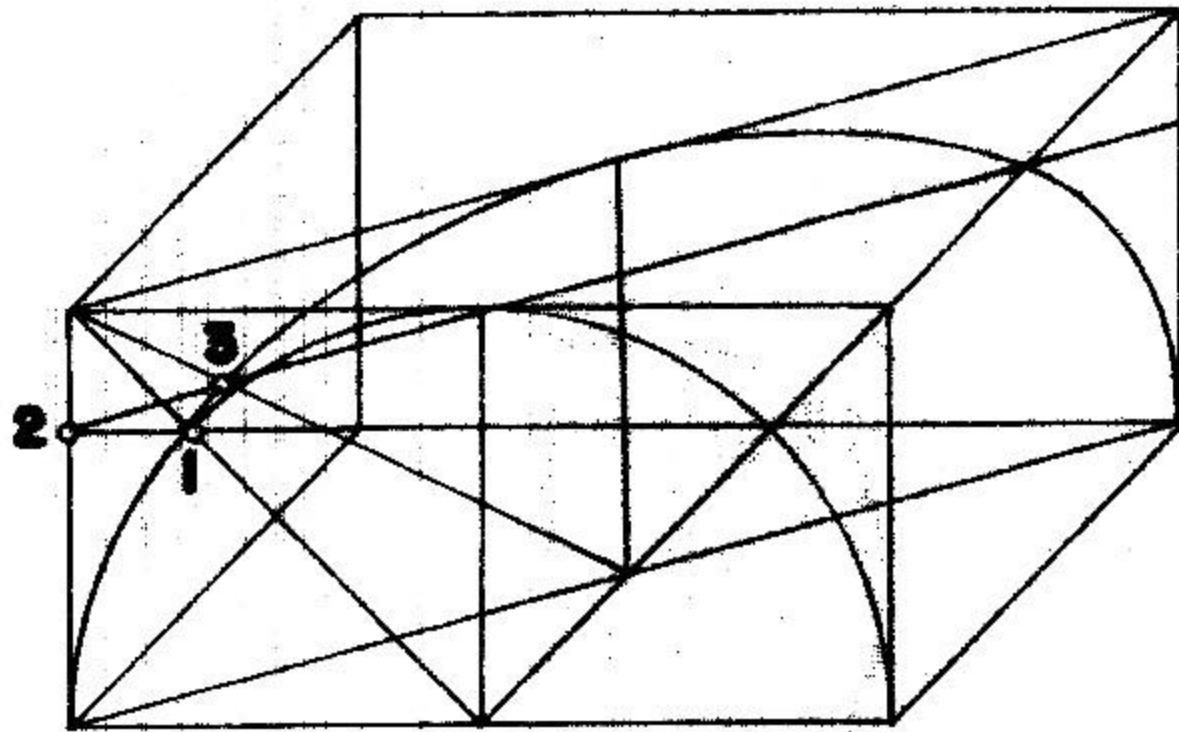

PERSPECTIVA CABALLERA

BOVEDA DE RINCON DE CLAUSTRO. DIBUJAR LAS VISTAS QUE FALTAN Y LA PERSPECTIVA CABALLERA.

B

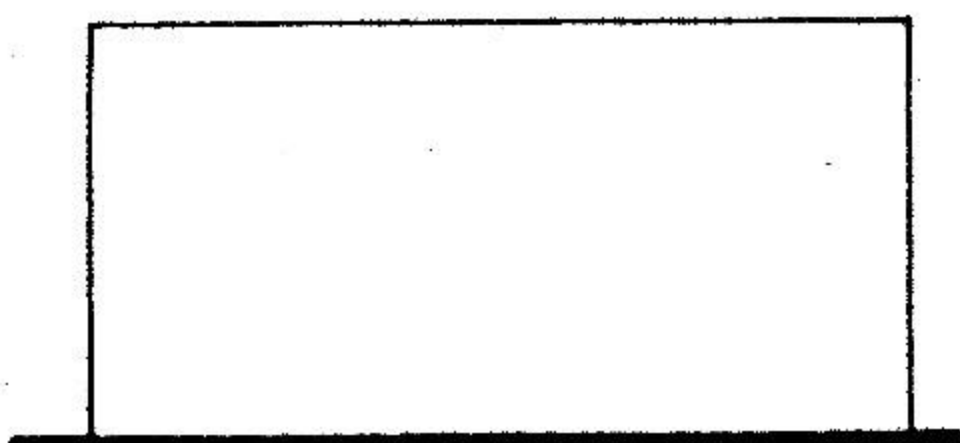

VISTA DE FRENTE

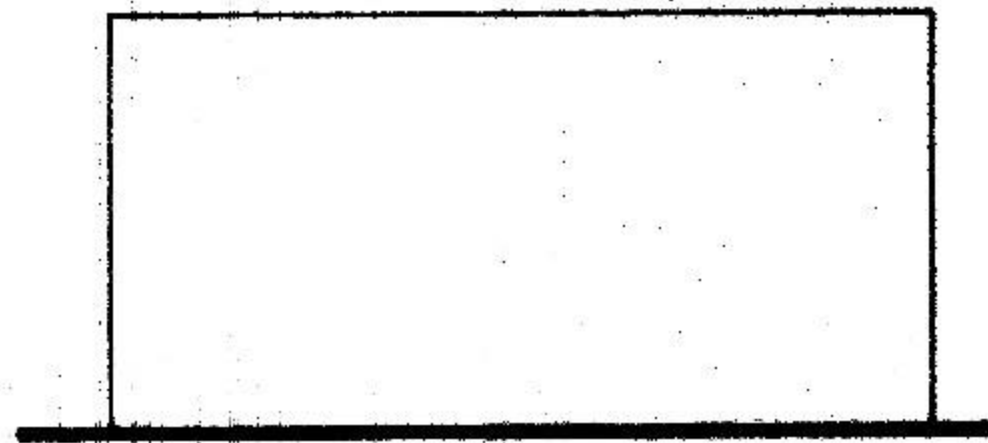

VISTA LATERAL

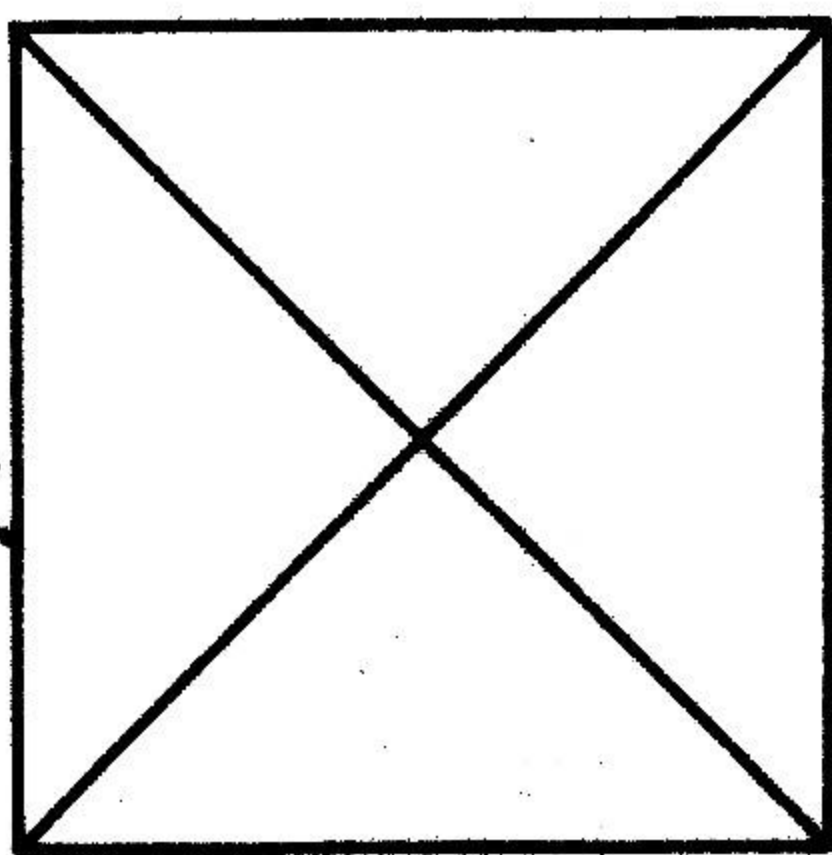

VISTA SUPERIOR

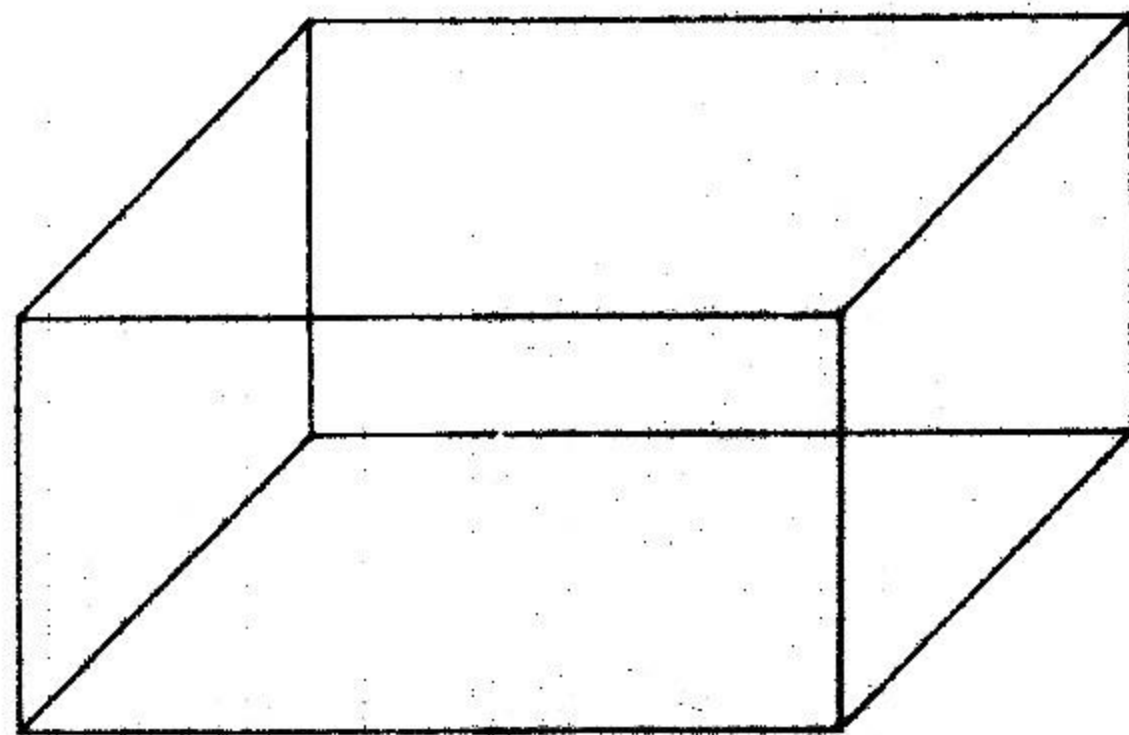

PERSPECTIVA CABALLERA

DPTO. DISEÑO BASICO		ISPJAE FACULTAD DE ARQUITECTURA	
ASIGNATURA	TEMA	No.	GRUPO
DOC.	ALUM.	EVAL.	
FECHA			

6.4 DIBUJAR : VISTA AUXILIAR

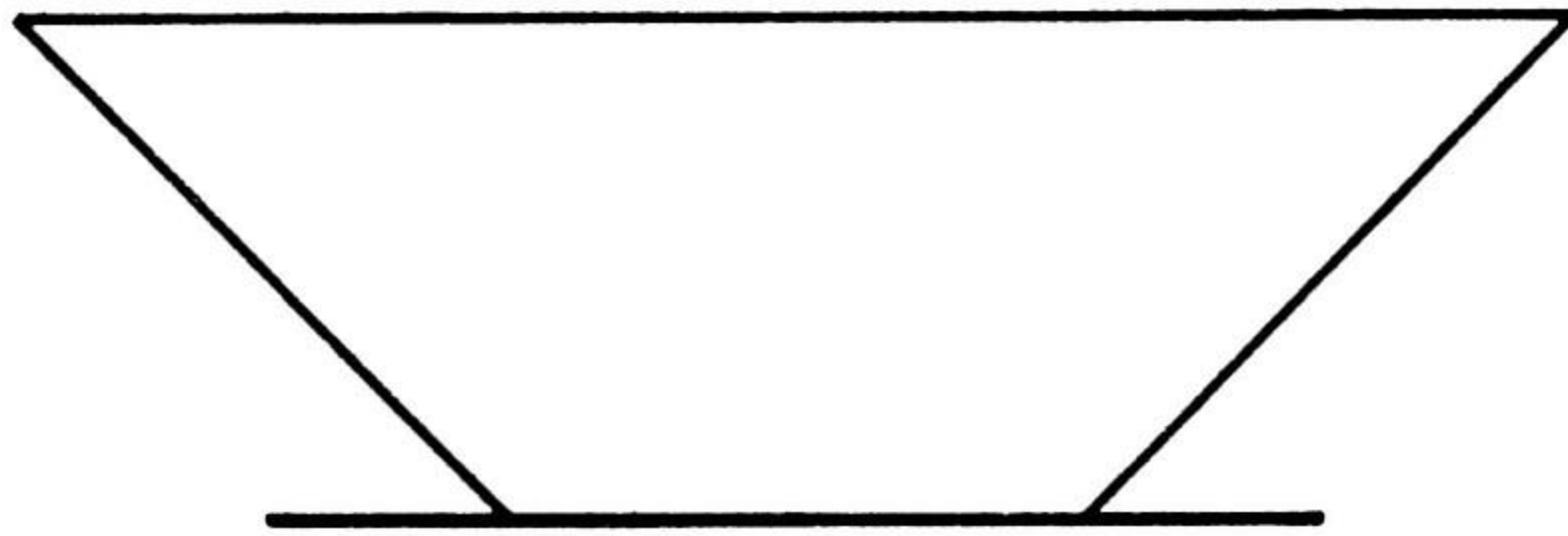

VISTA DE FRENTE

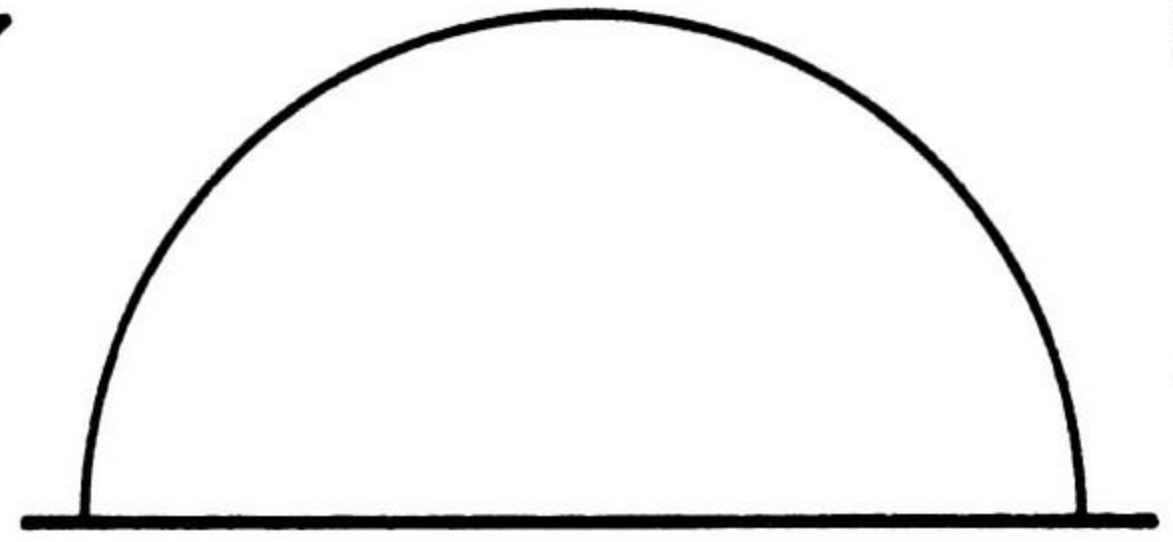

VISTA LATERAL

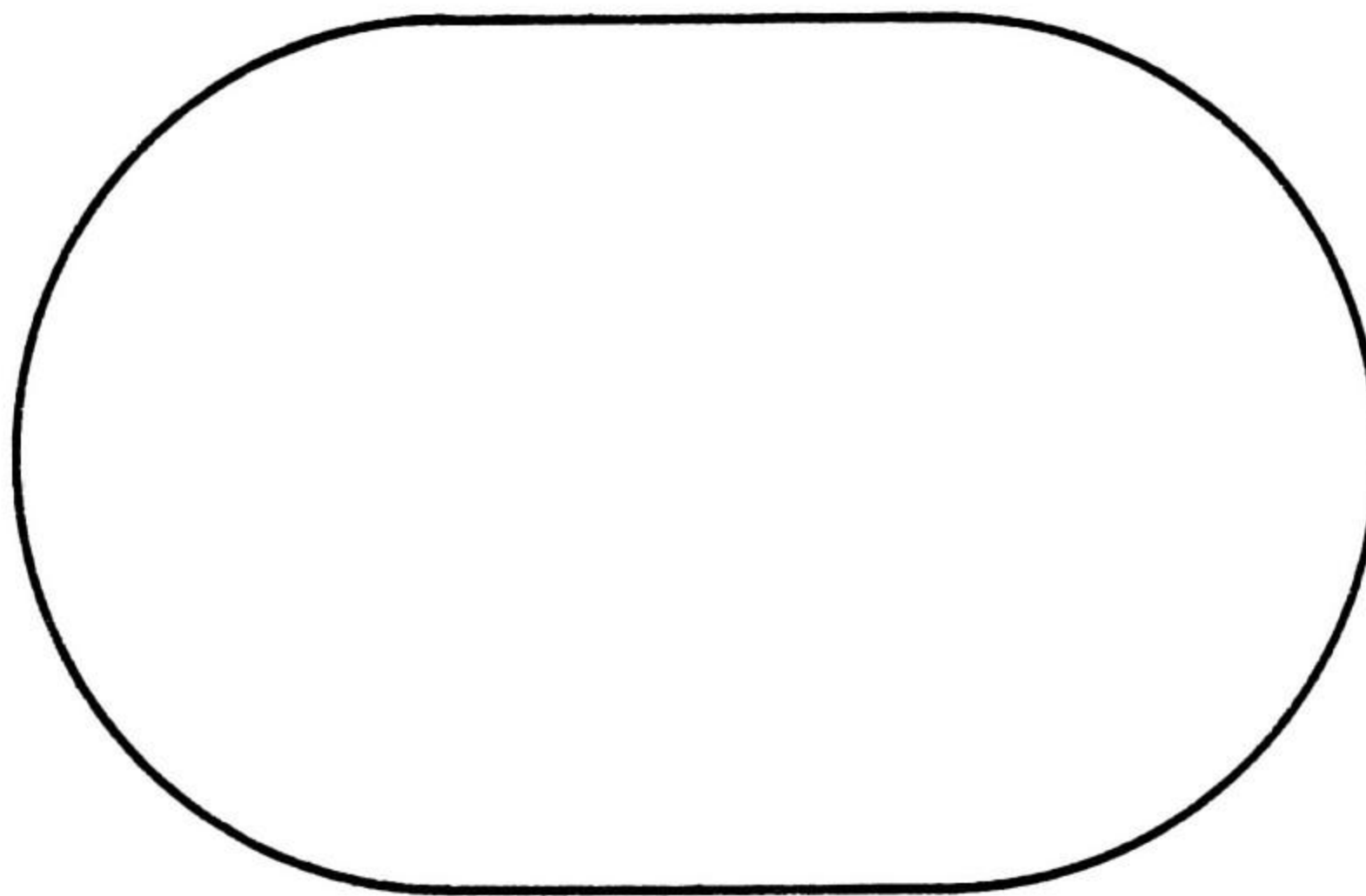

VISTA SUPERIOR

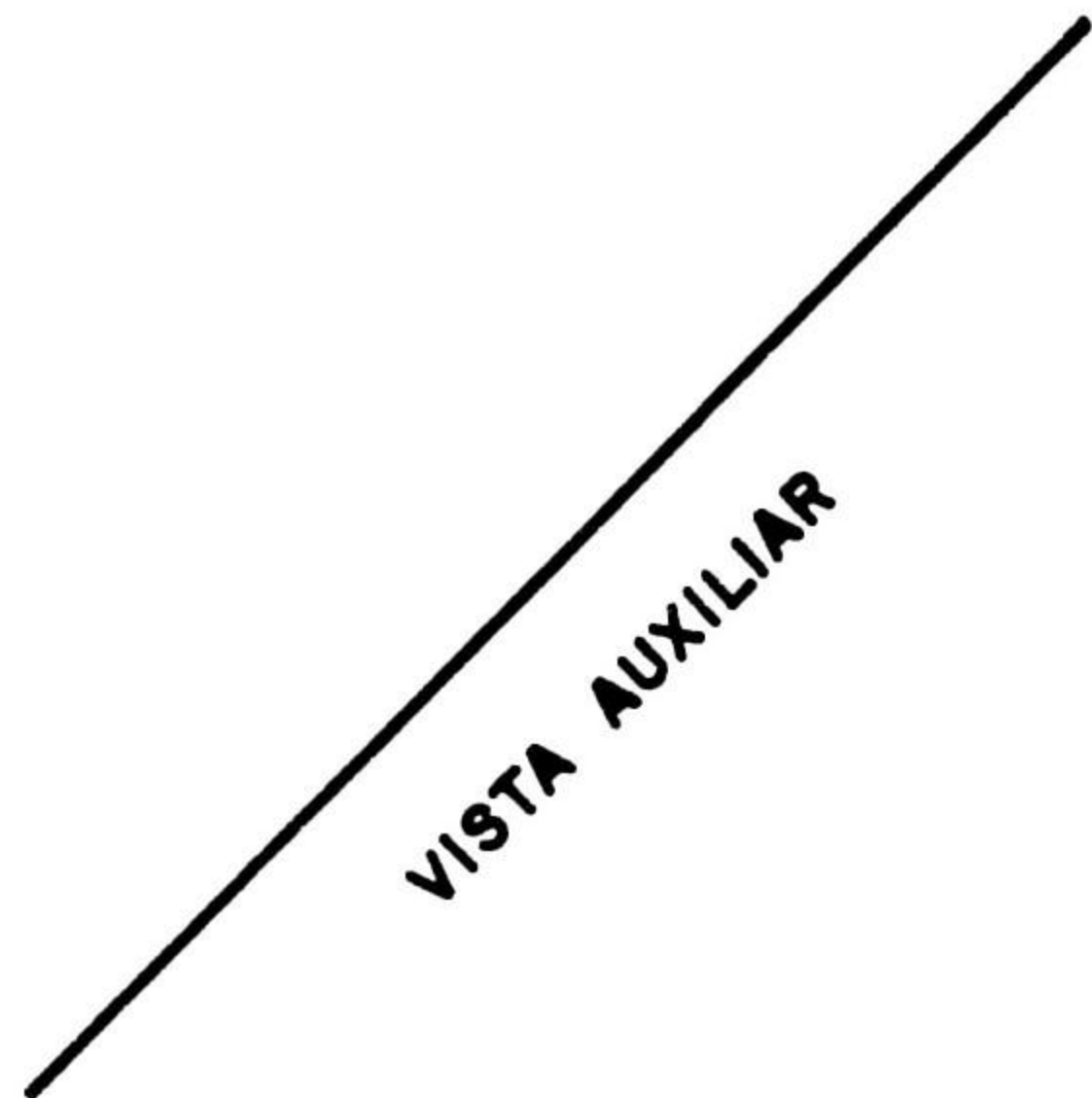

VISTA AUXILIAR

DPTO. DISEÑO BASICO		ISPJAE FACULTAD DE ARQUITECTURA		D D D
ASIGNATURA	TEMA			
DOC.	ALUM.	No.	GRUPO.	
FECHA			EVAL.	

B INTERSECCIONES DE SUPERFICIES CILINDRICAS (FORMA LAMINAR)
Terminar la vista de frente.

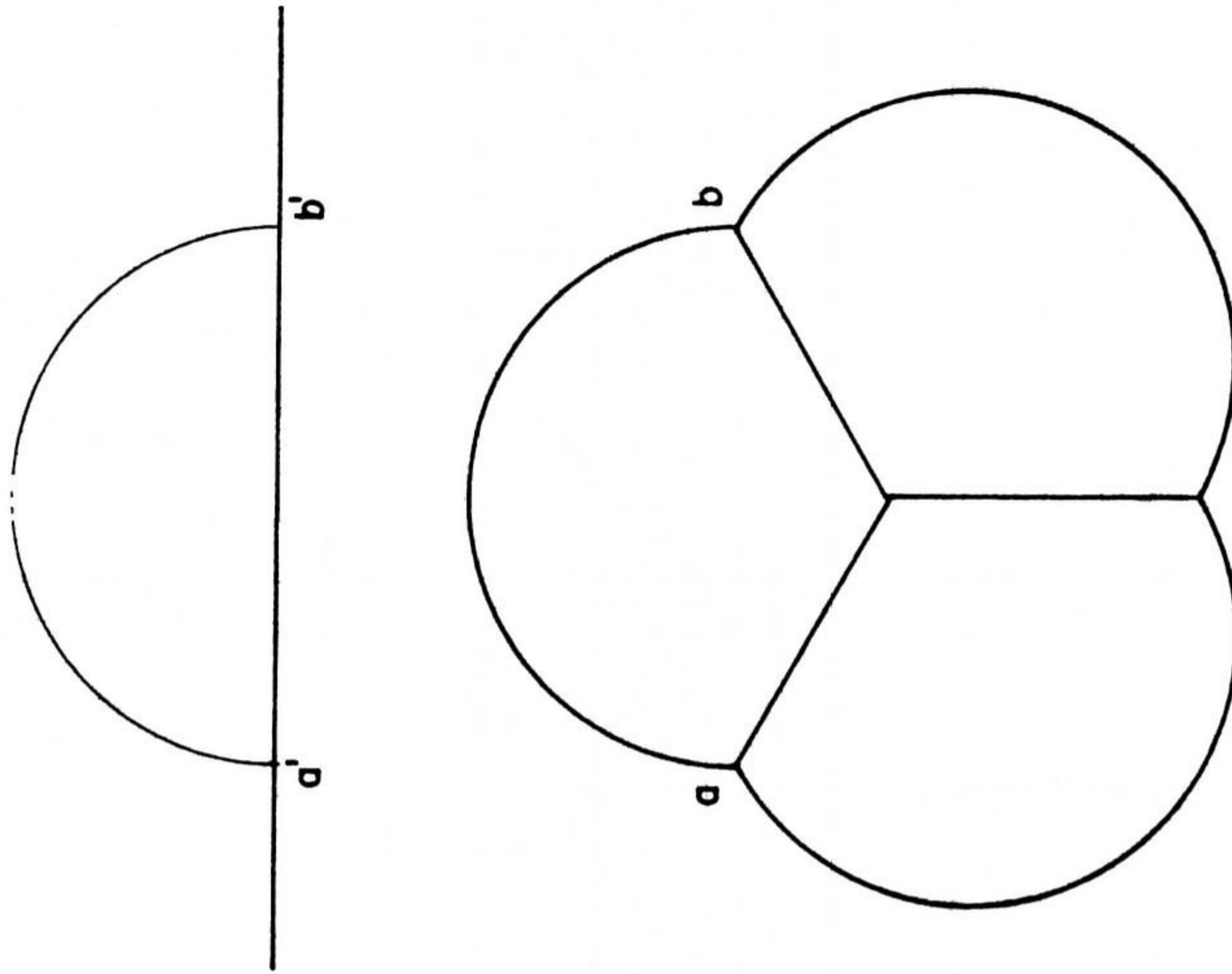

A INTERSECCIONES DE SUPERFICIES CONICAS (FORMA LAMINAR)
Terminar la vista de frente.

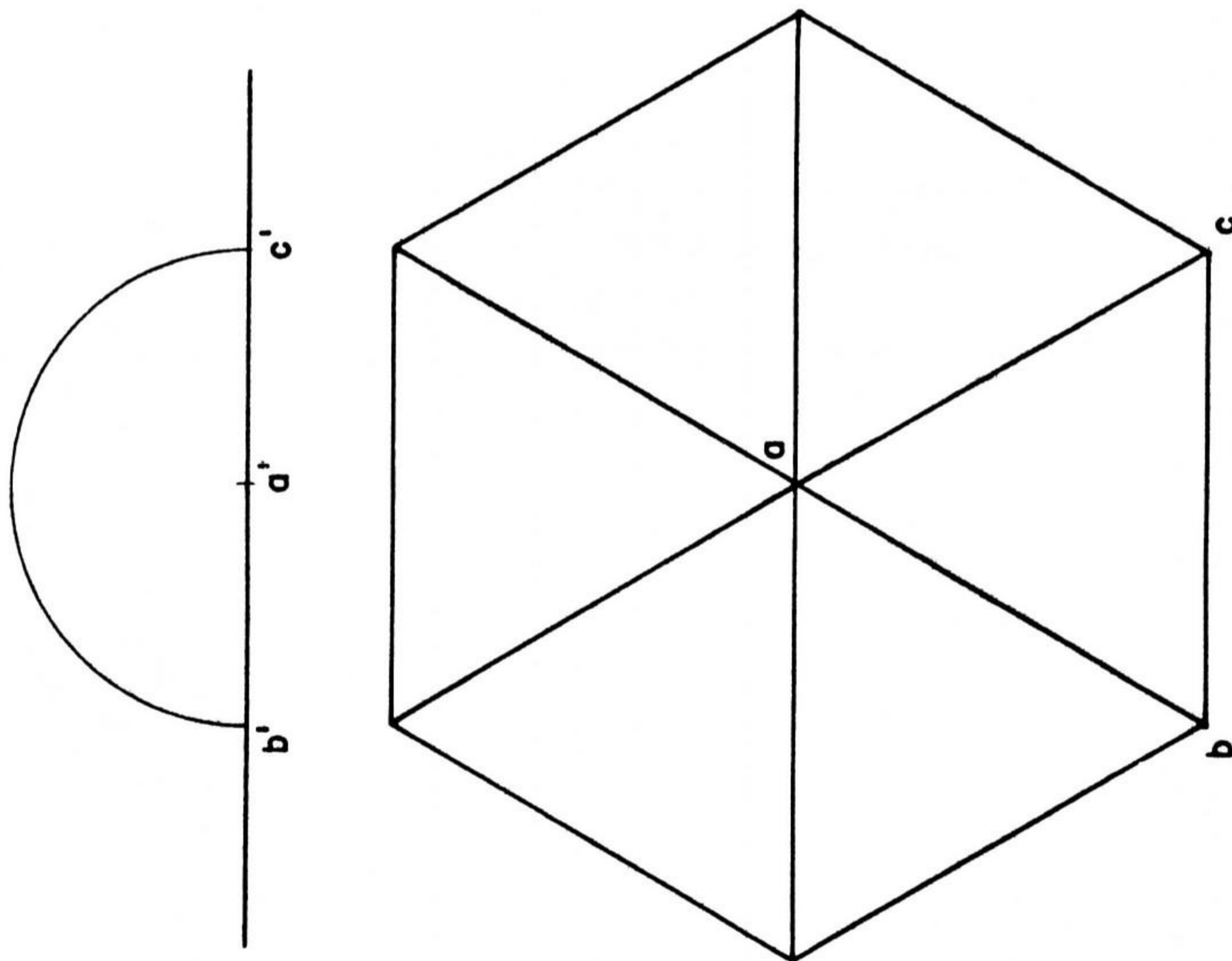

DPTO. DISEÑO BASICO

ISPJAE FACULTAD DE ARQUITECTURA

ASIGNATURA	TEMA		
DOC.	ALUM.	No.	GPO.
FECHA			EVAL.

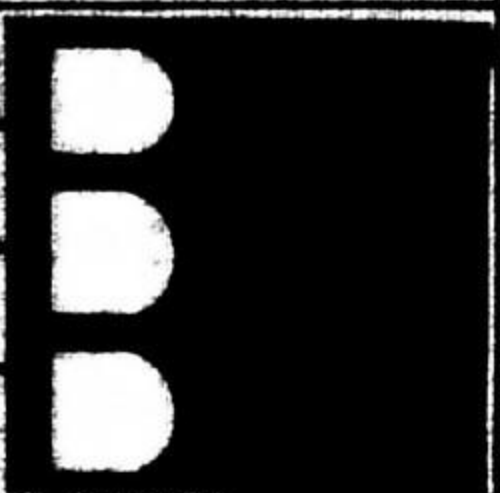

6.4 CILINDRO CIRCULAR : TERMINAR LA VISTA LATERAL Y DIBUJAR LA VISTA AUXILIAR Y EL DESARROLLO.

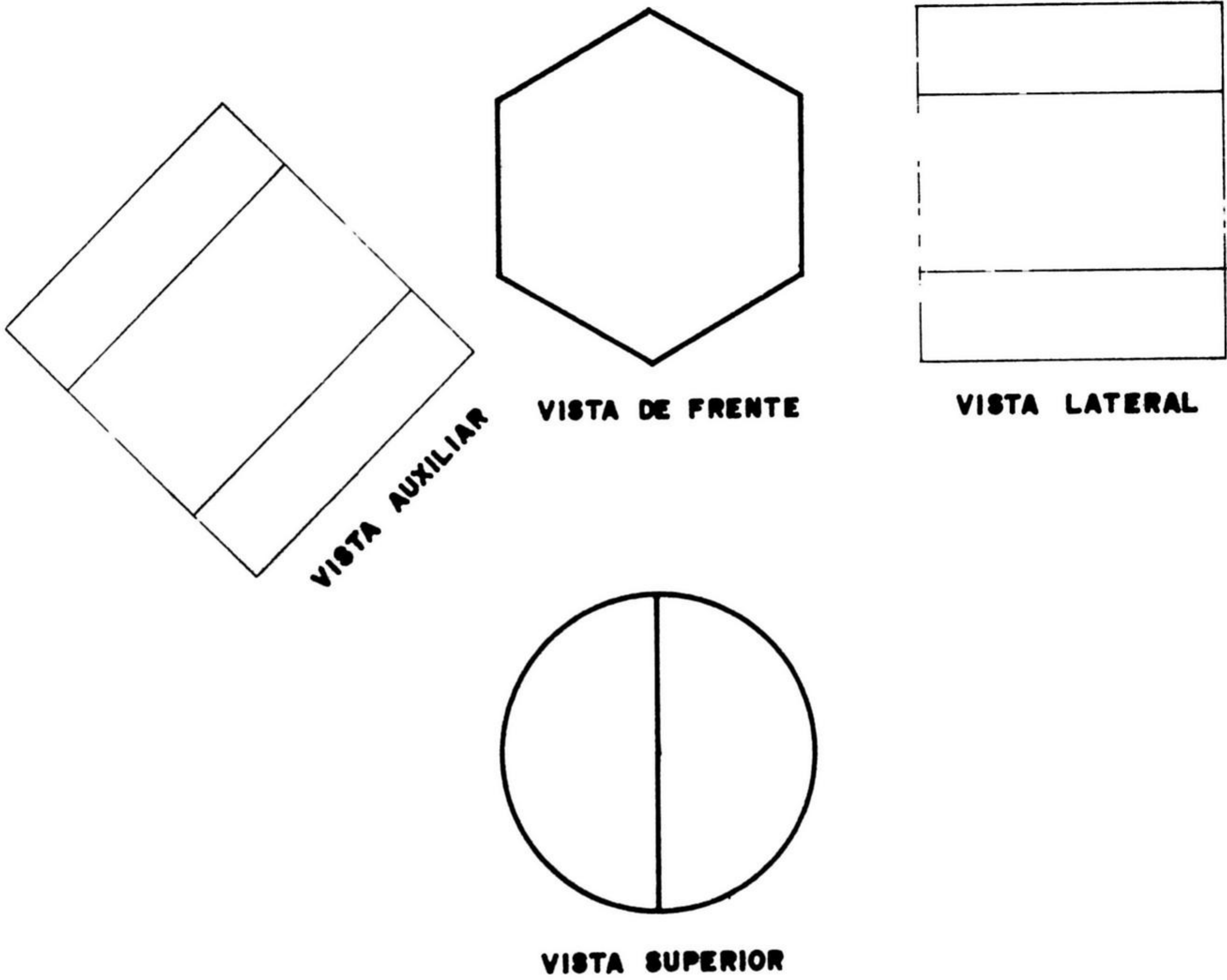

DPTO. DISEÑO BASICO		ISPJAE FACULTAD DE ARQUITECTURA	
SIGNATURA	TEMA		
DOC.	ALUM.	No.	GRUPO.
FECHA			EVAL.

6.4 CILINDRO CIRCULAR : DIBUJAR LA VISTA AUXILIAR Y EL DESARROLLO.

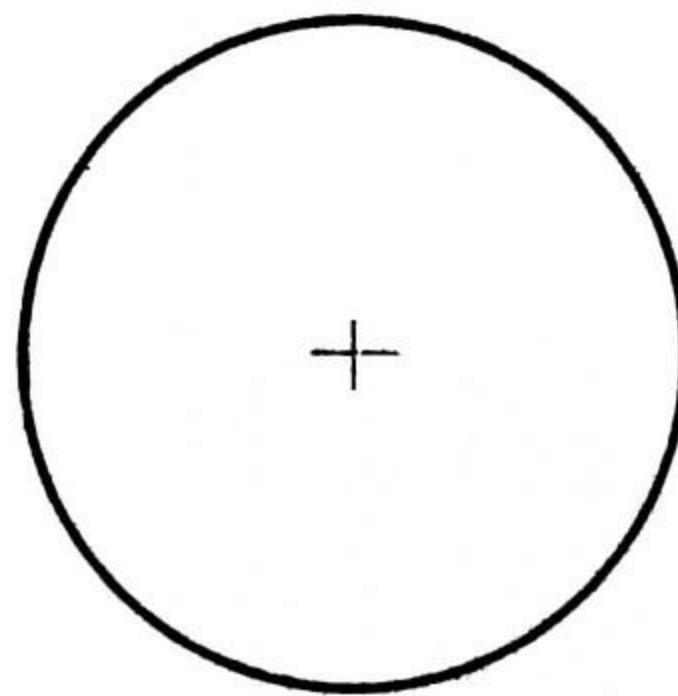
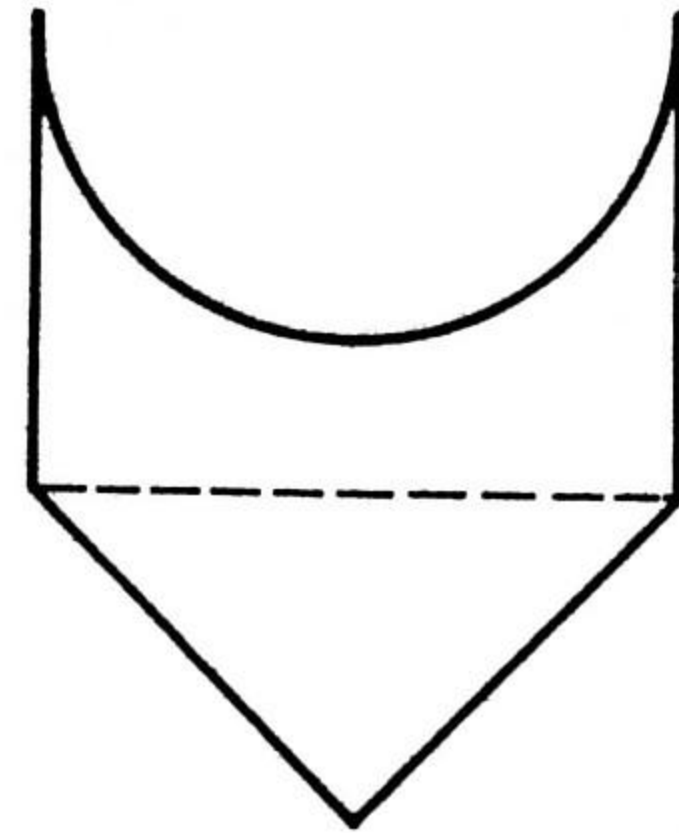
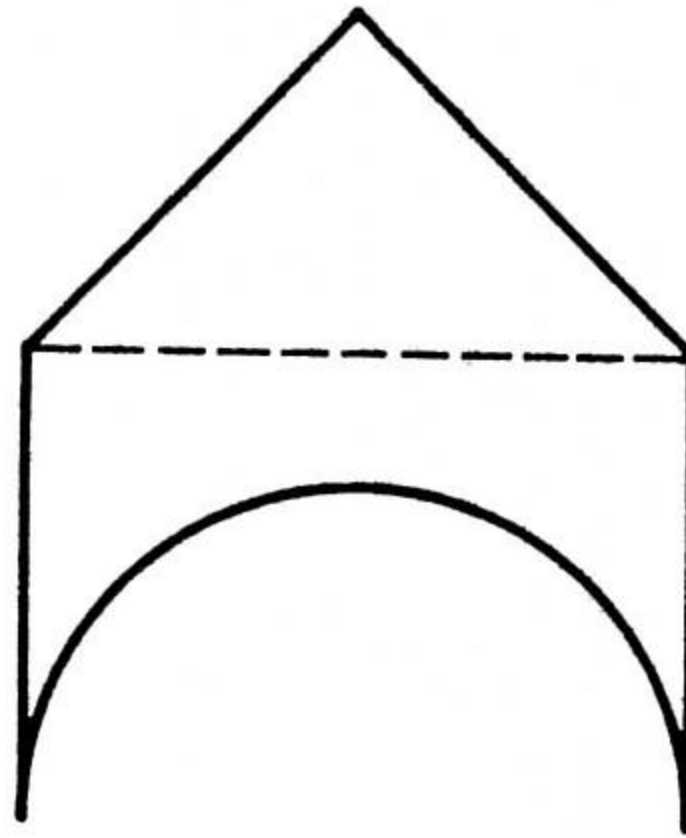
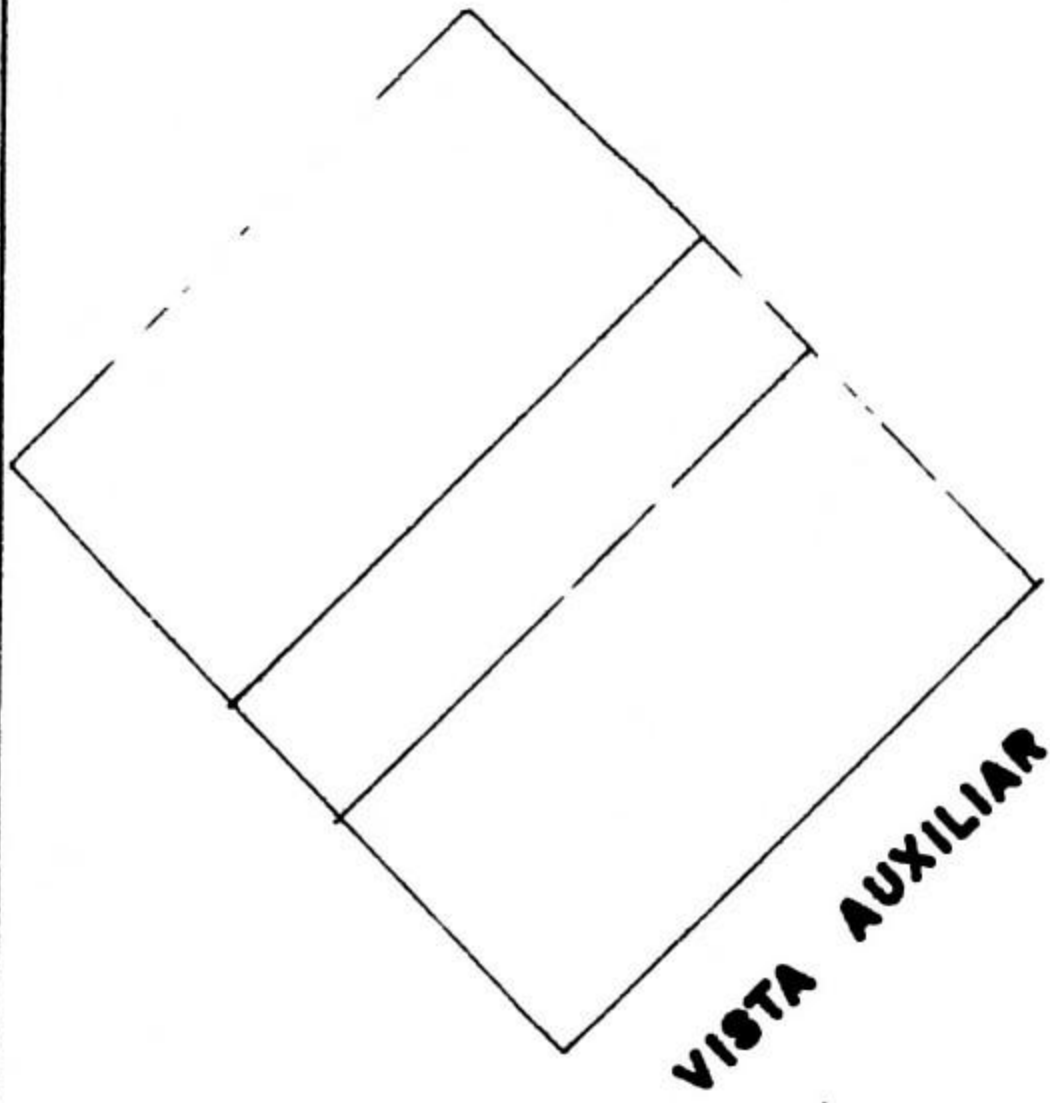

DPTO. DISEÑO BASICO		ISPJAE		D D D
		FACULTAD DE ARQUITECTURA		
ASIGNATURA	TEMA	No.	GPO.	
DOC.	ALUM.	EVAL.		
FECHA				

6.4 DETERMINAR LA INTERSECCION

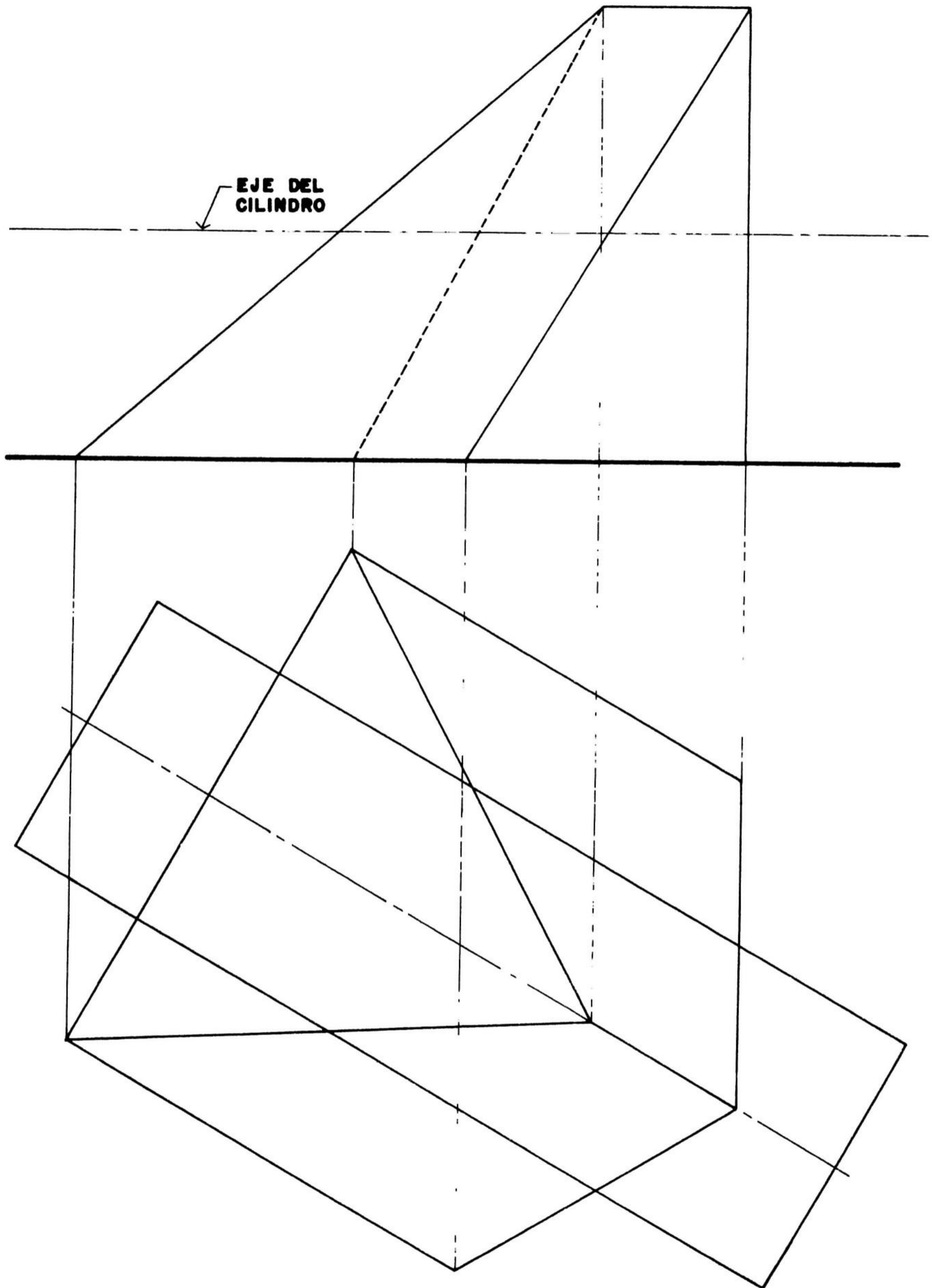

DPTO. DISEÑO BASICO		ISPJAE		FACULTAD DE ARQUITECTURA	
ASIGNATURA	TEMA				
DOC.	ALUM.	No.	GRPO.		
FECHA				EVAL.	

6.5 ESFERA.- HEMISFERIOS Y GENERATRICES DE CONTORNO.

A

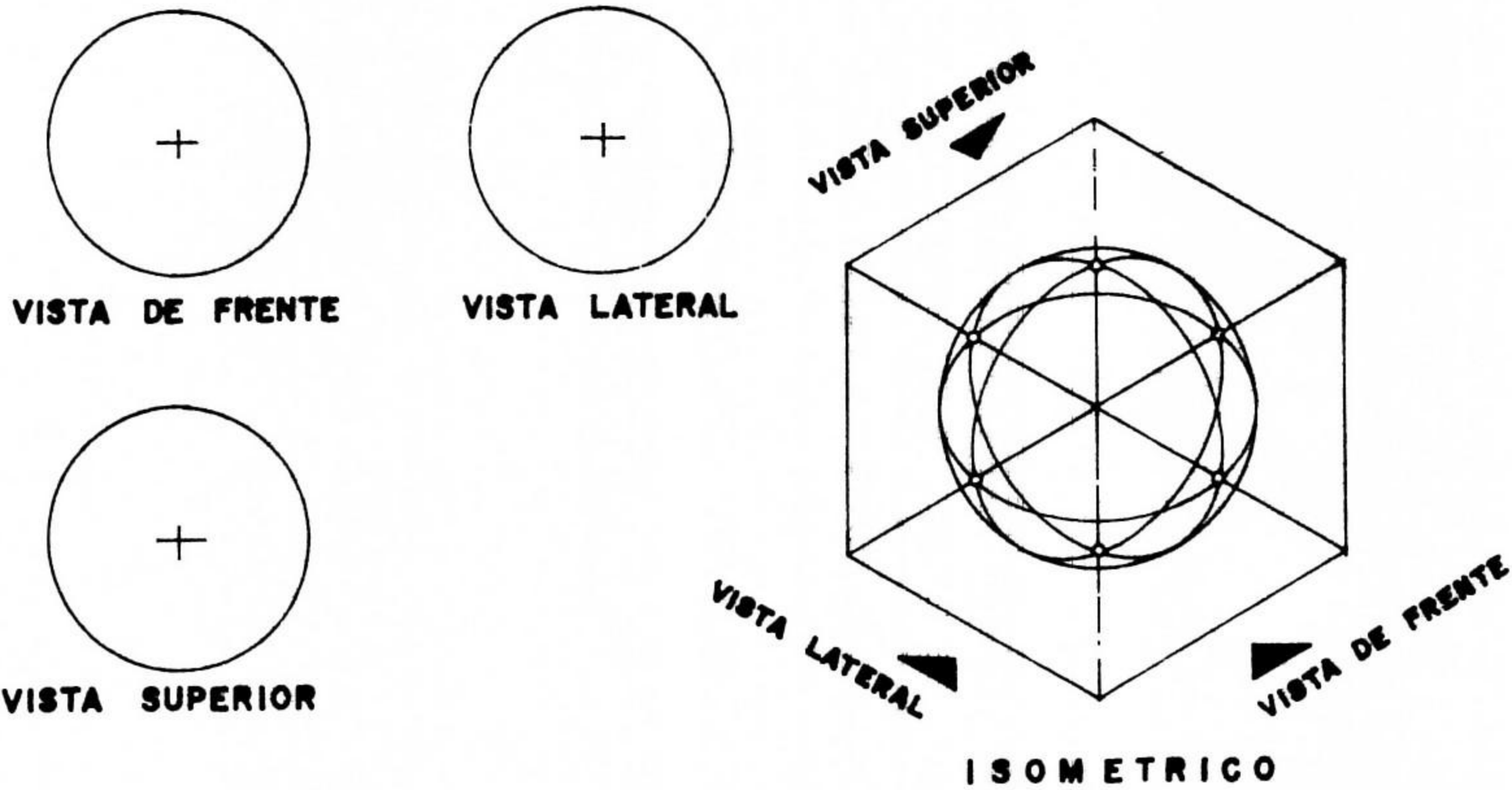

B

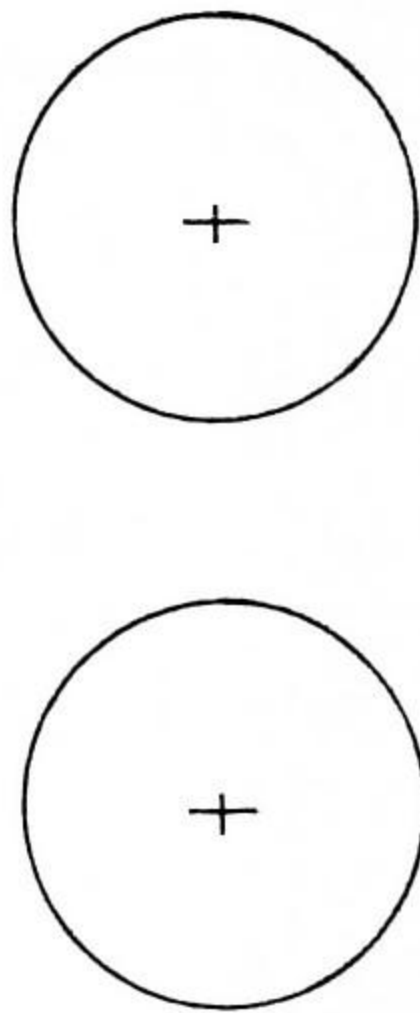

REGION SUPERIOR

C

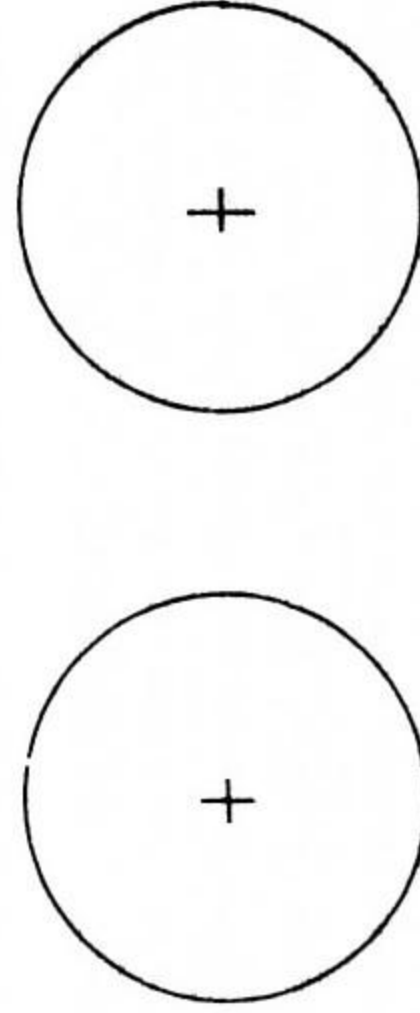

REGION ANTERIOR

D

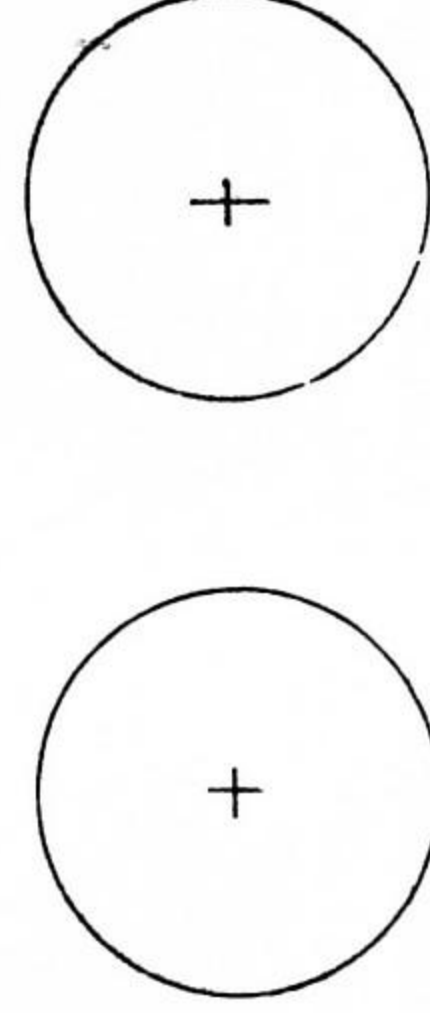

REGION IZQUIERDA

E

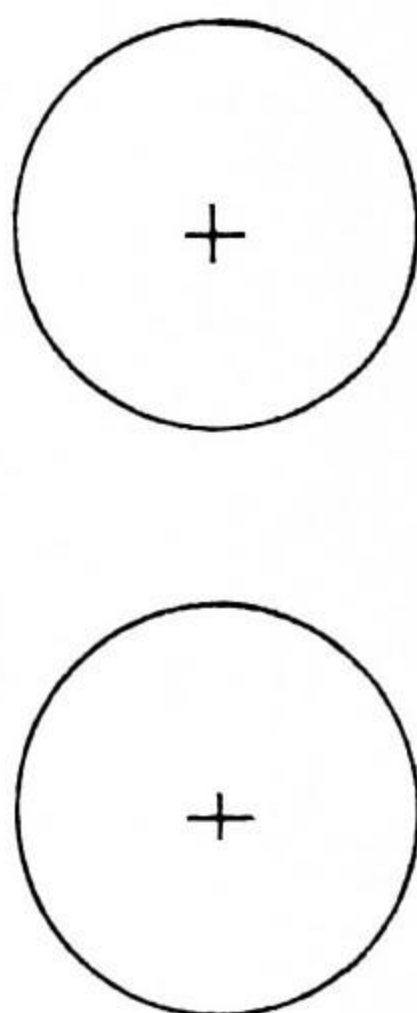

REGION POSTERIOR SUPERIOR IZQUIERDA

F

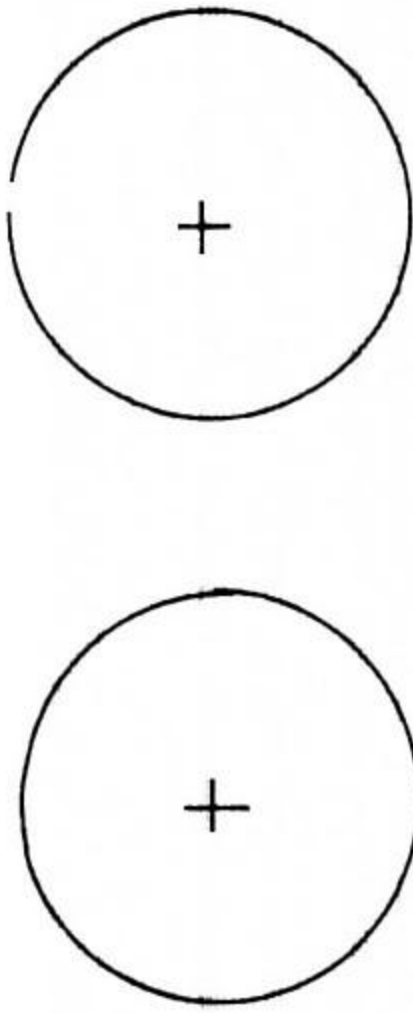

REGION ANTERIOR INFERIOR DERECHA

G

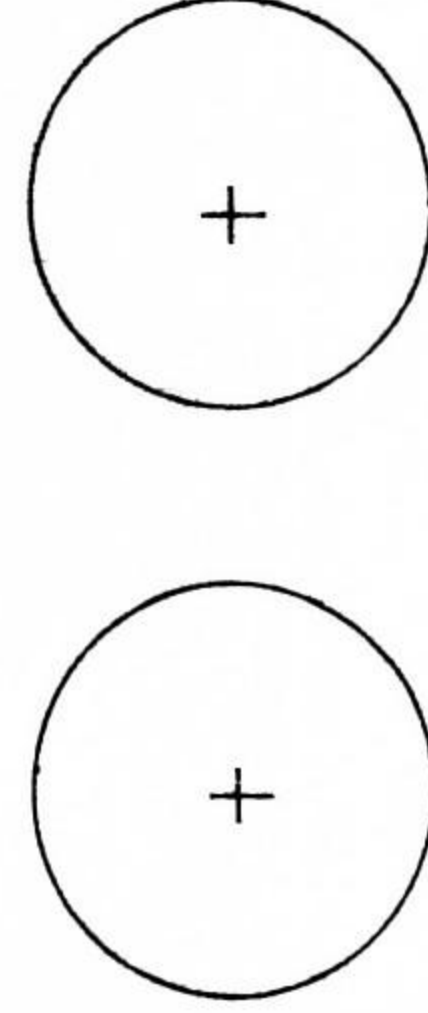

REGION POSTERIOR INFERIOR IZQUIERDA

DPTO. DISEÑO BASICO

ISPJAE FACULTAD DE ARQUITECTURA

ASIGNATURA	TEMA			D D D
DOC.	ALUM.	No.	GRU.	
FECHA			EVAL.	

6.5 CORTES ESFERA : DIBUJAR VISTA SUPERIOR Y VISTA LATERAL

A

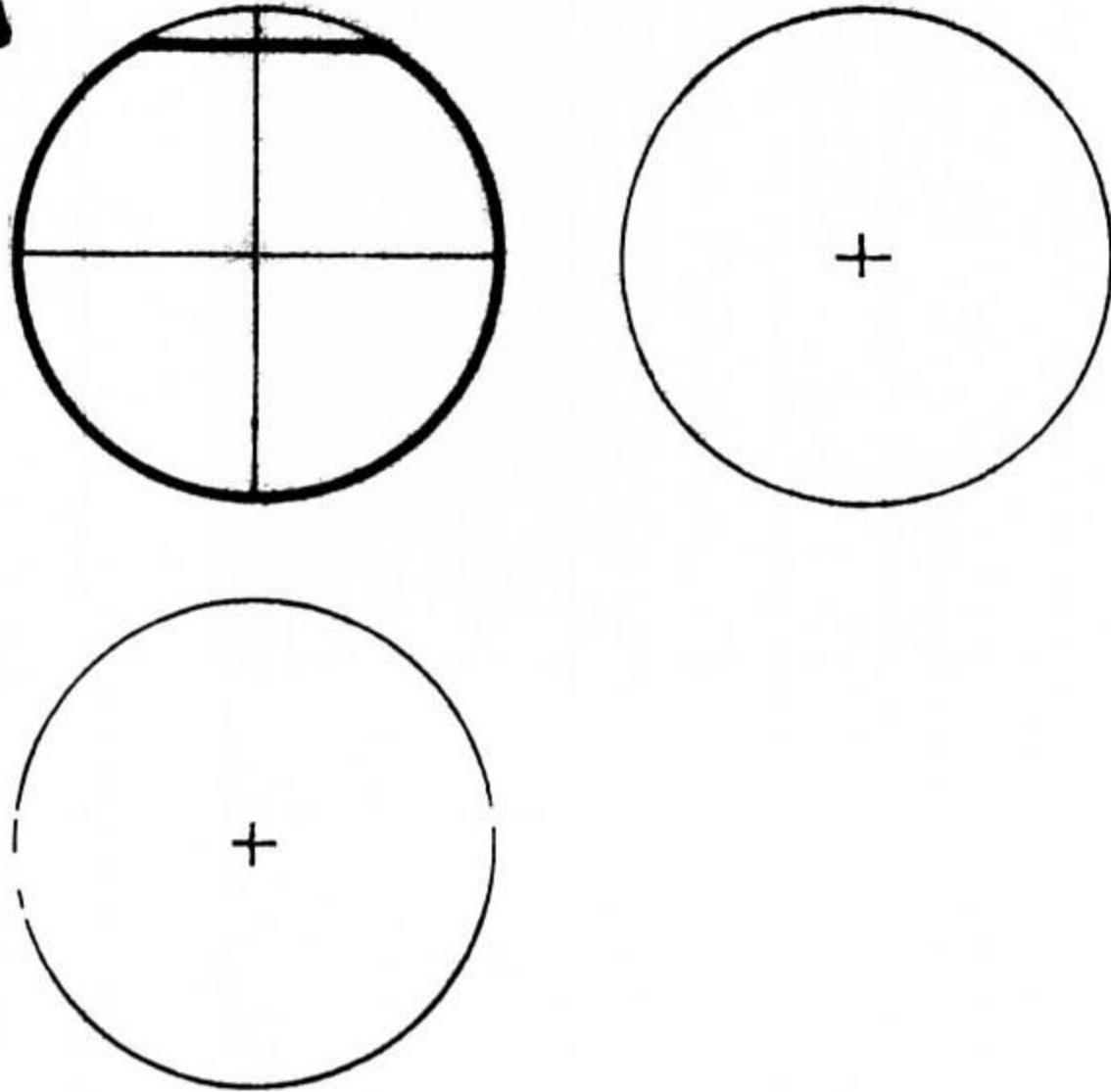

B

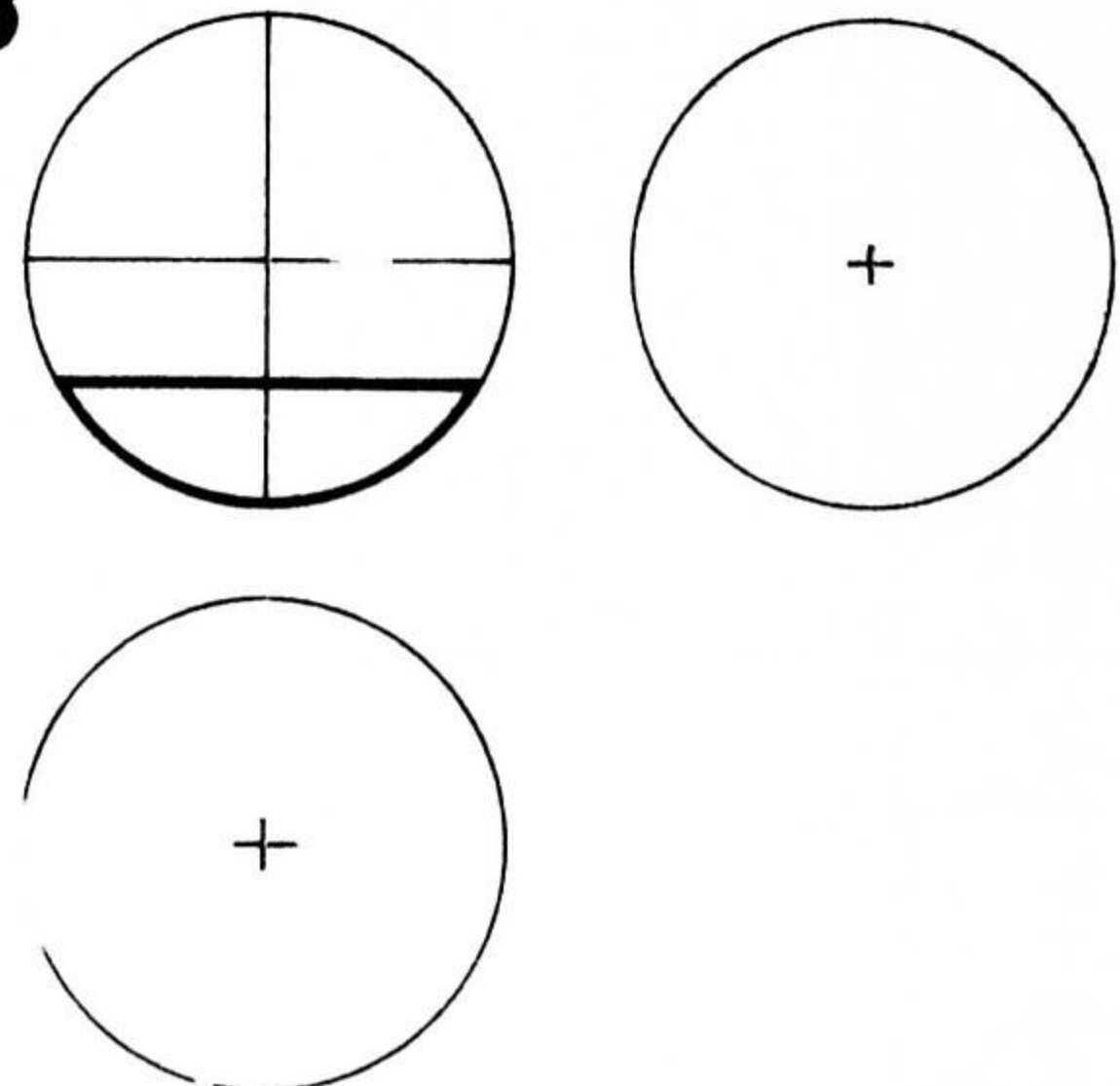

C

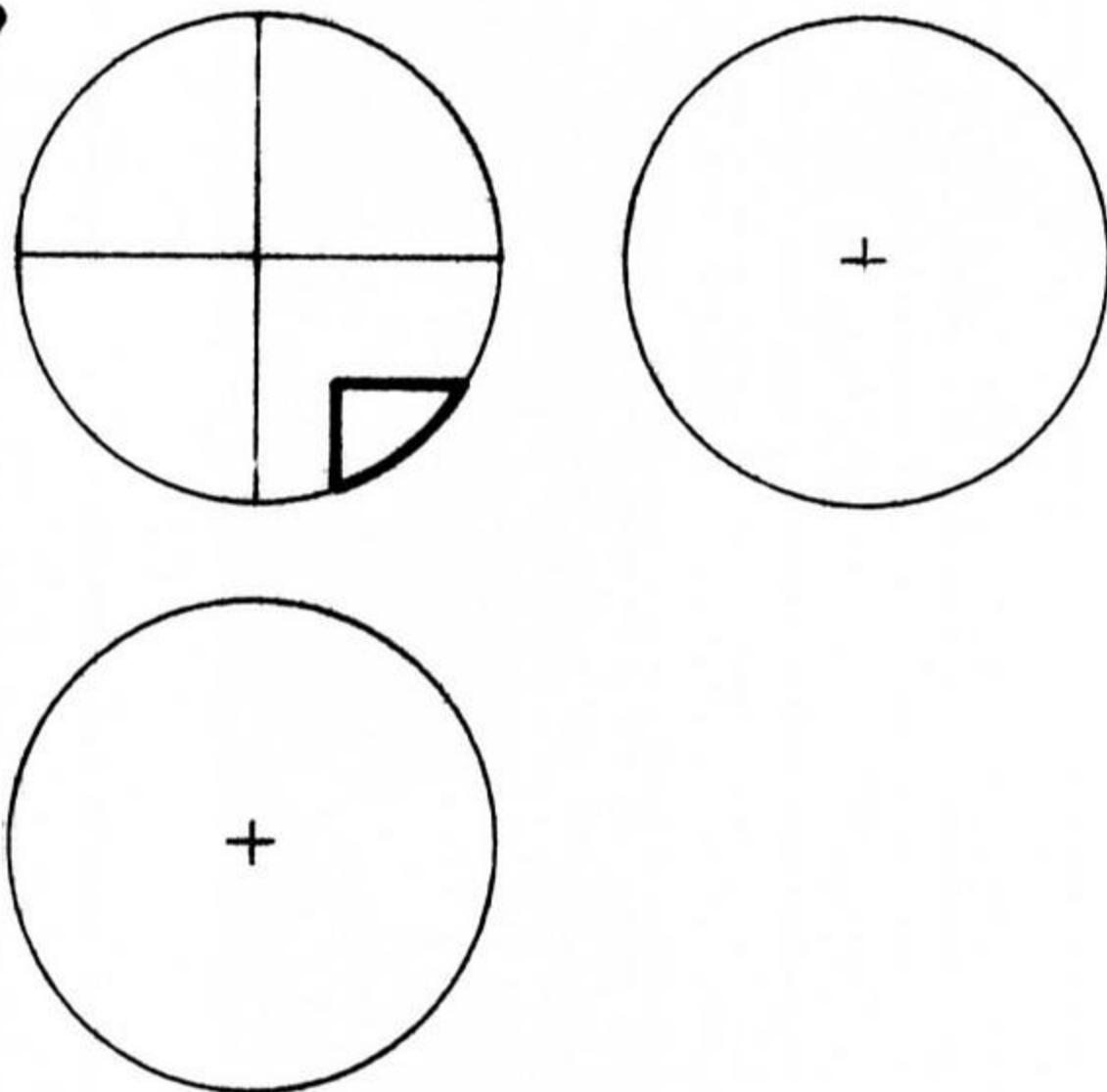

D

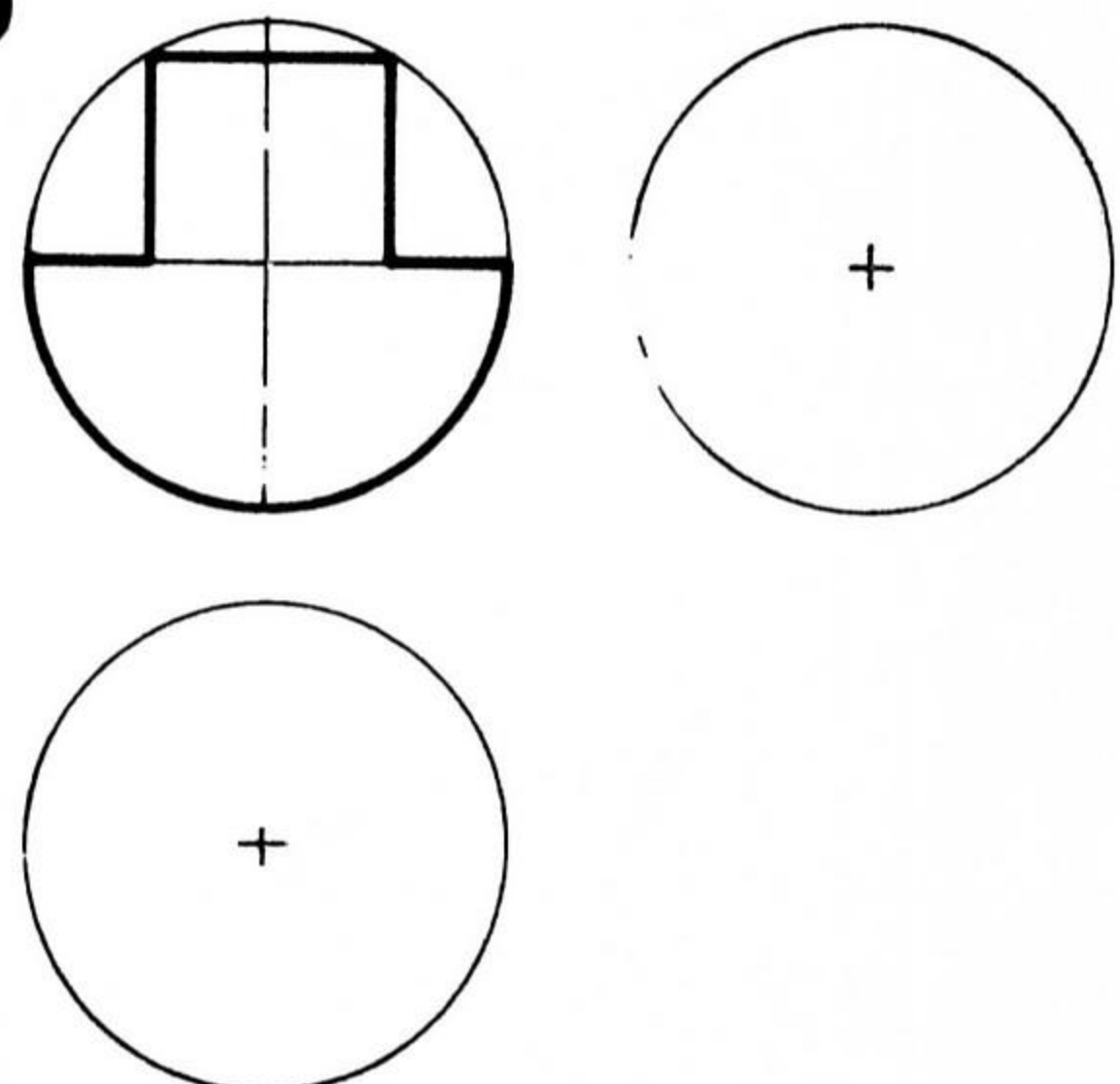

E

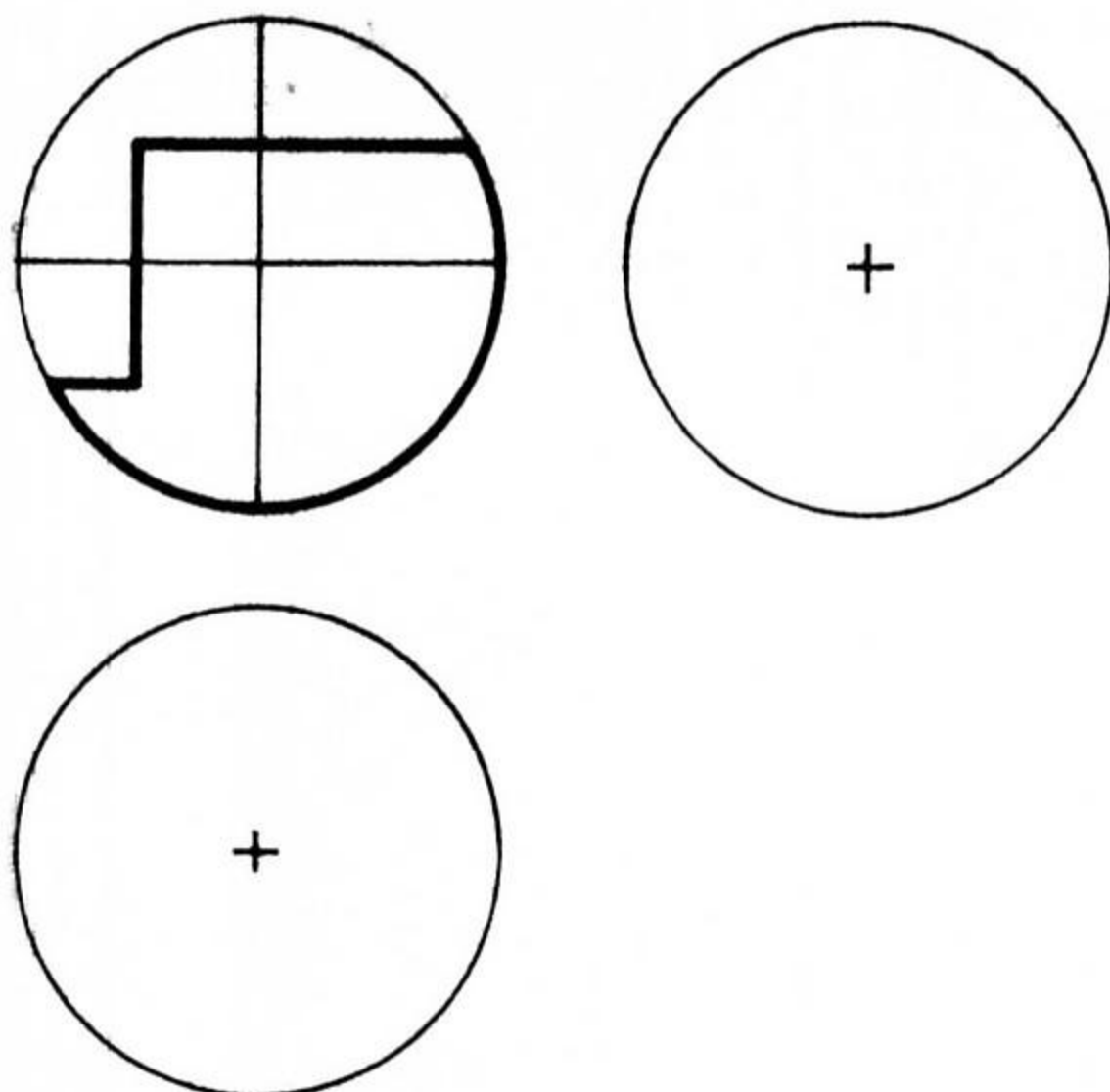

F

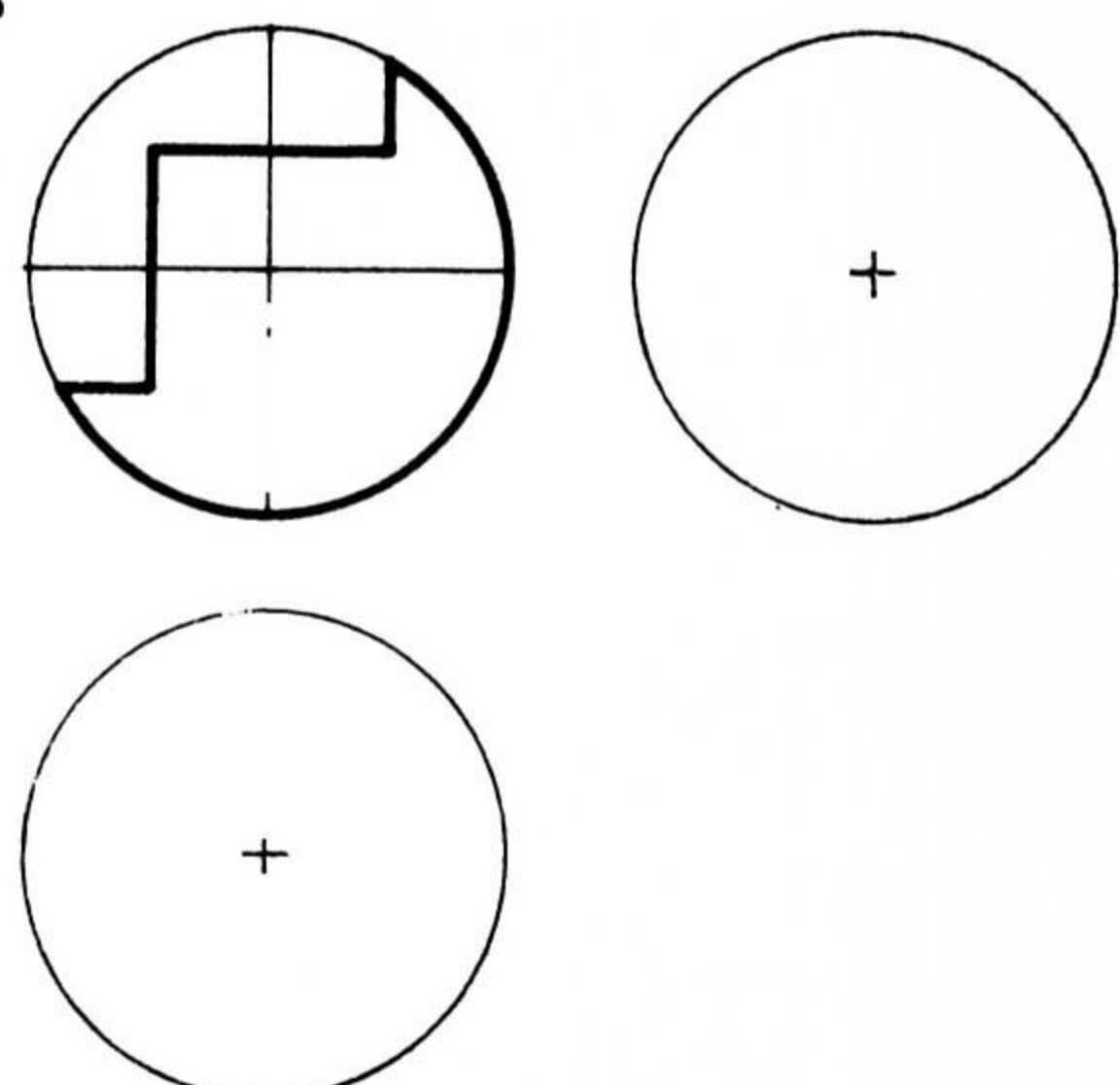

DPTO. DISEÑO BASICO

**ISPJAE
FACULTAD DE ARQUITECTURA**

ASIGNATURA

TEMA

DOC.

ALUM.

No.

GRUPO.

FECHA

EVAL.



6.5 ESFERA.- CONSTRUIR LAS CIRCUNFERENCIAS CUYOS DIAMETROS SON AB Y CD EN TODAS LAS VISTAS. CONSIDERAR LA ESFERA SOLIDA.

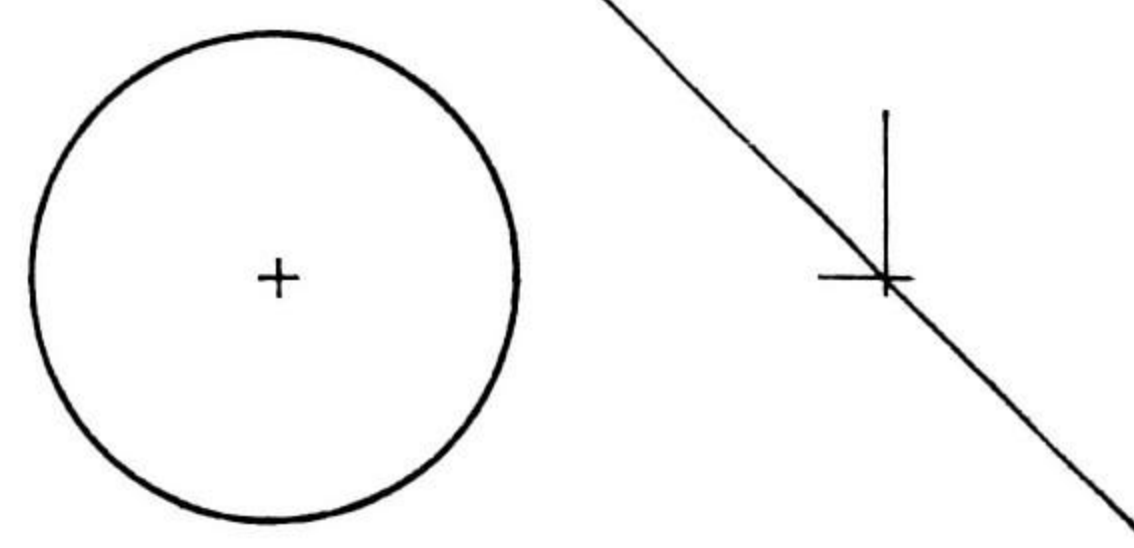
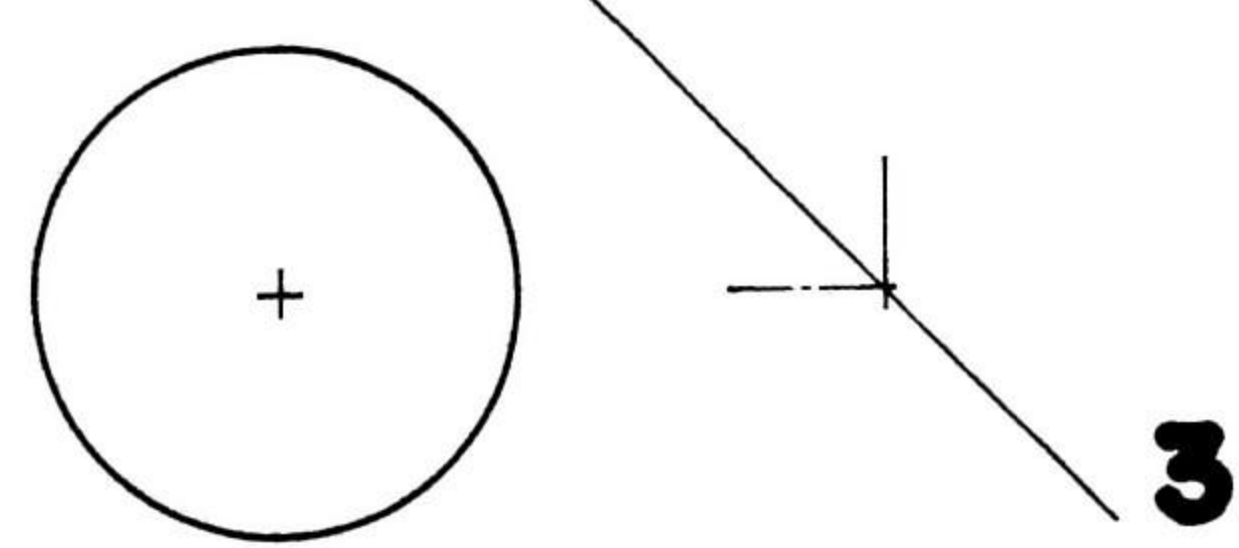
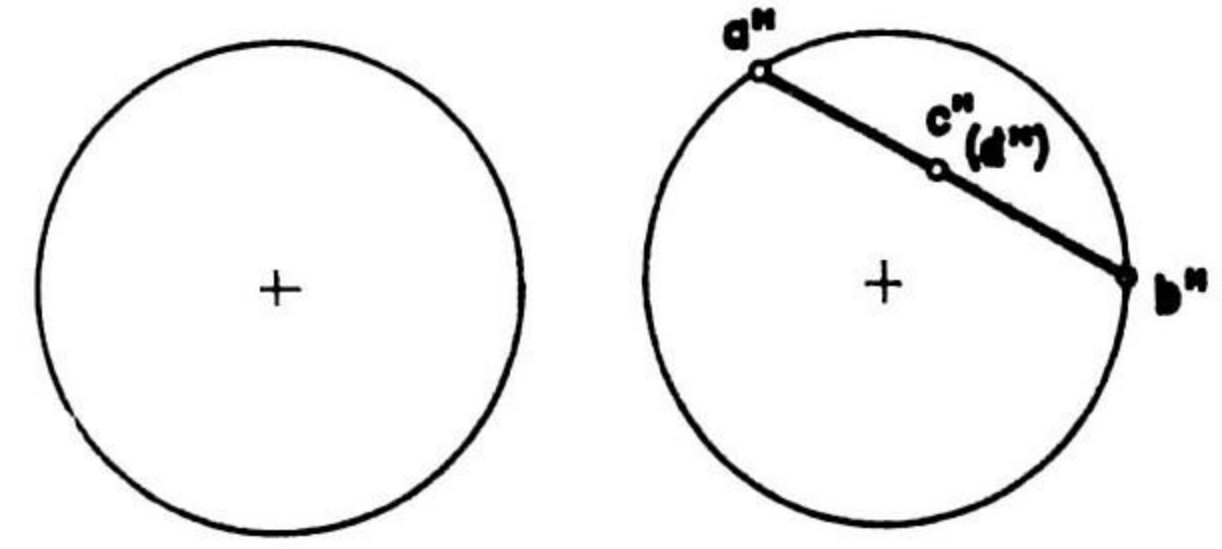
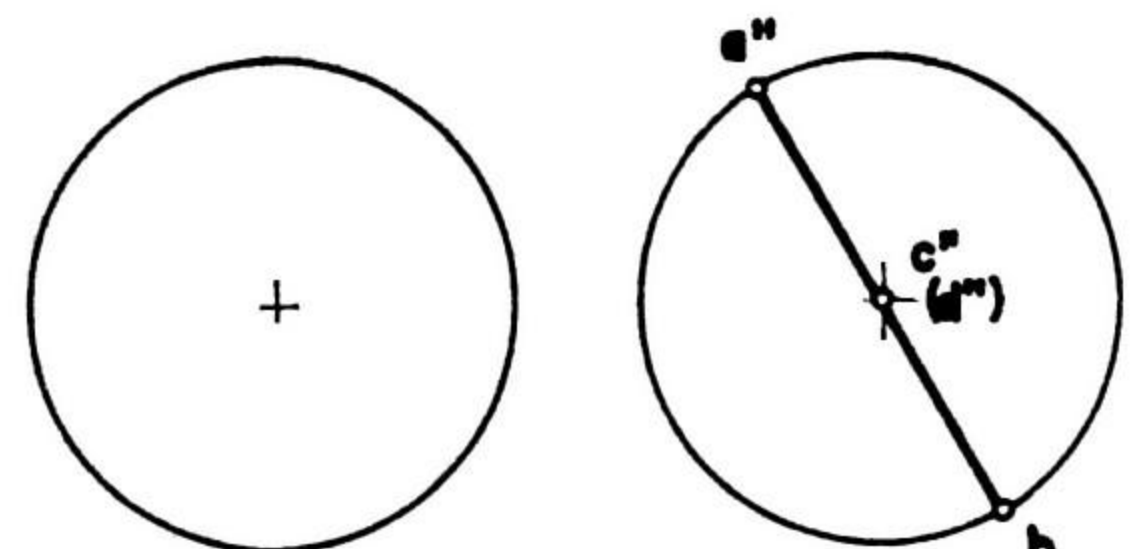
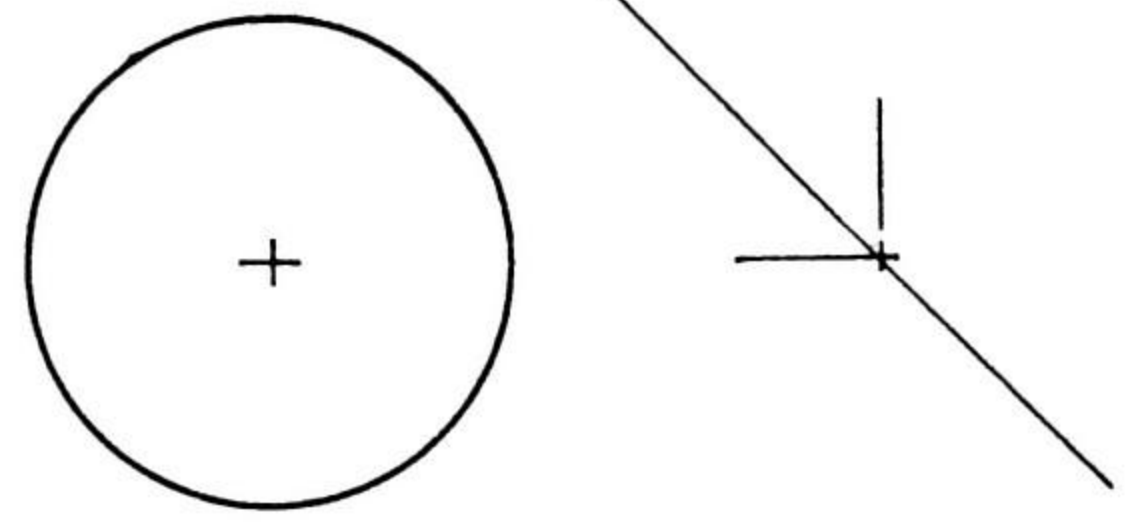
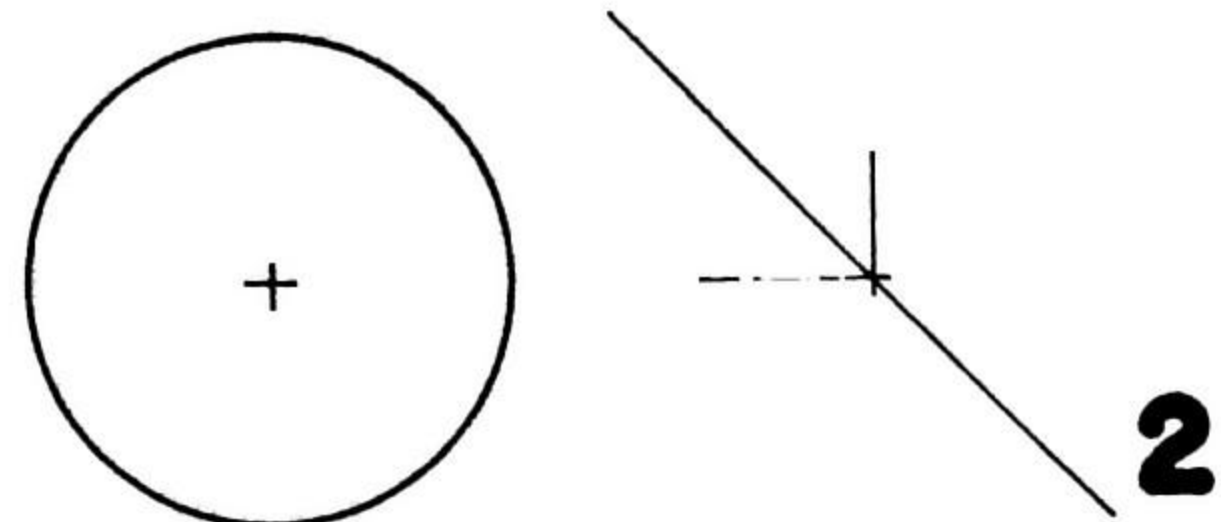
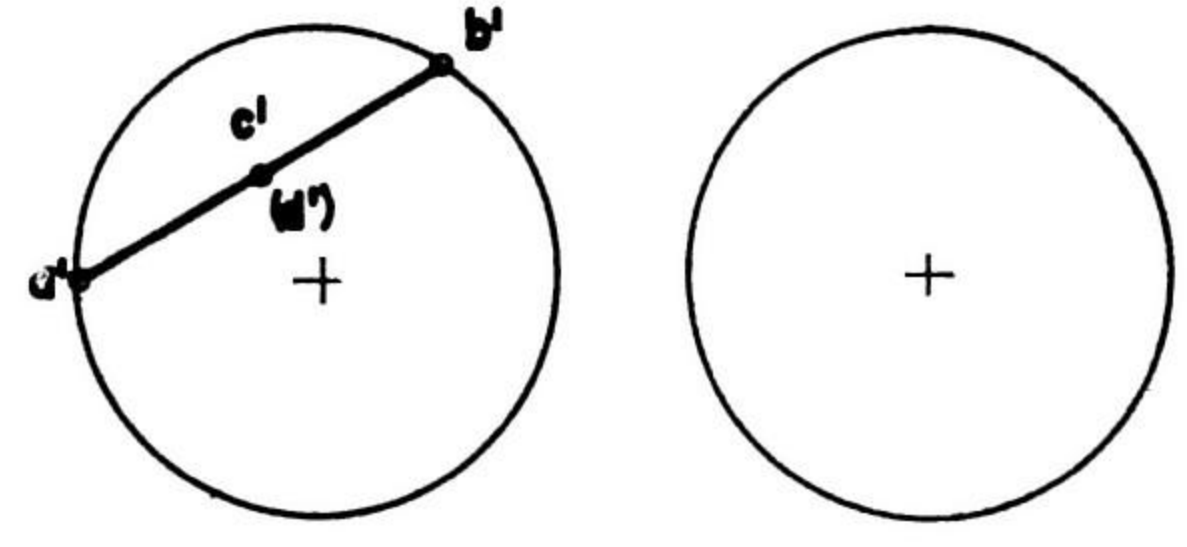
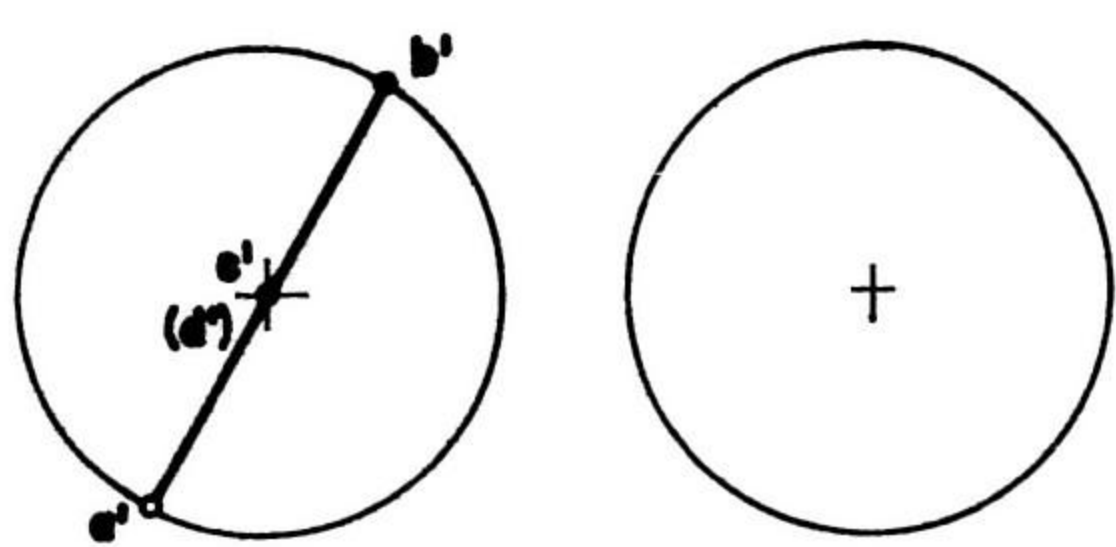
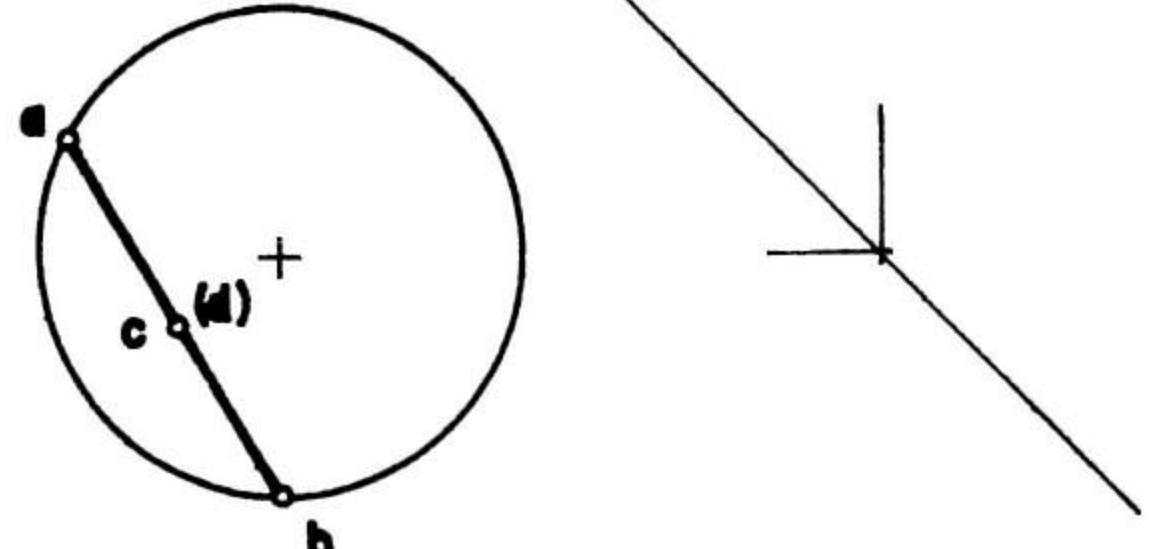
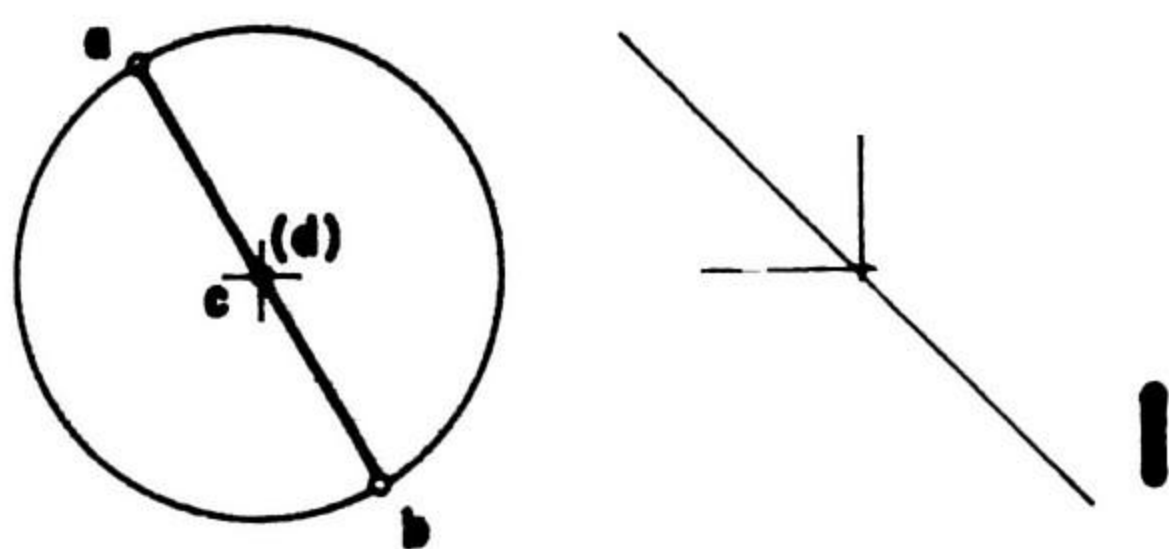
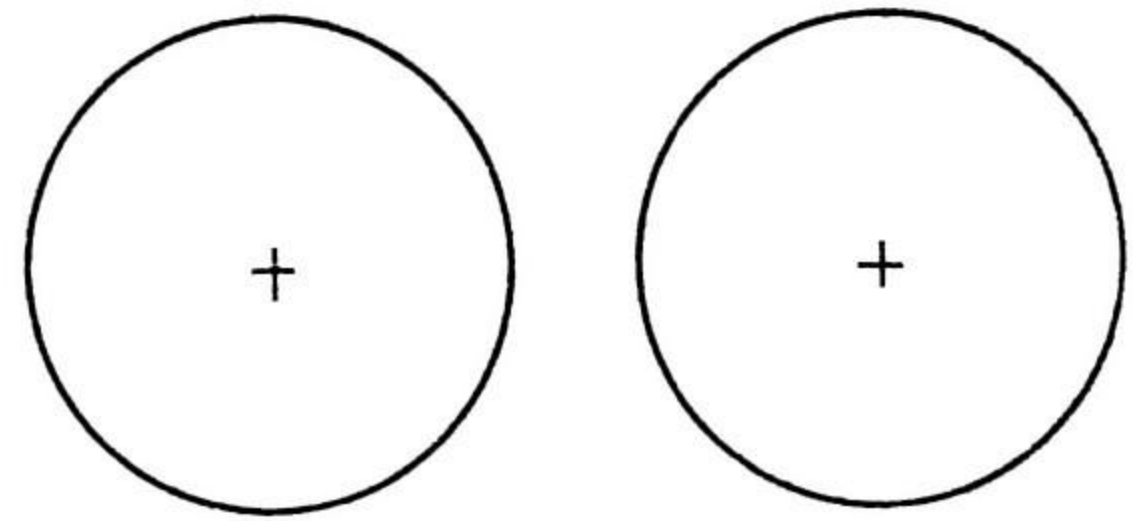
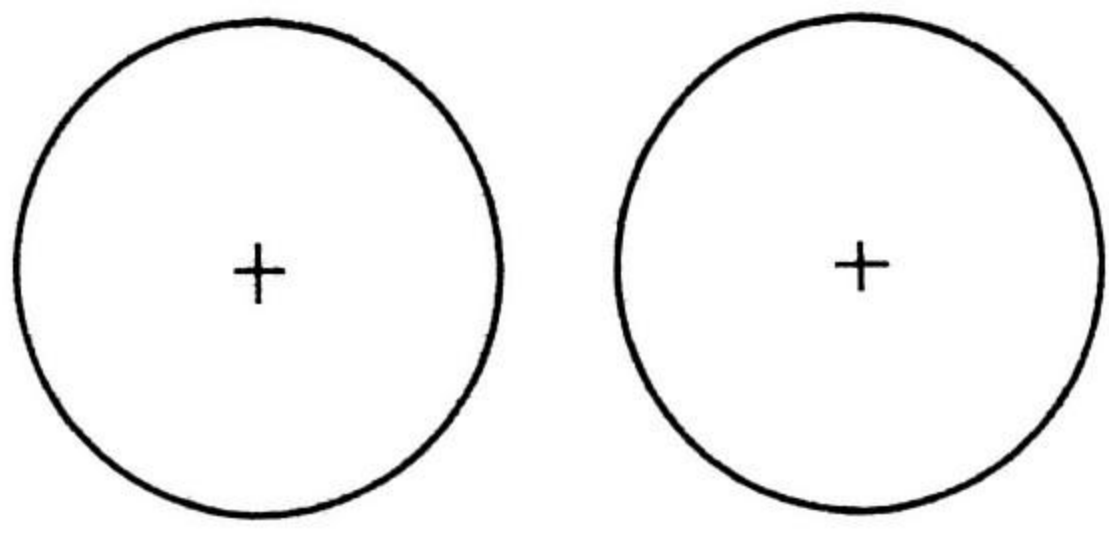

DPTO. DISEÑO BASICO

ISPJAE FACULTAD DE ARQUITECTURA

ASIGNATURA	TEMA		
DOC.	ALUM.	No.	GRUPO.
FECHA		EVAL.	

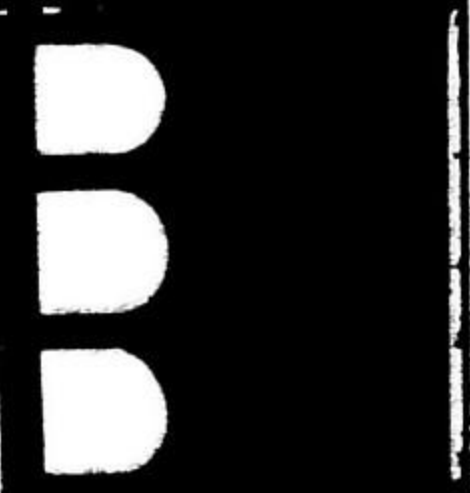

6.5 DETERMINAR EN VISTA DE FRENTE Y VISTA SUPERIOR, LOS CORTES DADOS A LA ESFERA EN LA VISTA LATERAL.

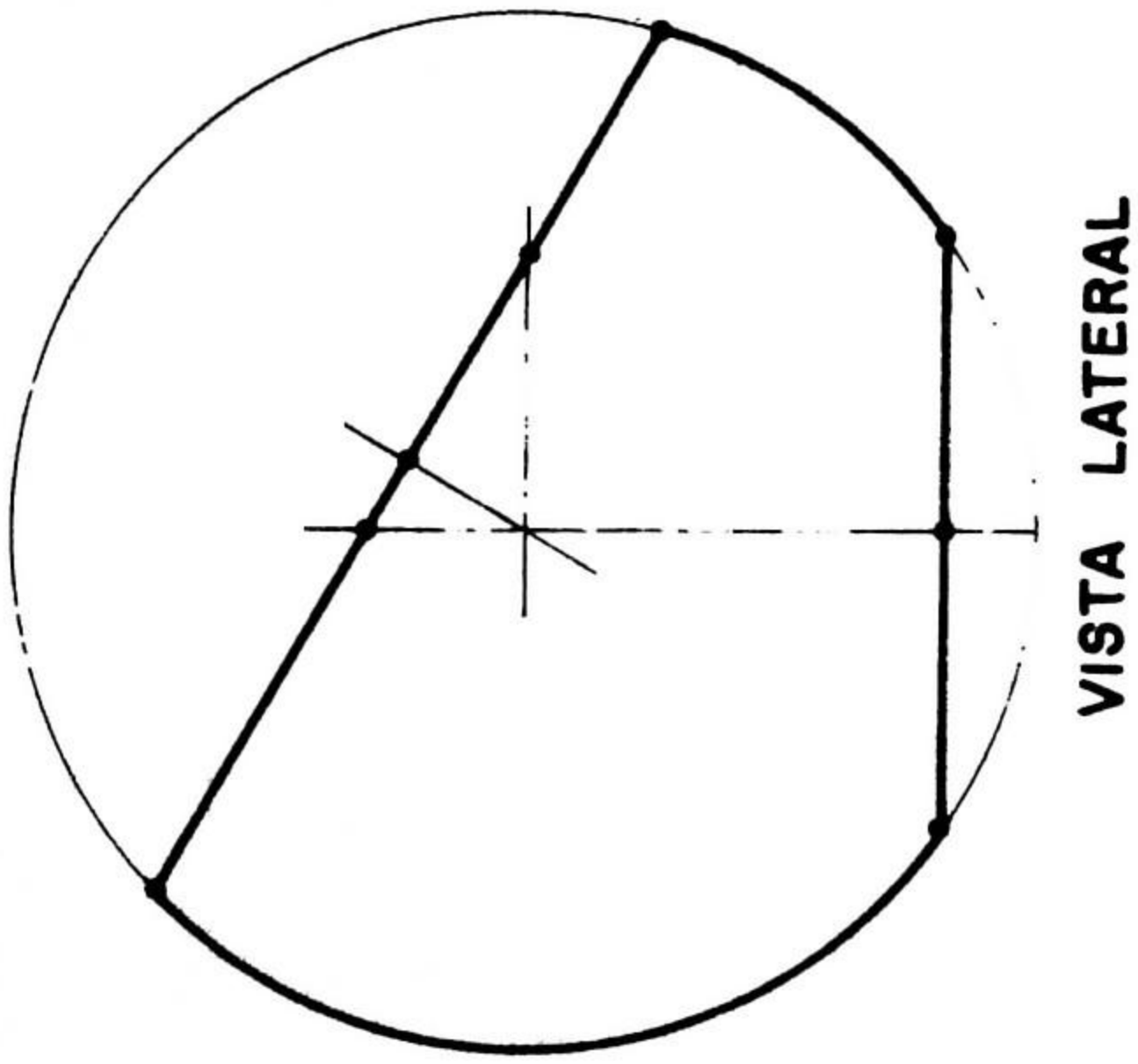

VISTA LATERAL

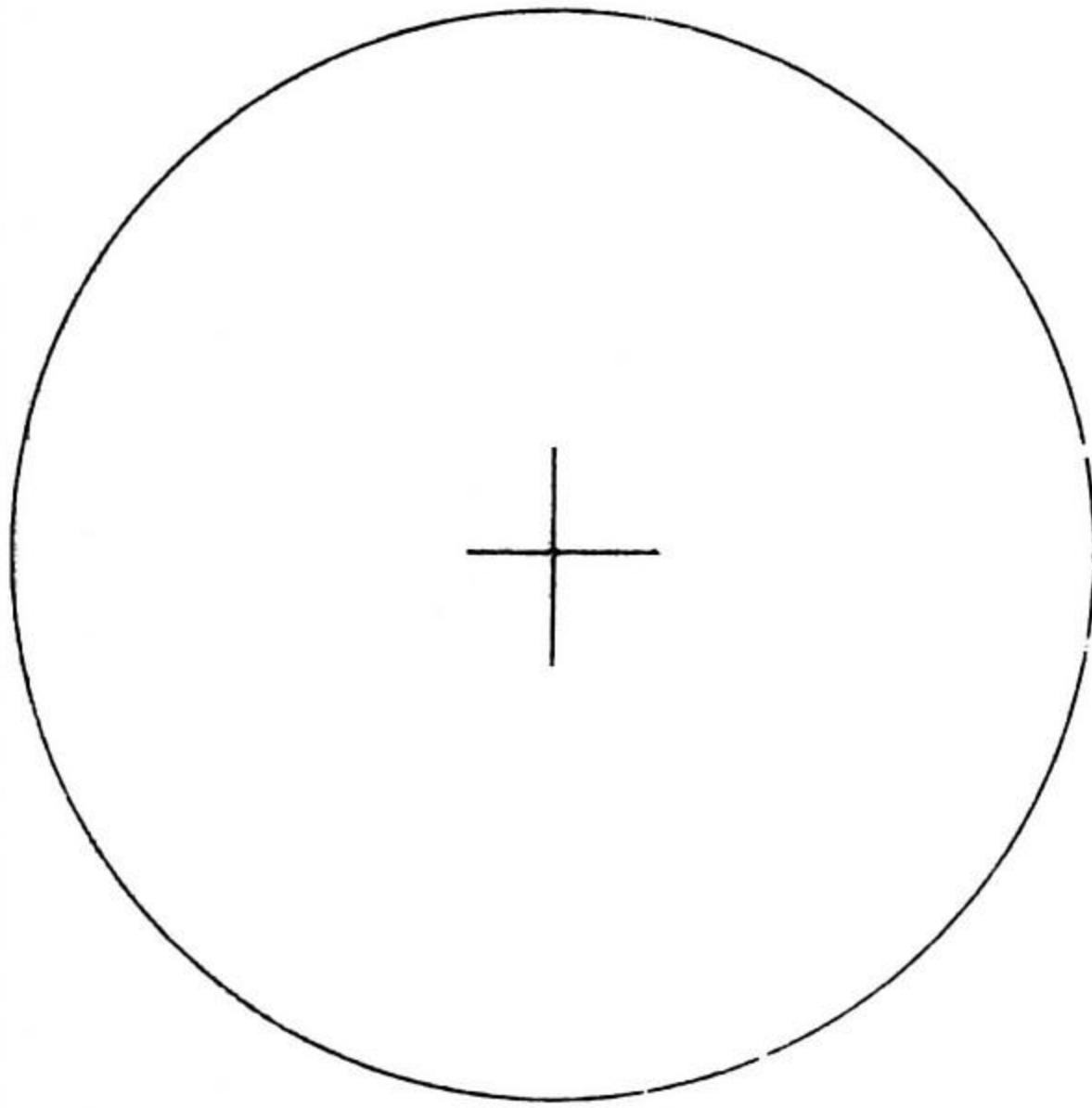

VISTA DE FRENTE

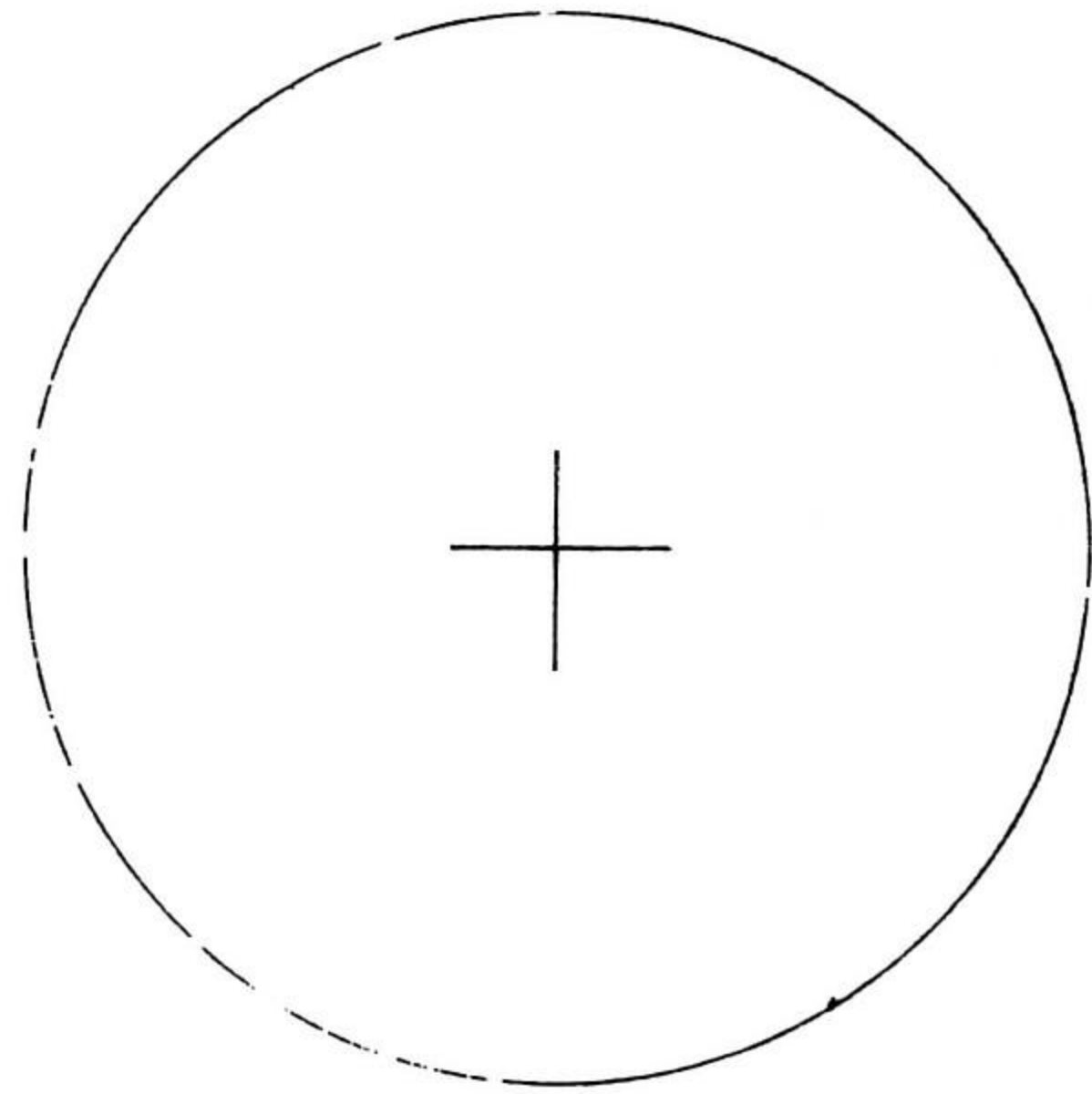

VISTA SUPERIOR

DPTO. DISEÑO BASICO		ISPJAE		D D D
		FACULTAD DE ARQUITECTURA		
ASIGNATURA	TEMA			
DOC.	ALUM.	No.	GRPO.	
FECHA			EVAL.	

6.6 DETERMINAR LAS INTERSECCIONES CORRESPONDIENTES

A

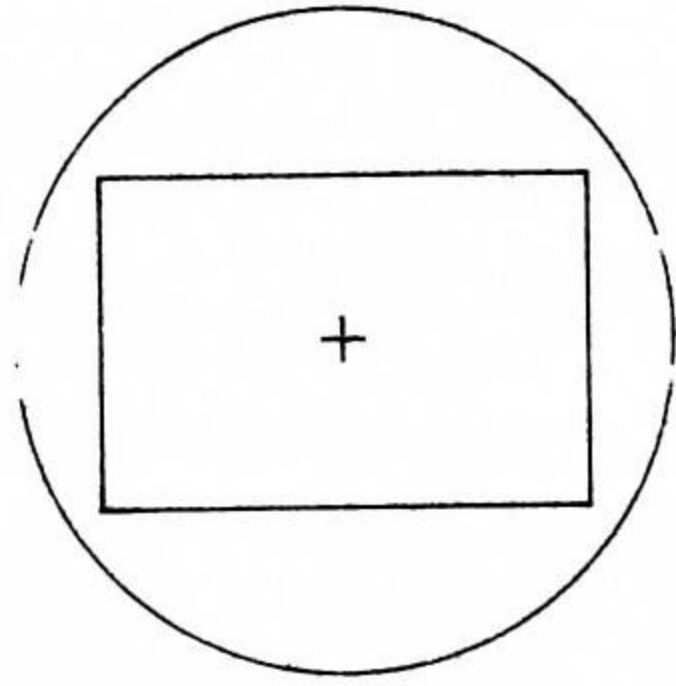
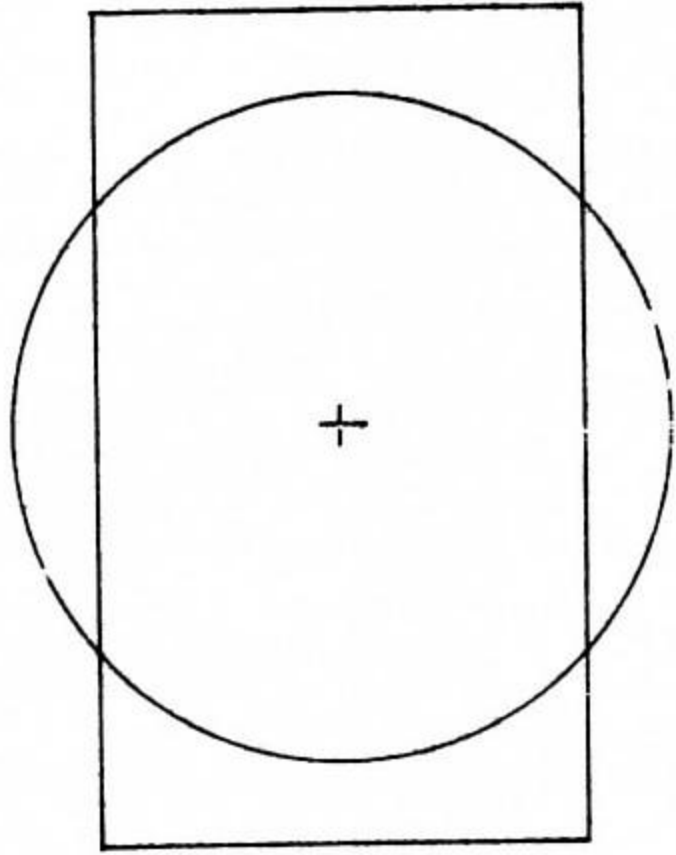

ESFERA Y PRISMA RECTO

B

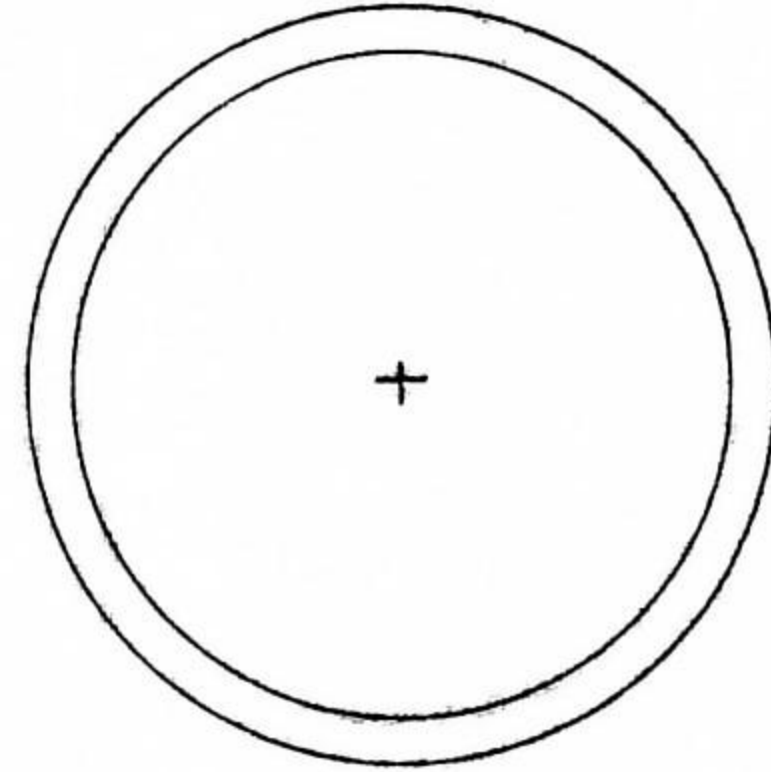
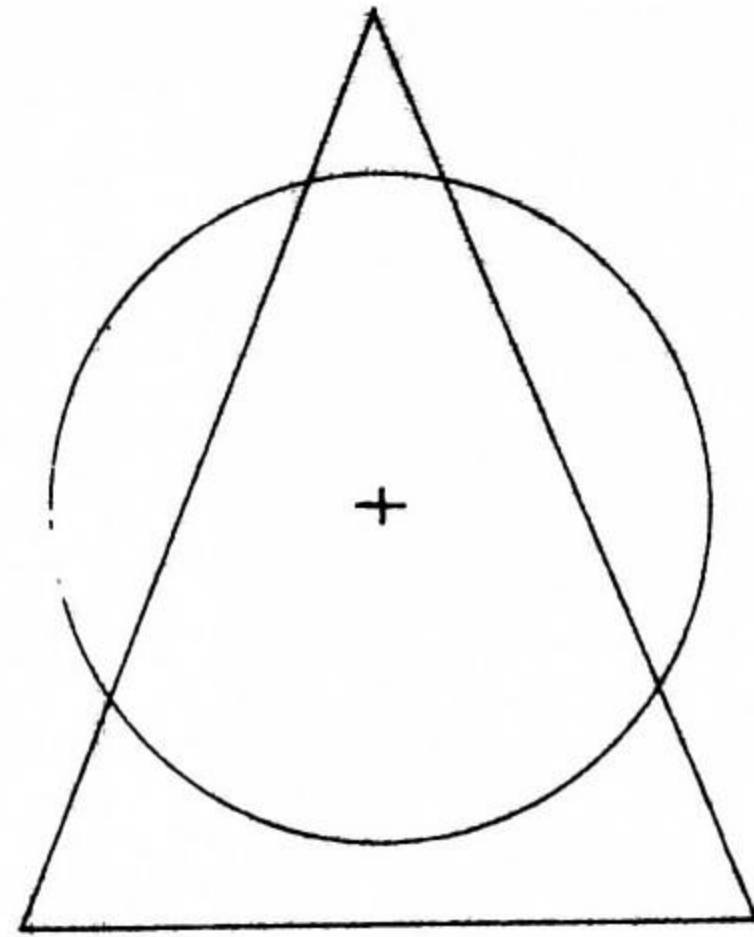

ESFERA Y CONO

C

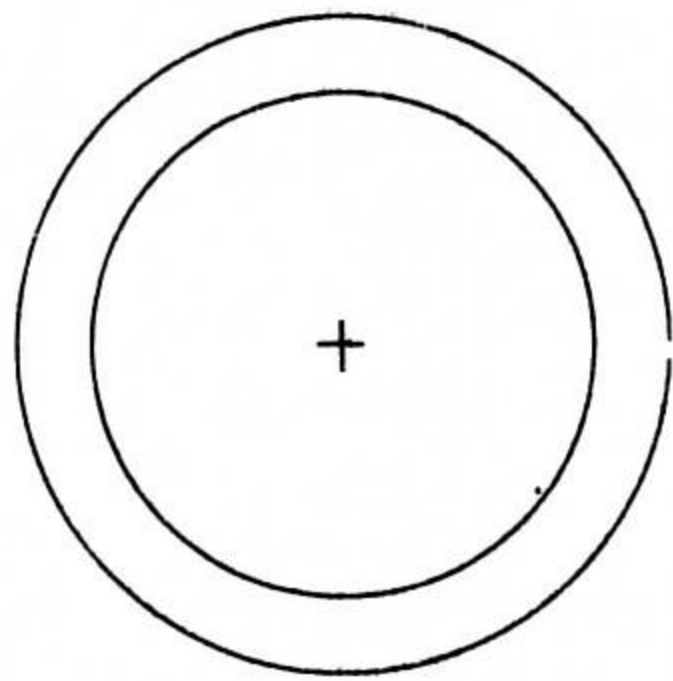
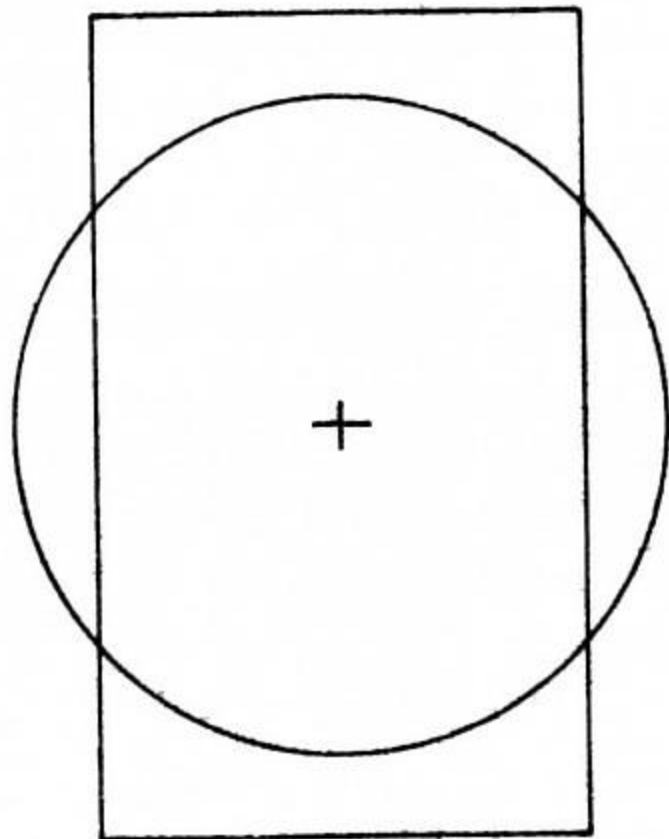

ESFERA Y CILINDRO

D

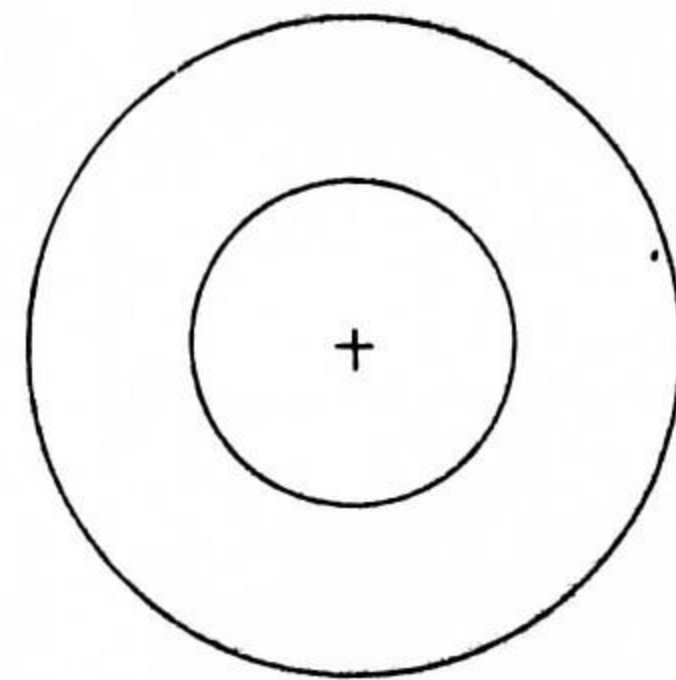
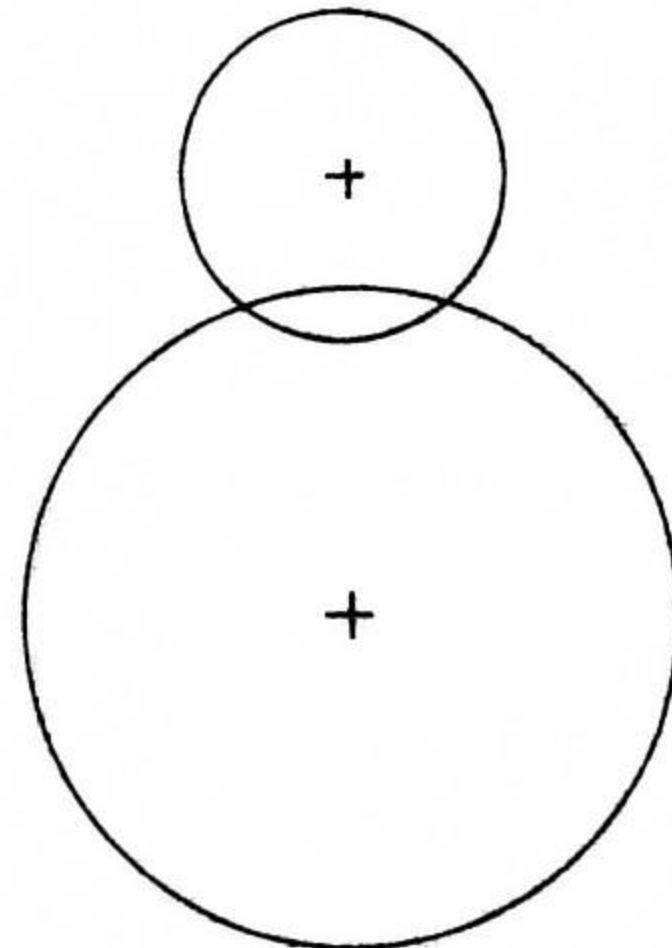

ESFERAS

DPTO. DISEÑO BASICO

ISPJAE FACULTAD DE ARQUITECTURA

ASIGNATURA

TEMA

DOC.

ALUM.

№.

OPD.

FECHA

EVAL.

6.6 DIBUJAR LAS VISTAS QUE FALTAN

A

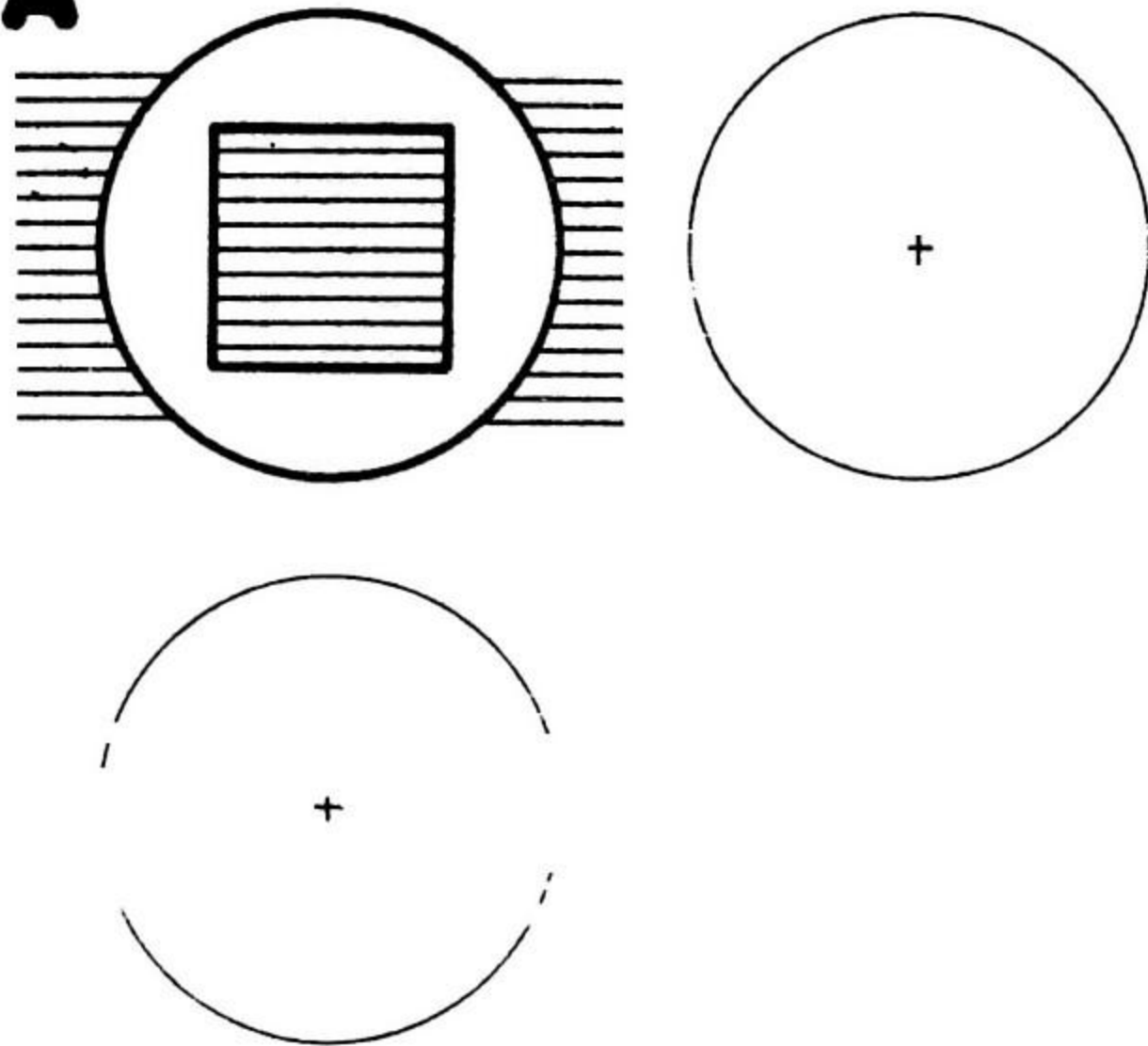

B

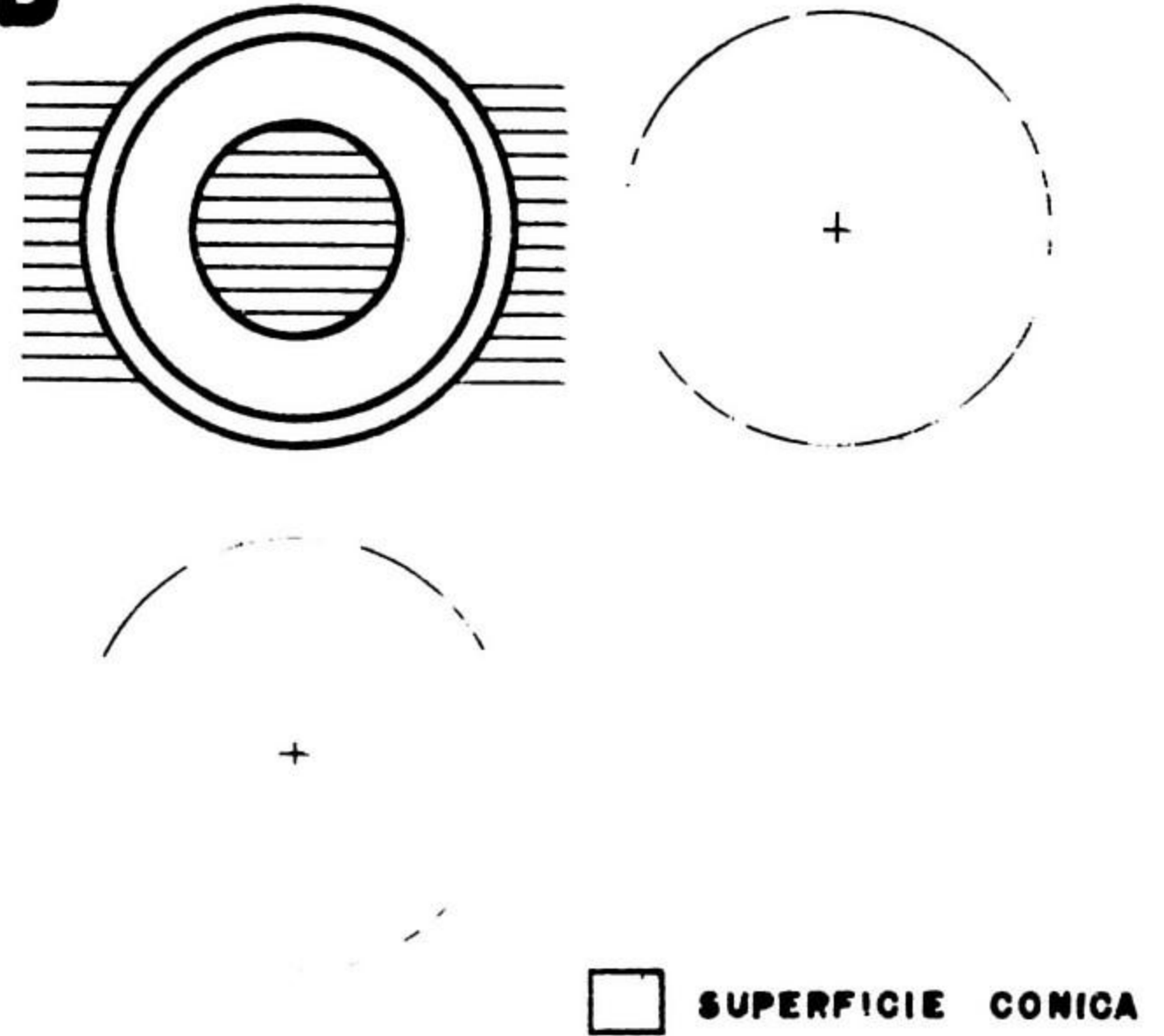

C

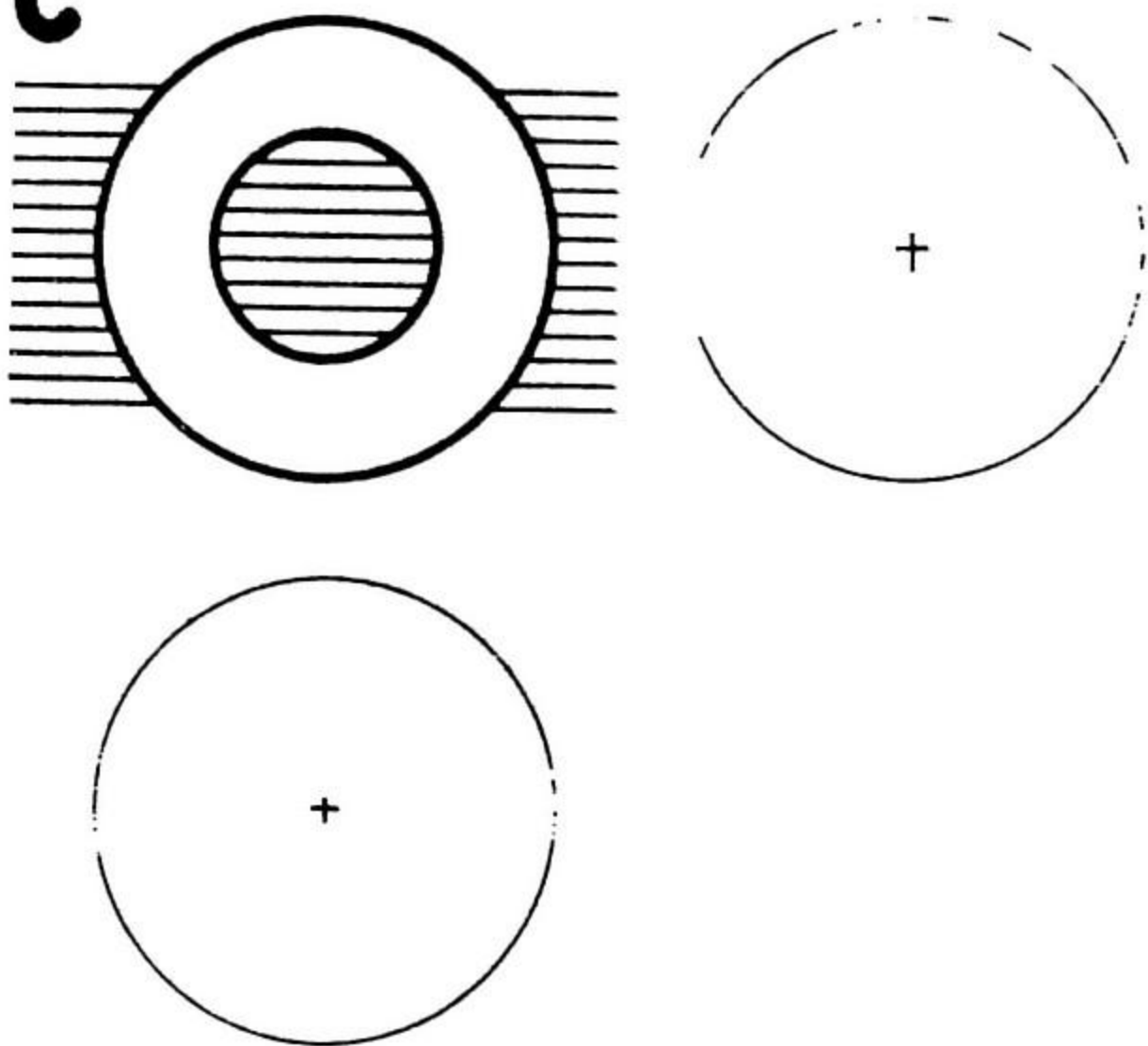

D

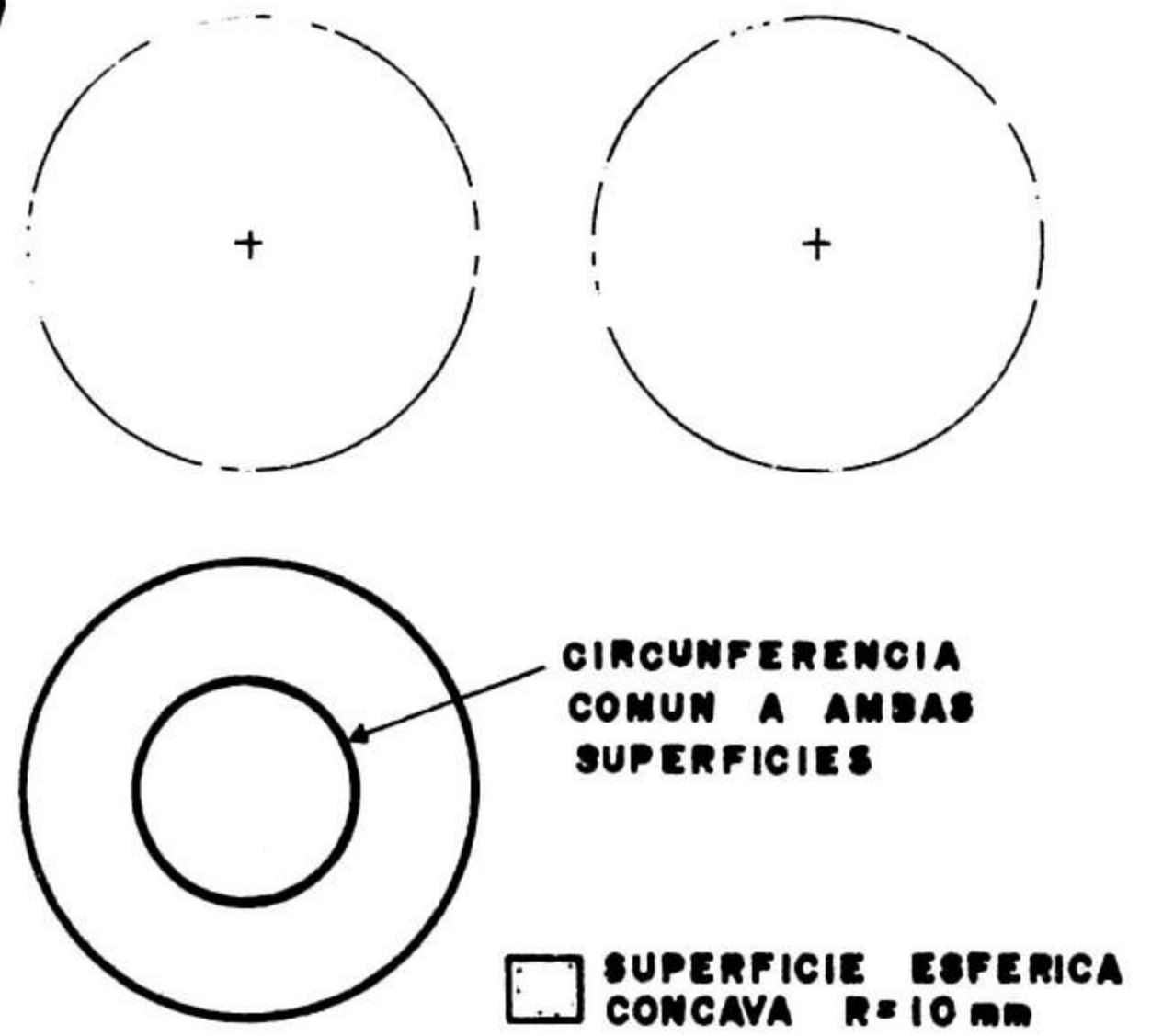

E

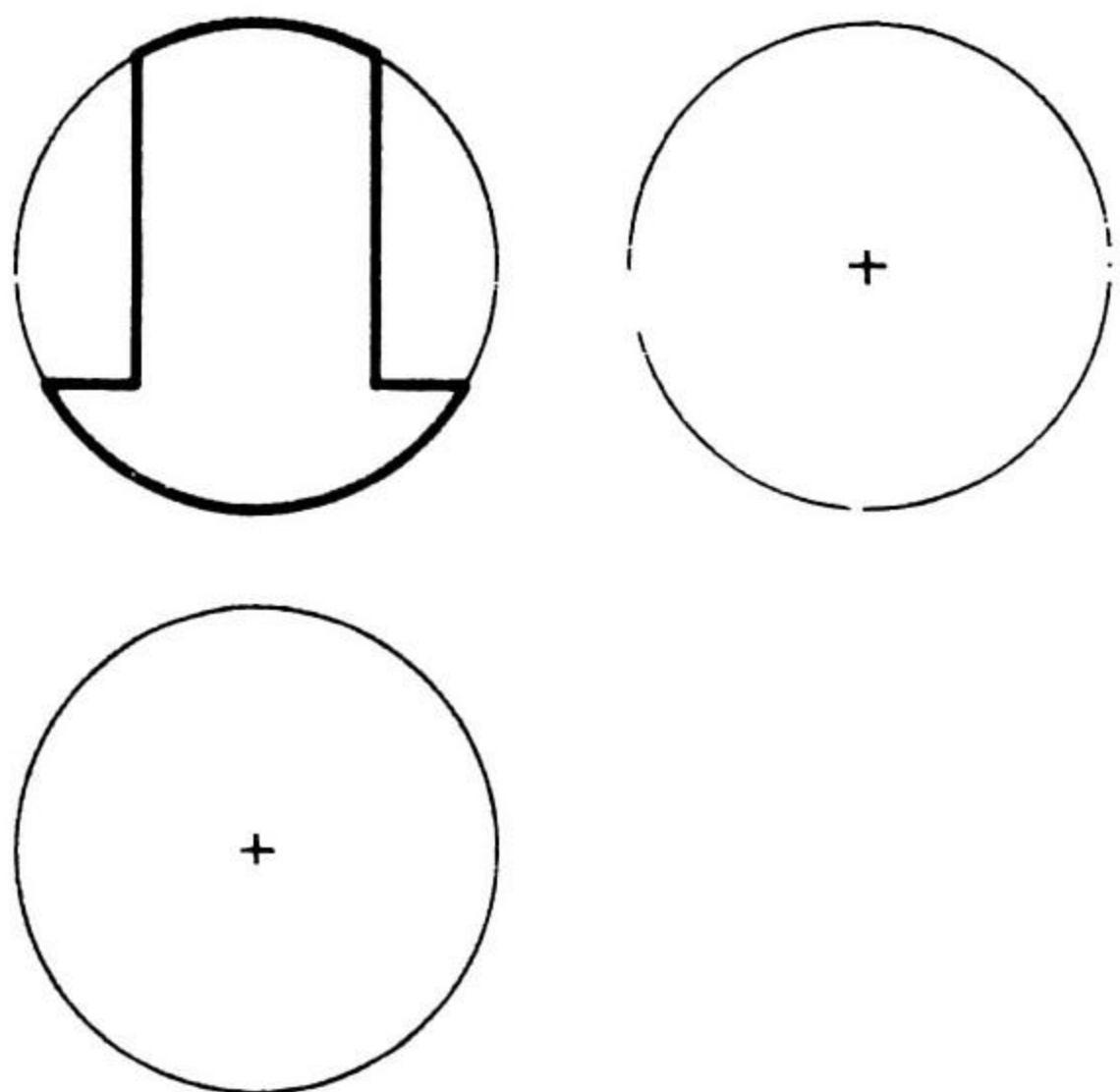

F

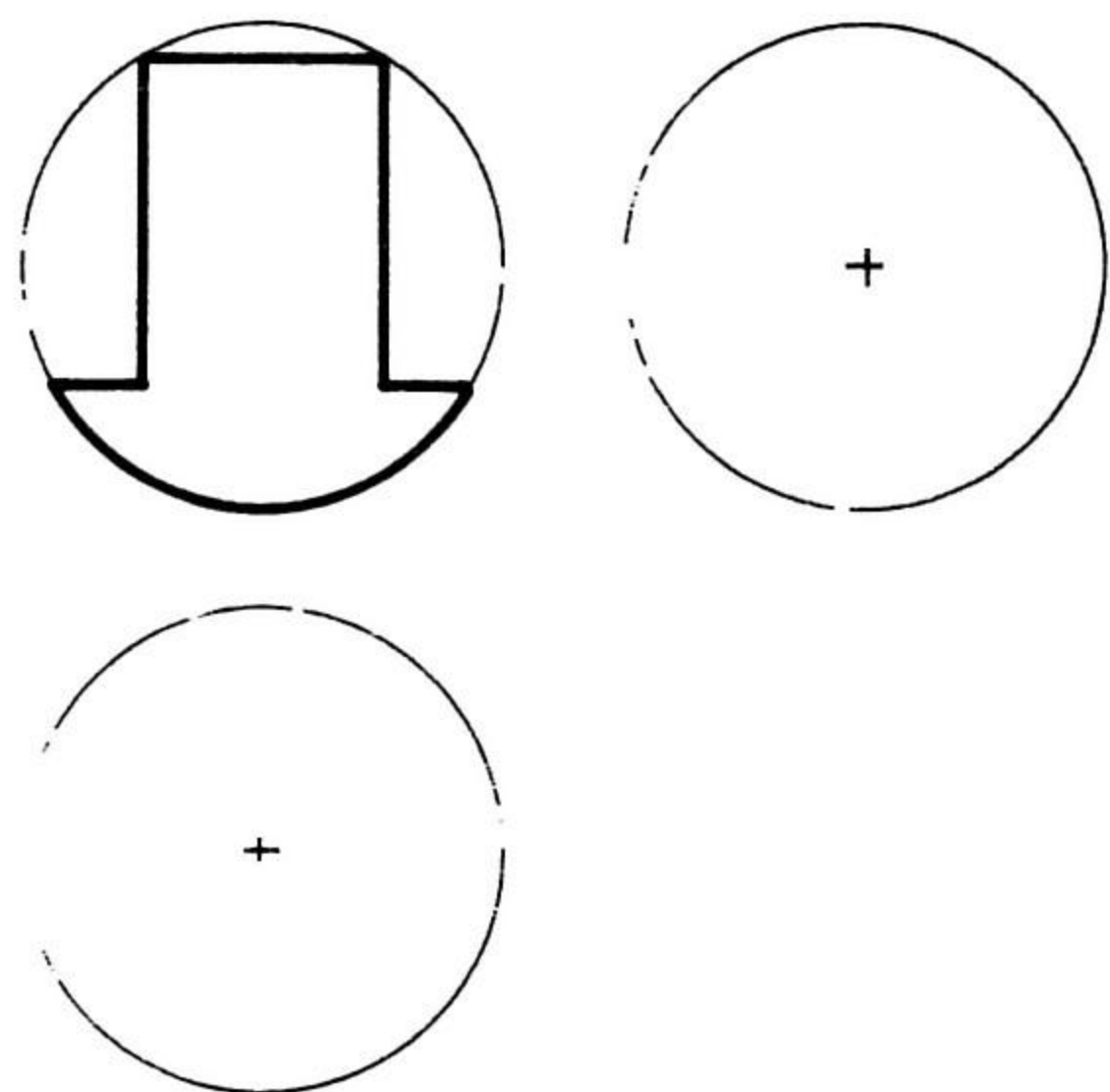

DPTO. DISEÑO BASICO

**ISPJAE
FACULTAD DE ARQUITECTURA**

ASIGNATURA

TEMA

DOC.

ALUM.

No.

OPQ.

FECHA

EVAL.



6.6 DETERMINAR LAS INTERSECCIONES Y DIBUJAR EL ISOMETRICO

A

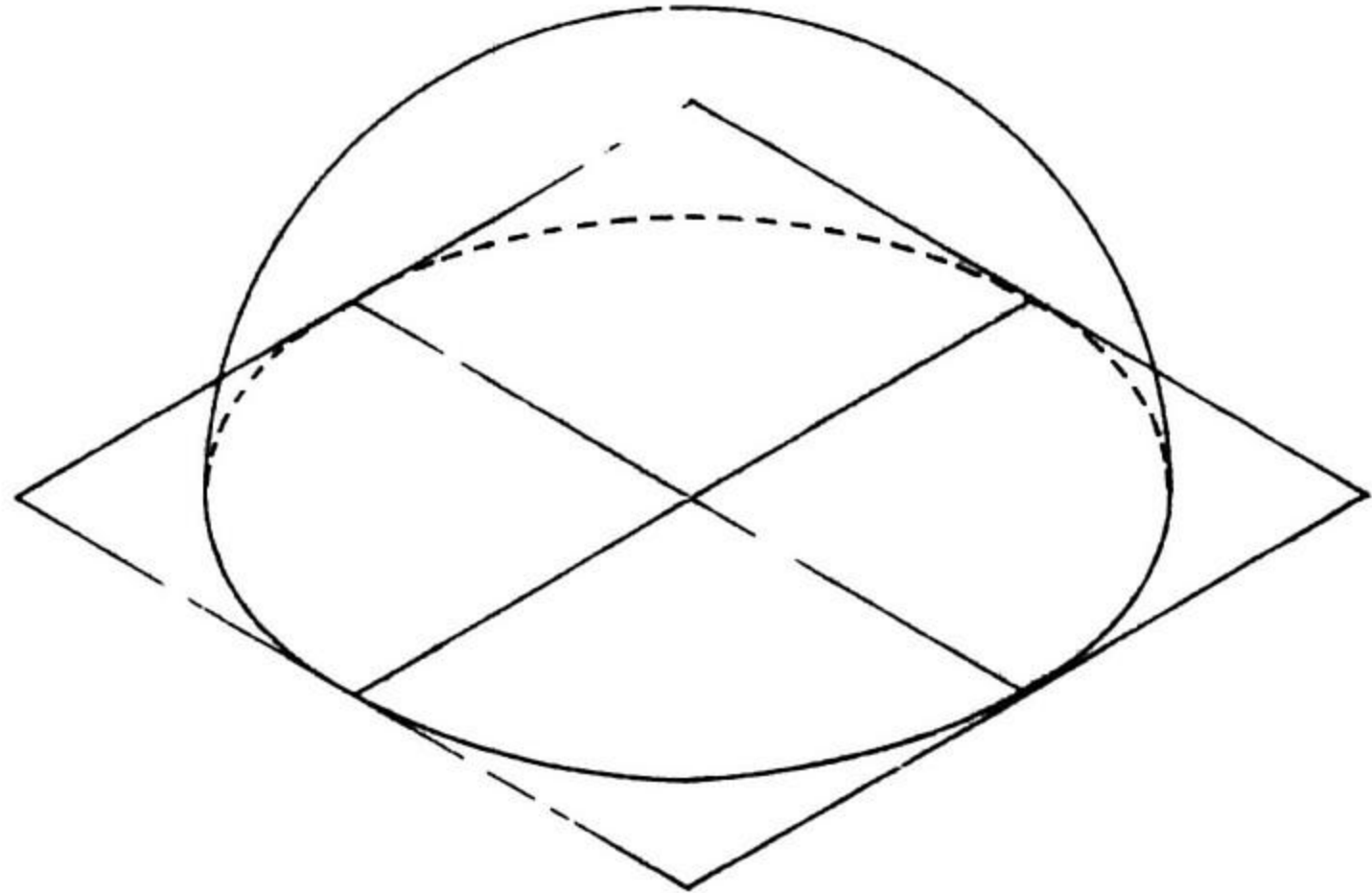
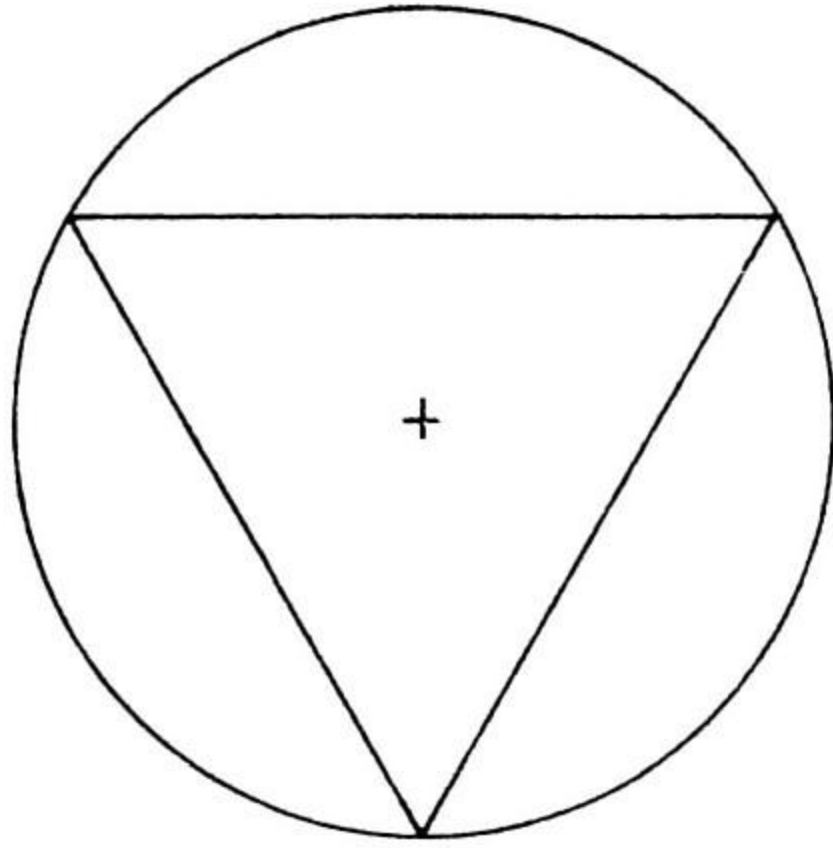
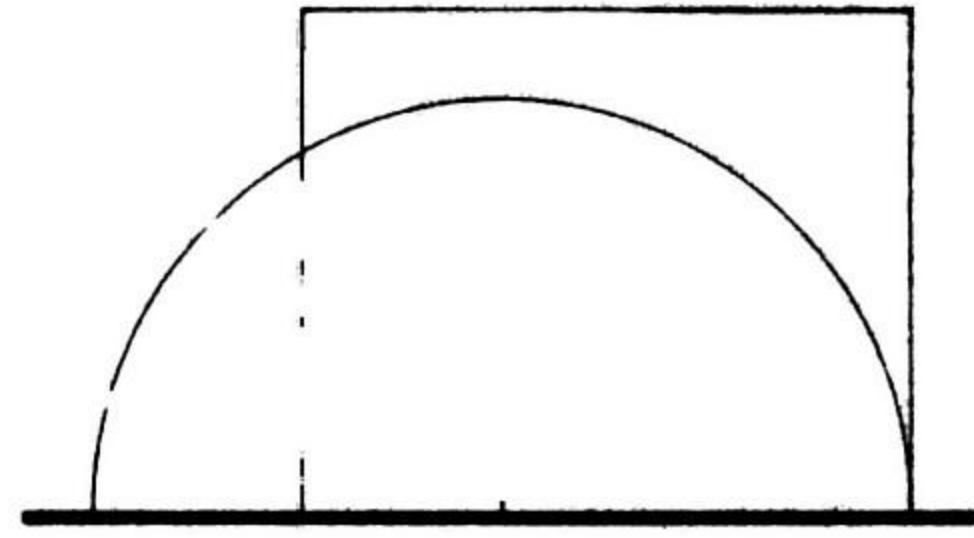
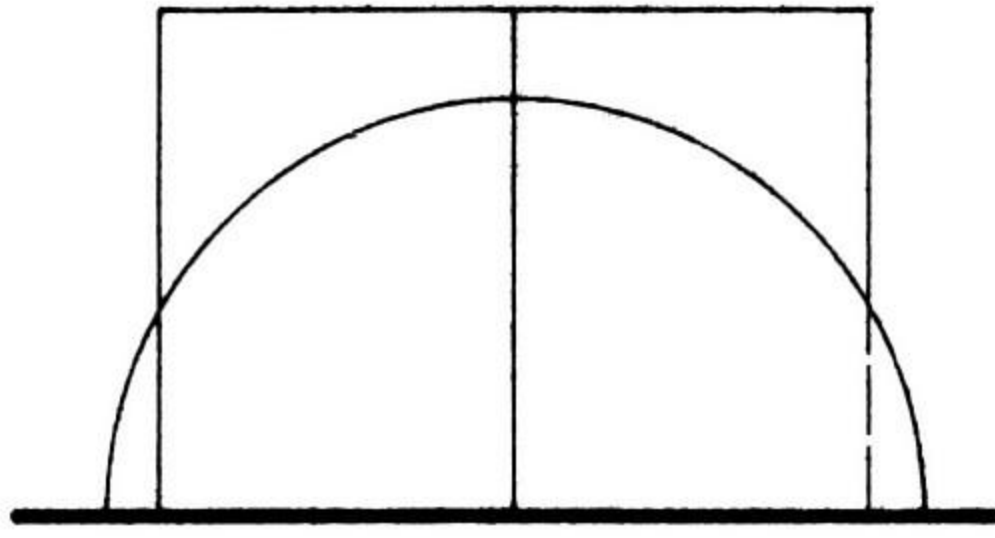

SEMIESFERA Y PRISMA RECTO DE BASE TRIANGULAR

B

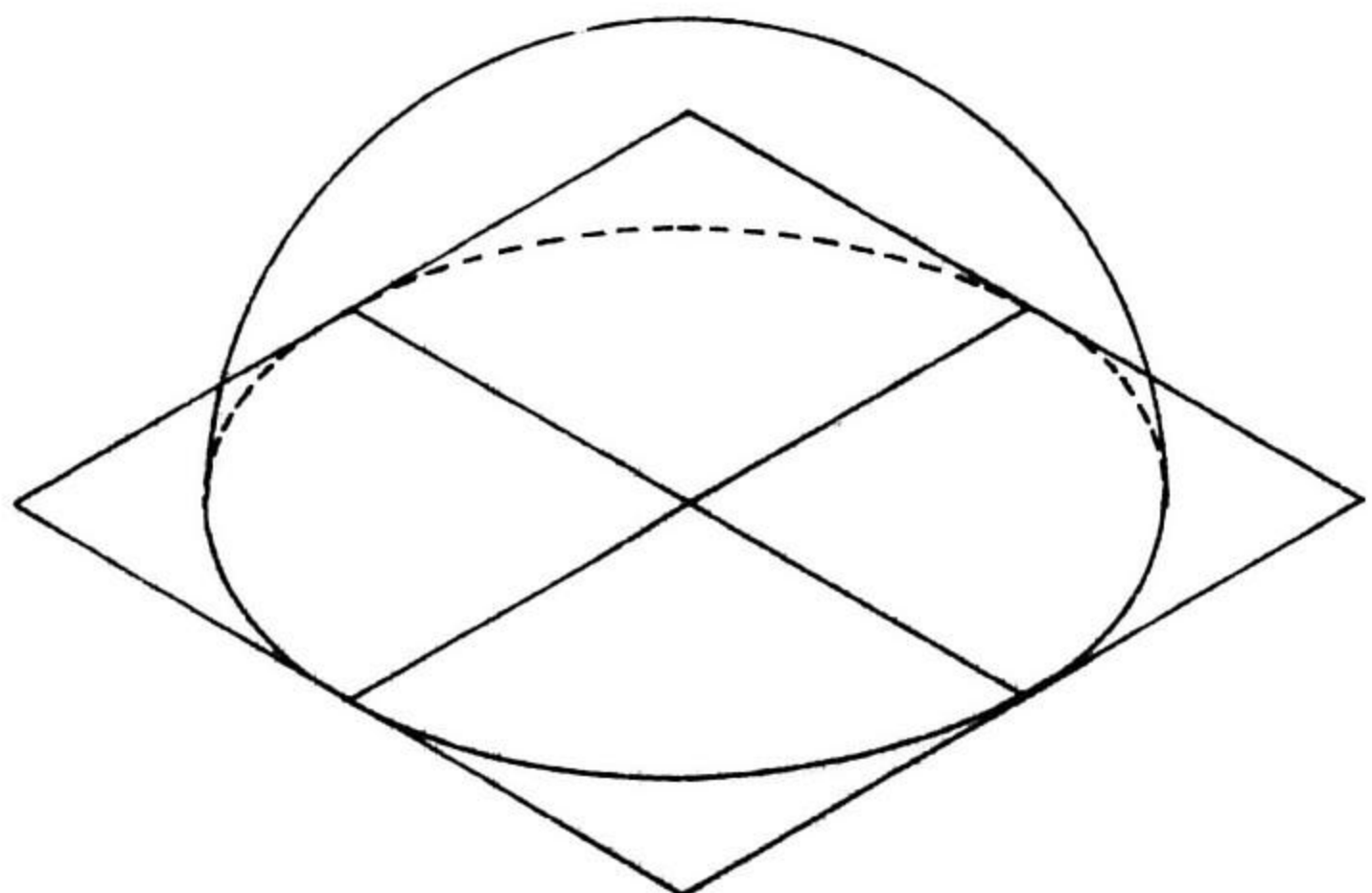
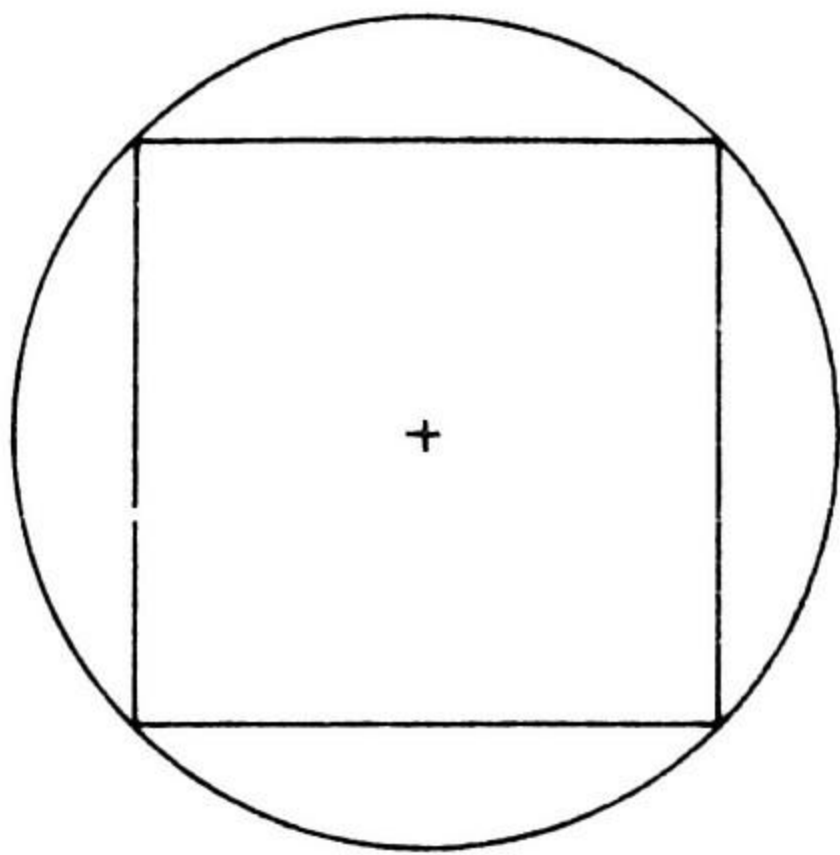
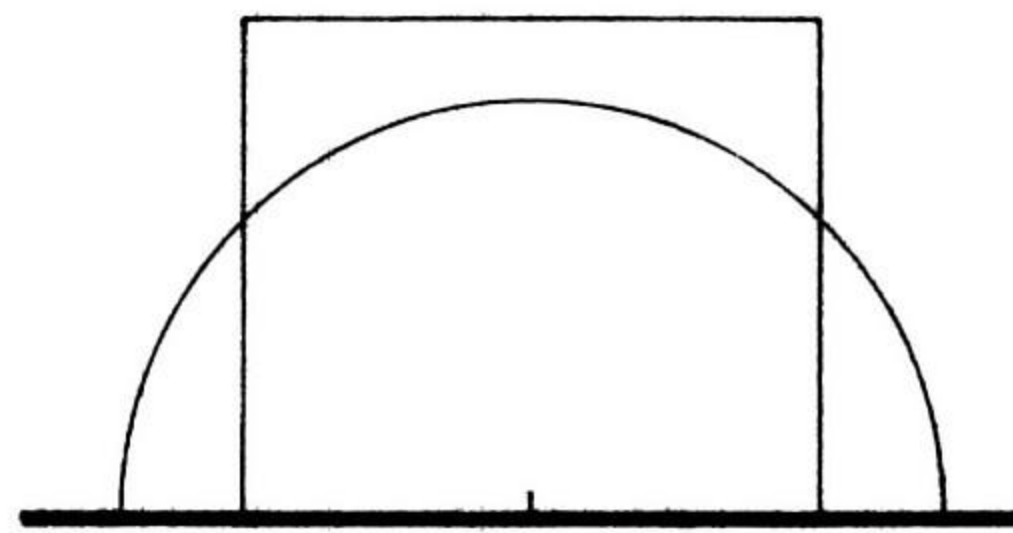
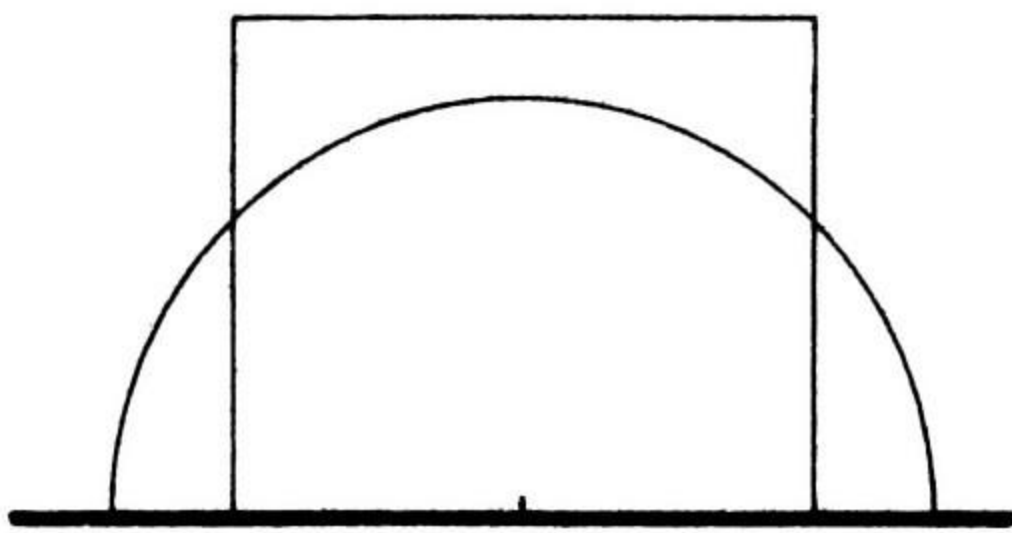

SEMIESFERA Y PRISMA RECTO DE BASE CUADRADA

DPTO. DISEÑO BASICO

ISPJAE FACULTAD DE ARQUITECTURA

ASIGNATURA

TEMA

DOC.

ALUM.

No.

GPO.

FECHA

EVAL.



6.6 INTERSECCION DE SEMIESFERA CON PRISMA RECTO DE BASE TRIANGULAR. CALCOS A PARTIR DE ISOMETRICO DE :

A INTERSECCION

B HUELLA DEL PRISMA EN LA SEMIESFERA

C HUELLA DE LA SEMIESFERA EN EL PRISMA

D SOLIDO COMUN

DPTO. DISEÑO BASICO

**ISPJAE
FACULTAD DE ARQUITECTURA**

ASIGNATURA	TEMA			D
DOC.	ALUM.	No.	GRPO.	
FECHA			EVAL.	

HELICE CILINDRICA.

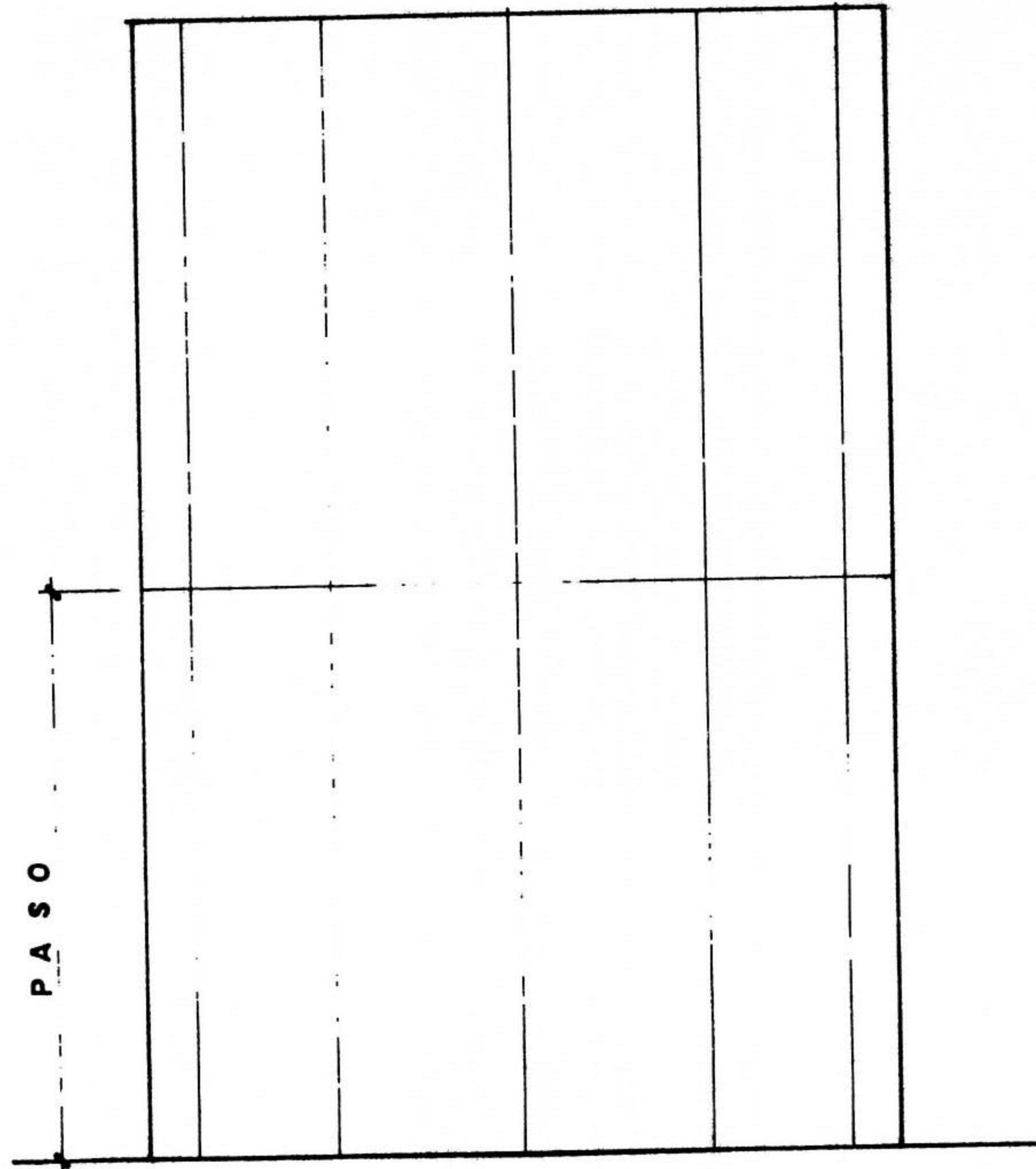

VISTA DE FRENTE

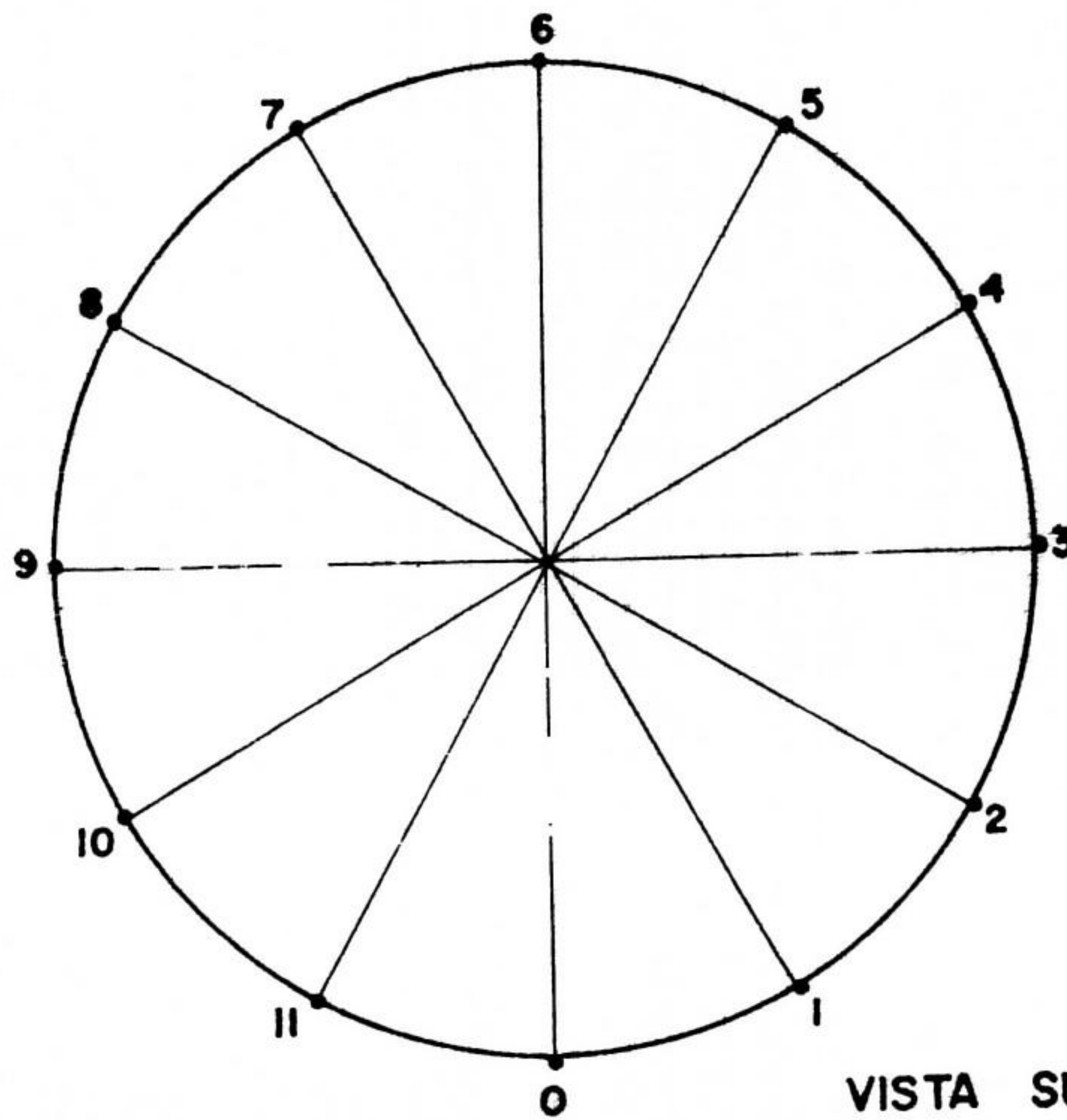

VISTA SUPERIOR

DPTO. DISEÑO BASICO		ISPJAE	
		FACULTAD DE ARQUITECTURA	
ASIGNATURA	TEMA		
DOC.	ALUM.	No.	GRPO.
FECHA		EVAL.	

1 Y 3 CIRCUNFERENCIAS FRONTALES
2 Y 4 CIRCUNFERENCIAS EN ESCORZO
 PARA CONSTRUIR CIRCULOS
 PARALELOS A LOS PLANOS: XY
 ZX
 ZY

1 (D=30mm)

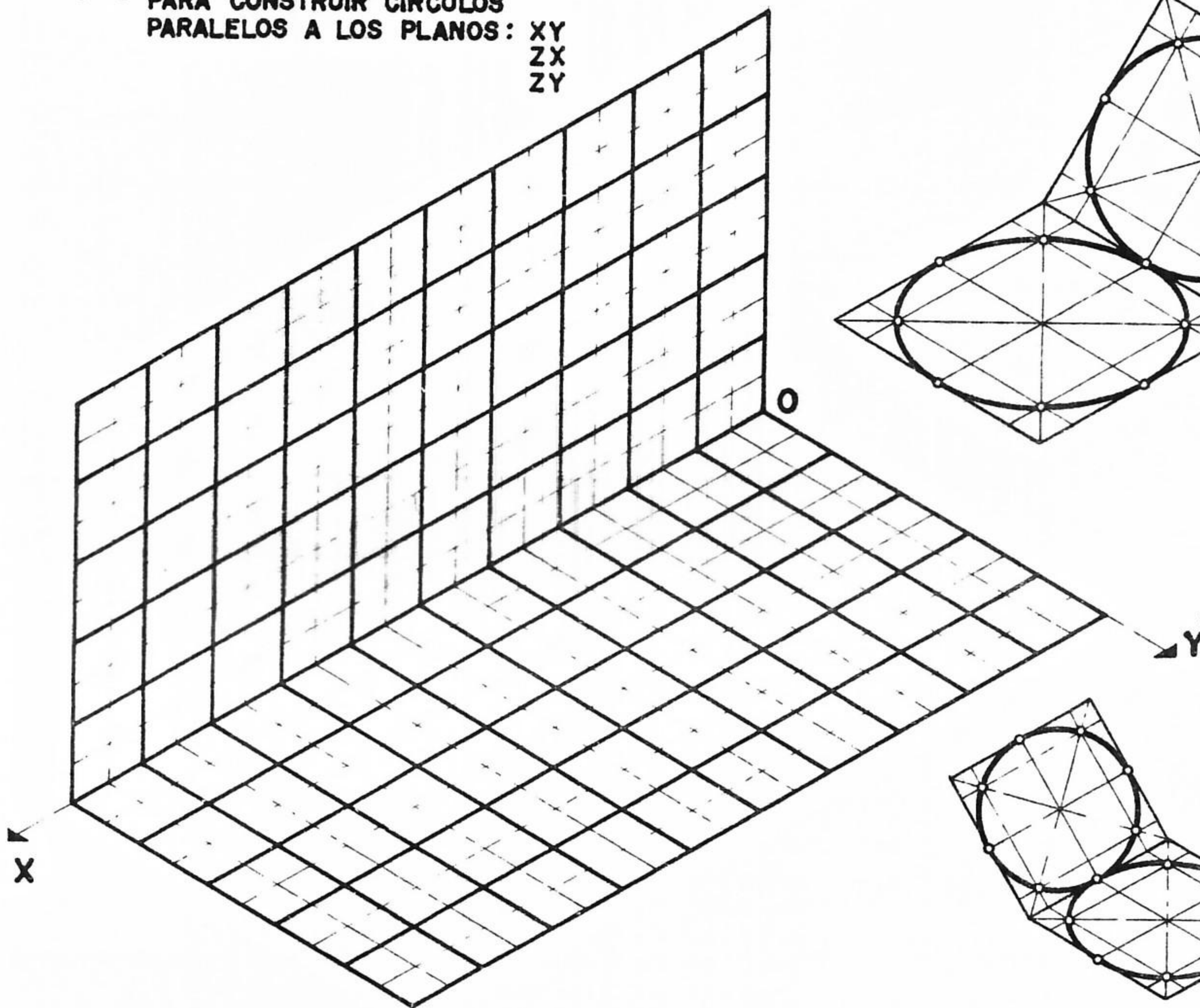

2 (D=30mm)

3 (D=20mm)

4 (D=20mm)

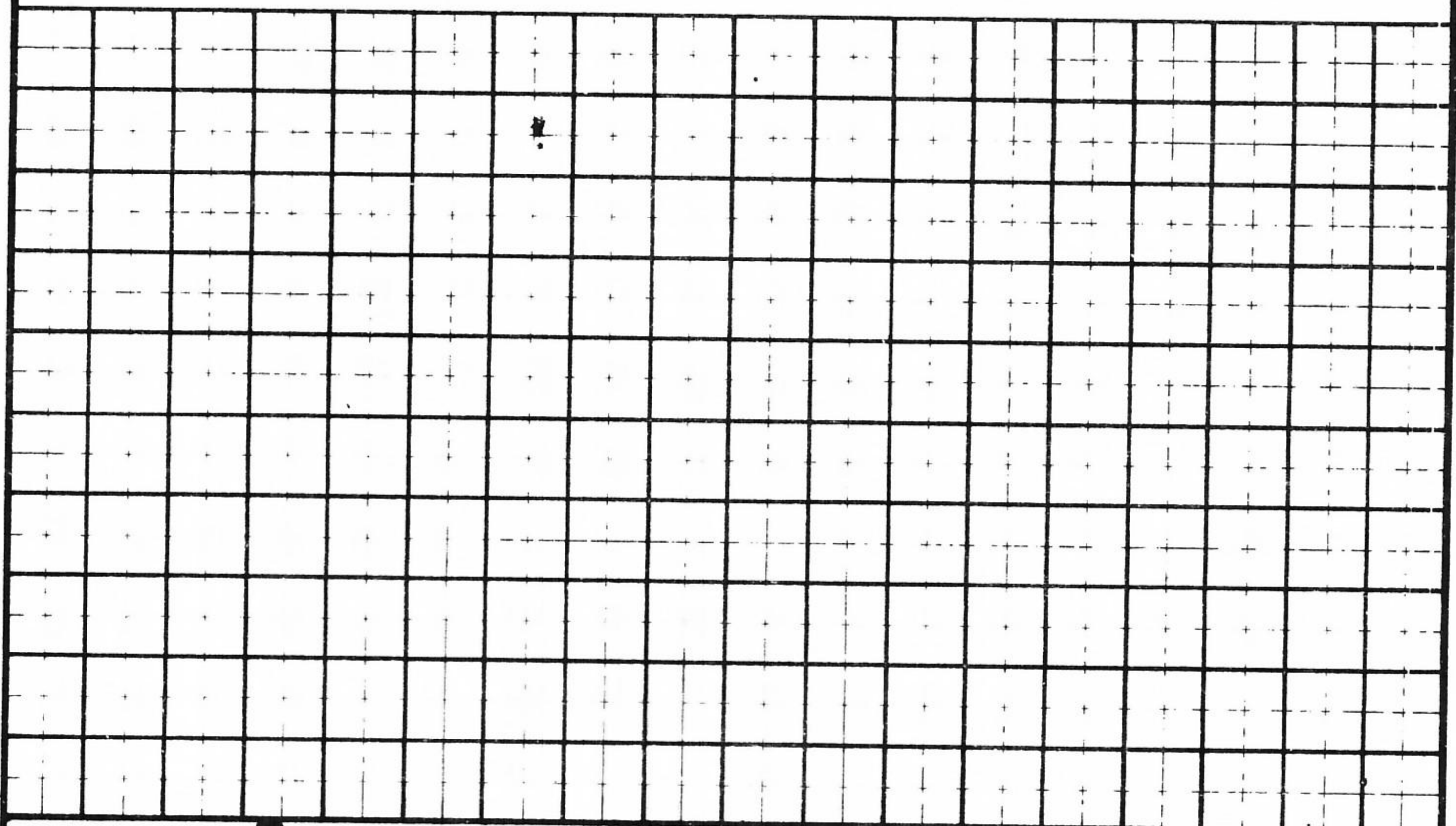

DPTO. DISEÑO BASICO

**ISPJAE
 FACULTAD DE ARQUITECTURA**

ASIGNATURA	TEMA		
DOC.	ALUM.	No.	GPO.
FECHA		EVAL.	



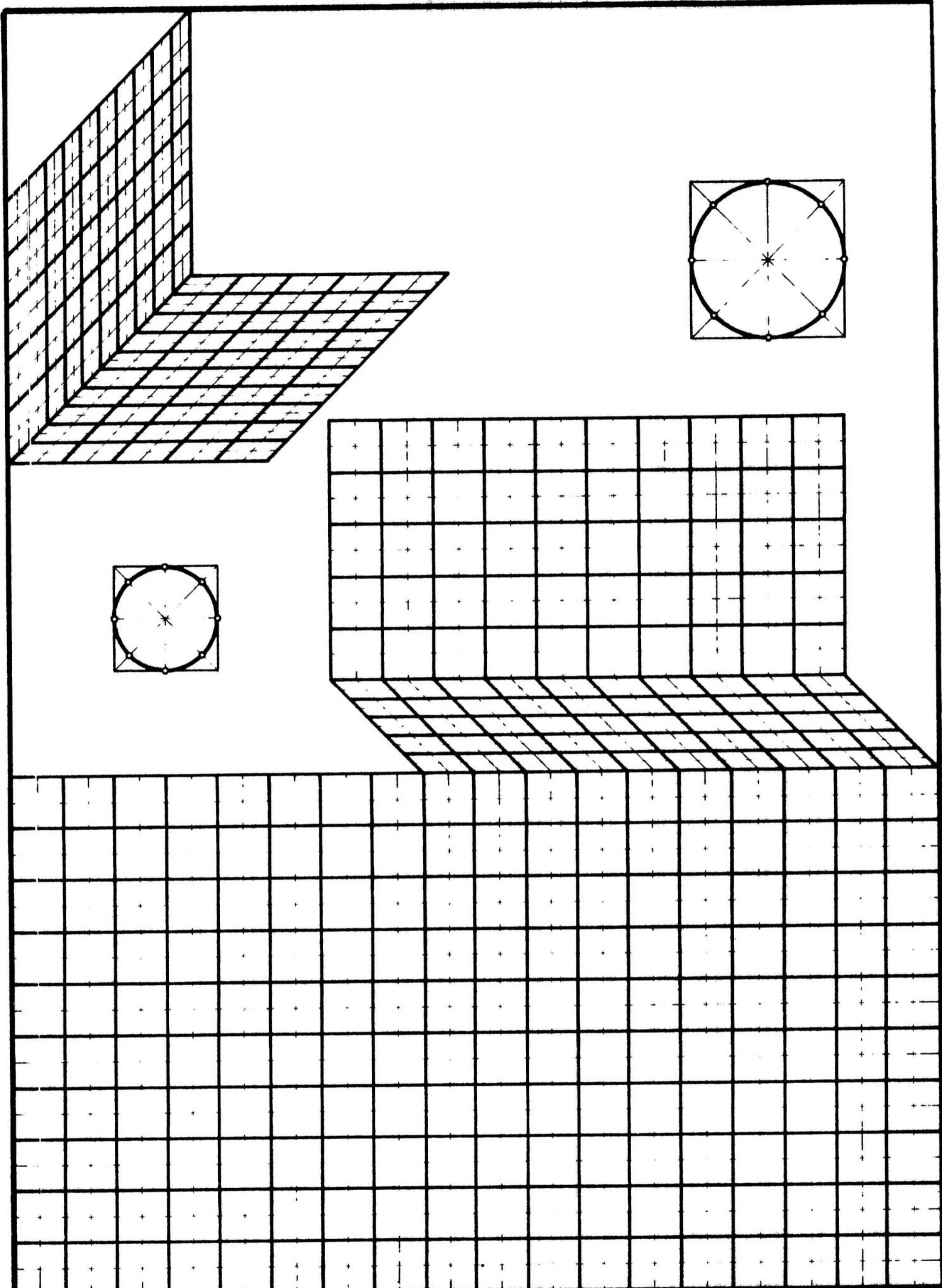

DPTO. DISEÑO BASICO		ISPJAE	
		FACULTAD DE ARQUITECTURA	
ASIGNATURA	TEMA		
DOC.	ALUM.	No.	GRPO.
FECHA		EVAL.	

