

ILLUSTRATED Maths DICTIONARY

4TH EDITION



PEARSON
Education
Australia

JUDITH DE KLERK

ILLUSTRATED
Maths
DICTIONARY

4TH EDITION

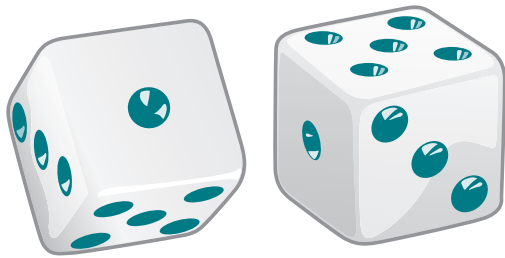

JUDITH DE KLERK



Sydney, Melbourne, Brisbane, Perth
and associated companies around the world.

Judith de Klerk passed away during the production of this fourth edition of her dictionary. She was committed to updating the dictionary and ensuring it was perfect although she was quite ill. She was assisted in all her endeavours by her husband, Louis de Klerk, who continued Judith's work.

Pearson Education Australia
A division of Pearson Australia Group Pty Ltd
Level 9, 5 Queens Road
Melbourne 3004 Australia
www.pearsoned.com.au/schools

Offices in Sydney, Brisbane and Perth, and associated companies throughout the world.

Copyright © Pearson Education Australia
(a division of Pearson Australia Group Pty Ltd) 2007
First published 1983
Reprinted 1984, 1985, 1986, 1988, 1989 (Twice)
Second edition 1990
Third edition 1999
Fourth edition 2007

All rights reserved. Except under the conditions described in the Copyright Act 1968 of Australia and subsequent amendments, no part of this publication may be reproduced, stored in a retrieval system or transmitted in any form or by any means, electronic, mechanical, photocopying, recording or otherwise, without the prior permission of the copyright owner.

Designed by Ben Galpin
Typeset by Miriam Steenhauer & Eugenio Fazio
Cover design by Ben Galpin
Cover illustrations by Ben Galpin & Boris Silvestri
Edited by Sally Green
Prepress work by The Type Factory
Produced by Pearson Education Australia
Printed in Malaysia

National Library of Australia
Cataloguing-in-Publication data
De Klerk, Judith.
Illustrated maths dictionary for Australian schools.

4th ed.
ISBN 9780 7339 8661 1

Every effort has been made to trace and acknowledge copyright. However, should any infringement have occurred, the publishers tender their apologies and invite copyright owners to contact them.

The
publisher's
policy is to use
**paper manufactured
from sustainable forests**



Contents

A-Z	1
Useful information	146
Units of measurement	146
A list of symbols	147
Roman numerals	148
Parts of a circle	148
Metric relationships	149
Formulae	150
More formulae	151
Large numbers	152
Letters used in mathematics	152
Decimal system prefixes	153
Numerical prefixes	153
Other prefixes	154
The multiplication square	154
Greek alphabet	155
Conversion tables:	
metric and imperial	156
Computing terms	158

Introduction

The language of mathematics often confuses children and it is sometimes difficult for teachers to explain the meaning of mathematical terms simply but accurately.

The fourth edition of this Illustrated Maths Dictionary offers an up-to-date dictionary of maths terms with the addition of a section explaining commonly used computer terms that have mathematical connotations. The definitions are written in simple language that children can understand, yet are clear, precise and concise. The terms are supported by hundreds of examples and illustrations.

This is essentially a dictionary for students, but I hope that teachers, parents and tertiary students will also find it helpful.

Judith de Klerk



a

(i) In formulas, the letter A stands for area.

Example

Area of a triangle

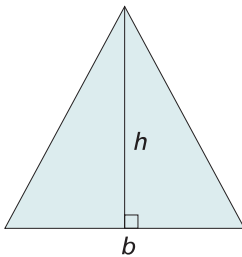

$$A = \frac{b \times h}{2}$$

(ii) A, and other letters, are used to name points, lines, angles and corners (vertices) of polygons and solids.

Examples

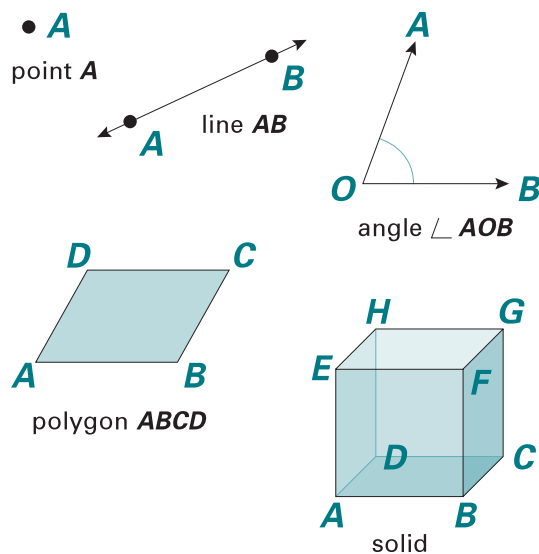

See angle name, area, formula, line, point, vertex

abacus

Usually a board with spikes or a frame with wires on which discs, beads or counters are placed. Used for counting and calculating.

Examples

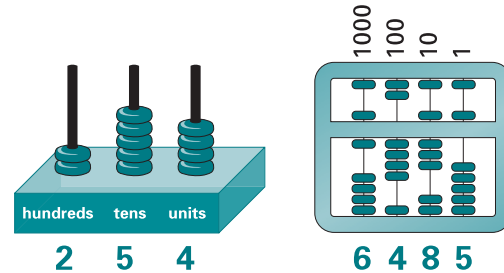

abbreviation

A shortened form of writing words and phrases.

When writing shortened forms of words, we usually put full stops after the letters.

Example

Victoria: Vic.

Note: cm (centimetre) is a symbol. We do not write full stops after symbols.

Examples

m cm mm kg mL m² cm³

See symbol

abscissa

The horizontal coordinate, or x -coordinate, of a point in a two-dimensional system of Cartesian coordinates is sometimes called the abscissa.

See axis, coordinates, ordinate



accurate

Exact, correct, right, without error.

Note: Measurements are not exact. We usually measure to the nearest unit, therefore our answers are only approximate. For example, if we say something is 30 cm long, we mean nearer to 30 cm than to either 31 cm or 29 cm.

See approximately

acute

Sharp. Sharply pointed.

(i) Acute angle.

A sharply pointed angle with size less than a right angle ($< 90^\circ$).

Examples

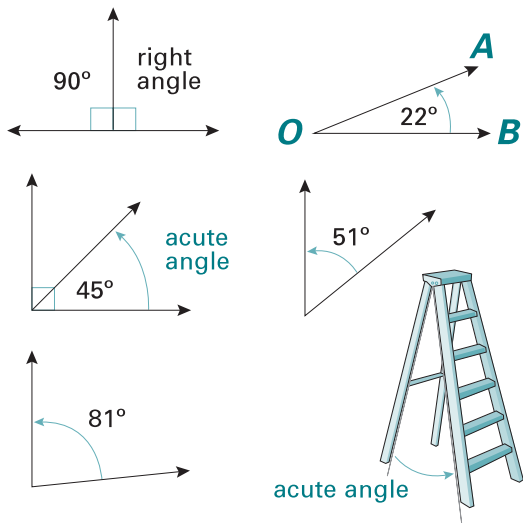

See angle, right angle

(ii) Acute triangle.

A triangle with all three inside angles being acute.

Example

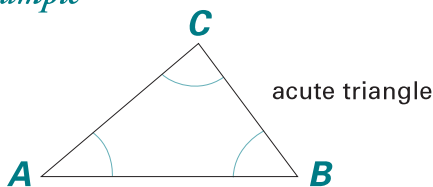

See equilateral triangle, obtuse triangle, right-angled triangle, scalene triangle

AD

(Anno Domini)

Meaning: In the year of our Lord. After the birth of Christ.

Example

The eruption of Mount Vesuvius in AD 79 destroyed Pompeii.

See BC, CE

add

Join two or more numbers or quantities together.

Example

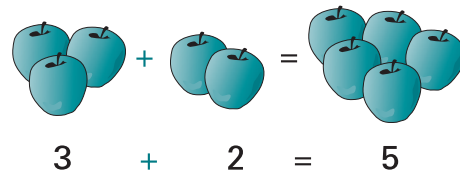

The apples were added together.

See addition, quantity

addend

Any number which is to be added.

Example

$$2 + 6 = 8$$

↑ ↑ ↑
addend addend sum

In $2 + 6 = 8$, 2 and 6 are addends, 8 is the sum.

addition

(symbol: +)

- (i) Joining the values of two or more numbers together.

$$3 + 7 = 10$$

- (ii) On the number line.

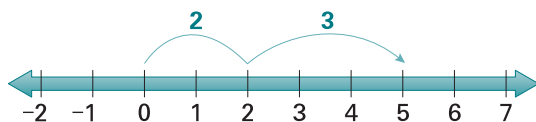

$$2 + 3 = 5$$

- (iii) Addition of fractions.

$$\frac{1}{4} + \frac{3}{5} = \frac{5+12}{20} = \frac{17}{20}$$

- (iv) Addition of integers.

$$+5 + -7 = -2$$

- (v) Addition of algebraic terms.

$$2a + 3b + 5a = 7a + 3b$$

See algebraic expression, fraction, integers, number line

addition property of zero

When zero is added to any number, the sum is the same as the number.

Examples

$$4 + 0 = 4$$

$$0 + 12 = 12$$

See sum, zero

additive inverse

When we add a number and its inverse, the answer is zero.

Example

$$8 + -8 = 0$$

↑ ↑

number inverse

See inverse, zero

adjacent

Positioned next to each other, having a common point or side.

Example

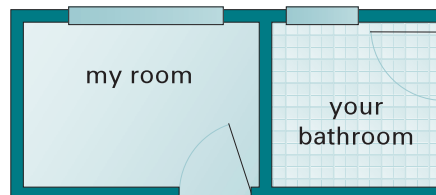

My room is adjacent to your bathroom.

- (i) Adjacent sides.

Example

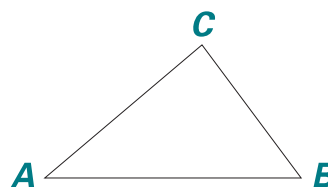

In this triangle, side AB is adjacent to side AC because they have a common vertex A .

- (ii) Adjacent angles.

Two angles positioned in the same plane that have a common side and a common vertex.

Example

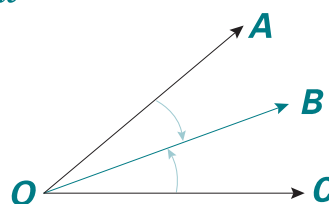

$\angle AOB$ is adjacent to $\angle BOC$ because they have a common ray \vec{OB} .

See plane, vertex

algebra

Part of mathematics that studies number systems and number properties.

See algebraic expression, coefficient, numeral, pronomeral, symbol, variable





algebraic expression

In algebra we use numerals, symbols and letters called variables or pronumerals, and combinations of both. They stand for the unknown values.

Examples

$$\text{flower} + \text{flower} = 2 \text{ flowers}$$

$$5 - x$$

$$a + b + c$$

$$x^2 - 2xy + y$$

See coefficient, numeral, pronumeral, symbol, value, variable

algorithm

(algorism)

A rule for solving a problem in a certain number of steps. Every step is clearly described.

Example

Use blocks to find how many 3×4 is.

Step 1 Lay down one lot of four blocks.



Step 2 Put down the second and third lots of four.

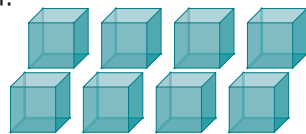

Step 3 Exchange 10 units for one ten (long).

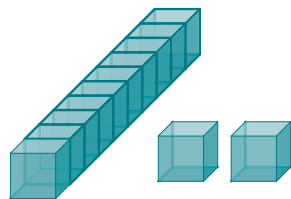

Step 4 Write down your answer.

$$3 \times 4 = 12$$

See multibase arithmetic blocks (MAB)

align

Lay, place in a straight line.

Example

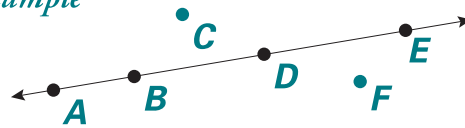

Points *A*, *B*, *D* and *E* are aligned; points *C* and *F* are not.

See line

alternate angles

See parallel lines

altitude

Height. How high something is above the surface of the Earth, sea level or horizon. Altitude is the length of perpendicular height from base to vertex.

Example

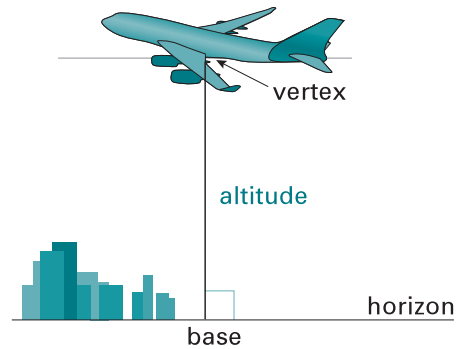

The altitude of this aeroplane is 9000 metres.

See height, perpendicular, surface

a.m.

(ante meridiem)

The time from immediately after midnight until immediately before midday. The term a.m. is used only with 12-hour time.

Example

It is morning.

The time is five past five.

It is 5.05 a.m.

See p.m.

**amount**

An amount of something means how much of that thing.

Example

The amount of money in my pocket.

analogue clock

A clock or a watch that has numerals 1–12 on its face, and two hands pointing at them to show the time.

Example

This clock shows twenty-five minutes past nine in the morning.

It is 9.25 a.m.

See a.m., digital clock, p.m.



Angle is the inclination of two lines to each other.

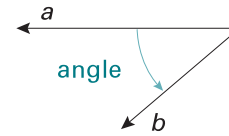

Angles are measured in degrees ($^{\circ}$), minutes ($'$) and seconds ($''$).

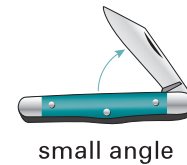
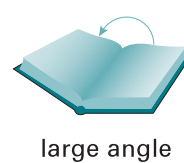
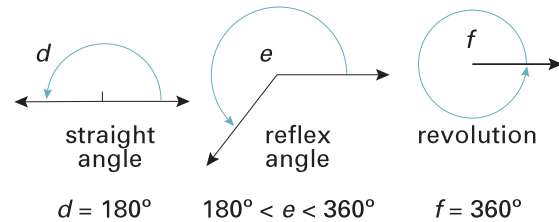
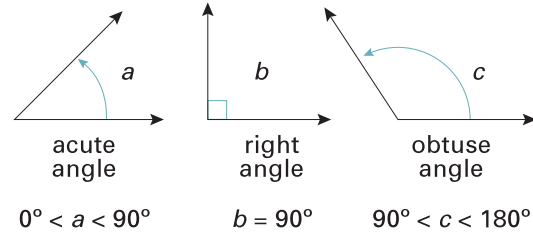

See acute, degree, obtuse angle, parallel lines, ray, reflex angle, revolution, right angle, straight angle

angle

The space between two straight lines with a common end point (vertex).

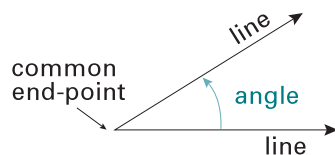

An angle is the amount of turn of a ray about a fixed point.

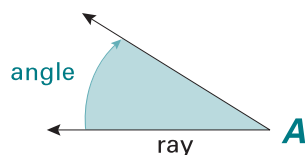
**angle name**

Angles are given names by marking them with letters.

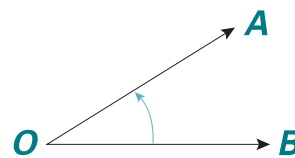
Example

The name of this angle is $\angle AOB$. The letter O in the middle ($\angle AOB$) indicates the common end point.



angle of depression

(of an object)

An angle formed between the horizontal line and the line of sight to an object below.

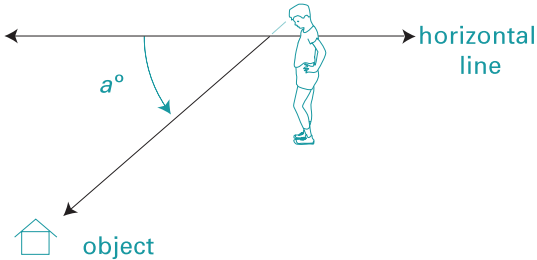

The angle of depression is a° .

See angle of elevation

angle of elevation

An angle formed between the horizontal line and the line of sight to an object above.

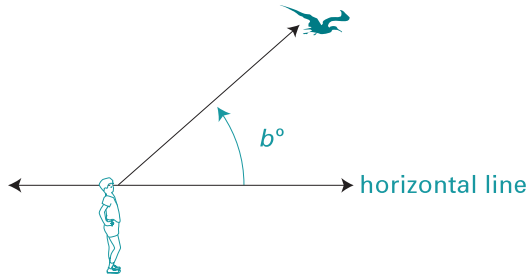

The angle of elevation is b° .

See angle of depression

angle sum

The total amount of degrees in any polygon.

(i) Angle sum of a triangle is 180° .

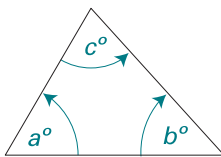

$$a^\circ + b^\circ + c^\circ = 180^\circ$$

(ii) Angle sum of a quadrilateral is 360° .

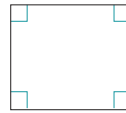

$$4 \times 90^\circ = 360^\circ$$

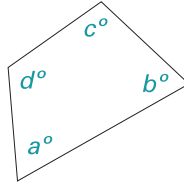

$$a^\circ + b^\circ + c^\circ + d^\circ = 360^\circ$$

(iii) Angle sum of any polygon may be found:

$$\begin{aligned} &\text{number of vertices} \times 180^\circ - 360^\circ \text{ or} \\ &(\text{number of vertices} - 2) \times 180^\circ \end{aligned}$$

Examples

triangle $(3 \times 180^\circ) - 360^\circ = 180^\circ$ or $(3 - 2) \times 180^\circ = 180^\circ$

pentagon $(5 - 2) \times 180^\circ = 540^\circ$

hexagon $(6 \times 180^\circ) - 360^\circ = 720^\circ$

annual

(i) Happening only once a year.

Example

Annual flower show.

(ii) Recurring yearly.

Example

Annual rate of interest is 6.5%.

See per annum, per cent

annulus

The area between two concentric circles.

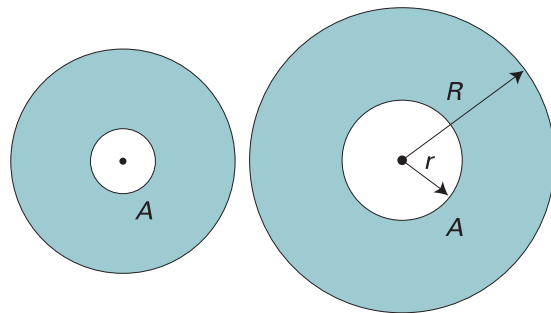

$$A = \pi (R^2 - r^2)$$

See area, circle, concentric circles

anticlockwise

The direction opposite to that in which the hands of a clock travel.

Example



This clock is fifteen minutes fast. The hands must be moved back to show the exact time.



The hands have been moved in an anticlockwise direction.

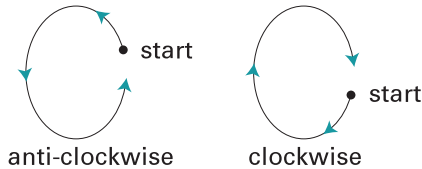

Example

Screws and bottle tops are loosened in an anticlockwise direction.

See clockwise

apex

The highest point where two or more lines meet to form a corner of a figure or solid. The apex is the furthest vertical distance from the base.

Examples

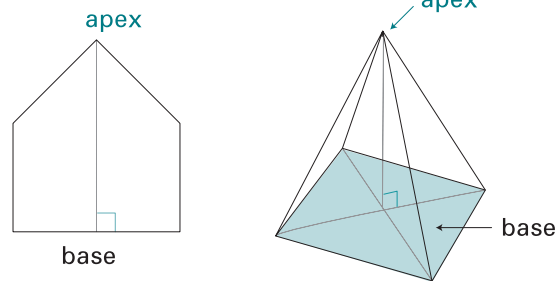

See base, pyramid, vertex

approximately

(symbols: \approx \doteq \simeq)

Nearly, not exactly, but almost. The symbols \approx or \doteq or \simeq may be used for 'is approximately equal to'.

Example

The expressions

$$0.97 \approx 1 \quad 0.97 \doteq 1 \quad 0.97 \simeq 1$$

all mean '0.97 is approximately equal to 1'.

See accurate, rounding

approximation

(symbols: \approx \doteq \simeq)

A result which is nearly, not exactly, but almost accurate. One method of approximation is calculating with rounded figures.

Examples

(i) $798 \times 2.1 \approx 800 \times 2 \approx 1600$

(ii) The value of 3.14 for π is only an approximation.

See accurate, approximately, rounding

Arabic numerals

1, 2, 3, 4, 5 ... Now in common use in all western countries.

See Hindu–Arabic





arbitrary unit

Something to help us measure.

Examples

Handspan, pace, counters, tiles, cubes, squares and bottle tops are arbitrary units.

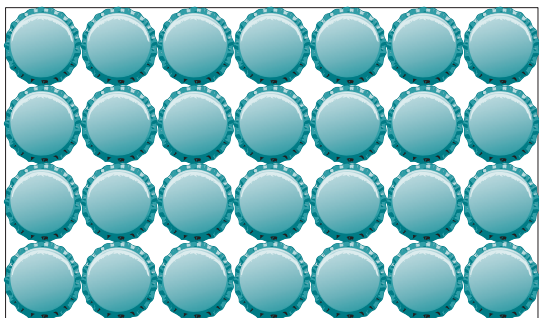

The area of this rectangle has been measured in bottle tops. The area is twenty-eight bottle tops.

See handspan

arc

A part of any curve, but most often used to mean a part of a circle.

Example

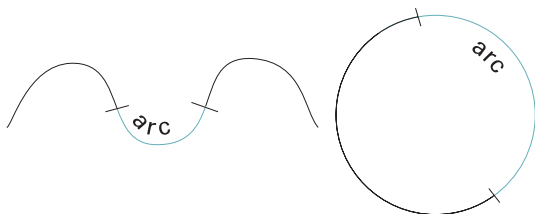

See circle, curve

are

Unit of area in the metric system. It is the area of a square with sides measuring 10 metres.

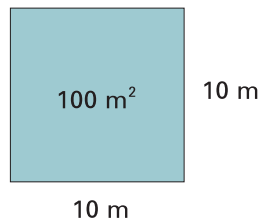

$$100 \text{ m}^2 = 1 \text{ are}$$

$$100 \text{ are} = 1 \text{ ha}$$

See area, hectare

area

The amount of surface or the size of a surface. Area is measured in square units. Units of area are:

square centimetre	cm ²
square metre	m ²
hectare	ha
square kilometre	km ²

Example

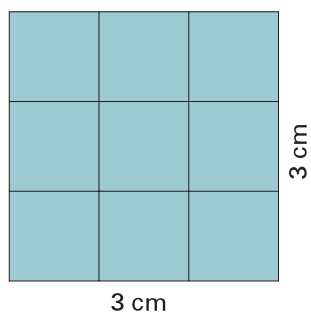

The area of this shape is
base × height
 $3 \text{ cm} \times 3 \text{ cm} = 9 \text{ cm}^2$

See conservation of area, formula, surface, unit of measurement

arithmetic

The part of mathematics concerned with the study of numbers. Arithmetic is used for computations with whole numbers, fractions and decimals. The computations include addition, subtraction, multiplication and division. Arithmetic is also used for measurement, solving word problems and working with money.

See computation

arithmetic mean

See average, mean

arithmetic progression

See progression

arm of an angle

One of the lines which make an angle.

Example

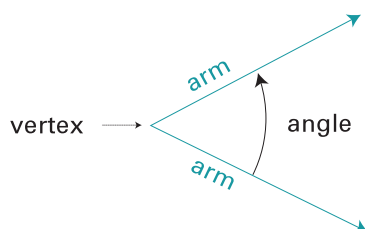

See angle, vertex

array

Arrangement of objects or numbers, in columns or rows.

Examples

	3	7	12
	5	8	10
	4	16	32
			

An array of objects in rows and columns

These numbers form an array.

arrow

Used to indicate direction.

Example

Weather vane



arrow diagram

A diagram using arrows to show a relation (or connection) between one thing and another.

Examples

(i) Relation in one set of numbers

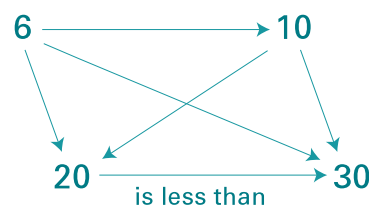

(ii) Relation between two sets

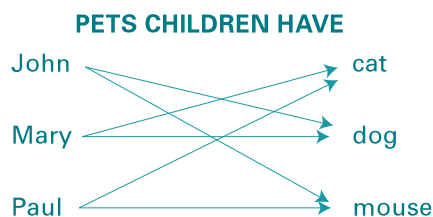

See many-to-one correspondence, mapping, one-to-one correspondence, relation, set





ascending order

Going upwards or increasing in value.

Examples

These numbers are in ascending order:

0.1, 0.2, 0.3, 0.4, 0.5
 ↑ ↑
 smallest largest

These lengths have been arranged in ascending order:

5 cm, 50 cm, 5 m, 5 km, 50 km
 ↑ ↑
 shortest longest

See descending order, increase, order, pattern, sequence

askew

Oblique or awry.

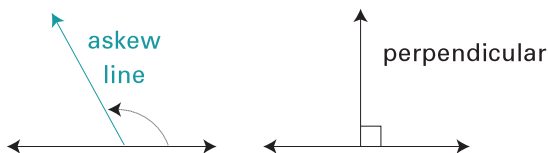

See oblique, perpendicular

associative property of addition

When adding three or more numbers together, it doesn't matter which two numbers we add first, we always get a correct answer (sum).

Example

$$\begin{aligned}
 & 3 + 7 + 9 \\
 & = (3 + 7) + 9 \quad \text{or} \quad 3 + (7 + 9) \\
 & = 10 + 9 = 19 \quad \quad = 3 + 16 = 19
 \end{aligned}$$

See commutative property of addition, sum

associative property of multiplication

When multiplying three or more numbers together, it doesn't matter which two numbers we multiply first, we always get a correct answer (product).

Example

$$\begin{aligned}
 & 3 \times 7 \times 9 \quad \text{or} \\
 & = (3 \times 7) \times 9 \quad \quad 3 \times (7 \times 9) \\
 & = 21 \times 9 \quad \quad \quad 3 \times 63 \\
 & = 189 \quad \quad \quad = 189
 \end{aligned}$$

See communicative property of multiplication, product

asterisk

A small star * used to mark a space where something is missing.

Examples

- $3 * 2 = 6$ * means \times (multiply)
- $3 * 2 = 5$ * means $+$ (add)
- $3 * 2 = 1$ * means $-$ (subtract)
- $3 * 2 = 1.5$ * means \div (divide)

asymmetry

Not having symmetry.

An object which has no line symmetry is described as asymmetrical.

Examples



The butterfly is symmetrical.

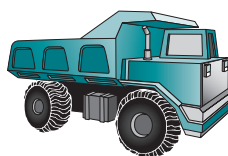

This picture of a toy truck is asymmetrical.

See line of symmetry, symmetry

attribute

A characteristic of an object.

Examples

Shape, size, colour.

- (i) Attributes of shape:
round, square, hexagonal ...



round and thin

- (ii) Attributes of size:
thick, thin, small, big ...

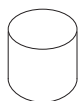

round and thick

- (iii) Attributes of colour:
black, red, yellow ...



square and black

Other classifications different from the examples above are clearly possible.

ATTRIBUTES OF CHILDREN

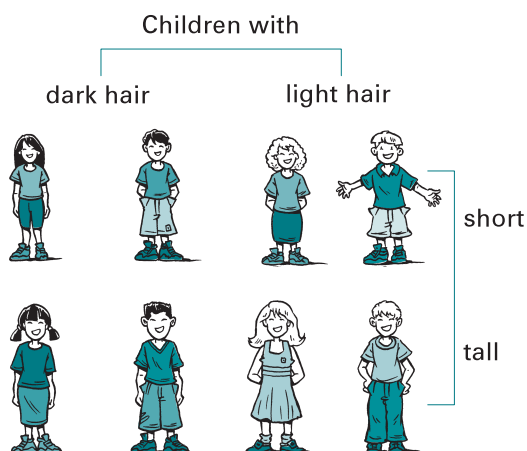

See classify, property

average

The average of a collection of numbers or scores is one score which represents the whole collection. It is found by adding all of the scores and dividing the answer (sum) by the number of scores.

Example

Find the average of scores 2, 5, 4, 6 and 3.

$$\begin{aligned} \text{Average} &= \frac{\text{sum of scores}}{\text{number of scores}} \\ &= \frac{2 + 5 + 4 + 6 + 3}{5} \\ &= \frac{20}{5} \end{aligned}$$

$$\text{Average} = 4$$

This is also called the mean or arithmetic mean.

See mean, score, sum





axis

(Plural: axes)

- (i) The lines which form the framework for a graph. The horizontal axis is called x -axis, the vertical axis is called y -axis. Both axes are marked with equally spaced scales. The point where the axes intersect is called the origin (O).

Example

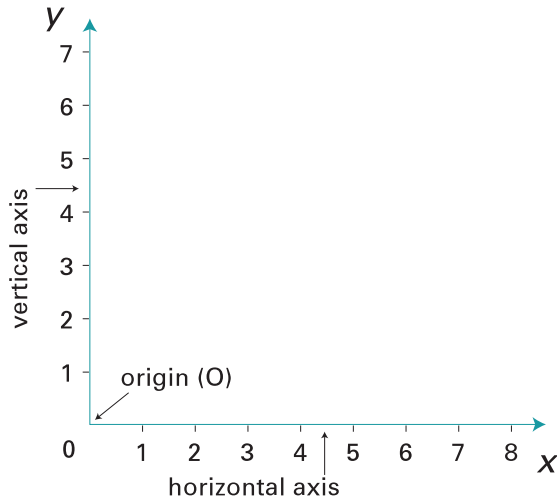

Axes are sometimes called:

x -axis = abscissa

y -axis = ordinate

- (ii) A main line going through the centre of a figure or solid, also called a line of symmetry, or an axis of symmetry.

Examples

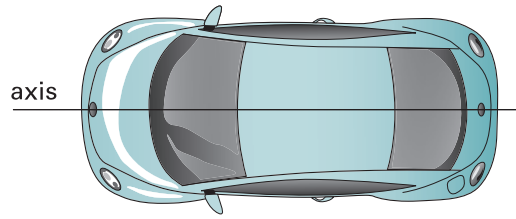
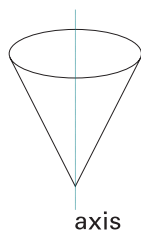
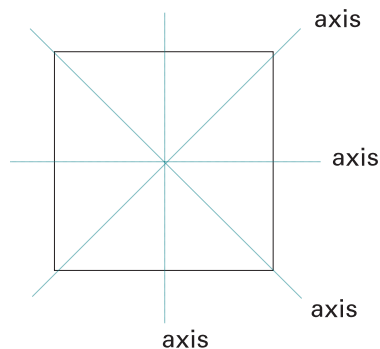

See coordinates, graph, horizontal line, intersection, line of symmetry, origin, vertical

axis of symmetry

See axis, line of symmetry

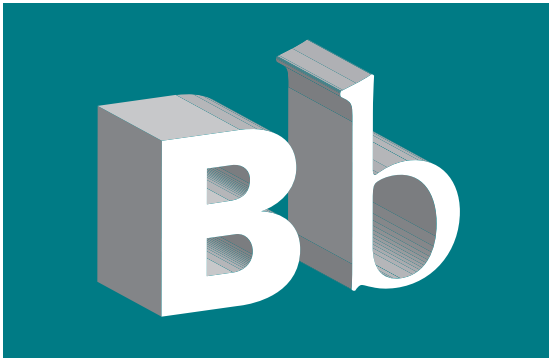

balance

(i) An equal distribution.

Example



balanced

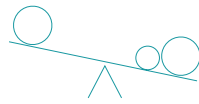

unbalanced

(ii) Balance scales is a name given to some kinds of scales used for weighing things.

Example



a spring balance

See beam balance

(iii) The amount of money in a bank account.

Example

Date	Description	Credit	Debit	Balance
2006				
02 Feb	Pay	350		
05 Feb	ATM withdrawal		200	150
10 Feb	Rent		50	100
16 Feb	Pay	350		450
21 Feb	Rates		295	155

bar graph

A graph which uses horizontal or vertical bars to represent various kinds of information.

A bar graph with vertical bars or columns is also called a column graph.



Examples

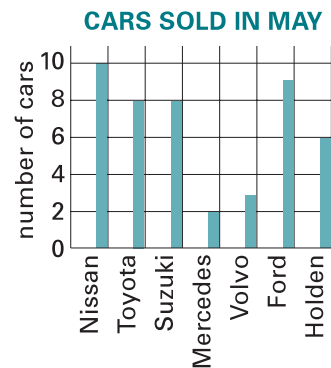
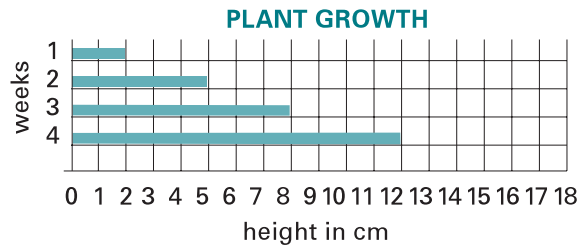

See column graph, graph, pie graph, pictograph

base

(i) The face on which a shape or a solid stands.

Examples

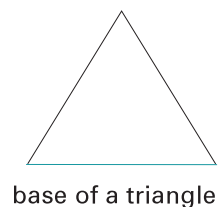
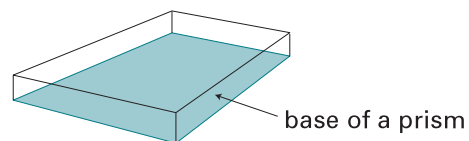

▼ base continued...



(ii) The number on which a place value system of numeration is constructed.

Example

hundreds	tens	units	tenths

100x bigger (from units to hundreds)
 10x bigger (from units to tens)
 10x smaller (from units to tenths)

The Hindu–Arabic system is a base 10 system.

(iii) A number, symbol or a variable used with index to show an index notation.

Examples

In index notation, the base is the number we read first.

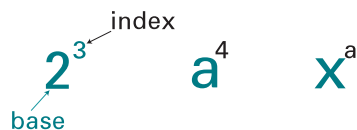

In 2^3 , read ‘two cubed’, 2 is called the base.

See decimal place-value system, exponent, index, index notation, power of a number

base line

(i) The horizontal axis of a graph.

Example

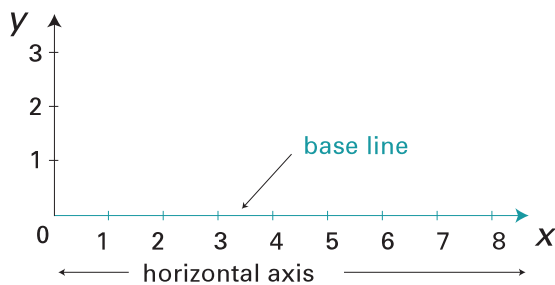

(ii) A base from which the heights of objects may be compared.

Example

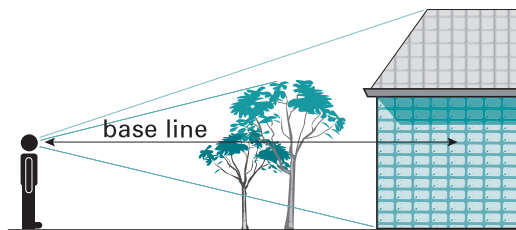

See axis, horizontal line

base ten system

See decimal place-value system, decimal system, index, index notation, multibase arithmetic blocks, power of a number

basic facts

Operations performed with one-digit numbers 0, 1, 2, 3, 4, 5, 6, 7, 8 and 9.

Examples

Addition

$$0 + 0 = 0 \quad 0 + 1 = 1$$

$$1 + 1 = 2 \quad 9 + 9 = 18$$

Subtraction corresponds with addition.

Multiplication

$$0 \times 0 = 0 \quad 0 \times 1 = 0$$

$$1 \times 1 = 1 \quad 9 \times 9 = 81$$

Division corresponds with multiplication.

(Note: It is not possible to divide by zero!)

See digit, operation, zero

battleships

A game in which two players have identical grids on which they mark 'battleships' in random positions. Each has to guess the position of the opponent's battleships by naming either:

- (i) the cells on the grid

Example

	A	B	C	D	E
1					
2					
3				▲	
4					
5					

(D,3)

or

- (ii) points of intersection of lines to pinpoint their location.

Example

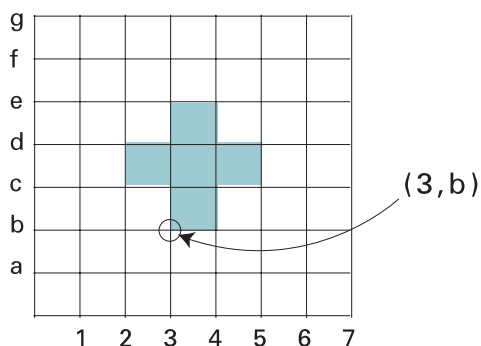

(Note: Ordered pairs are used to locate the cells or the points.)

See [coordinates](#), [grid](#), [ordered pair](#)

BC

(Before Christ)

The years before Christ was born.

Example

Egyptian Pharaoh Tutankhamen ruled in 14th-century BC.

See [BCE](#), [AD](#)

BCE

(Before the Common Era)

Indicates the same period as BC.

BCE can be used in place of BC.

See [BC](#), [AD](#)



beam balance

Any balance where a beam is used.

Examples

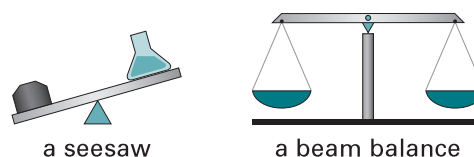

A beam balance is used to measure the mass of an object by balancing it with an object whose mass is known.

See [balance](#), [mass](#)

bearing

A horizontal angle measured from 0° to 90° between a north or south direction and the direction of the object.

True bearings are measured to the true north direction, magnetic bearings to the magnetic north (or south).

Example

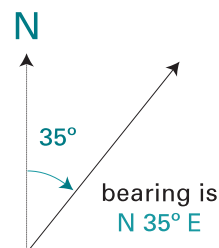

See [compass](#), [direction](#)

bi



A prefix which stands in front of words and means two or twice.

Examples

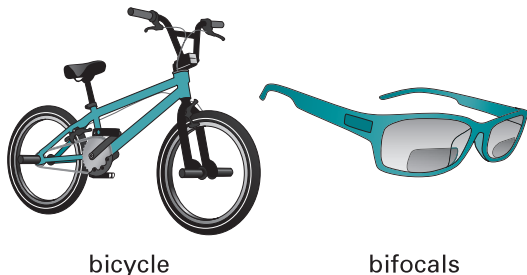

bicycle

bifocals

See binomial, bisect, bisector

bicentenary

200th anniversary.

Example

1970 marked the bicentenary of Captain Cook's landing at Botany Bay.

billion

In most English-speaking countries, including Australia, a billion means 1000 millions.

$$1\ 000\ 000\ 000 \text{ or } 10^9$$

Note: In many European countries a billion means a million millions (10^{12}).

binary

A base-2 number system that uses only 0 and 1 to represent numbers. It is the smallest number system used to represent information. All numbers can be represented in a binary system.

Example

Binary (Base-2) system

Place value	a^7	a^6	a^5	a^4	a^3	a^2	a^1	a^0	
Binary	2^7	2^6	2^5	2^4	2^3	2^2	2^1	2^0	
Value	128	64	32	16	8	4	2	1	Number
									0 0
								0	1 1
								1	0 2
							0	1	1 3
					0	1	0	0	4
				0	1	0	1	0	10
				0	1	1	1	1	15
			0	1	1	0	0	0	25
0	1	0	0	0	1	1	0	0	140

binomial

In algebra, an expression consisting of two terms joined by + or -. The terms are called monomials.

Examples

$$2 + a \quad 3a - b \quad 2x^2 + y^2$$

See algebra

bisect

To cut or divide into two equal parts.

Example

This angle has been bisected.

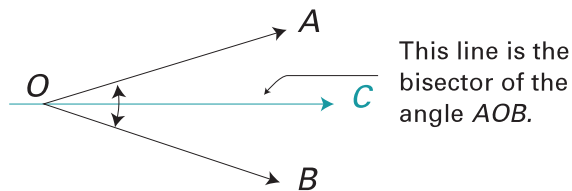

This line is the bisector of the angle AOB.

$$\angle AOC = \angle COB$$

bisector

A straight line which divides an angle, or an interval, into two equal parts.

Examples

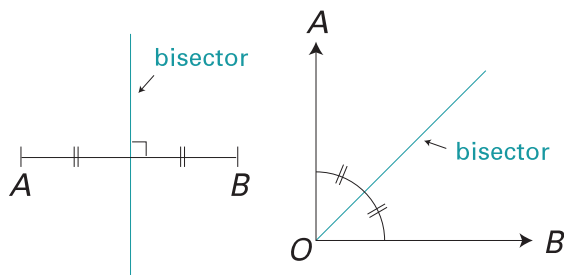

See bisect, interval, midpoint

boundary

A line around the edge of a region.

Examples

- (i) The boundary around a soccer field

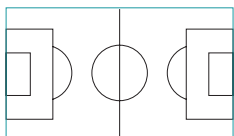

- (ii) The boundary of Queensland

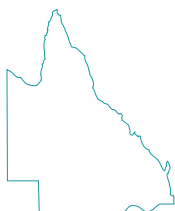

- (iii) The boundary of a hexagon is its perimeter.

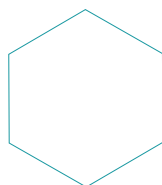

See perimeter, region

braces

- (i) Braces are used for grouping numbers together.

Example

$$\begin{aligned} \{ & \{ 3 + [12 - 3(2 + 1)] \times 2 \} \\ \text{braces} & = \{ 3 + [12 - 9] \times 2 \} \\ & = 3 + 6 \\ & = 9 \end{aligned}$$

- (ii) The sign $\{ \}$ is used to stand for the word 'set'. The elements of the set are written inside these 'curly brackets'.

Example

The set of counting numbers

$\{1, 2, 3, 4, 5, 6, 7, \dots\}$

See brackets, order of operations, parentheses

brackets

The signs $() [] \{ \}$ are used for grouping things or numbers together.

$()$	$[]$	$\{ \}$
ordinary brackets (parentheses)	square brackets	braces

Brackets are used to indicate the order of operations.

Example

$$\begin{aligned} & 5 \{ 2[4(3 + 10) - (35 \div 5) - 8] \} \\ & = 5 \{ 2[(4 \times 13) - 7 - 8] \} \quad \text{1 remove ordinary brackets} \\ & = 5 \{ 2[52 - 15] \} \quad \text{2 remove square brackets} \\ & = 5 \{ 2 \times 37 \} \quad \text{3 remove braces} \\ & = 5 \times 74 = 370 \end{aligned}$$

See braces, order of operations, parentheses



breadth



Measurement from side to side, also called width.

Example

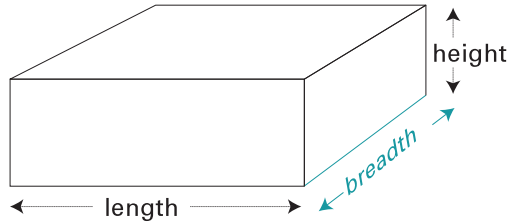

See height, length, width

budget

A plan for using money.

Example

Jessica earns \$560 a fortnight. Her budget is:

Rent and food	\$340
Bus fares	\$45
Clothes	\$50
Entertainment	\$60
Savings	\$65
<hr/> Total	<hr/> \$560



C

- (i) C is a symbol for Celsius temperature scale.
- 0 °C water freezes
- 100 °C water boils
- (ii) A symbol for circumference in formulas.

Examples

$$C = \pi d$$

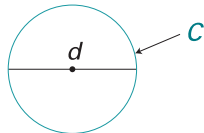

or $C = 2\pi r$

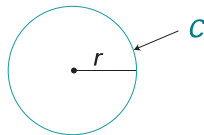

- (iii) In Roman numerals, C stands for one hundred.

Example

$$CCCXXII = 322$$

calculate

Work out the answer. Using mathematical procedures to determine a number, quantity or expression.

calculator

Calculating aid. Calculators are electronic. They are battery or solar powered.



calendar

A calendar represents the way in which a year is broken up into months, weeks and days.

Example

2007						
JANUARY						
S	M	T	W	T	F	S
	1	2	3	4	5	6
7	8	9	10	11	12	13
14	15	16	17	18	19	20
21	22	23	24	25	26	27
28	29	30	31			
FEBRUARY						
S	M	T	W	T	F	S
				1	2	3
4	5	6	7	8	9	10
11	12	13	14	15	16	17
18	19	20	21	22	23	24
25	26	27	28			

The third Thursday in February 2007 is the 15th.

See day, leap year, month, year

calliper

A measuring instrument similar to compasses with curved legs for measuring thickness (diameter) of curved (convex) objects or, turned outwards, for measuring cavities.

Example

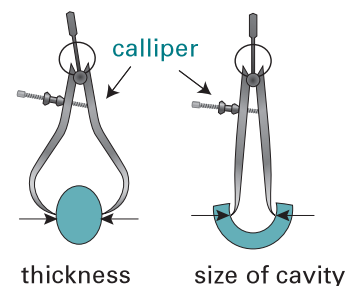

See compasses, concave, convex

cancelling

A method of changing a fraction to its simplest form.

Examples

- (i) Divide both numerator and denominator by three (common factor).

$$\frac{15 \div 3}{21 \div 3} = \frac{15 \cancel{\div 3}^5}{21 \cancel{\div 3}^7} = \frac{5}{7}$$

- (ii) Divide across.

$$\frac{3 \cancel{15}}{2 \cancel{22}} \times \frac{\cancel{33}^3}{\cancel{40}_8} = \frac{3 \times 3}{2 \times 8} = \frac{9}{16}$$

See denominator, fraction, numerator, simple fraction, simplify

capacity

How much a container can hold. The number of cubic units a container can hold is called the capacity or volume of the container. Volume is the actual amount of material in the container.

Units of capacity are:

cubic centimetre cm^3

cubic metre m^3

millilitre mL

litre L

kilolitre kL

megalitre ML

1 mL = 1 cm^3

1000 mL = 1 L = 1000 cm^3

1000 L = 1 kL = 1 m^3

Example

An eye dropper holds about 1 millilitre of liquid, which fills one cubic centimetre.

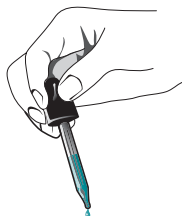

See section Metric relationships on page 149, volume

cardinal number

The number of all elements (members) in a set. When we count, we give each element one number, starting with 1. These numbers are in sequence. The last number given is the cardinal number of the set.

Example

How many balloons?

The cardinal number of this set of balloons is 5.

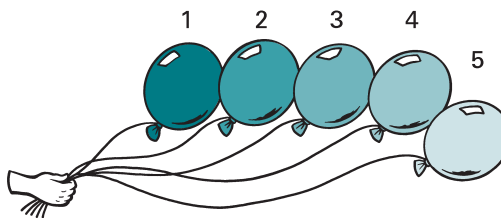

See counting, sequence, set

Carroll diagram

A method of recording a classification activity (used by Lewis Carroll).

Example

	black	not black
square		
not square		

See attribute, classify, diagram, sorting

carrying

Another word for regrouping.

Example

$$\begin{array}{r} 25 \\ + 18 \\ \hline 33 \end{array}$$

Add $5 + 8 = 13$.
Write 3 in unit column and carry 1 into tens column.

See regroup

Cartesian coordinates

See coordinates

CC

A symbol sometimes used to show cubic centimetre. The correct symbol is cm^3 .

See cubic centimetre

Celsius scale

See C, degree Celsius, temperature

CE

(Common Era)

Indicates the same period as AD.

CE can be used in place of AD.

See AD, BC

cent

(Symbol: c)

One cent is one hundredth of a dollar.

$$\begin{aligned} 1\text{c} &= \$0.01 \\ \$1 &= 100\text{c} \end{aligned}$$



One cent used to be the smallest coin in Australian currency. Now it is the five-cent coin.



See dollar

centi

A prefix meaning one hundredth.

Example

One centimetre is one hundredth of a metre.

$$1\text{ cm} = 0.01\text{ m}$$

See centimetre, decimal place-value system, length, see Decimal system prefixes on page 153

Centigrade

Old name used for a temperature scale divided into 100 degrees. We now call it the Celsius scale.

See degree Celsius, temperature

centimetre

(Symbol: cm)

A unit of length.

$$1\text{ cm} = 0.01\text{ m}$$

$$100\text{ cm} = 1\text{ m}$$

Example

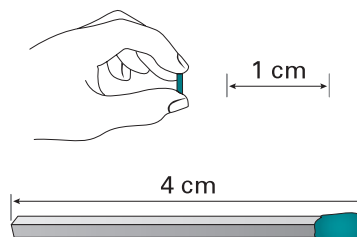

This match is 4 centimetres long.

See length, unit of measurement

centre

A point that is the same distance from all points of a circle, a sphere, etc.

Example

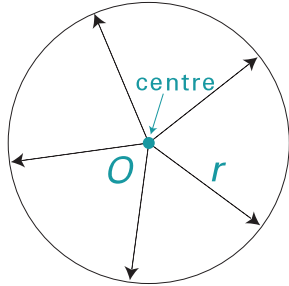

See circle, circumference, radius

century

One hundred.

Examples

100 years, 100 runs in cricket, etc.

From 1 January 1901 to 31 December 2000 is the 20th century.

The 21st century began on 1 January 2001.

chance

A likelihood of an event happening.

See probability

chance event

An event of which the outcome is uncertain.

For some events we can predict a possible outcome, but we can never be sure.

Examples

Tossing a coin, rolling a die, drawing a coloured marble from a bag

See probability

checking

A way of making sure that an answer is correct. One way of checking is by using the inverse operation.

Examples

(i) Addition is checked by subtraction.

$$\begin{array}{r} 15 \\ + 28 \\ \hline 43 \end{array} \quad \begin{array}{r} 43 \\ - 28 \\ \hline 15 \end{array}$$

The answer 43 is correct.

(ii) Division is checked by multiplication.

$$\begin{array}{r} 14 \text{ (r2)} \\ 4 \overline{) 58} \\ \underline{4} \\ 18 \\ \underline{16} \\ 2 \end{array} \quad \begin{array}{r} 14 \text{ quotient} \\ \times 4 \text{ } \times \text{ divisor} \\ \hline 56 \\ + 2 \text{ add remainder} \\ \hline 58 \text{ dividend} \end{array}$$

The answer 14 (r2) is correct.

See inverse, inverse operations

chord

A line joining two points on a circle.

Examples

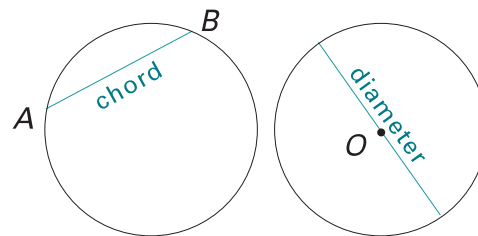

The diameter is the longest chord in a circle.

See circumference, diameter

chronological order

Events arranged by the date or time when they happened.

Example

THE HISTORY OF π

Time	Who/Where	Value of π
2000 BC	Babylonia	$3\frac{1}{8}$
300 BC	Archimedes	$3\frac{10}{71}$ to $3\frac{1}{7}$
1220 AD	Fibonacci	3.141 818
1665	Newton	3.141 592 653 589 7932
1705		π sign was first used
1949	ENIAC computer	π correct to 2035 decimal places
1984	Tokyo	π computed to 16 million decimal places

See pi, time line

circle

The set of all points in a plane which are at the same distance (radius r) from a given point O (centre).

Example

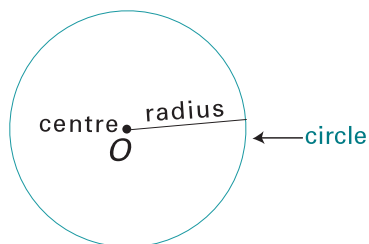

See centre, circumference, diameter, plane, radius

circle graph

See pie graph

circular

In the form of a circle; round.

Example

A merry-go-round is circular.



See circle

circumference

The perimeter of a circle. The distance around a circle.

If the radius is r units, then the circumference C is $2\pi r$ units.

Example

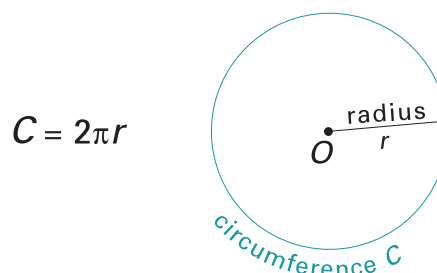

When the diameter d is measured, then the circumference C is πd units.

Example

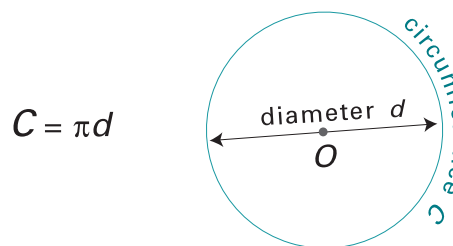

See circle, diameter, perimeter, pi

class

A group, set, or collection of things.

Example

Triangles, squares, rectangles and kites belong to the class of polygons.

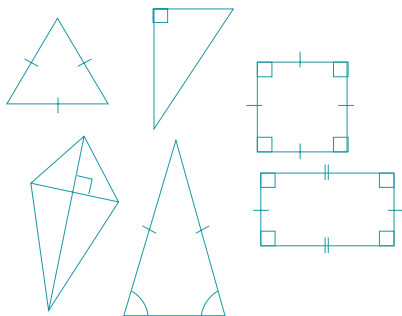

See classification, classify

classification

Arrangement into classes, sets or groups, according to attributes.

Examples

	not green	green
not		

Have pets	Don't have pets
Quong	Halima
Kelly	Nick
Grant	Dean
Toula	Anna
Ali	Scott
Claire	Sachiko

See attribute, property

classify

Sort objects, ideas or events into groups, classes or hierarchies according to one or more properties or attributes.

See attribute, property, sorting

clockwise

The direction in which the hands of a clock normally travel.

Example

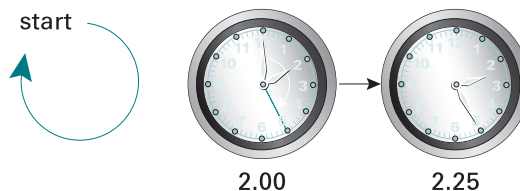

The hands on this clock have moved in a clockwise direction.

Screws and bottle tops are tightened clockwise.

See anticlockwise

closed curve

A curve which starts at a point and comes back to that point.

Examples

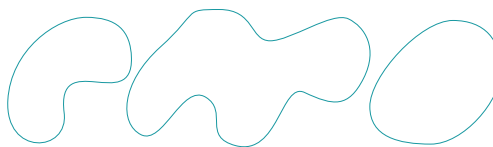

(i) Simple closed curves

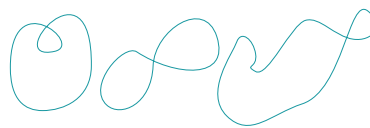

(ii) Closed curves that are not simple



(iii) Regular closed curves

See circle, curve, ellipse, open curve

closed shape

A shape (polygon) whose sides begin and end at the same point.

Examples

closed shapes

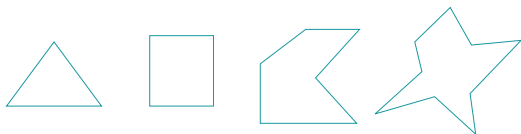

These are not closed shapes.

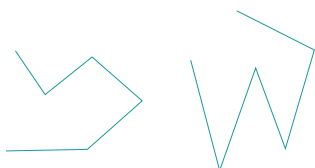

See polygon, shape

cm

The symbol for centimetre.

See centimetre, symbol

code

A system of words, letters or symbols which represent other letters, words or sentences. Codes are used for secret writing or signalling.

Example

Morse code
M O T H E R



coefficient

The number (constant term) in front of a pronumeral (variable) in an algebraic term.

Examples

$3y$ 3 is the coefficient of y

$7(a + b)$ 7 is the coefficient
of $(a + b)$

xy coefficient is 1

See algebra, pronumeral

cointerior angles

See parallel lines

collinear

Three or more points that lie on the same straight line.

Example

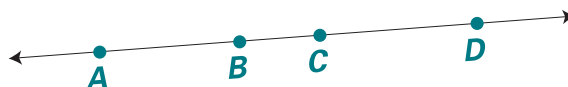

A, B, C and D are collinear points.

See line, point

column

A vertical arrangement.

Examples

13

5

18

27

9

column of numbers



column of cars

See column graph

column graph

A graph that uses columns of different lengths to represent various kinds of information.



Example

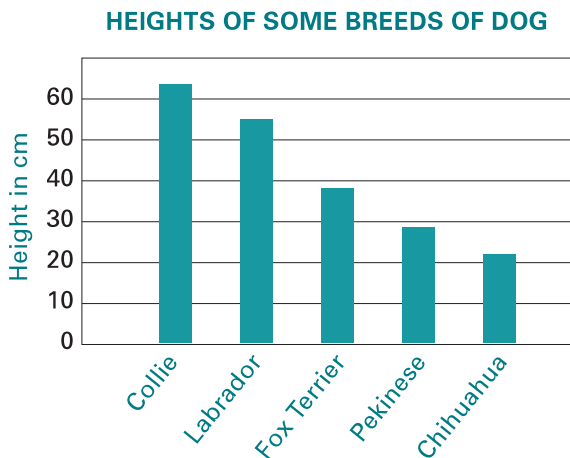

See bar graph, column

combination

A way of arranging the objects in a group.

Example

There are four shapes in this group.



The possible pairings are:

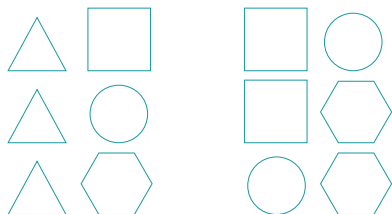

Each pairing is called a combination.

The order in which the shapes are placed is not important.

See permutation, set, subset

combined shapes

(complex)

Plane shapes that are made of two or more polygons.

Example

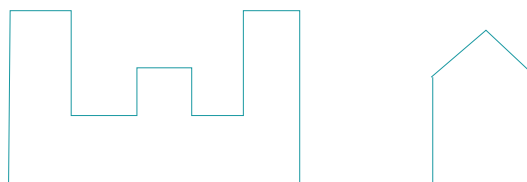

To calculate the area of a combined shape, divide it into simple shapes. Find the area of each shape, then add those to find the area of the combined shape.

Example

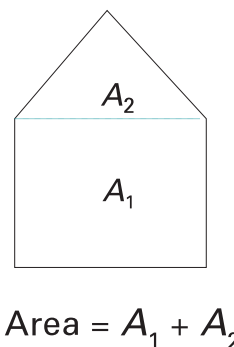

commission

A commission is a fee or percentage of sales paid to a sales person.

Example

A car sales person receives \$500 for every new car sold. The sales person receives a commission of \$500.

common denominator

For two or more fractions, a common denominator is a number into which all the denominators divide exactly.

Example

For the fractions $\frac{1}{2}$ and $\frac{1}{3}$ a common denominator is 6, and also 12, 18, 24, etc.

6 is the lowest common denominator (LCD).

See denominator, fraction, lowest common denominator

common fraction

See simple fraction

commutative property of addition

The order in which two or more numbers are added does not affect the answer (sum).

Example

$$\begin{aligned} 6 + 4 &= 4 + 6 \\ 10 &= 10 \end{aligned}$$

See associative property of addition, sum

commutative property of multiplication

The order in which two or more numbers are multiplied does not affect the answer (product).

Example

$$\begin{aligned} 3 \times 8 &= 8 \times 3 \\ 24 &= 24 \end{aligned}$$

See associative property of multiplication, product

comparison

Identifying whether objects, measures or quantities are the same or different.

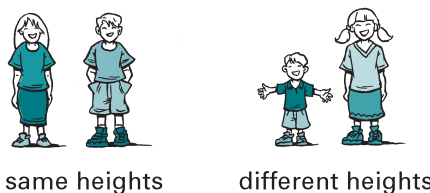
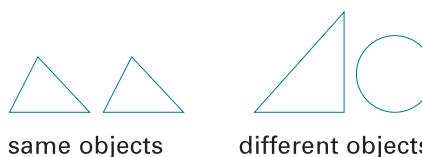
Examples

See division, ratio

compass

An instrument which shows direction. Used in ships, aeroplanes, etc.

Example

See bearing, direction

compasses

(pair of)

An instrument used to draw a circle and to mark off equal lengths. Often called a compass, for short.

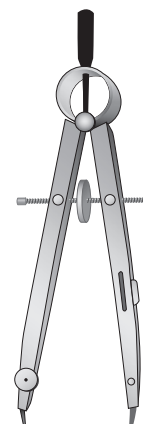

complement

Something that completes or fills up a whole.

See complementary addition, complementary angles



complementary addition

(i) Finding the amount to complete a set.

Example

What has to be added to seven to make ten?

$$7 + \square = 10$$

$$7 + 3 = 10$$

Answer: Three has to be added.

(ii) Counting on to a higher total (as change is given after a purchase).

Example

Shopping costs \$17.50. I pay with a \$20 note. I get \$2.50 change. This is evaluated by finding what must be added to \$17.50 to make \$20.

(iii) The method of 'subtracting' which converts the subtraction question to an addition question.

Example

$$21 - 19 = 2$$

Instead of taking nineteen away from twenty-one we think how much must be added to nineteen to make twenty-one.

See addition, set, subtraction

complementary angles

Two angles that together measure 90° .

Example

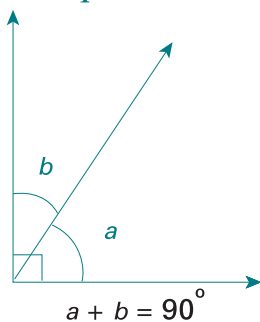

$\angle a$ and $\angle b$ are complementary.

$\angle a$ is the complement of $\angle b$.

$\angle b$ is the complement of $\angle a$.

See supplementary angles

complex fraction

A fraction whose numerator, denominator, or both, are fractions.

Examples

$$\frac{\frac{1}{2}}{5} \quad \frac{3}{\frac{4}{7}} \quad \frac{\frac{1}{2}}{\frac{3}{4}} \quad \frac{\frac{a}{b}}{\frac{c}{d}}$$

Note: To simplify a complex fraction means the same as division of fractions. It can be done in two ways.

Example

Divide $\frac{1}{2}$ by $\frac{2}{3}$.

$$1 \quad \frac{1}{2} \div \frac{2}{3} = \frac{1}{2} \times \frac{3}{2} = \frac{3}{4}$$

$$2 \quad \frac{\frac{1}{2}}{\frac{2}{3}} = \frac{1 \times 3}{2 \times 2} = \frac{3}{4}$$

composite number

A number with factors other than itself and one.

Examples

$$12 = 12 \times 1 = 3 \times 4 = 3 \times 2 \times 2$$

$$33 = 33 \times 1 = 3 \times 11$$

Both twelve and thirty-three are composite numbers.

$$17 = 17 \times 1 \quad 23 = 23 \times 1$$

Seventeen and twenty-three are not composite numbers.

Numbers which have no other factors except themselves and one, such as seventeen, are called prime numbers.

Every whole number greater than one is either:

(i) a prime number
(2, 3, 5, 7, 11 ...)

or

(ii) a composite number
(4, 6, 8, 9, 10, 12, 14 ...).

See factors, prime number

compound operation

See order of operations

computation

Using addition, subtraction, multiplication and/or division to find the answer. These operations can be performed mentally, in writing or with the help of calculating aids such as an abacus, tables, calculators or computers.

See abacus, calculator, table

compute

To work out or calculate.

Example

$$\begin{array}{r} 14.7 \\ \times 23.21 \\ \hline 47 \\ 940 \\ 14100 \\ 15087 \end{array}$$

concave

A shape that is hollowed or rounded inward like the inside of a bowl.

Examples

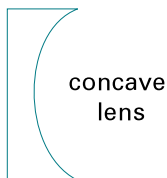
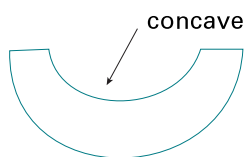

See convex

concentric circles

Circles that are in the same plane and have the same centre are concentric.

Example

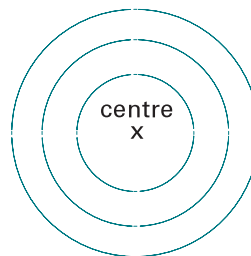

See annulus, circle, plane

concurrent lines

Lines that intersect at the same point.

Example

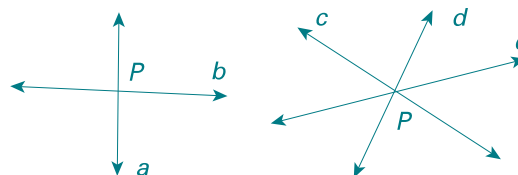

See intersect, parallel lines

cone

A solid which has a circular base and comes to a point at the top, similar in shape to an ice-cream cone.

Examples

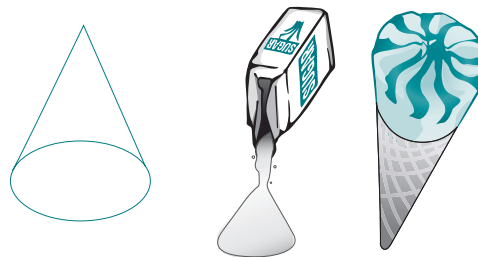

See right 3D shape, solid



congruent

(Symbol: \equiv)

Exactly equal. Matching exactly. Two figures are congruent if they have the same shape and the same size.



Examples

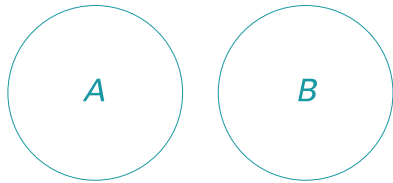

Circle A is congruent to circle B.

$$A \equiv B$$

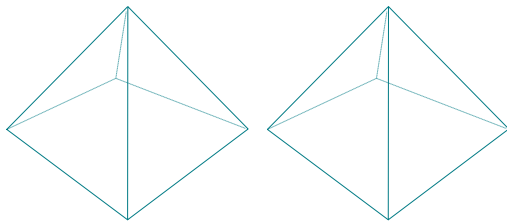

congruent pyramids

See corresponding angles, similar

conic section

A figure (circle, ellipse or parabola) formed when a right circular cone is cut by a plane.

Example

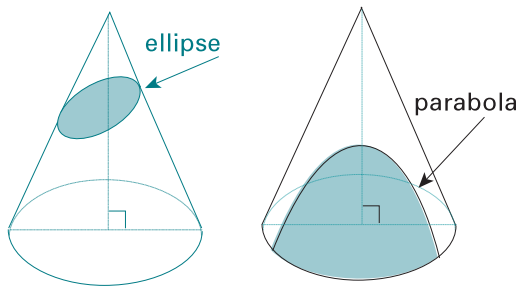

See circle, ellipse, parabola

consecutive numbers

Numbers that follow each other in a sequence.

Examples

1 2 3 4 5 6 7 8

$\frac{1}{7}$ $\frac{2}{7}$ $\frac{3}{7}$ $\frac{4}{7}$ $\frac{5}{7}$ $\frac{6}{7}$

0.1 0.2 0.3 0.4

See sequence

conservation of area

Retaining the same area.

Examples

(i) The three triangles have the same area.

$A = \frac{1}{2} \times 2 \text{ cm} \times 2.5 \text{ cm} = 2.5 \text{ cm}^2$, even though their shapes are different.

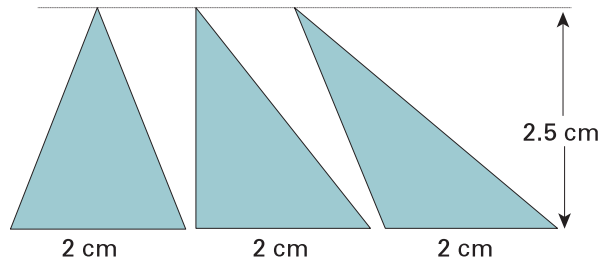

(ii) The three shapes have the same area of 3 cm^2 .

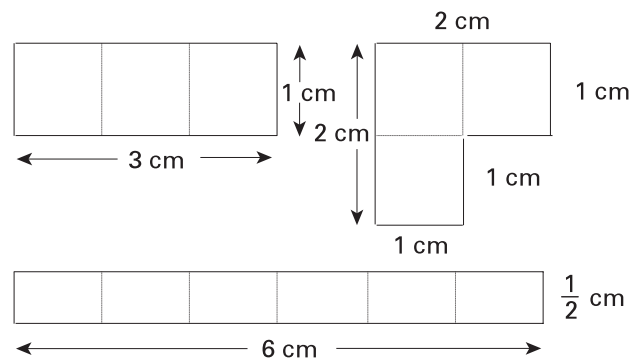

See area

constant

A number that always has the same value, unlike a variable.

Example

$$2c + 6$$

6 is the constant.

See variable

continuous data

Data that consist of measurements that can take on any decimal value along a continuous scale.

Example

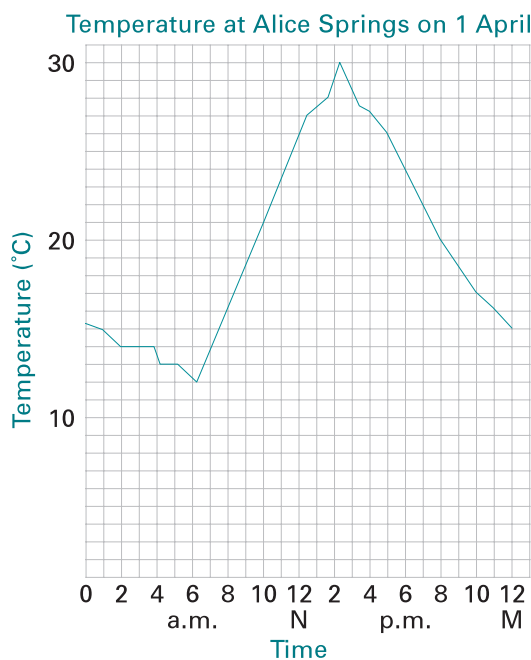

Other examples are mass and distance.

See data, discrete data

converging lines

Two or more lines that meet at the same point.

Example

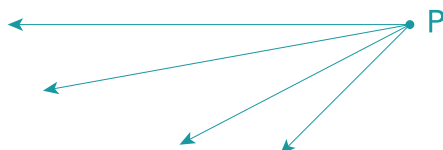

See perspective

convex

Shaped like the outside of a circle or a sphere. The opposite of concave.

Example

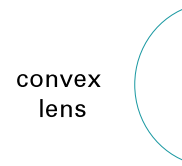

See concave

coordinates

A pair of numbers or letters that show the position of a point on the plane. The first number is always the x -coordinate, the second is the y -coordinate.

Examples

- (i) Each point on the plane is given an ordered pair of numbers, written in parentheses.

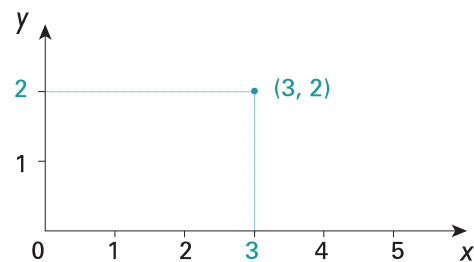

Point (3, 2) has the x -coordinate 3, and the y -coordinate 2.

- (ii) The position of Judith Avenue is B3.

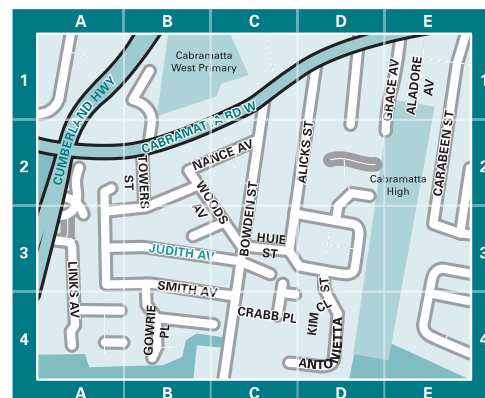

See axis, intersection, ordered pair, origin



coplanar

Lying or being in the same plane.

Example

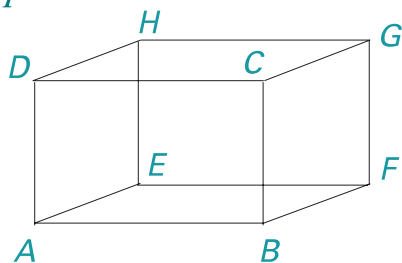

C , D , G and H are coplanar points.

AB and CG are not coplanar.

correspondence

See many-to-one correspondence, one-to-one correspondence

corresponding angles

Angles in the same or similar position. In congruent shapes, corresponding angles have the same size (are congruent).

Example

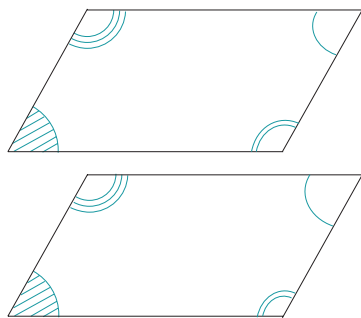

These parallelograms are congruent. Corresponding angles are marked by the same symbol.

See congruent, parallel lines, vertically opposite angles

corresponding sides

In congruent shapes, like the triangles below, the sides AB and XY , BC and YZ , and CA and ZX are corresponding sides.

Example

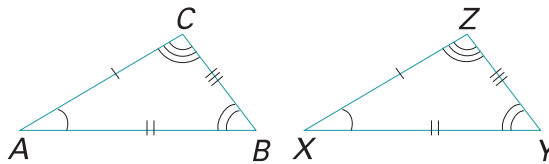

See congruent

cost price

Price at which something is produced or bought.

Example

A car dealer buys a car for \$10 000. The cost price of the car is \$10 000.

See selling price

counting

Giving one number to every item in a set. These numbers are in a sequence.

Example



The numbers 1, 2, 3, 4, 5 ... are counting numbers.

See cardinal number, sequence, set

counting number

A member of the set of numbers used in counting: $\{1, 2, 3, 4 \dots\}$.

Note: zero is not a counting number.

See cardinal number, number

counting system

A way of finding out how many objects there are.

See decimal place-value system

cross-section of a solid

The face that is made when a solid is cut through by a plane.

Example

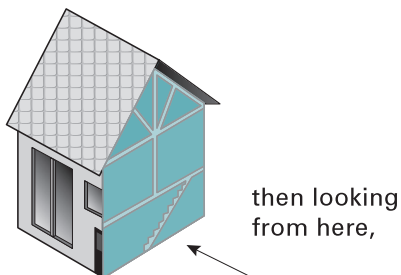
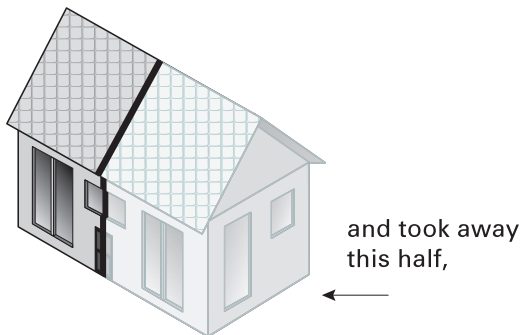
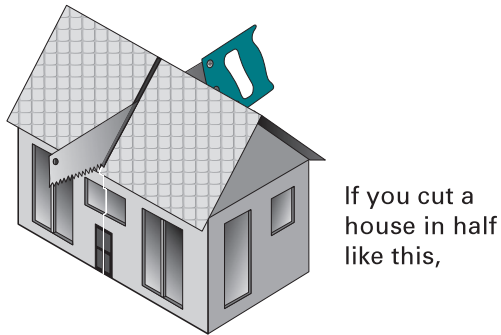

See face, front view, plan, plane, section, side view

cube

A solid, shaped like a box, with twelve equal edges, six equal square faces and eight corners. A cube is a type of cuboid.

Examples

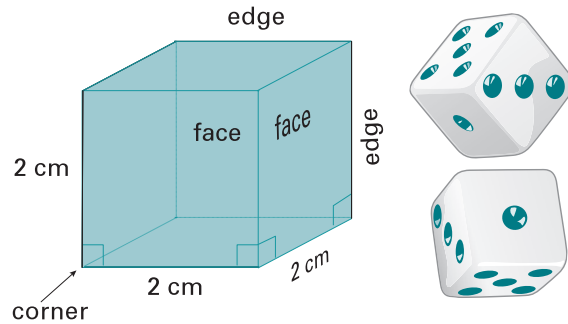

This is a diagram of a 2 cm cube.

See cuboid, face, hexahedron, solid

cubed number

4^3 ← index
↑
base

4^3 means $4 \times 4 \times 4$ or 64.

We read it as '4 cubed', '4 cube' or '4 to the third power'.

See index, index notation, power of a number, square number

cubic centimetre

(Symbol: cm^3)

A cubic centimetre is a unit for measuring volume.

Example

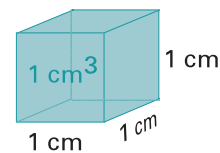

It is a cube with edges of 1 cm.

1 cm^3 has a capacity of 1 millilitre.

See capacity, cube, unit of measurement, volume

cubic metre

(Symbol: m³)

A cubic metre is a unit for measuring volume.

Example

A cube whose edges are 1 metre long has a volume of 1 cubic metre.

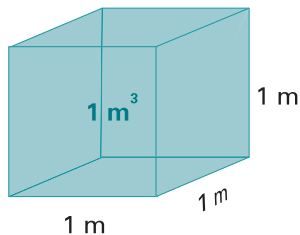

$1 \text{ m}^3 = 1\,000\,000 \text{ cm}^3$

1 m³ has a capacity of 1 kilolitre.

See capacity, unit of measurement, volume

cubic unit

A measure of volume.

See cubic centimetre, cubic metre, volume

cuboid

A shape such as a shoe box. A cube-like prism. It has twelve edges, six faces and eight corners. The opposite faces are the same shape and size.

Examples



These packets are cuboids.

See cube, face, hexahedron, prism

curve

A line of which no part is straight. There are open curves and closed curves.

Examples

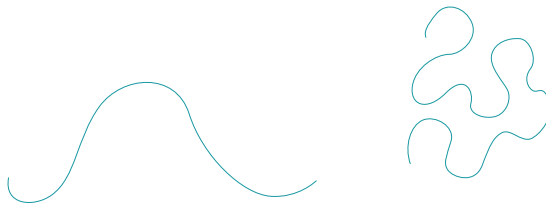

open curves

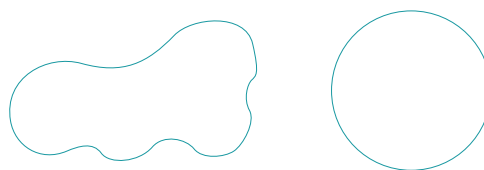

closed curves

See closed curve, open curve

cycle

A system that repeats itself in time.

Example

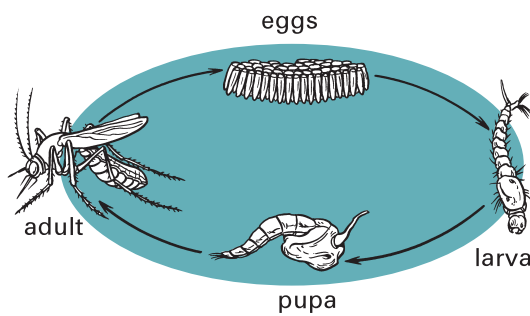

The breeding cycle of mosquitoes

cycle game

A game that follows a set of rules in which the last move returns the player to the starting point.

Examples

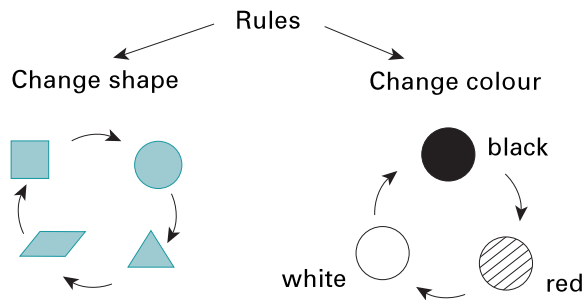

See rule

cylinder

A cylinder is a shape like a can. It is a solid with two circular faces at right angles to a curved surface.

Examples



See capacity, right 3D shape





data

A general term used to describe a collection of facts, numbers, measurements or symbols.

Example

Students' scores in a maths test were 15, 16, 18, 19, 19, 20, 21, 21, 22 marks.

date

Specified time: day, month or year, at which something takes place.

Example

The date on my letter is 10 May 1998.

day

The 24-hour period it takes the Earth to turn once on its axis.

days of the week

Weekdays are: Monday, Tuesday, Wednesday, Thursday and Friday.

Weekend days are: Saturday and Sunday.

deca

Prefix that means 10.

See decade, decagon, decahedron

decade

Ten years.

decagon

A polygon with ten sides.

Example

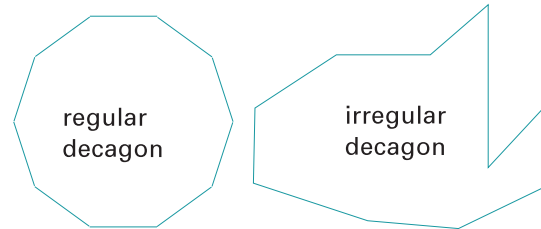

See polygon

decahedron

A polyhedron with ten faces.

Example

This decahedron has been made by joining two pyramids and cutting their tops off.

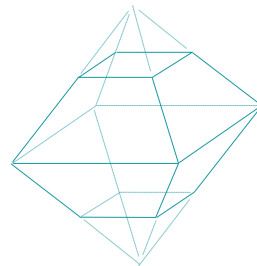

See frustum, polyhedron

decimal

Containing ten parts.

decimal fraction

A fraction written as a decimal.

Example

$$\frac{1}{10} = 0.1$$

simple fraction
decimal fraction

See decimal place-value system

decimal place-value system

A numeration system with ten as a base for grouping. Commonly called the 'base ten' system.

10^6	10^5	10^4	10^3	10^2	10^1	10^0	10^{-1}	10^{-2}	10^{-3}
millions	hundred thousands	ten thousands	thousands	hundreds	tens	units	tenths	hundredths	thousandths

See base, decimal point, place value

decimal point

A point or comma (used in Europe) that separates a decimal fraction from the whole number.

Example

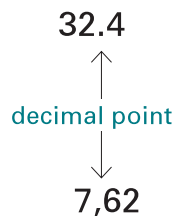

See point

decimal system

See decimal place-value system

declination

The slope indicating where an object is compared to a vertical or horizontal position.

Example

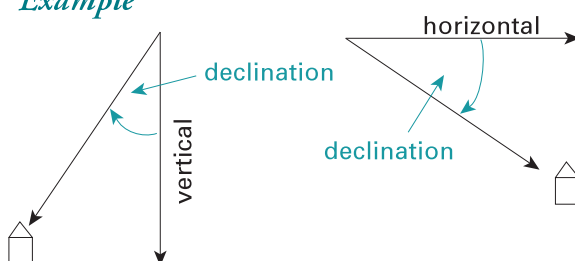

decrease

Make smaller. We either subtract a number or divide by a number.

Examples

- (i) Decrease this length by 2 cm.

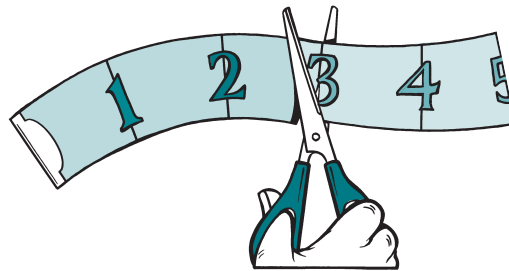

$$5 \text{ cm} - 2 \text{ cm} = 3 \text{ cm}$$

We decreased 5 cm to 3 cm by cutting 2 cm off.

- (ii) Decrease \$100 five times.

$$\$100 \div 5 = \$20$$

\$100 decreased five times is \$20.

See increase, progression

degree

(Symbol: $^{\circ}$)

- (i) In geometry, a degree is a unit for measuring angles.

Examples

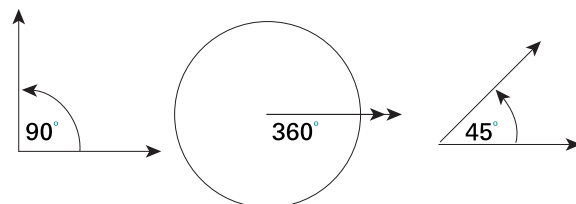

1 degree is divided into 60 minutes

$$1^{\circ} (\text{degree}) = 60' (\text{minutes})$$

1 minute is divided into 60 seconds

$$1' (\text{minute}) = 60'' (\text{seconds})$$

(Don't confuse these with the symbols for feet and inches.)

- (ii) The unit for measuring temperature.

See angle, degree Celsius, geometry, temperature, unit of measurement

diagram

A name given to pictures or sketches of geometric figures. It is also used for simplified drawings which explain or describe other things.

Examples

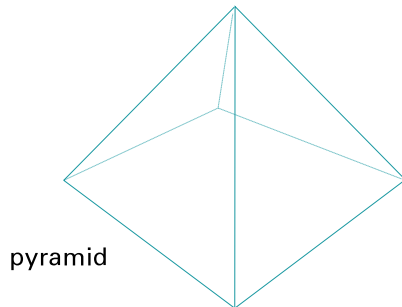

THE WATER CYCLE

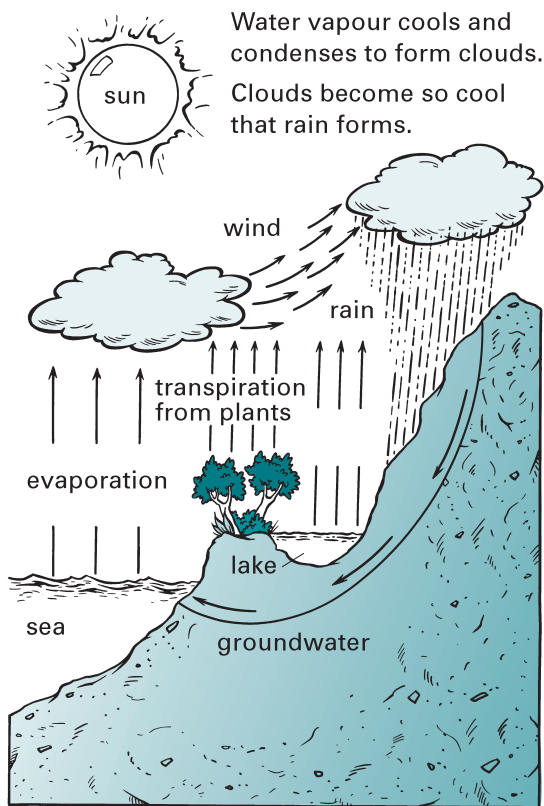

Water flows back into the sea, lakes and rivers.

See Carroll diagram

diameter

A line segment joining two points of a circle and passing through the centre of the circle. Diameter equals two radii (r).

Example

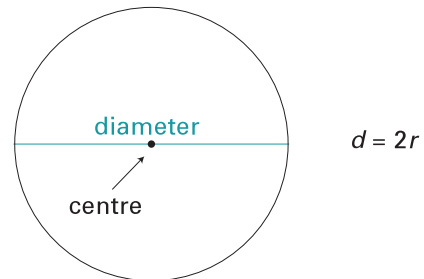

See chord, circle, circumference, line segment, radius

diamond

A two-dimensional shape with four equal sides where the angles are not right angles.

The correct name is rhombus.

Examples

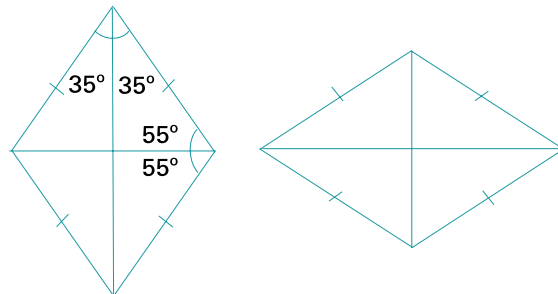

See dimension, rhombus

die

(Plural: dice)

A regular polyhedron, usually a cube, marked with a certain number of spots or numerals. Used in number games.

Examples



one die



two dice

Some dice have more than 6 faces.

difference

The amount by which two numbers differ.

Example

$$\begin{array}{c}
 10 - 3 = 7 \\
 \uparrow \quad \uparrow \quad \uparrow \\
 \text{minuend} \quad \text{subtrahend} \quad \text{difference}
 \end{array}$$

The difference between ten and three is seven.

See minuend, subtract, subtraction, subtrahend

digit

Numerals 0, 1, 2, 3, ... 9 are called digits; we can also call them one-digit numbers.

Examples

4 is a one-digit number.

56 is a two-digit number.

813 is a three-digit number.

See place holder, place value

digital clock

A clock or a watch that shows time by numbers. It has no clock hands.

Example



This clock shows twenty to ten.

See a.m., analogue clock, p.m., time interval

dimension

A property that can be measured, related to plane and space.

(i) One-dimensional (1D) objects have only length.

Examples

lines, curves

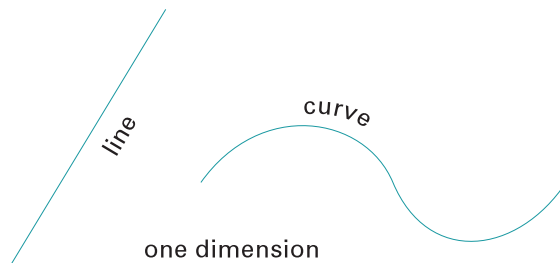

(ii) Two-dimensional (2D) objects have length and width.

Examples

plane figures—polygons, circles

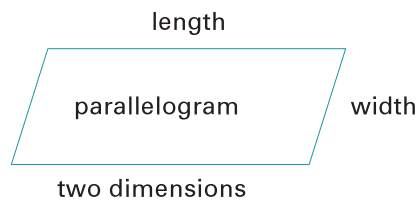

(iii) Three-dimensional (3D) objects have length, width and height.

Examples

solids—cubes, pyramids

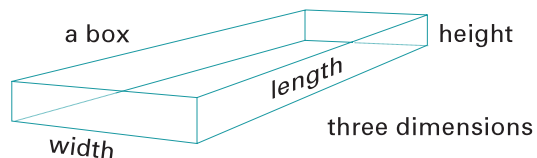

Note: A point (dot) has no dimensions.

See one-dimensional, plane, space, three-dimensional, two-dimensional

direct proportion

See proportion

directed angle

The amount of turning from one ray (or arm of an angle) to the next, used in taking bearings.

Example

The directed angle (bearing) is N 40° E.

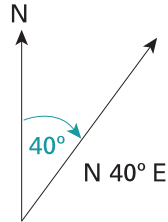

See arm of an angle, bearing, ray

directed numbers

Numbers that have + or – signs on them. They are also called integers. We can show them on a number line or axes.

Example

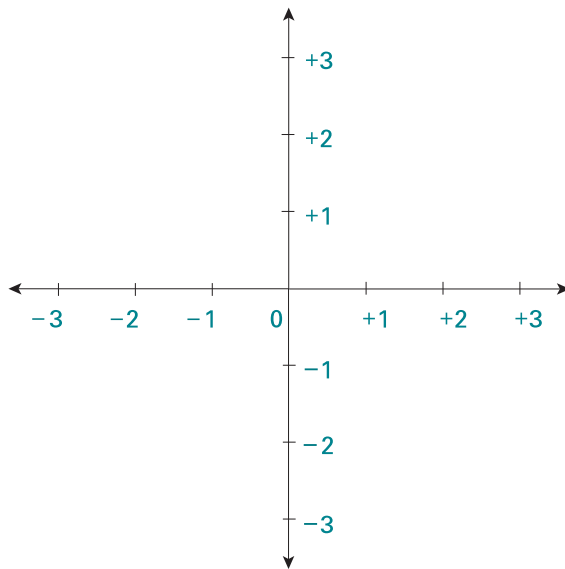

See integers

direction

(i) The way to go.

Examples

Left, right, up, down, above, below, inside, outside, near, from behind, forwards, backwards, etc.

(ii) Compass directions.

north (N)
east (E)
south (S)
west (W)
north-east (NE)
south-east (SE)
south-west (SW)
north-west (NW)



See anticlockwise, clockwise, compass

discount

If the price of something is reduced, it is sold at a discount.

Note: Discounts are often offered as a percentage of the selling price.

Example

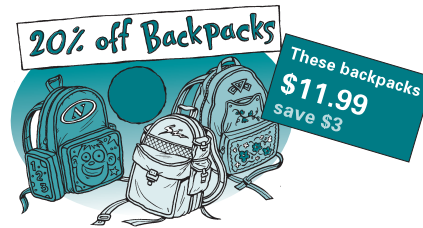

discrete data

A set of data that can be counted. They are exact.

Example

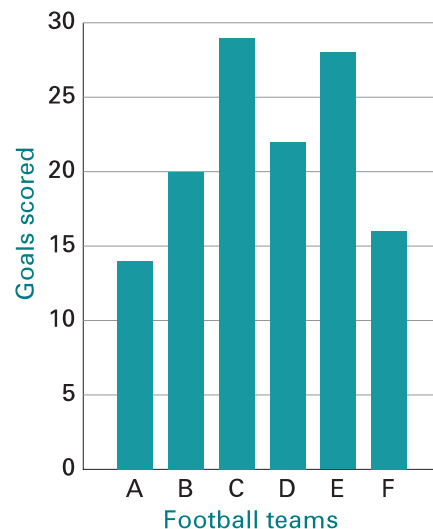

See continuous data, data

displacement

A change in the position of an object or of a quantity of material.

Example

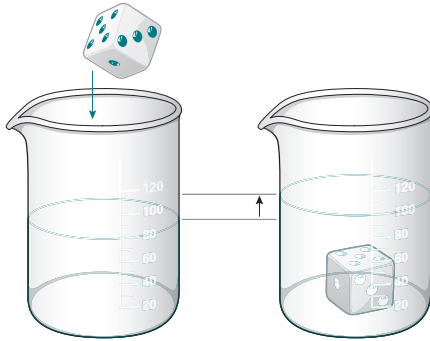

The quantity of water displaced by an immersed object

The water displacement method is used to measure the volume of objects. The volume of displaced water is equal to the volume of the object.

See volume

distance

The length between one point and another.

Example

Distance between the points of the compasses is 5 centimetres.

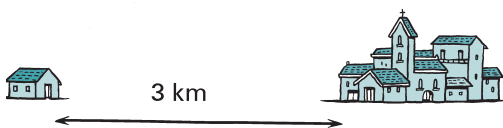
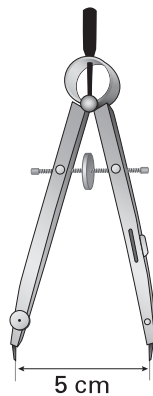

Distance from my house to town is 3 kilometres.

distribute

Give share of something to each; deal out as in division.

Example



Mum is going to distribute the cakes.

See division

distribution

See frequency distribution

distributive law

$$a(b \pm c) = ab \pm ac$$

Every term inside the grouping symbols is multiplied by the term that is immediately outside. This is also called expanding the expression or removing the grouping symbols.

See brackets, expand, expanded notation

dividend

A number which is to be divided by another number.

Example

$$\begin{array}{ccccccc}
 24 & \div & 6 & = & 4 & & \\
 \uparrow & & \uparrow & & \uparrow & & \\
 \text{dividend} & & \text{divisor} & & \text{quotient} & &
 \end{array}$$

24 is the dividend.

See divisor, quotient

divisibility tests

A number is divisible by another if, after dividing, there is no remainder.

A number is ...

divisible by	if	Examples
2	the last digit is even	2, 4, 6, ... 122 ... 358 ... 1000
3	the sum of all digits can be divided by 3	261: $2 + 6 + 1 = 9$ 3672: $3 + 6 + 7 + 2 = 18$ 18: $1 + 8 = 9$
4	the last two digits are divisible by 4	1024: $24 \div 4 = 6$
5	the last digit is 5 or 0	15, 70 ...
6	the last digit is even and the sum of its digits is divisible by 3	7446: $7 + 4 + 4 + 6 = 21$
7	there is no divisibility test	
8	the last 3 digits are divisible by 8	75384: $384 \div 8 = 48$
9	the sum of its digits is divisible by 9	3123: $3 + 1 + 2 + 3 = 9$
10	the number ends in 0	10, 20, 30 ...

Important: No number can be divided by 0.

See factors, remainder

divisible

A number is divisible by another number if, after dividing, there is no remainder.

Example

$$72 \div 9 = 8 \quad 72 \div 8 = 9$$

Seventy-two is divisible by nine and also by eight.

Nine and eight are factors of seventy-two.

See factors, remainder

division

Division is a mathematical operation which can be interpreted in several different ways:

(i) Grouping (quotition).

Example

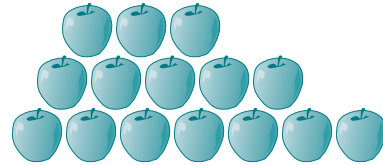

How many groups of 3 can be made with 15 apples?

The apples are to be placed into groups of equal size, 3 to a group. The problem is to find out how many groups there will be.

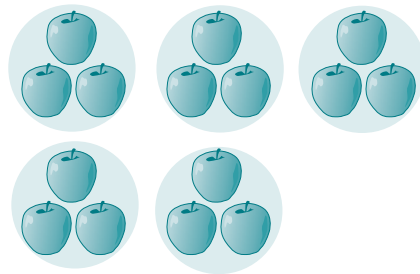

$$15 \div 3 = 5$$

There are 5 groups of 3 apples.

Repeated subtraction is a form of grouping.

▼ **division continued...**





(ii) Sharing (partition).

Example

Share 15 apples among 5 children. How many apples will each child get?



The apples are to be separated into 5 equal groups. The problem is to find how many there will be in each group.



$$15 \div 5 = 3$$

(iii) Ratio.

Comparison between two quantities.

Example

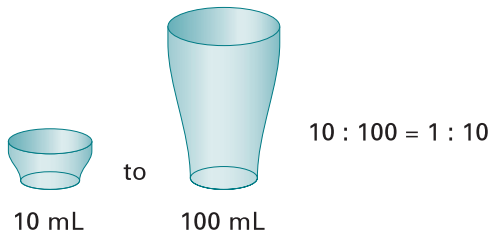

Ratio 1 : 10

Mixing 1 part of cordial and 10 parts of water to make a drink.

See ratio

divisor

A number which is to be divided into another number.

Example

$$\begin{array}{ccccccc} 24 & \div & 6 & = & 4 & & \\ \uparrow & & \uparrow & & \uparrow & & \\ \text{dividend} & & \text{divisor} & & \text{quotient} & & \end{array}$$

6 is the divisor.

See dividend, quotient

dodecagon

A polygon with twelve sides.

Examples

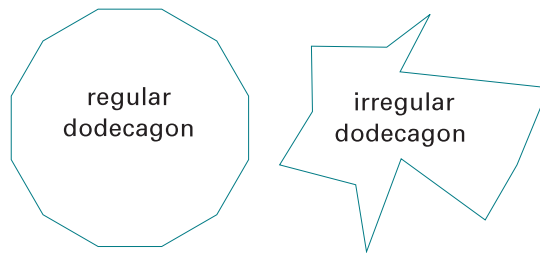

See polygon

dodecahedron

A solid (polyhedron) with twelve faces.

A regular dodecahedron is made by joining together twelve congruent regular pentagons.

Example

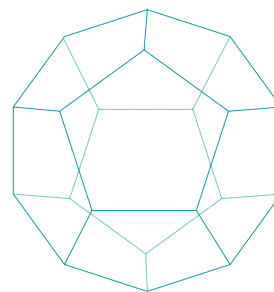

regular dodecahedron

See pentagon, polyhedron, regular polyhedron

dollar

(Symbol: \$)

A unit of money, worth 100 cents.



See cent

dot paper

Paper printed with dots arranged in a pattern. It is used for drawing shapes, defining areas, games, etc., and to record work done on a geo-board.

Examples

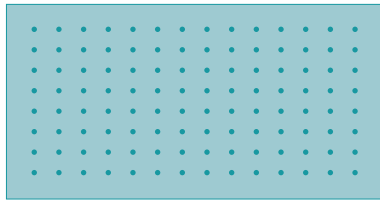

square dot paper

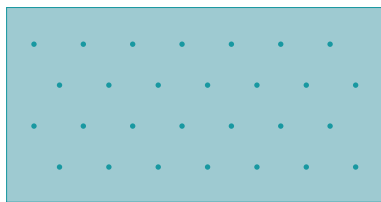

isometric dot paper

See geo-board, isometric paper, square paper

double

Twice as many, or the same again.

Examples



Double 8 is 16.

10 is double 5.

dozen

Twelve items.

Example

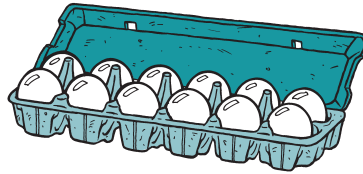

one dozen eggs = twelve eggs

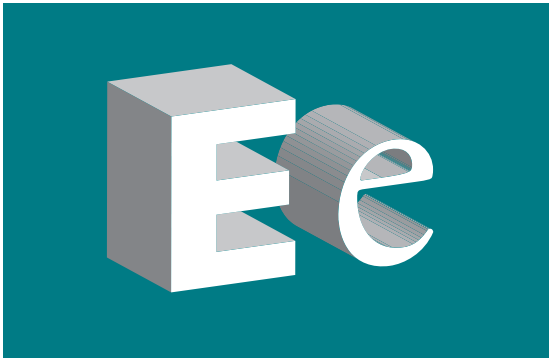

elevation, angle of

See angle of elevation

ellipse

A closed curve that looks like an elongated circle.

Examples

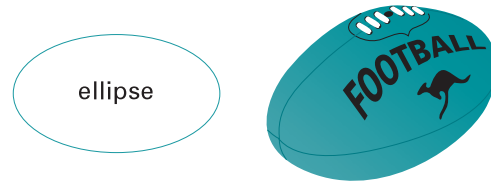

A football is elliptical in shape.

See closed curve, parabola

edge

In geometry, the line that is the intersection of two plane faces.

Examples

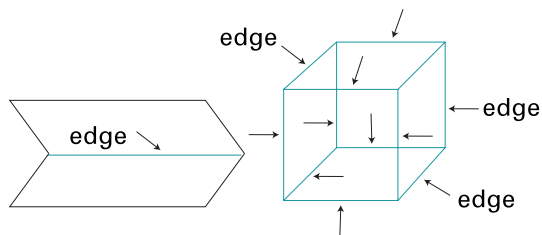

See face, intersection, plane

element of a set

One of the individual objects that belong in (are members of) a set.

Example

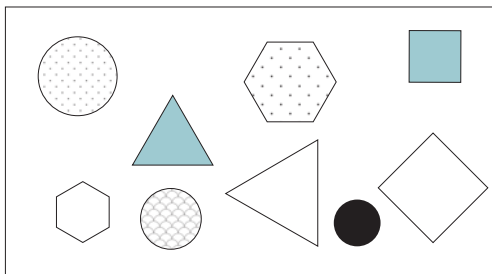

is an element of the set of shapes above.

See cardinal number, set

enlargement

Making bigger. Enlargement is the most commonly used transformation. It can be made in many ways: using a grid, rays, by pantograph or a photocopier.

Example

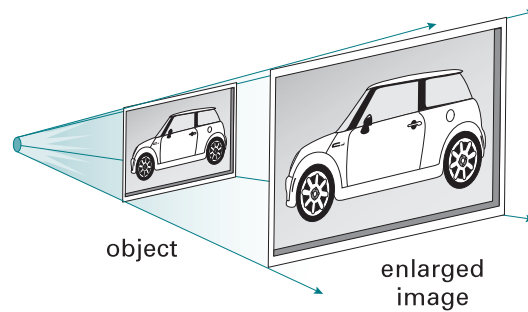

Rays were used to enlarge the picture.

See pantograph, reduce, scale drawing, transformation

equal

(Symbol: =)

- (i) Identical in quantity.

Example

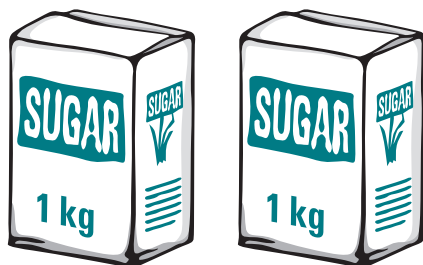

These two packets of sugar have an equal mass of one kilogram.

- (ii) Of the same value.

Examples



\$5 note equals five \$1 coins

- (iii) The sums $1 + 8 = 3 + 6 =$
 $10 - 1 = 2 + 7 =$
 $4 + 5 = 9 + 0$

are equal because they are all different ways of representing number 9.

See equality, equal sign

equaliser

A balance with numbered hooks placed at intervals along the beam so that number facts can be represented, and equality indicated, by balance.

Example

A unit mass on the fifth hook on one side would balance unit masses on the second and third hooks on the other side.

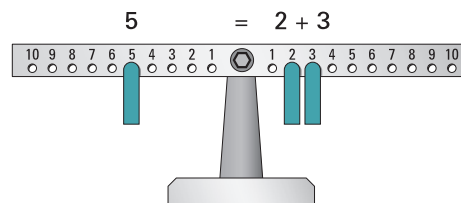

See balance, equality

equality

The relation of being equal.

A statement that two expressions are equal, usually expressed as an equation.

Example

$$2 + 4 = 6$$

See equal, equation, inequality

equally likely

Events which have the same chance of occurring are said to be equally likely.

Example

When a die is rolled fairly, the six numbers, 1, 2, 3, 4, 5 and 6, are equally likely to occur.

See chance event, probability

equal sign

(Symbol: =)

The name of the symbol which means 'is equal to' or 'equals'.

It shows that:

$$\begin{array}{ccccccc} 3 & + & 5 & = & 8 \\ \uparrow & & \uparrow & & \uparrow \\ \text{this} & & & & \text{this} \\ & & & & \text{is equal to} \end{array}$$

See equal, symbol

equation

A statement that two quantities are equal.
An equation has two sides which are equal or balanced. There must be the equal sign.

Example

$$x + 4 = 7$$

This equation is true only if x has the value of three.

The x and any other signs or letters used in equations to stand for a quantity are called place holders, pronumerals, or variables.

See equality, inequality, place holder, pronumeral, variable

equidistant

The same distance apart at every point.

Example

The distance between parallel lines is equal (the same) at every point.

See parallel lines

equilateral

Having sides of equal length.

Square, regular pentagon, hexagon and other regular polygons have sides of equal length and angles of equal size.

Examples

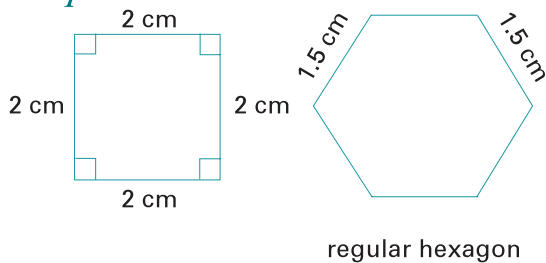

See equilateral triangle

equilateral triangle

A triangle that has three sides of equal length and three equal angles.

Examples

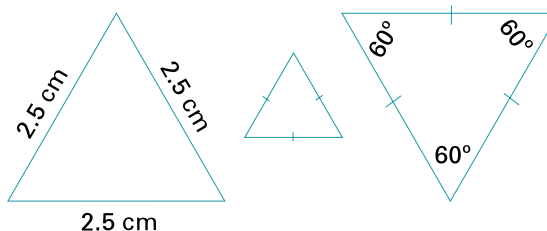

The angles of any equilateral triangle are always 60° .

See equilateral, triangle

equivalent

Having the same value.

The same amount.

Example



A \$2 coin is equivalent to two \$1 coins.

See equivalent fractions

equivalent fractions

Fractions that name the same number or amount.

Examples

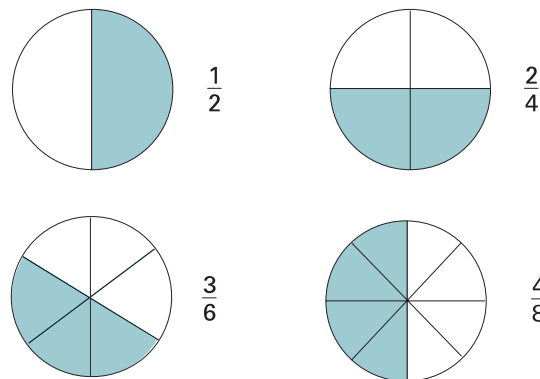

Fractions $\frac{1}{2} = \frac{2}{4} = \frac{3}{6} = \frac{4}{8}$ are equivalent.

See equivalent, fraction

estimate

- (i) A rough or approximate calculation.
- (ii) A number that has not been calculated accurately. Estimated answers are often needed when working with decimals.

Example

In 1.9×3 the estimate will be

$$2 \times 3 = 6$$

$$\therefore 1.9 \times 3 \approx 6$$

- (iii) Trying to judge or guess what a measure or result will be.

Example

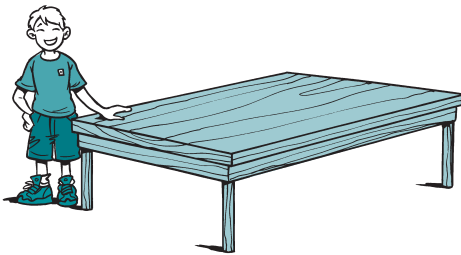

The table is 13 handspans long, that is roughly 2 metres.

See accurate, approximately, calculate, rounding

evaluate

To find the value of.

Examples

- (i) Evaluate 21×3

$$\begin{array}{r} 21 \\ \times 3 \\ \hline 63 \end{array}$$

The value of 21×3 is 63.

- (ii) Evaluate $p + 3q$

Given that $p = 2.5$ and $q = 7$

$$\begin{aligned} p + 3q &= 2.5 + (3 \times 7) \\ &= 2.5 + 21 \\ &= 23.5 \end{aligned}$$

even

Equally balanced, equal in number or amount.

Example

$$\$5 = \$2.50 + \$1 + \$1.50$$

even number

A number that is divisible by two. All even numbers finish with one of the digits: 0, 2, 4, 6 or 8.

See digit, divisible

exact

Precise, accurate, correct in every way, not approximate.

See approximately

exchange

- (i) When we go shopping, we exchange money for goods. Money is the medium of exchange.

Example



\$2.30 is the price of the toy car.

- (ii) Multibase arithmetic blocks (MAB) can be exchanged.

Example

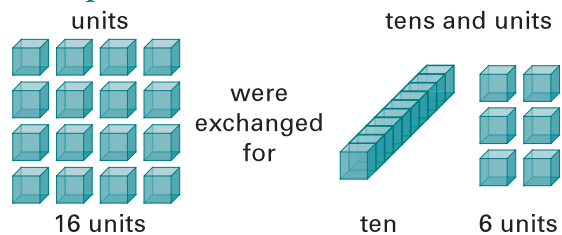

- (iii) Money can also be exchanged for money of equivalent value.

Example



is the same amount as



See equivalent, multibase arithmetic blocks, rate



expand

Write out in full.

Examples

(i) Expand 4

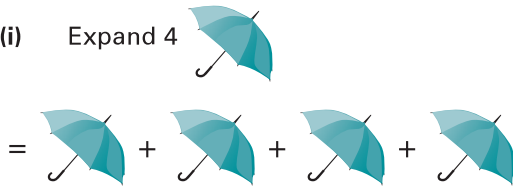

(ii) Expand 537

$$537 = 500 + 30 + 7$$

See expanded notation

expanded notation

A way of writing numerals or algebraic expressions.

Examples

(i) $249 = 200 + 40 + 9$

or $= (2 \times 100) + (4 \times 10) + (9 \times 1)$

or $= 2 \times 10^2 + 4 \times 10^1 + 9 \times 10^0$

(ii) In algebra

$$2(a + 2b) = (2 \times a) + (2 \times 2b)$$

or $= a + a + b + b + b + b$

See index notation, scientific notation

exponent

A symbol indicating how many times the quantity is to be multiplied by itself to produce the power shown. Another word for index.

See base, index, index notation, power of a number

expression

See algebraic expression

exterior

The outside of something.

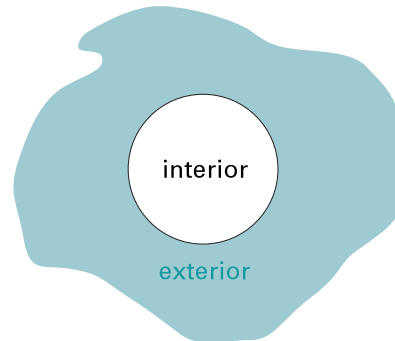

Examples

(i) Exterior angle

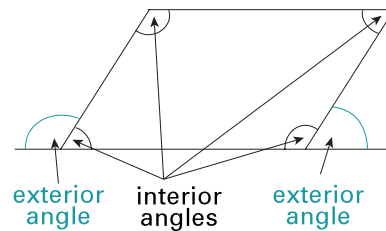

(ii) Exterior angle of a triangle

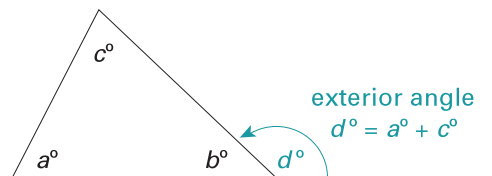

The exterior angle of a triangle is the sum of the two opposite interior angles.

See interior angles

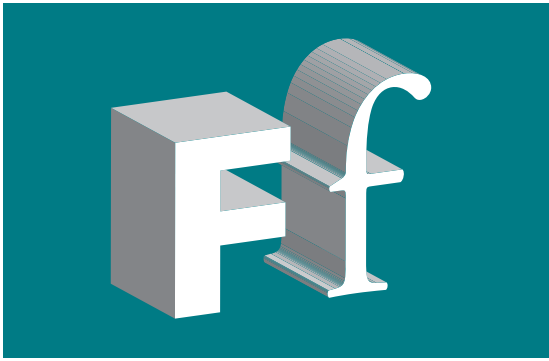

face

In a three-dimensional shape, a face is the flat part of the surface that is bounded by the edges.

Examples

- (i) A cube has six faces.

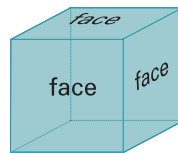

- (ii) A tetrahedron has four faces.

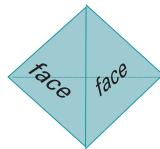

- (iii) A pyramid has five faces.

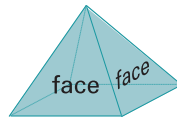

See cube, edge, pyramid, surface, tetrahedron, three-dimensional

factorisation

We can simplify algebraic expressions by extracting a common factor.

Example

Factorise $3a + 6b$

$$\begin{aligned}
 & 3a + 6b \\
 = & \textcircled{3} \times a + 2 \times \textcircled{3} \times b \\
 & \swarrow \quad \searrow \\
 & \text{common factor} \\
 = & 3(a + 2b)
 \end{aligned}$$

See algebraic expression

factors

All the whole numbers that can be divided exactly into another number.

Examples

		factor
(i)	$6 \div 1 = 6$	1
	$6 \div 2 = 3$	2
	$6 \div 3 = 2$	3
	$6 \div 6 = 1$	6

1, 2, 3 and 6 are factors of 6.

(ii) $5 \div 1 = 5$
 $5 \div 5 = 1$

Prime number 5 has only the factors 5 and 1.

See composite number, factor tree, prime number, whole numbers

factor tree

A diagram that shows the prime factors of a given number.

Example

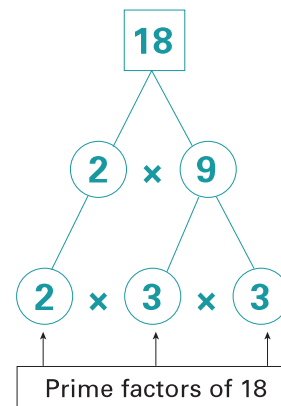

See prime factor of a number



false sentence

A sentence about numbers that is not true.

Examples

$5 < 1$ is a false sentence.

The open sentence $3 + \square = 10$ becomes false if \square is replaced by any other number than 7, e.g. 3, 4, 5 ...

If \square is replaced by 7, it will become a true sentence.

See number sentence, true sentence

Examples

(i) The region inside a square is finite because it is bounded by a perimeter.

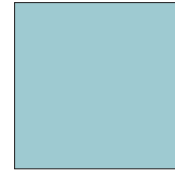

(ii) The set of months in a year is a finite set because the months can be counted.

See infinite, perimeter, region, set

first

The one at the beginning, before any other.

Example

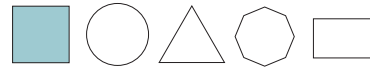

The first shape is a square.

farthest

(furthest)

The longest distance away.

Example

Name	Distance
Kate	3.50 m
Paul	3.89 m
Mike	3.47 m



Paul jumped the farthest.

See distance

flat

(i) Being in one plane only.

Examples

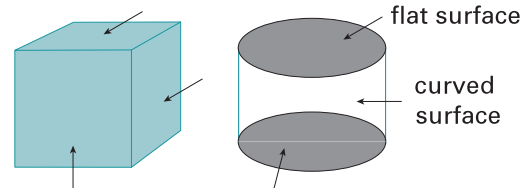

Every face of a cube is flat.

flat surface

(ii) The name used for the multibase arithmetic block representing one hundred.

Example

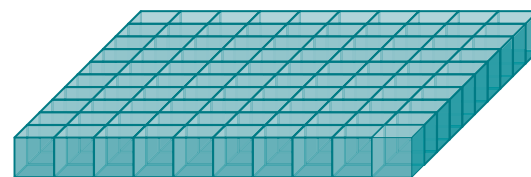

flat

figure

Another name for a numeral, line, shape or a solid.

Examples

(i) Write in figures: thirty-six 36

(ii) Half of this figure has been coloured in.

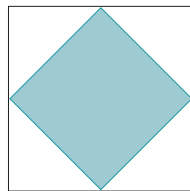

finite

Anything that has boundaries or can be counted.

See cube, face, multibase arithmetic blocks (MAB), plane, surface

flexible

A jointed structure is flexible when its angles can be changed by moving the struts without altering their size or arrangement.

Example



A rectangle forms a flexible structure.

See rigid

flip

To turn over.

Example

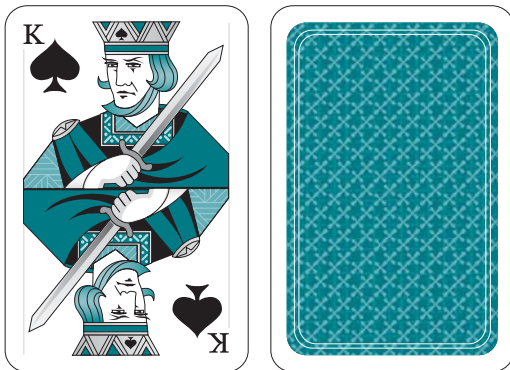

This playing card has been flipped over.

See reflection, slide, turn

foot

(Plural: feet)

(Symbols: ', ft)

A measure of length.

1 foot \approx 30 centimetres

1 foot = 12 inches

The altitude of an aeroplane or the depth of a submarine is measured in feet.

formula

(Plural: formulae, formulas)

An equation that uses symbols to represent a statement.

Example

$$A = lw$$

width
 w

length l

Statement: The area of a rectangle is found when its length is multiplied by its width.

See area, equation, symbol

fortnight

Fourteen days or two weeks.

fraction

A part of a whole quantity or number.

Examples

- (i) The fraction $\frac{3}{4}$ means 3 parts out of a total of 4 equal parts.

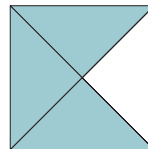

3 parts out of 4 parts are coloured.

- (ii) 7 parts out of 100 parts are coloured in.

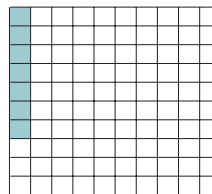

The fraction is $\frac{7}{100}$

- (iii) Show $\frac{3}{4}$ of 8.

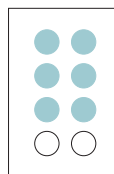

$$\frac{6}{8} = \frac{3}{4}$$

See cancelling, common denominator, decimal fraction, equivalent fractions, improper fraction, mixed number, proper fraction, simple fraction

frequency

The frequency of any item in a collection of data is the number of times that item occurs in the collection.

Example

We tossed a die 50 times and recorded the number for each throw. We kept a tally of the 50 scores.



Number	Tally	Frequency
1	HHH	7
2	HHH HHH	12
3	HHH	9
4	HHH	8
5	HHH	6
6	HHH	8

Number 2 had the highest frequency. Number 5 had the lowest frequency.

See data, frequency distribution, tally

frequency distribution

A graph or table showing how often an event or quantity occurs.

Example

A frequency distribution table of marks:

Mark	Tally	Frequency
20–29		1
30–39	HHH	5
40–49	HHH	9
50–59	HHH	8
60–69	HHH	5
70–79		3
80–89		1
	Total	32

frequency table

See frequency distribution

front view

A diagram of an object, as seen from directly in front of it.

Example

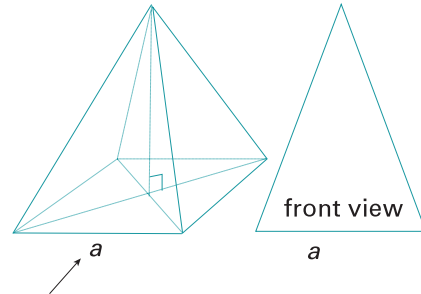

See plan, side view

frustum

A pyramid cut by a plane parallel to the pyramid's base.

Example

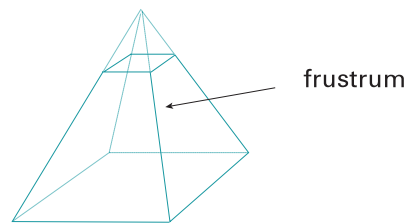

See decahedron, pyramid, section



g

- (i) g is the symbol for the unit gram.
- (ii) It is also a symbol for gravity. The force of gravity on the Earth's surface is 1 g.

See mass, weight

gallon

Measure of volume.

1 imperial gallon \approx 4.5 litres

geo-board

A board studded with nails forming a pattern or grid, usually of squares or equilateral triangles.

Geo-boards are used for shape and number activities in which elastic bands are arranged around sets of nails.

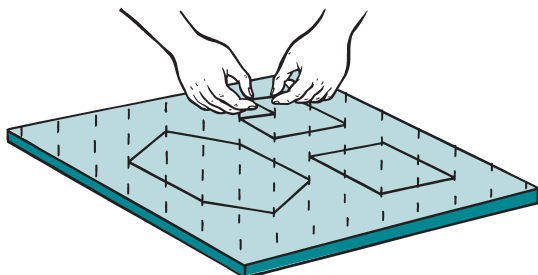

See equilateral triangle, grid, pattern

geometric progression

See progression

geometry

The part of mathematics that deals with the relationships, properties and measurements of solids, surfaces, lines, angles and space.

See measure, property, solid, space, surface

geo-strips

Strips of plastic, metal or cardboard with holes equally spaced down the centre of the strips. They are used for making shapes.

Examples

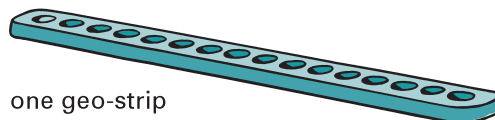

one geo-strip

Shapes made using geo-strips

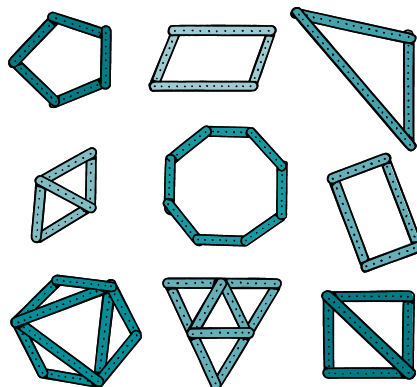

See flexible, rigid

Goldbach's conjecture

Every even, natural number is equal to the sum of two prime numbers.

$$2 = 1 + 1 \quad 10 = 3 + 7$$

$$4 = 2 + 2 \quad 12 = 5 + 7 \text{ or } 1 + 11$$

$$6 = 3 + 3 \quad 24 = 11 + 13$$

$$8 = 1 + 7 \quad 42 = 19 + 23$$

See natural number, prime number



googol

A very large number. It has the numeral 1 with one hundred zeros after it.

1 000 000 000 000 000 000 000 000 000
000 000 000 000 000 000 000 000 000 0...

gradient

Measurement of slope, inclination to horizontal base, or pitch. It can be measured and expressed as a ratio.

Examples

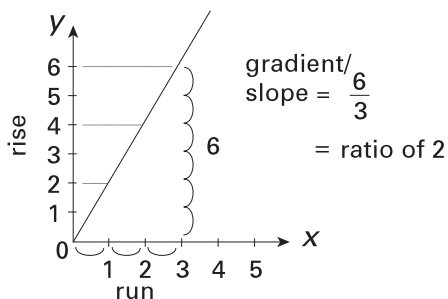
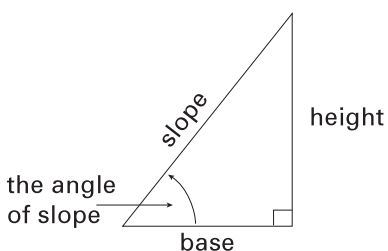

The ratio $\frac{\text{height}}{\text{base}}$ or $\frac{\text{rise}}{\text{run}}$ is called the slope, the gradient or the pitch.

See Pythagorus' theorem, tangent ratio

graduated

Marked off with measurements.

Examples

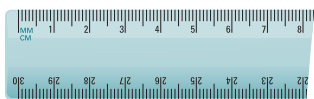

ruler

A ruler is graduated in centimetres.



thermometer

A thermometer is graduated in degrees.

gram

(Symbol: g)

A unit of mass.

$$1000 \text{ g} = 1 \text{ kg}$$

Examples



The mass of this box of chocolates is 250 grams.

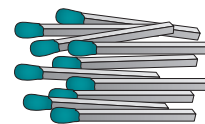

The mass of ten matches is approximately 1 gram.

See mass, unit of measurement

graph

Drawings or diagrams which show information, usually about how many things.

There are different kinds of graphs.

Examples

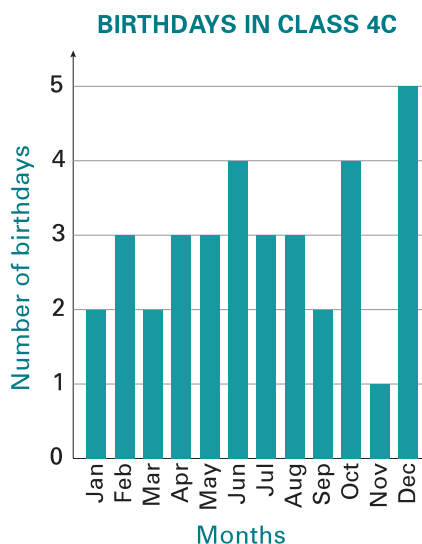

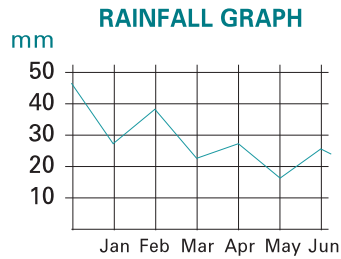

This is a line graph.

See axis, bar graph, column graph, line graph, pictograph, pie graph

greater than

(Symbol: >)

A relation between a pair of numbers showing which is greater. More than. Bigger than.

Example

$$7 > 6$$

↑
greater than

See less than

grid

Regular lines that go across, up and down. Often found on maps and graphs.

Examples

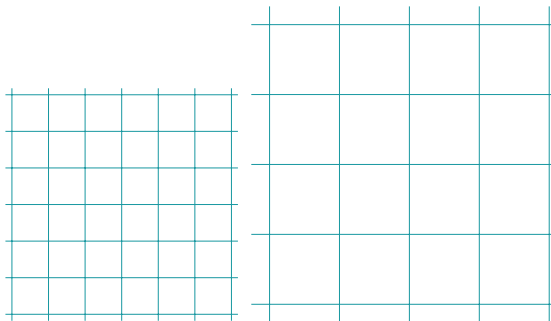

See isometric paper, square paper

gross

Twelve dozen, 144.

gross mass

The mass of an object together with its container.

Example

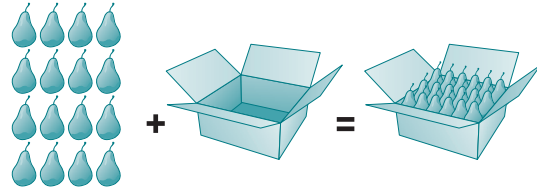

net mass + tare = gross mass

The actual mass of the object is called net mass. The mass of the packaging is called tare.

See mass

group

- (i) Putting things together in a set or group. In the decimal system things are grouped into tens.

Example

Hundreds	Tens	Units
2	4	3

243 = 2 groups of 100
4 groups of 10
3 groups of 1

- (ii) Two or more things.

Example

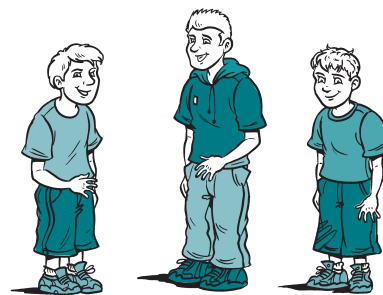

a group of boys

See grouping



grouping

Putting things together into sets with the same number in each set.

Example

How many groups of four can be made with twenty balls?

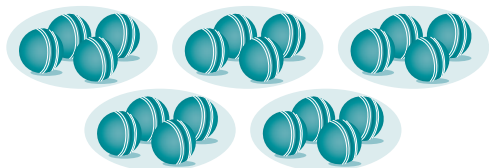

Answer: Twenty balls are put into five groups of four.

See division, set

grouping symbols

See braces, brackets, order of operations, parentheses



h

Symbol for height, hour, prefix hecto-.

ha

A symbol for hectare.

half

(Plural: halves)

One part of two equal parts.

Examples

(i)

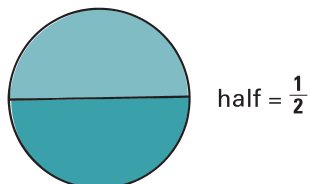

(ii) Half of twenty-four is twelve.

$$\frac{1}{2} \times 24 = 12$$

(iii) An orange has been cut into two halves.



handspan

The distance from the top of the thumb to the top of the smallest finger when the hand is fully stretched.

Example

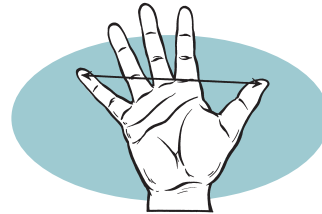

This is a handspan

A handspan is used as an arbitrary measure for estimating the lengths, heights or widths of objects.

See arbitrary unit, estimate



hecta, hecto

Prefix that means 100.

See hectare

hectare

(Symbol: ha)

A unit of area.

One hectare is the area of a square with sides measuring 100 metres.

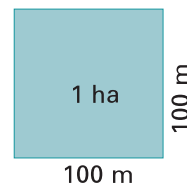

The area of a soccer field is approximately half a hectare.

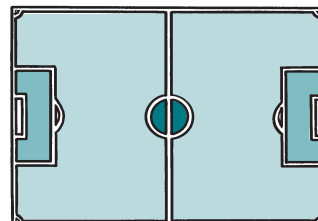

See area, unit of measurement

heft

To judge the weight of objects by lifting them in the hands.

Examples

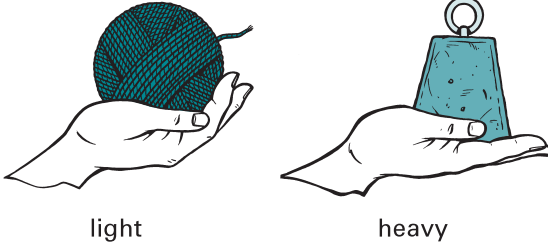

See weight

height

Measurement from top to bottom, the vertical distance.

Examples

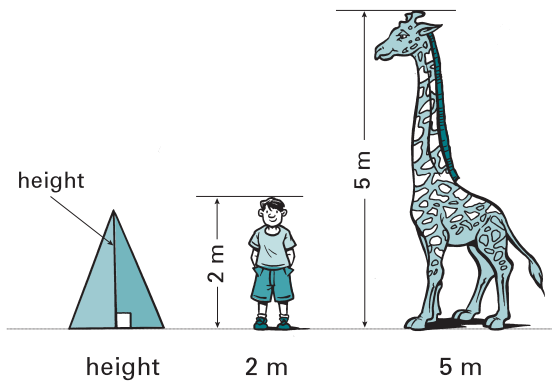

See altitude, vertical

hemisphere

Half of a sphere.

Example

Australia lies in the southern hemisphere.

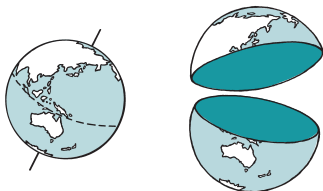

Each part is $\frac{1}{2}$ of a sphere.

See sphere

heptagon

A polygon with seven sides and seven angles. Regular heptagons have all sides congruent and all angles the same.

Examples

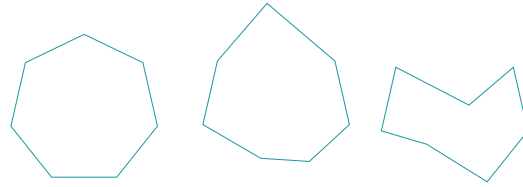

regular heptagon irregular heptagons

See polygon

hexagon

A shape (polygon) which has six sides and six angles.

Examples

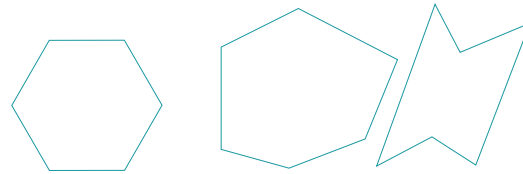

regular hexagon irregular hexagons

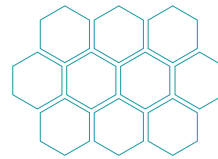

Honeycomb is made up of regular hexagons.

See polygon

hexagram

A shape formed by two intersecting equilateral triangles.

Example

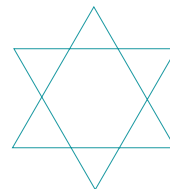

hexahedron

A solid (polyhedron) with six faces. All cuboids are hexahedrons.

A cube is a regular hexahedron; all six faces are congruent squares, all internal angles are equal.

Examples

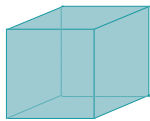

regular hexahedron

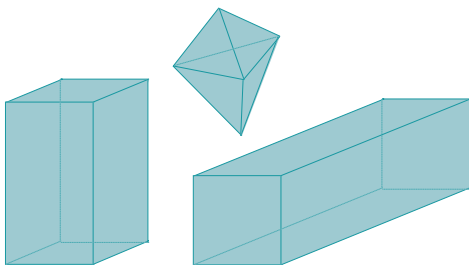

irregular hexahedron

See cube, cuboid, polyhedron, prism, regular polyhedron

highest common factor

(HCF)

The largest number that divides into all given numbers.

Example

For given numbers 8, 12, 16 and 20 the highest common factor (HCF) is 4.

See factors, factor tree

Hindu–Arabic

Our modern system of numbers is the result of centuries of development.

The symbols for all the digits, except zero, probably originated with the Hindus in India, as early as 200 BC.

Hindu numerals



The Arabs adopted the system.

Arabic numerals (13th-century AD)



The numerals, including zero, were standardised after the invention of the printing press in the 15th century.

0 1 2 3 4 5 6 7 8 9

The modern system has very useful characteristics:

- (i) it has only ten digits: 0, 1, 2, 3, 4, 5, 6, 7, 8, 9
- (ii) it uses zero as a place holder
- (iii) it uses place value system: the value of the digit depends on its placement in the numeral:

37 307 13700

See numeral, place holder, place value

histogram

A column graph with no spaces between columns.

Example

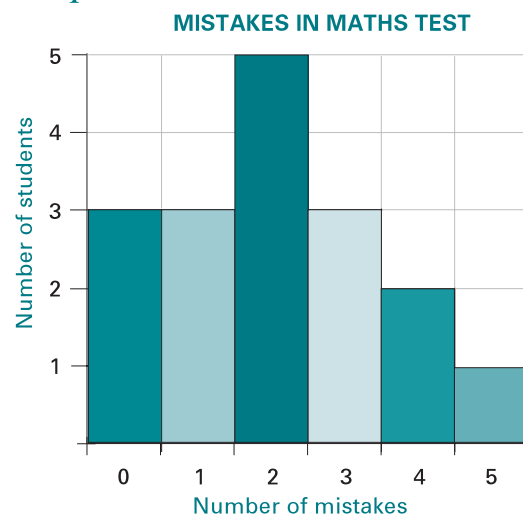

See column, column graph

horizon

Line at which land and sky appear to meet.

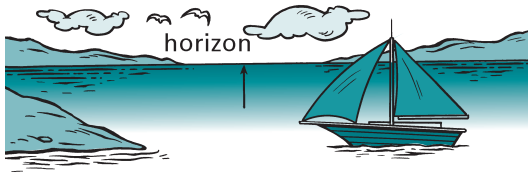

See horizontal line

hour

(Symbol: h)

A unit of time.

$$1 \text{ hour} = 60 \text{ minutes}$$

$$1 \text{ hour} = 3600 \text{ seconds}$$

$$24 \text{ hours} = 1 \text{ day}$$

See unit of measurement

hundred

$$100 = 10 \times 10 \text{ or } 10^2$$

See decimal place-value system

hypotenuse

The longest side of a right-angled triangle, which is the side opposite the right angle.

Example

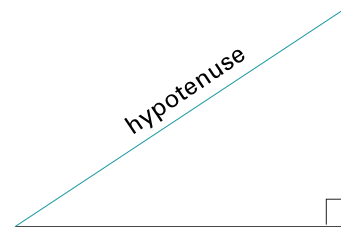

See Pythagoras' theorem, right-angled triangle

horizontal line

Line parallel to, or on a level with, the horizon.

A vertical line is at right angles to the horizon.

Example

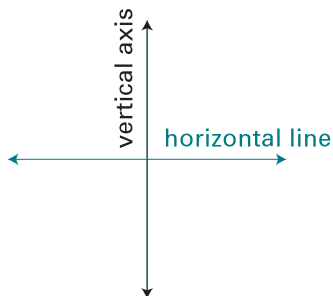

See axis, bar graph, base line, parallel lines, right angle, vertical

horizontal surface

Any surface which is parallel to, or on a level with, the horizon.

Example

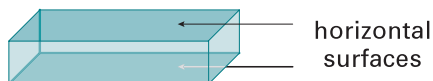

See horizon, parallel lines, surface



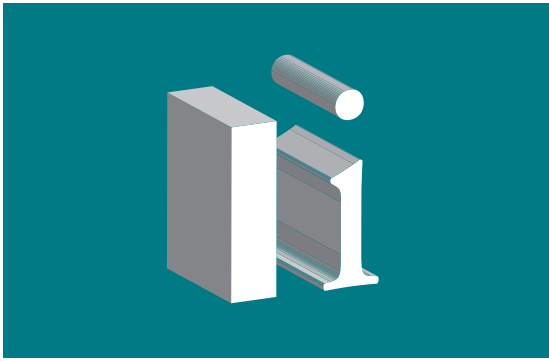

icosahedron

A solid (polyhedron) with twenty faces.

A regular icosahedron is formed by joining together twenty congruent equilateral triangles.

Example

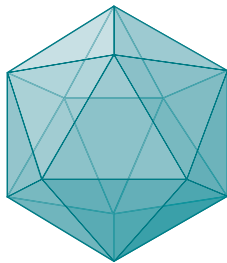

regular icosahedron

See polyhedron, regular polyhedron

identical

Exactly alike.

Examples



5 5

image

An exact copy of an object.

Example

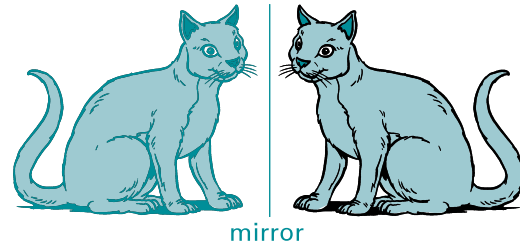

mirror

The image in a mirror

See mapping, mirror image, reflection

improper fraction

A fraction whose numerator is greater than its denominator.

Example

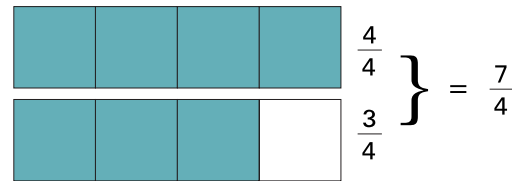

See denominator, fraction, mixed number, numerator, proper fraction

inch

(Symbol: ", in)

A measure of length.

$$1 \text{ inch} = 2.54 \text{ cm}$$

$$12 \text{ inches} = 1 \text{ foot}$$

increase

Make larger by adding a certain amount, or multiplying by a number.

Examples

- (i) The price of a three-dollar bus ticket has been increased by fifty cents.

$$\$3 + 50c = \$3.50$$

▣ **increase** *continued...*



- (ii) My family of 2 cats has increased 3 times. How many kittens do I have now?

$$2 \times 3 = 6$$

$$6 - 2 = 4$$

I have 4 kittens.

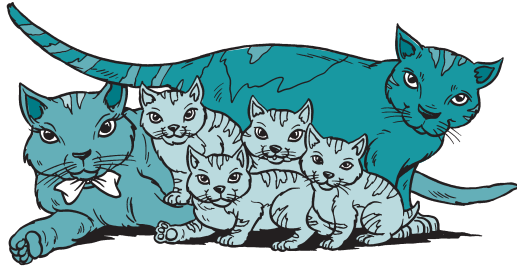

See decrease, progression

index

(Plural: indices)

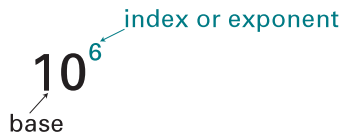

Index is also called exponent.

In ${}^3\sqrt{5}$ the index is 3. Where no index is written, as in $\sqrt{5}$, the index is 2.

See base, exponent, index notation, square root

index laws

In algebra, when working with indices or algebraic expressions, these laws must be remembered:

Law

$$x^a \times x^b = x^{a+b}$$

$$\frac{x^a}{x^b} = x^{a-b}$$

$$x^0 = 1$$

$$(x^a)^b = x^{a \times b} = x^{ab}$$

$$(x \times y)^a = x^a y^a$$

$$\left(\frac{x}{y}\right)^a = \frac{x^a}{y^a}$$

$$x^{-a} = \frac{1}{x^a}$$

$${}^n\sqrt{a} = a^{\frac{1}{n}}$$

Example

$$5^3 \times 5^2 = 5^{3+2} = 5^5$$

$$\frac{5^3}{5^2} = 5^{3-2} = 5^1 = 5$$

$$5^0 = 1$$

$$(5^3)^2 = 5^{3 \times 2} = 5^6$$

$$(5 \times 4)^3 = 5^3 \times 4^3$$

$$\left(\frac{5}{4}\right)^3 = \frac{5^3}{4^3}$$

$$5^{-3} = \frac{1}{5^3}$$

$${}^3\sqrt{5} = 5^{\frac{1}{3}}$$

index notation

A shorthand way of writing large numbers such as 1 000 000. Also called scientific notation.

Example

Using index notation:

$$1\,000\,000 = 10 \times 10 \times 10 \times 10 \times 10 \times 10 \times 10 = 10^6$$

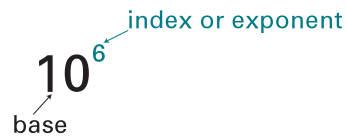

is read as:

'ten to the power of six' or

'ten to the sixth power'.

See base, cubed number, power of a number, scientific notation, square number

inequality

A statement that one quantity is less than or greater than another.

The symbols $<$, $>$ and \neq are used to express inequalities.

Examples

$5 \neq 6$ Five is not equal to 6.

$5 < 6$ Five is less than 6.

$6 > 4$ Six is greater than 4.

See equality, greater than, less than, not equal

inequality signs

SIGN MEANING

$<$	less than
\leq	less than or equal to
\neq	not equal to
$>$	greater than
\geq	greater than or equal to

inequation

A statement that two quantities are not equal.

Example

$$x + \underset{-5}{5} > \underset{-5}{7}$$

$$x > 2$$

This inequation is true for any number greater than 2, for example 3, because $3 + 5 = 8$, which is greater than 7.

See equality, equation, inequality

infer

Make a predictive statement or conclusion, based on observation or reasoning.

See prediction

infinite

Without bounds of size or number, unlimited, not finite, endless.

Example

{Whole numbers} is an infinite set.

See finite, set, whole numbers

infinite decimal

(not terminating)

Decimals which go on without end.

Example

$$\pi = 3.1415927\dots$$

See recurring decimal, terminating decimal



infinity

(Symbol: ∞)

Expressing quantity without bounds.

See infinite

input

See number machine

insignificant zeros

Unnecessary zeros in decimal numbers.

Examples

wrong	correct
05.2	5.2
9.980	9.98
.25	0.25

integers

Positive or negative whole numbers including zero.

Examples

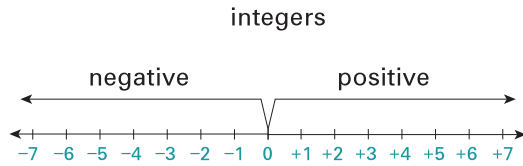

The set of integers:

$\{-6, -5, -4, -3, -2, -1, 0, 1, 2, 3, 4, 5, \dots\}$

See directed numbers, negative numbers, positive numbers, set, whole number

interest

Price that is charged or paid for the use of money.

Examples

- (i) The bank pays interest to a person who puts money into a savings account, as the bank can use that money to lend it to someone else.
- (ii) People who borrow money from a bank have to pay the bank interest on the amount borrowed, in return for using the bank's money.

See interest rate, principal

interest rate

The interest rate is a rate that is charged or paid for the use of money. It is often expressed as an annual percentage of the principal.

Examples

- (i) Joshua borrows \$100 from a bank at a rate of interest of 10 per cent per annum.
The interest Joshua has to pay after a year is 10% of \$100, which is $\frac{10}{100} \times \$100 = \10
- (ii) Oliver puts \$100 into his savings account. The interest rate the bank pays on savings accounts is 6% annually.
Oliver receives 6% of \$100, which is $\frac{6}{100} \times \$100 = \6

See annual, interest, principal

intercept

When drawing graphs of equations, an intercept is the point where the equation line crosses an axis.

Example

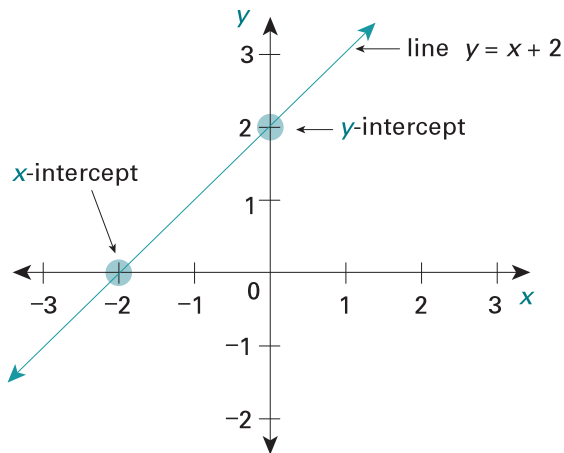

The line $y = x + 2$ crosses the y -axis at point $(0, 2)$. The point $(0, 2)$ is called the y -intercept.

The line also crosses the x -axis at point $(-2, 0)$, which is called the x -intercept.

See coordinates, gradient

interior

The inside of something.

See exterior

interior angles

Angles inside a shape.

Example

The sum of interior angles inside any triangle is 180° .

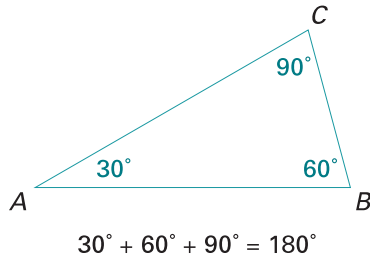

See exterior

intersect

To cut across. To cross each other.

Example

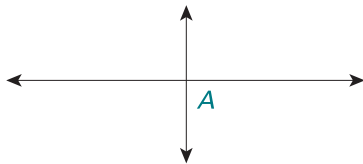

The two lines intersect at point A.

intersection

- (i) The place where two or more lines meet, like an intersection of two streets.

Example

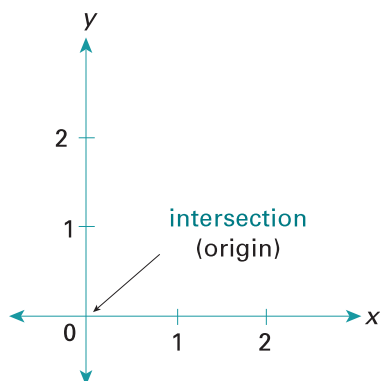

- (ii) The region where shapes overlap.

Example

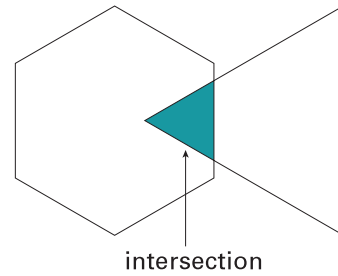

- (iii) (Of sets) The set of elements that are common to both sets.

Example

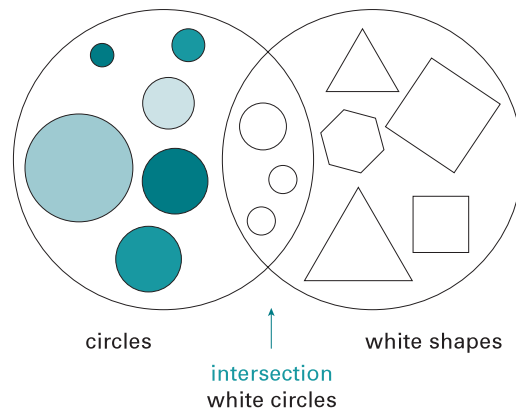

See coordinates, origin, region, set, shape

interval

The amount of time, or distance, between two events or places.

Examples

- (i) There is a twenty-minute interval between the two films.
 (ii) Line segment



See line

inverse

Inverted in position, order or relation. When one quantity increases, the other decreases at the same rate.

See additive inverse, invert, proportion, ratio

inverse factor tree

A diagram that shows prime numbers and the number they belong to.

Example

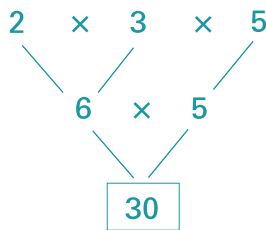

Prime numbers: 2, 3 and 5 have a product of 30.

See factor tree, prime factor of a number

inverse operations

The operation which reverses the action of the original operation.

Examples

The operations

$$4 + 3 = 7 \text{ and}$$

$$7 - 3 = 4$$

are the inverse of one another.

The operations

$$6 \times 3 = 18 \text{ and}$$

$$18 \div 3 = 6$$

are the inverse of one another.

See operation, reciprocal

invert

Turn upside down, reverse position.

Examples

$$\frac{1}{2} \text{ inverts to } \frac{2}{1} \text{ or } 2$$

$$\frac{3}{4} \text{ inverts to } \frac{4}{3} \text{ or } 1\frac{1}{3}$$

irrational number

Number that cannot be written as an integer or ratio.

Examples

$$\pi \quad \sqrt{2} \quad \sqrt{3} \quad \sqrt[3]{2}$$

See rational number, real number

irregular polygon

A shape in which not all sides are equal in length, and/or at least one angle is different in size from the other angles.

Examples

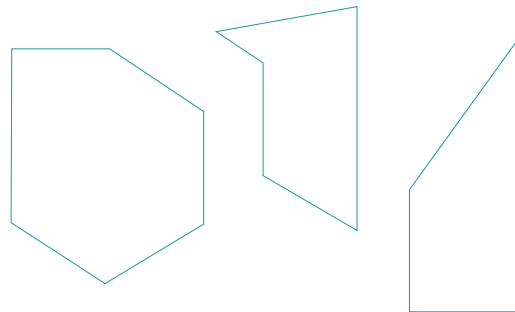

See polygon, regular polygon

isometric drawing

A drawing where the three dimensions are represented by three sets of lines 120° apart, and all measurements are in the same scale (not in perspective).

Example

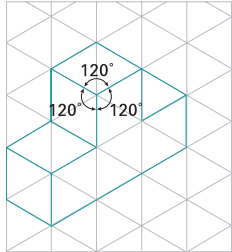

See perspective

isometric paper

Paper with dots or lines that make equilateral triangles. Used for isometric drawings.

Example

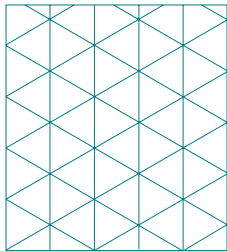

See dot paper, equilateral triangle, square paper

isosceles triangle

A triangle in which two sides have the same length and two angles have the same size.

Examples

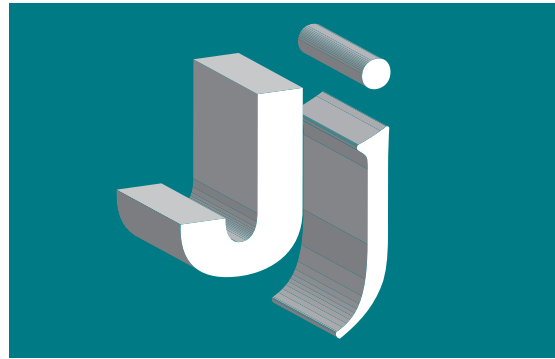
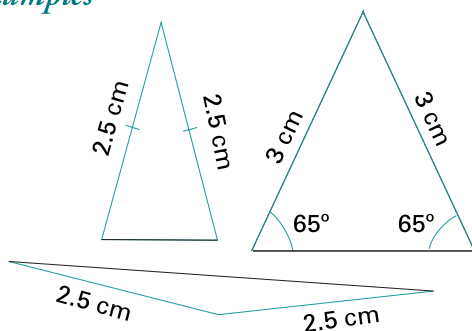

jigsaw

A puzzle in which pieces fit together to form a picture.

Example

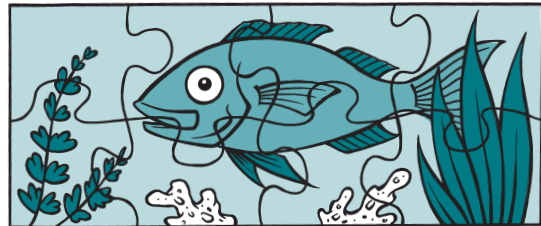

joule

Unit of energy or work. It replaces the old unit, calorie.

See kilojoule



kilogram

(Symbol: kg)

The base unit of mass.

$$1 \text{ kg} = 1000 \text{ g}$$

Examples

The mass of this packet of sugar is 1 kilogram.



The mass of this girl is 27 kilograms.



See gram, mass, unit of measurement

kilojoule

(Symbol: kJ)

Used for measuring energy or work.

$$1 \text{ kilojoule} = 1000 \text{ joules}$$

Example

A piece of chocolate cake has 2000 kilojoules.

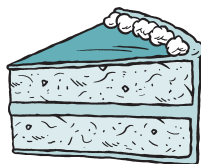

kilolitre

(Symbol: kL)

A unit of volume (capacity) for measuring liquids.

$$1 \text{ kL} = 1000 \text{ L}$$

Example

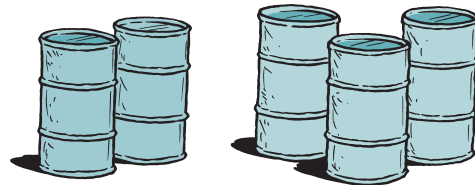

Five 200-litre oil drums hold one kilolitre.

See capacity, unit of measurement, volume

kilometre

(Symbol: km)

A unit of distance. Distances between towns are measured in kilometres.

$$1 \text{ km} = 1000 \text{ m}$$

Example

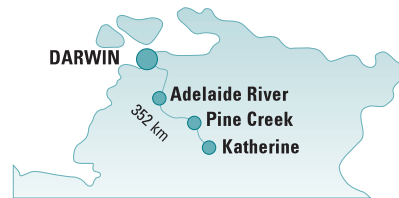

The road distance from Darwin to Katherine is 352 kilometres.

See distance, unit of measurement

kite

A quadrilateral that is shaped like this.

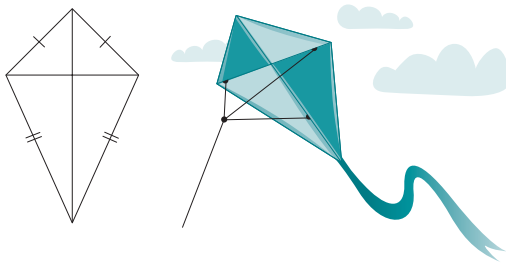

The two short sides are equal in length.

The two long sides are equal in length.

The diagonals are perpendicular to each other.

See quadrilateral

knot

(Symbol: kn)

Measure of speed at sea and in aviation, equal to travelling one nautical mile per hour.

1 nautical mile = 1.852 kilometres

Example

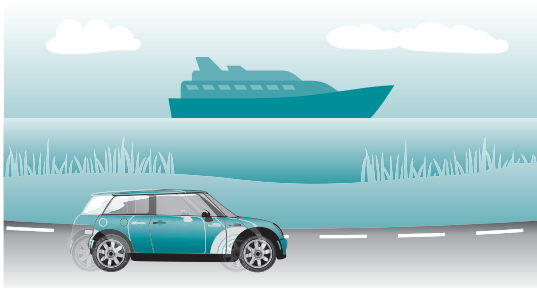

A ship moving at 20 knots is travelling as fast as a vehicle on land travelling about 37 kilometres per hour.

See speed



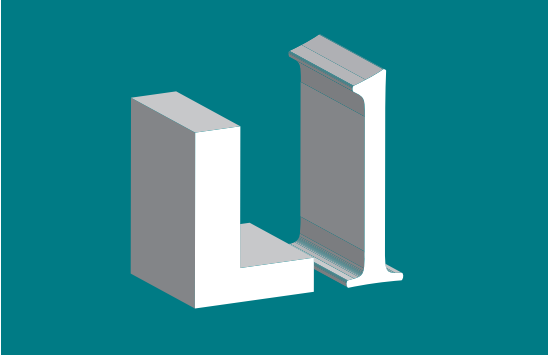

L

- (i) L is the symbol for litre.
- (ii) In Roman numerals L stands for fifty.

See capacity, litre

lateral

See equilateral

LCD

See lowest common denominator

LCM

See lowest common multiple

leap year

A year which has 366 days instead of 365 days. It occurs every four years.

In a leap year February has twenty-nine days instead of twenty-eight days.

When the year number can be divided by 4 leaving no remainder, then it is a leap year.

Example

$$1979 \div 4 = 494 \text{ (r3)}$$

This is not a leap year.

$$2012 \div 4 = 503$$

This is a leap year.

Century years are not leap years unless they are divisible by 400.

Example

1600, 2000, 2400 are leap years.

1500, 1700, 1800 are not leap years.

least

The smallest thing or amount in a group.

Example

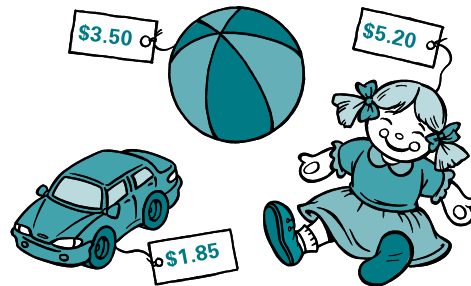

The toy car costs the least amount.

length

How long something is from end to end.

- (i) The measure of distance.

Examples

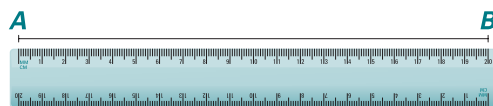

This ruler is 20 centimetres long.

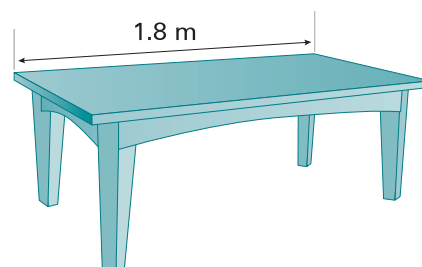

The length of this table is 1.8 metres.

Units of length are:

millimetre	mm
centimetre	cm
metre	m
kilometre	km

(ii) An interval of time.

Example

How long is the lunchtime break?

See centimetre, distance, interval, kilometre, metre, millimetre

less than

(Symbol: <)

A relation between pairs of numbers showing which is smaller.

Example

$$5 < 7$$

↑
less than

See greater than, inequality signs

like terms

Similar, resembling each other.

In algebra, expressions are called like terms if they have the same variable and power. Like terms can be added and subtracted; terms that are not like cannot.

Examples

Like terms

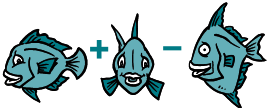
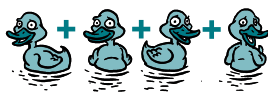

$$4x - 3x$$

$$5x^2y + x^2y$$

Unlike terms

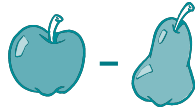

$$a - b$$

$$3x^2 + 3$$

See power of a number, unlike terms, variable

line

A long thin mark drawn on a surface. It can be straight or curved. It has no thickness and has only one dimension. A straight line extends without end in both directions.



A straight line is the shortest possible distance between two points.

Example



The line between A and B is the shortest distance between A and B . The arrowheads indicate that the line does not end where we stop drawing it. The interval AB has a finite length.

See curve, horizontal line, infinite, interval, line segment, vertical

linear

Involving measurement in one dimension only.

See line



linear equation

An equation that can be presented as a straight line.

Examples

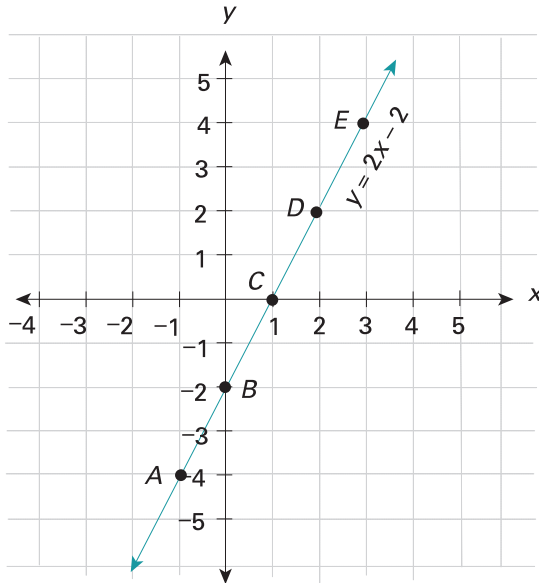

	A	B	C	D	E
x	-1	0	1	2	3
y	-4	-2	0	2	4

$$y = 2x - 2$$

See equation

line graph

A graph formed by segments of straight lines that join the points representing certain data.

Example

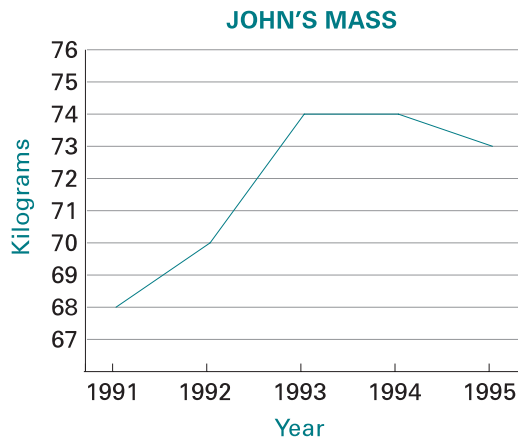

See graph, line, line segment

line of symmetry

The line which divides something in half so that one half is the mirror image of the other half. This line is sometimes called an axis of symmetry.

A shape may have more than one line of symmetry.

Examples

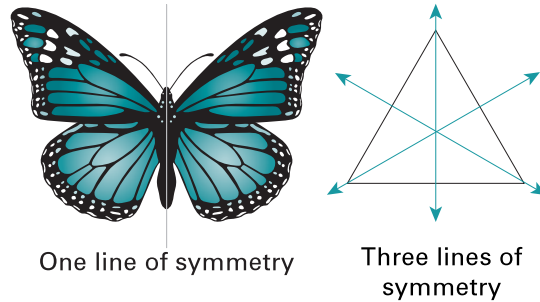

One line of symmetry

Three lines of symmetry

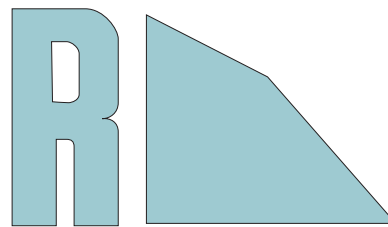

Some shapes have no line of symmetry.

See asymmetry, axis, symmetry

line segment

Part of a straight line.

Example

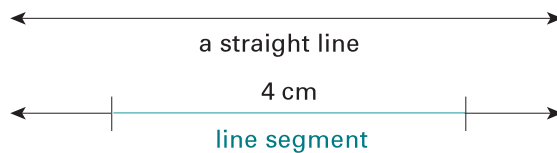

See diameter, line

litre

(Symbol: L)

A unit of capacity used to measure the volume of liquids or the capacity of containers.

$$1 \text{ L} = 1000 \text{ cm}^3 = 1000 \text{ mL}$$

$$1000 \text{ L} = 1 \text{ kL}$$

Example



A carton of milk holds one litre.

See capacity, unit of measurement, volume

loss

If the selling price is lower than the cost price, the seller makes a loss.

Example

A car dealer buys a car for \$10 000 and sells the same car for \$9000. As the selling price of the car is less than the buying price, the dealer suffers a loss of \$1000.

See cost price, profit, selling price

lowest common denominator

(LCD)

The lowest counting number that is divisible by the denominators of given fractions.

The lowest multiple of two or more denominators.

Example

What is the LCD of fractions $\frac{1}{4}$ and $\frac{1}{10}$?

4 divides exactly into } 4, 8, 12, 16, **20**, 24,
(Multiples of 4 are) } 28, 32, 36, **40**, 44 ...

10 divides exactly into } 10, **20**, 30, **40**, 50,
(Multiples of 10 are) } 60, 70 ...

The lowest number into which 4 and 10 divide exactly is 20.

Therefore 20 is the LCD.

Lowest common denominators are used in addition and subtraction of fractions.

Example

$$\frac{1}{4} + \frac{1}{10} = \frac{5+2}{20} = \frac{7}{20}$$

See common denominator, counting number, denominator, fraction, lowest common multiple

lowest common multiple

(LCM)

The lowest counting number that is a multiple of given numbers.

Example

What is the LCM of 2 and 3?

The multiples of 2 are:

2, 4, **6**, 8, 10, **12**, 14, 16, **18** ...

The multiples of 3 are:

3, **6**, 9, **12**, 15, **18**, 21, ...

Common multiples are: 6, 12, 18...

The lowest common multiple of 2 and 3 is 6.

See counting number, multiple





m

- (i) m is the symbol for metre.
- (ii) m is also the symbol for prefix milli-.

M

- (i) M is the symbol for prefix mega-.
- (ii) In Roman numerals M means 1000.

M

MAB

See multibase arithmetic blocks

magic square

A puzzle where the numbers are arranged in a square so that each row, column and diagonal add up to the same total.

Example

9	2	7	18
4	6	8	18
5	10	3	18
18	18	18	18

magnitude

The size, or how big something is.

Example

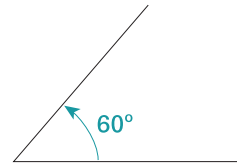

The magnitude of this angle is 60° .

See directed numbers

many-to-one correspondence

A match between members of two sets in which more than one element of the first set is associated with one element of the second. Arrows are used to show the relationship.

Example

Children and their favourite drinks

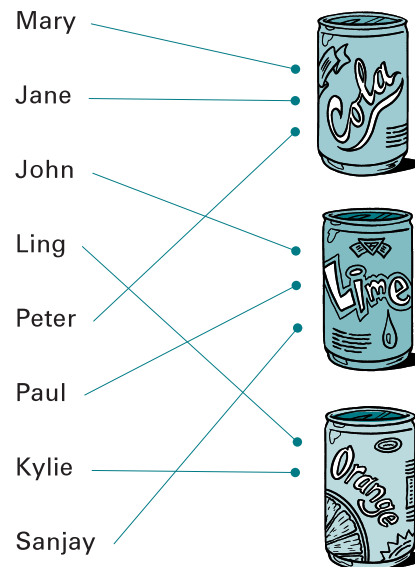

Three elements (Mary, Jane and Peter) of the first set are associated with one element (Cola) of the second set.

See arrow diagram, one-to-one correspondence

mapping

A matching operation between two sets in which each member of the first set is assigned only one member of the second set as a partner or image.

Example

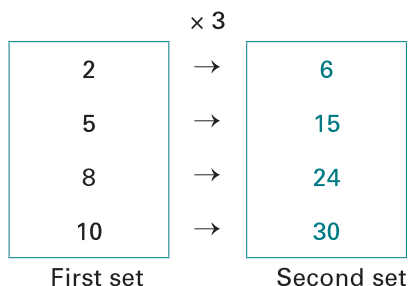

In the above example, 2 maps onto 6, so 6 is the image of 2.

See image, many-to-one correspondence, one-to-one correspondence, set

mass

The amount of matter contained in an object.

Units of mass:

gram	g
kilogram	kg
tonne	t
1000 g	= 1 kg
1000 kg	= 1 t

Example

This boy has a mass of 28 kilograms.



The word 'weight' is commonly but incorrectly used instead of mass.

See beam balance, unit of measurement, weight

matching

See many-to-one correspondence, one-to-one correspondence

mathematical shorthand

Instead of long sentences, mathematics uses numbers, symbols, formulas and diagrams.

Example

The sentence, 'The area of a triangle is found when its base is multiplied by its perpendicular height and then divided by two,' is written in mathematical shorthand as:

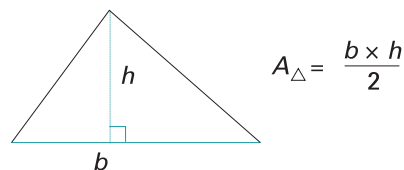

See formula

maximum

The greatest or biggest value.

Examples

- (i) The maximum temperature this month was 39° C.

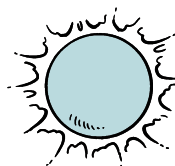

- (ii) The maximum speed is 110 kilometres per hour.



See minimum

maze

A kind of puzzle in which a person has to find a way through a network of lines, paths, etc.

Example

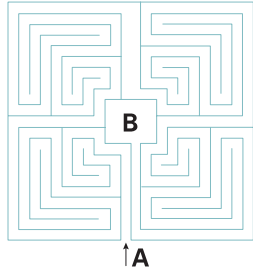

Follow the path from A to B without crossing any lines.

mean

The mean is the average of a set of scores. It is found by adding up all scores and dividing the sum by the number of scores.

$$\text{Mean} = \frac{\text{sum of scores}}{\text{number of scores}}$$

See average, measures of central tendency

measure

- (i) Find out the size of something.

Examples

How long? How tall? How heavy? How hot?

- (ii) Compare quantities. A number assigned to a quantity which indicates its size compared to a chosen unit.

Example

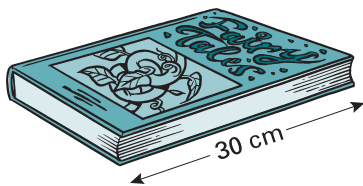

The length of the book is thirty centimetres.

See unit of measurement

measures of central tendency

The three measures of central tendency are: mode, median and mean. They usually lie about the middle of the distribution and tell us certain facts about it.

See mean, median, mode

median

In statistics, median is the middle measurement or score, when items are arranged in order of size.

Example

Scores: 2, 2, 4, 5, 6, 8, 10

↑
median = 5

Where there is no middle score, an average of the two central scores is taken.

Example

Scores: 2, 3, 4, 8, 9, 10

↑ ↑
median = $\frac{4+8}{2} = 6$

See average, mean, measurements of central tendency, mode, score

mega

(Symbol: M)

Prefix meaning one million times.

See megalitre



megalitre

(Symbol: ML)

A unit of capacity.

$$1 \text{ megalitre} = 1\,000\,000 \text{ litres}$$

$$1 \text{ ML} = 1\,000\,000 \text{ L}$$

Example

Volume (capacity) of this swimming pool is:

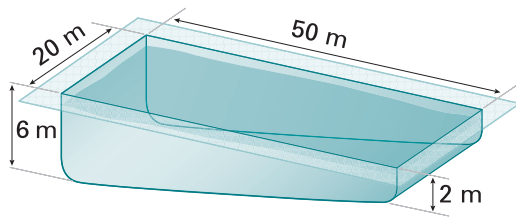

$$\text{Volume} = [50 \times 20 \times (6-2)] \text{ m}^3$$

$$= 4000 \text{ m}^3$$

$$= 4\,000\,000 \text{ L}$$

$$= 4 \text{ ML}$$

This swimming pool contains four megalitres (4 ML) of water.

See Decimal system prefixes on page 153

mensuration

The branch of mathematics concerned with the measurement of lengths, areas and volumes.

metre

(Symbol: m)

The base unit of length (distance).

$$1 \text{ m} = 100 \text{ cm}$$

$$1 \text{ m} = 1000 \text{ mm}$$

Example

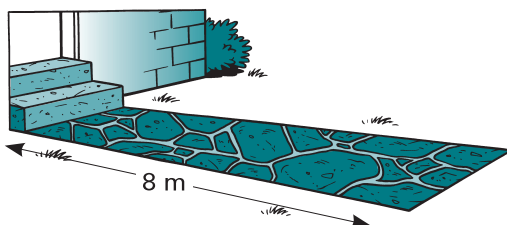

The path is eight metres long.

See distance, unit

metric system

A decimal system of weights and measures.

The base unit for length is metre, for mass is kilogram, and for time is second.

See decimal system, SI, unit of measurement

midpoint

A point in the middle of an interval.

Example

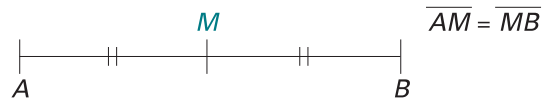

The point M is the midpoint of the interval AB .

See bisect, bisector

mile

An imperial measure of length.

$$1 \text{ mile} \approx 1.6 \text{ km}$$

mileage

The distance travelled during which the car uses a certain amount of petrol. It used to mean miles per gallon of petrol. It now means the number of kilometres per litre of petrol, or consumption of petrol per 100 kilometres.

See gallon, mile

milli

(Symbol: m)

Prefix meaning one-thousandth.

See milligram, millilitre



milligram

(Symbol: mg)

A very small unit of mass, used when working with medicines and chemicals. It is one-thousandth of a gram.

$$1 \text{ mg} = \frac{1}{1000} \text{ g}$$

$$1 \text{ mg} = 0.001 \text{ g}$$

See gram

millilitre

(Symbol: mL)

A unit of capacity.

$$1000 \text{ mL} = 1 \text{ L}$$

Note: One millilitre of water at 4°C has a mass of one gram.

Examples



a teaspoon holds 5 mL

See centimetre, volume



a bucket holds 9 L

millimetre

(Symbol: mm)

A unit of length.

$$10 \text{ mm} = 1 \text{ cm}$$

Examples

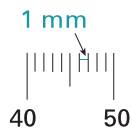
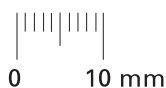

See centimetre, length

million

One thousand thousands: 1 000 000.

See billion

minimum

The smallest or least value.

Example

The minimum temperature in July was 4° C.

See maximum

minuend

A number from which another number is to be subtracted.

Example

$$\begin{array}{r} 29 \\ - 7 \\ \hline 22 \end{array}$$

minuend subtrahend difference

29 is the minuend.

See difference, subtract, subtrahend

minus

(Symbol: −)

(i) Subtract or take away.

Example

Eight minus two is written as $8 - 2$ and means two subtracted from eight.

$$8 - 2 = 6$$

(ii) A symbol to mark negative numbers.

Example

$$-1, -2, -3, -4\dots$$

See integers, negative numbers, subtract

minute

(Symbol: min ')

(i) A measure of time.

$$\text{one minute} = \text{sixty seconds}$$

$$1 \text{ min} = 60 \text{ s}$$

There are sixty minutes in one hour.

(ii) Angle measurement.

$$1' (\text{min}) = \frac{1}{60} (\text{degree})$$

$$1^\circ (\text{degree}) = 60'$$

mirror image

A reflection, as in a mirror.



See image, reflection

mixed number

A whole number and a fraction.

Examples

$$1\frac{1}{2} \quad 3\frac{5}{2}$$

This is another way of writing an improper fraction:

$$\frac{3}{2} = 1\frac{1}{2} \quad \frac{35}{30} = 1\frac{5}{30} = 1\frac{1}{6}$$

See fraction, improper fraction, whole numbers

möbius strip

(moebius)

A surface with only one side. It is made by giving a strip of paper or any other flexible material a half twist and then fastening the ends together.

If a line is drawn down the middle of the strip, it will come back to the starting point, having covered both sides of the strip, without the pencil being lifted.

Example



A thin strip of paper ...



can be given a twist ...



and have the ends ...



joined to make a möbius strip.

mode

In statistics, the score that occurs most often in a collection.

Example

In scores,

1, 1, 2, 4, 4, 6, 6, 6, 6, 7, 7, 7, 8, 10,

6 is the mode.

See average, mean, measures of central tendency, median

model

A three-dimensional representation of an actual or designed object. It may be a physical structure, for example, a model of a cube made from cardboard.

Examples

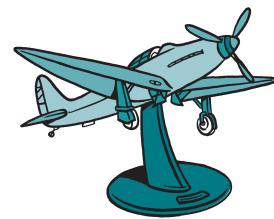
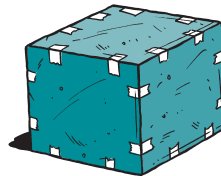

a model of a cube

a model of an aeroplane

See cube, net, scale drawing, three-dimensional

month

A measure of time. There are twelve months in a year. The lengths of different months vary from twenty-eight to thirty-one days.

An easy way to remember the number of days in each month is to learn the following rhyme.

Thirty days has September,
April, June and November.
All the rest have thirty-one,
Except for February alone,
Which has but twenty-eight days clear,
And twenty-nine in each leap year.

See calendar, day, leap year, year

more

Greater in amount.

Example

Four dollars is more than three dollars.

most

The greatest amount.

Example



Jim has twenty cents.

Betty has thirty-five cents.

Peter has thirty cents.

Betty has the most.

A set of base ten blocks consists of:

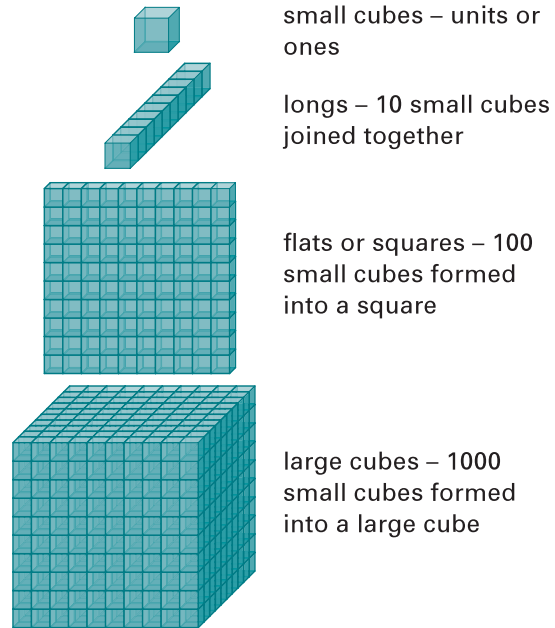

small cubes – units or ones

longs – 10 small cubes joined together

flats or squares – 100 small cubes formed into a square

large cubes – 1000 small cubes formed into a large cube

See base

multilateral

Having many sides.

multiple

A multiple of a given number is any number into which it will divide exactly.

Examples

Multiples of two are 2, 4, 6, 8, 10, 12 ...

Multiples of three are 3, 6, 9, 12, 15, 18 ...

Multiples of four are 4, 8, 12, 16, 20, 24 ...

See division, lowest common multiple

multiplicand

The number that is to be multiplied.

Example

$$\begin{array}{ccccccc} 8 & \times & 7 & = & 56 \\ \uparrow & & \uparrow & & \uparrow \end{array}$$

multiplicand multiplier product

See multiplication, multiplier, product



multibase arithmetic blocks (MAB)

A set of wooden blocks used to give a concrete representation of numbers. They can be used for any base.

Example

Base 3 blocks

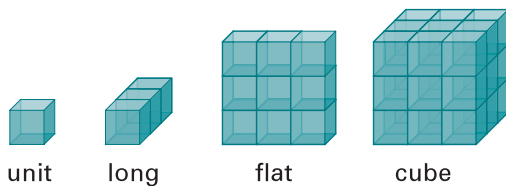

The most commonly used MAB blocks are the base ten blocks.

multiplication

(Symbol: \times)

Multiplication is repeated addition.

Example



- (i) 2 groups of 3, $2 \times 3 = 6$ or
- (ii) 3 multiplied by 2, $3 \times 2 = 6$ or
- (iii) 3 made 2 times bigger.

Sign \times refers to two operations:

- (i) lots of or groups of, and
- (ii) multiplied by.

See addition, operation

multiplication facts

See table

multiplication property of one

When a number is multiplied by one, the product is equal to the original number. This is the multiplication property of one.

Examples

$$7 \times 1 = 7$$

$$1 \times 138 = 138$$

Use of the property is made when a fraction is converted to an equivalent form.

Example

$$\begin{aligned} \frac{2}{3} &= \frac{\square}{12} \\ \frac{2}{3} \times 1 &= \frac{2}{3} \times \frac{4}{4} \\ &= \frac{8}{12} \end{aligned}$$

$\frac{2}{3}$ has been multiplied by one
(or by $\frac{4}{4}$, which is equal to one)

See equivalent fractions

multiplier

The number by which another number is multiplied.

Example

$$\begin{array}{ccccccc} 5 & \times & 7 & = & 35 \\ \uparrow & & \uparrow & & \uparrow \end{array}$$

multiplicand multiplier product

See multiplicand, multiplication, product

multiply

Carry out the process of repeated addition or multiplication.

See addition, multiplication



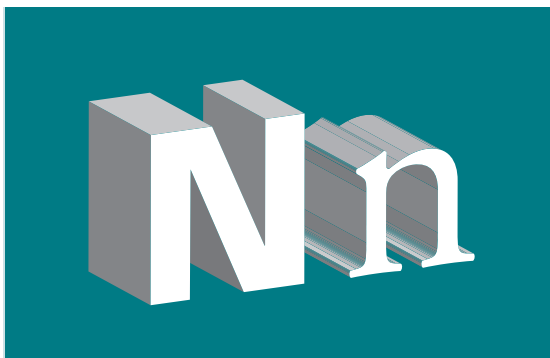

natural number

One of the counting numbers.

Examples

1, 2, 3, 4, 5, 6, 7, 8, 9 ...

See counting number, positive numbers

nautical mile

Unit of length. Used for aviation and maritime purposes. A nautical mile is based on the circumference of the Earth.

One nautical mile equals 1852 metres or 1.852 kilometres.

See knot

negative numbers

A negative number is a number less than zero. Negative numbers are written with the minus sign (-) in front of them.

Examples

-0.1, -0.2, ... -0.9, ... -1, -1.1, ...

-2, ... -2.55 ...

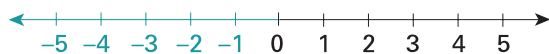

See integers, minus, positive numbers, zero

net

A flat pattern which can be cut out, folded and glued together to make a three-dimensional model of a solid.

Examples

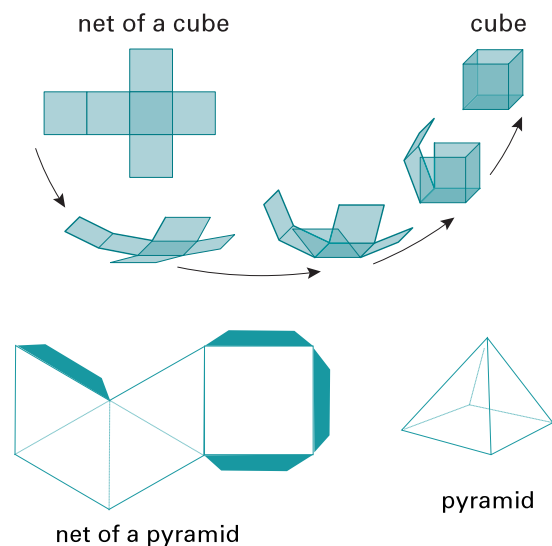

See cube, model, pattern, pyramid

net mass

The mass of an object without packaging.

See gross mass

network

A system of lines or arcs and intersections (nodes) drawn to represent paths and their intersections.

Examples

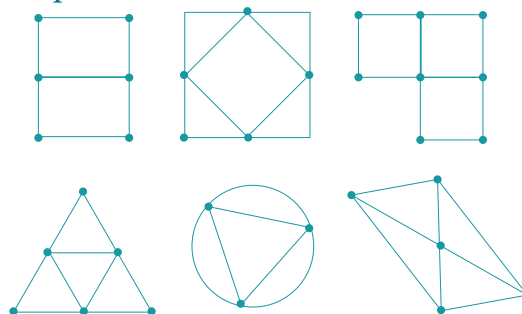

The properties of networks are studied as part of topology.

See intersection, node, topology

node

A point where straight lines or curves intersect. It is also called a junction.

Examples

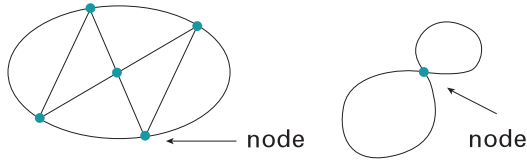

See intersect, network

nonagon

A polygon with nine sides and nine angles.

Examples

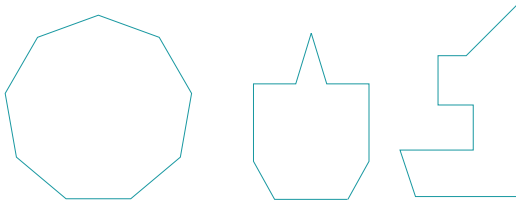

regular nonagon

irregular nonagons

See polygon

none

Nothing. Not one. Not any.

Example

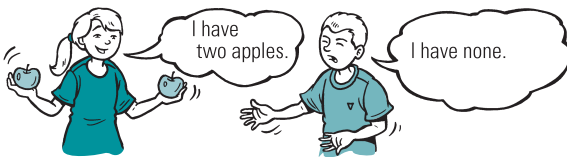

See zero

non-planar figure

A three-dimensional figure. A solid or space figure.

Examples

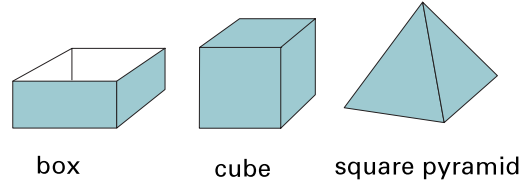

Non-planar means 'not in one plane'.

See planar figure

not equal

(Symbol: \neq)

$$4 \neq 5$$

Four is not equal to five.

See inequality

nothing

(Symbol: 0)

Not one. Having not a thing. Not anything. None. Zero.

number

How many things. A measure of quantity.

Numbers are grouped into many different sets:

- (i) Natural (counting) numbers:
 $1, 2, 3, 4, 5, 6, \dots$
- (ii) Whole numbers:
 $0, 1, 2, 3, 4, 5, \dots$
- (iii) Integers:
 $\dots -4, -3, -2, -1, 0, +1, +2, +3, \dots$
- (iv) Rational numbers, which include fractions and ratios:

$$1 : 3 \quad \frac{1}{100}$$

▼ **number continued...**





Other kinds of numbers include complex, composite, prime, odd, even, square, triangular, rectangular numbers, etc.

See composite number, even number, irrational number, integers, natural number, odd number, prime number, rational number, rectangular numbers, square number, triangle number, whole numbers

number expander

A folded strip of paper used to learn place value.

Example

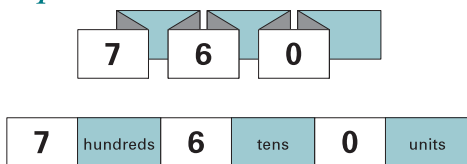

number line

A line on which equally spaced points are marked. The points correspond, in order, to the numbers shown.

Example

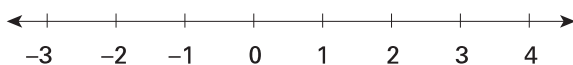

On a number line, the points are labelled from zero and move left of zero for negative numbers and right of zero for positive numbers. The numbers show the distance from zero to each point (using the distance between successive points as one unit).

Operations with numbers can be shown on a number line.

Example

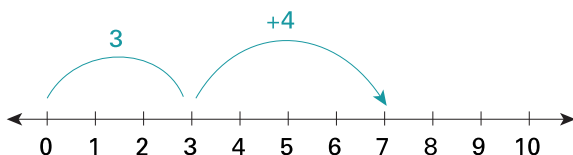

Add three and four.

$$3 + 4 = 7$$

See operation, order

number machine

Number machines can carry out operations such as addition, subtraction, multiplication and division. Calculators and computers are types of number machines.

Example

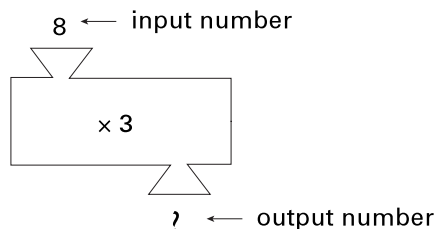

- 1 The number 8 is put into the machine. This is the input number.
- 2 The number is multiplied by three. This is the rule.
- 3 What comes out is the answer.

See calculator, rule

number pattern

See pattern

number sentence

A statement about numbers, usually in symbols rather than words.

Examples

$6 + 7 = 13$ (true)

$4 \neq 9$ (true)

$5 + \square = 9$ (open)

$7 + 9 = 10$ (false)

$3 + 1 < 3 \times 1$ (false)

See open number sentence, symbol

number track

A track, as used in dice games, where the cells are numbered.

Example

14	13	12	11	10	9	8	7	6	5	4
15	30	29	28	FORWARD TO 35	27	26	25	24	3	3
16	31	42	41	40	39	38	37	36	23	2
17	GO BACK TO 29	43	GO BACK TO 34	FINISH			35	GO BACK TO 29	1	1
GO BACK TO 9	GO BACK TO 29	32	GO BACK TO 23	33	34	FORWARD TO 41	GO BACK TO 29	START	START	START
GO BACK TO 9	18	19	FORWARD TO 30	20	GO BACK TO 13	21	22	START	START	START

numeral

A symbol used to represent a number.

Example

5 is the numeral which represents the number five.



5 apples

5 and V (Roman) are numerals for the number five.

See numeration, Roman numerals, symbol

numeration

A system of symbols used to represent numbers. Our system uses the symbols

0, 1, 2, 3, 4, 5, 6, 7, 8 and 9.

See Hindu–Arabic, symbol

numerator

The top number in a fraction. It tells how many parts of the whole there are.

Example

$\frac{3}{4}$ ← numerator

4 ← denominator

In $\frac{3}{4}$ the numerator is 3.

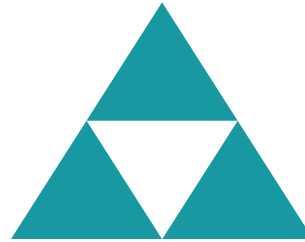

Three out of four equal parts are coloured.

See denominator, fraction



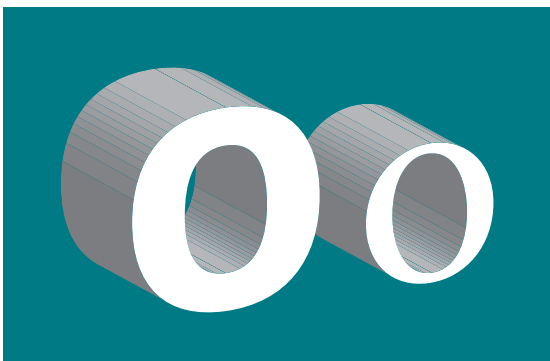

oblique

A slanting line that is neither vertical nor horizontal.

Examples

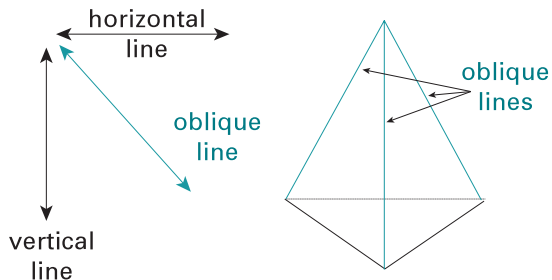

See askew

oblong

Another word for a rectangle or for rectangular.

Example



See rectangle

obtuse angle

An angle bigger than a right angle (90°) but smaller than a straight angle (180°).

Examples

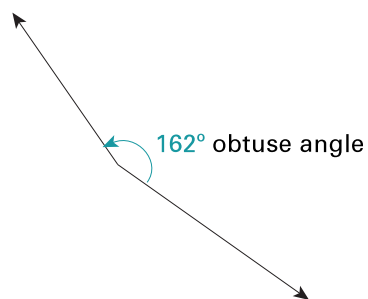
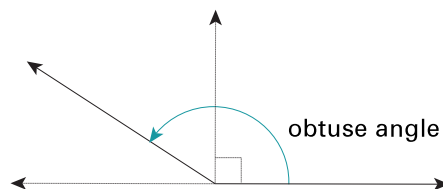

See angle, right angle, straight angle

obtuse triangle

A triangle with one obtuse (larger than 90°) angle.

Examples

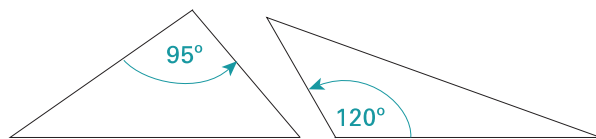

See acute

o'clock

Used when telling time.

Example

We say: six o'clock, ten o'clock ... only when talking about full hours.

Not used when telling hours and minutes: six fifteen, quarter to seven.

octagon

A plane shape (polygon) with eight sides and eight angles.

Examples

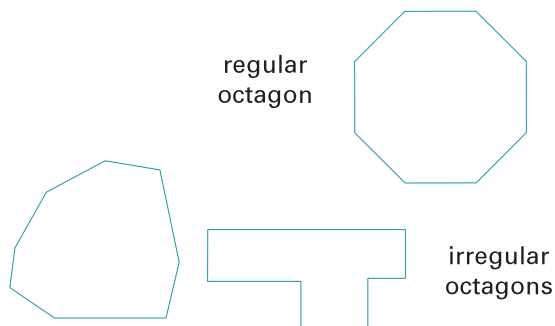

See plane shape, polygon

octahedron

A solid (polyhedron) with eight faces.

A regular octahedron is formed by eight congruent equilateral triangles.

Examples

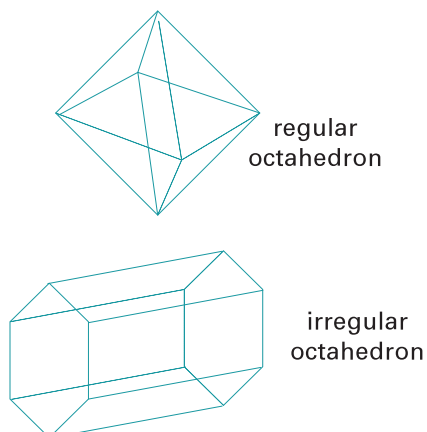

See polyhedron, regular polyhedron

odd number

A number which, when divided by two, leaves a remainder of 1.

All odd numbers finish with one of the digits 1, 3, 5, 7 or 9.

See even number

one-dimensional

(1D)

A figure which has only length is said to be one-dimensional.

Examples

A line has only length; therefore, it has only one dimension.

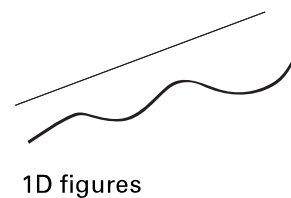

See dimension, plane

one-to-one correspondence

(i) A matching of the objects of two sets.

Examples

Cups and saucers
Straws and bottles
Jumpers and children



(ii) A correspondence between two sets for which each member of each set is paired with only one member of the other set. Arrows are used to show the corresponding objects.

▼ **one-to-one correspondence**
continued...





Example

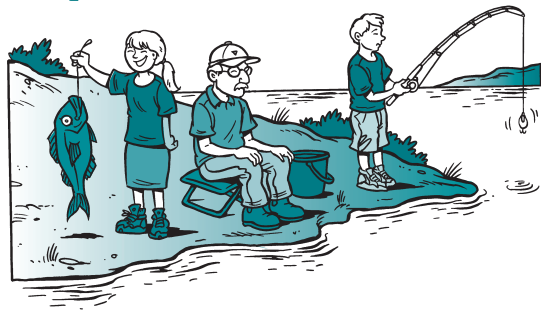

SET A = (Jenny, Dad, Jim)



SET B = (fish, cap, fishing rod)

See arrow diagram, correspondence, many-to-one correspondence

open curve

A curve which has a beginning and an end which do not meet.

Examples

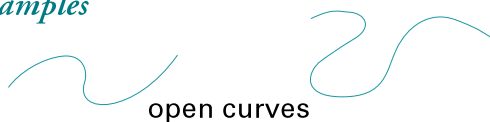

open curves

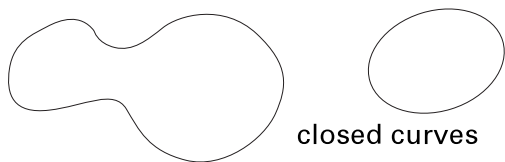

closed curves

See closed curve, curve

open number sentence

A mathematical sentence that contains numbers and variables. It can be an equation or an inequation.

Examples

Equations

$$5 + \triangle = 10$$

$$3 \square - 1 = 25$$

$$\frac{x}{2} - 5 = 7$$

Inequations

$$4a \neq 9$$

$$5x - 5 < 33$$

$$10 - y \geq 28$$

See equation, inequality, inequation, number sentence

operation

There are four arithmetic operations:

Examples

Addition + 2 + 4

Subtraction - 7 - 3

Multiplication \times 10 \times 5

Division \div 8 \div 4

See addition, arithmetic, basic facts, division, multiplication, order of operations, subtraction

operators

The signs used in operations.

+ - \times \div

Examples

$$10 + 2 \quad 7 \times 3 \quad 8 - 4 \quad 18 \div 6$$

See operation

opposite numbers

Numbers that add up to zero.

Example

$$-5 + 5 = 0$$

The opposite to -5 is 5;

the opposite to 320 is -320.

order

- (i) To order means to arrange in a pattern or a sequence.
- (ii) Order means a pattern or a sequence.
- (iii) Order of numbers on a number line.

See ascending order, descending order, number line, pattern, sequence

ordered pair

Two numbers (called x -coordinate and y -coordinate) written in a certain order.

Ordered pairs are usually written between brackets.

Example

(5, 3)

The x -coordinate is always written first.

The ordered pair \square (3, 5) is not the same as the ordered pair \circ (5, 3).

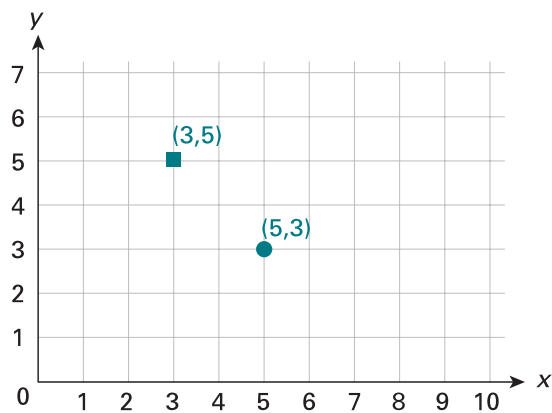

See axis, brackets, coordinates

ordering

Placement according to size, colour, numerical value, etc.

Example

The rabbits have been ordered from smallest to largest.

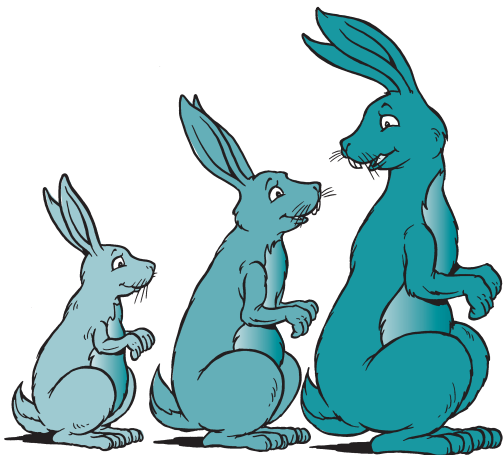

order of operations

Used when evaluating complex number sentences.

- (i) Number sentences with grouping symbols.

When grouping symbols are used, working is done from inside the brackets out.

Example

$$\begin{aligned} & 5\{3 - [(4 \times 9) - (20 - 4)] + 19\} \\ &= 5\{3 - [36 - 16] + 19\} \\ &= 5\{3 - 20 + 19\} \\ &= 5 \times 2 \\ &= 10 \end{aligned}$$

- (ii) When no grouping symbols are used, starting from the left do all multiplications and divisions, then again from the left, do all additions and subtractions.

Example

$$\begin{aligned} & 48 \div 3 + 2 - 4 \times 3 \\ & (48 \div 3) + 2 - (4 \times 3) \quad \text{Insert brackets} \\ & \quad \quad \quad \quad \quad \quad \quad \quad \quad \quad \quad \quad \quad \quad \quad \quad \quad \quad \quad \text{around multiplication} \\ & \quad \quad \quad \quad \quad \quad \quad \quad \quad \quad \quad \quad \quad \quad \quad \quad \quad \quad \quad \text{and division.} \\ &= 16 + 2 - 12 \\ &= 18 - 12 \\ &= 6 \end{aligned}$$

Do addition first, then subtraction.

- (iii) Sometimes 'of' is used.

Example

$$\begin{aligned} & 5(3 + 8) - \frac{1}{2} \text{ of } 10 \\ &= 5 \times 11 - \left(\frac{1}{2} \times 10\right) \\ &= 55 - 5 \\ &= 50 \end{aligned}$$

Note: To remember the order of operations, do: Brackets first, Of, Division, Multiplication, Addition, Subtraction.

Think : BODMAS.

See braces, brackets, operation, parentheses

ordinal number

A number which indicates position.

Examples

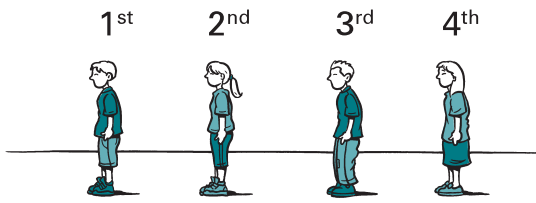

See cardinal number

ordinate

The y -axis in a Cartesian coordinate system is also called the ordinate.

See axis, coordinates

origin

A point at which something begins.

Example

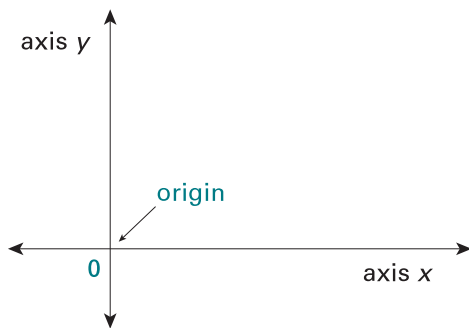

The coordinates of the origin are $(0, 0)$.

The point where axes x and y intersect is called the origin and is marked 0.

See axis, coordinates, intersect, ordered pair

outcome

The result of an experiment or trial involving the unknown.

Example

In tossing a coin, there are two possible outcomes, either heads or tails.

output

See number machine

oval

- (i) An egg-shaped figure which is symmetrical about one axis. One end is more pointed than the other.

Example

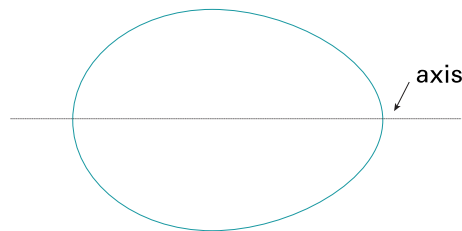

- (ii) Another word for an ellipse, which is symmetrical about two axes.

Example

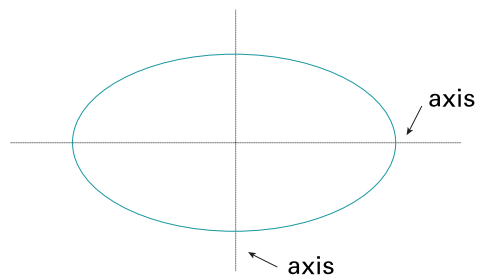

See axis, ellipse, symmetry

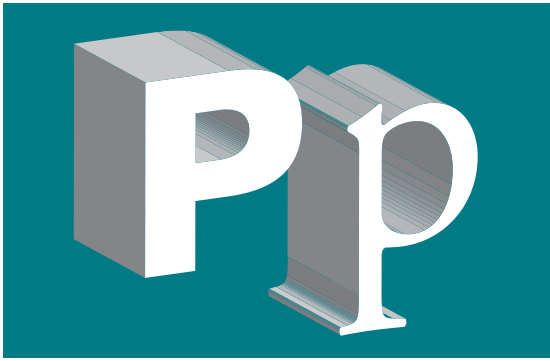

p.a.

Per annum. Per year.

Example

The bank charges 7% interest p.a.

pace

The distance between your feet when you take a step. It is measured from heel to heel. It is used as an arbitrary unit for estimating distances.

Example

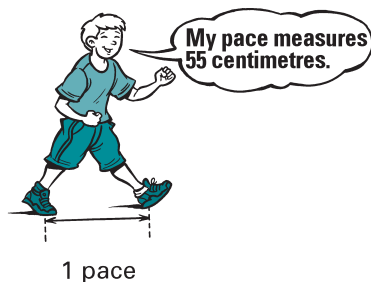

See arbitrary unit, distance, estimate

pair

Two things that belong together.

Example



a pair of socks

palindrome

A number or word that reads the same forward as backward.

Examples

1991 19.9.1991 madam

pantograph

An instrument for tracing a drawing, map or a picture. Also used for the enlargement or reduction of an original.

Example

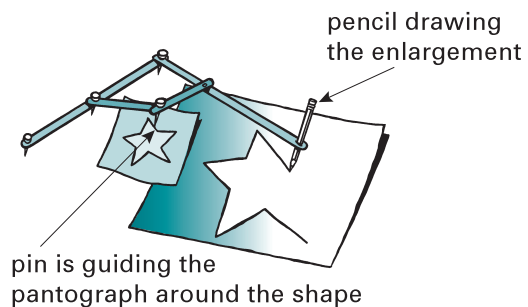

See enlargement

parabola

A parabola is a conic section made by the intersection of a right circular cone and a plane. It can also be defined as a locus of points that are equidistant from a given point (the focus) and a fixed line (the directrix).

Example

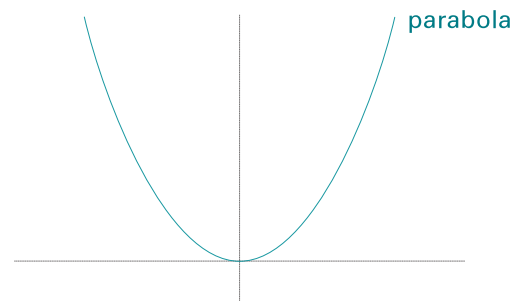

See conic section, equidistant



parallelepiped

A prism, made of parallelograms.

Example

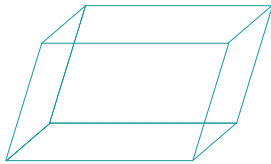

See parallelogram, prism

parallel lines

(Symbols:  )

Two or more lines that go in exactly the same direction. Parallel lines always remain the same distance apart. They never meet.

Example

Train lines are parallel.

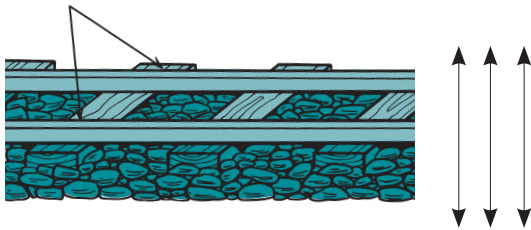

When parallel lines are crossed by a transversal, pairs of angles are formed. They have special properties:

- 1 corresponding angles (make F-shape). They are equal.

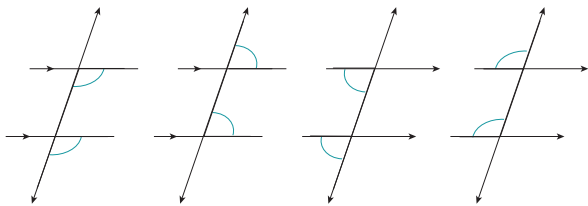

- 2 alternate angles (make Z-shape). They are equal.

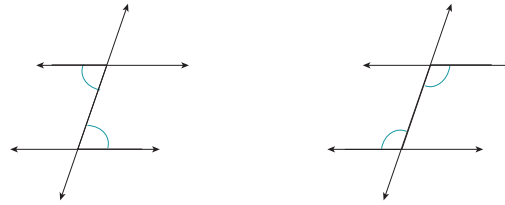

- 3 cointerior angles (make U-shape). They add up to 180°.

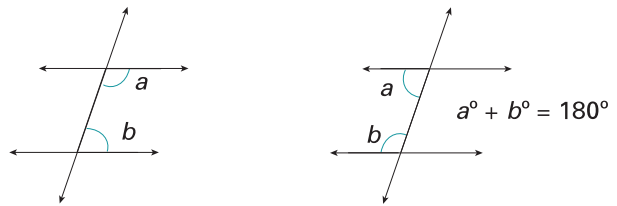



See transversal, vertically opposite angles

parallelogram

A four-sided figure (quadrilateral) in which both pairs of opposite sides are parallel and equal, and the opposite angles are equal.

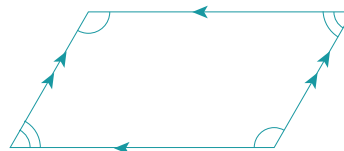
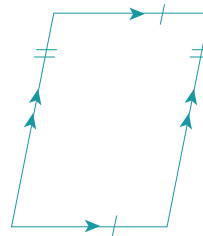
Examples



The arrow marks   show which pairs of lines are parallel.

A right-angled parallelogram is a rectangle.

Example



See parallel lines, quadrilateral, rectangle

parentheses

Word for ordinary brackets used for grouping numbers together.

Example

()	$(2 + 3) - (5 + 2)$
parenthesis,	$= 5 - 7$
or ordinary	$= -2$
brackets	

See braces, brackets, order of operations

partition

See division

Pascal's triangle

Used in probability.

			1					
		1		1				
	1		2		1			
	1	3		3		1		
	1	4	6		4	1		
	1	5	10	10	5	1		
	1	6	15	20	15	6	1	
	1	7	21	35	35	21	7	1

Notice that after the second line the new numbers are made by adding the numbers in the previous line.

path

A connected set of points.

The route or line along which a person or object moves.

Example

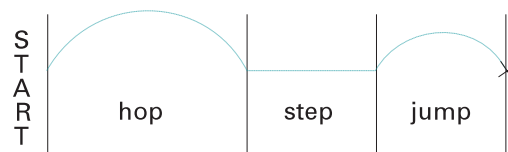

the path of my hop-step-jump

pattern

A repeated design or arrangement using shapes, lines, colours, numbers, etc.

Examples

(i) Shape pattern

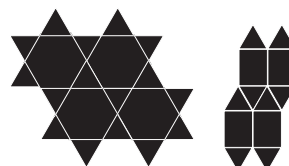

(ii) Colour pattern



(iii) A 'number pattern' is a sequence of numbers formed by following a 'rule':

1, 4, 7, 10 ... (rule: add three)

16, 8, 4, 2, 1, $\frac{1}{2}$, $\frac{1}{4}$, $\frac{1}{8}$...
(rule: divide by two)

See rule, sequence



pattern blocks

Sets of plastic, wood or cardboard shapes in the form of triangles, squares, parallelograms, hexagons, etc.

Examples

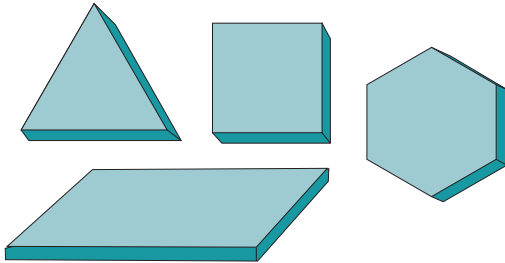

pegboard

Plastic or wooden board containing holes in which pegs can be placed.

Example

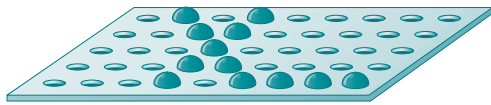

Coloured pegs are used to represent numbers, patterns or shapes.



pendulum

A small heavy object attached to a string suspended from a fixed point.

Example

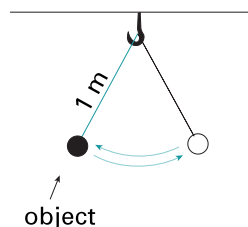

If the string is one metre in length, then it takes about one second to make a single complete swing, over and back.

See [second](#)

pentagon

A shape (polygon) with five straight sides and five angles.

Examples

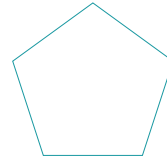

regular pentagon

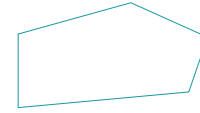

irregular pentagon

See [polygon](#)

per annum

(p.a.)

Yearly, per year.

per cent (percentage)

(Symbol: %)

A number out of one hundred.

Example

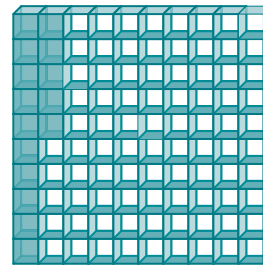

This is a 'hundred square'. Fifteen out of the hundred little squares have been coloured in. They represent:

$$\frac{15}{100} = 15\% = 0.15$$

↑ ↑ ↑
 fraction percentage decimal fraction

See [decimal fraction](#), [fraction](#)

perimeter

The distance around a closed shape, or the length of its boundary.

Example

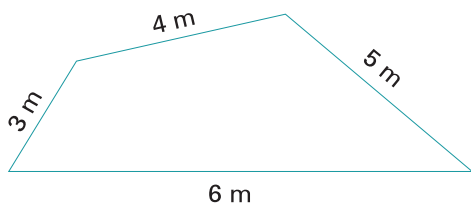

To find the perimeter of a shape, add the lengths of all its sides.

The perimeter is:

$$3\text{ m} + 4\text{ m} + 5\text{ m} + 6\text{ m} = 18\text{ m}$$

See [boundary](#), [circumference](#)

permutation

An ordered arrangement or sequence of a group of objects.

Example

Three shapes 

can be arranged in six different ways, or have six permutations.

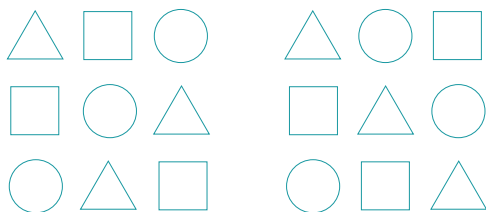

The order in which the shapes are arranged is important in a permutation. When the order is not important, the arrangement is called a combination.

See [combination](#)

perpendicular

Forming a right angle.

(i) Perpendicular height.

The line segment drawn from the vertex (top) of a figure to the opposite side at a 90° angle.

Examples

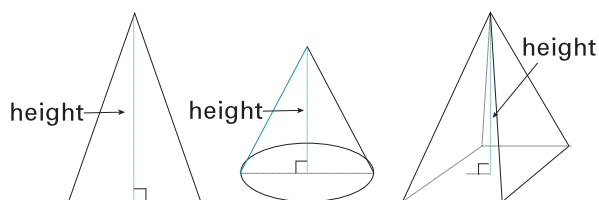

The height of a triangle, cone or pyramid

(ii) Perpendicular lines.

Lines which intersect to make right angles.

Examples



See [altitude](#), [apex](#), [cone](#), [line segment](#), [pyramid](#), [triangle](#), [vertex](#)

perspective

When drawing on paper, we can show depth by drawing all parallel lines running into one or several points on the horizon. These points are called vanishing points. The drawing looks as if it is three-dimensional. We say it has perspective.

Example



See [converging lines](#)



pi

(Symbol: π)

The ratio of the circumference of a circle to its diameter.

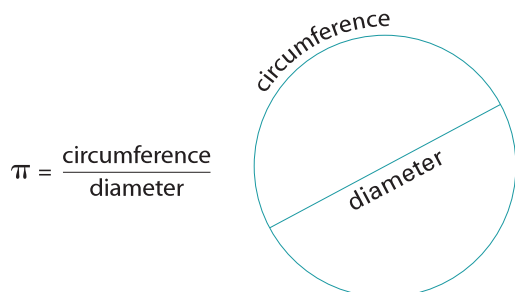

$$\pi = \frac{\text{circumference}}{\text{diameter}}$$

The approximate value of π is 3.14.

The exact value cannot be worked out.

See chronological order, circle, circumference, diameter, infinite decimal, radius

pictograph

(pictogram)

A graph drawn with pictures that represent the real objects.

Example

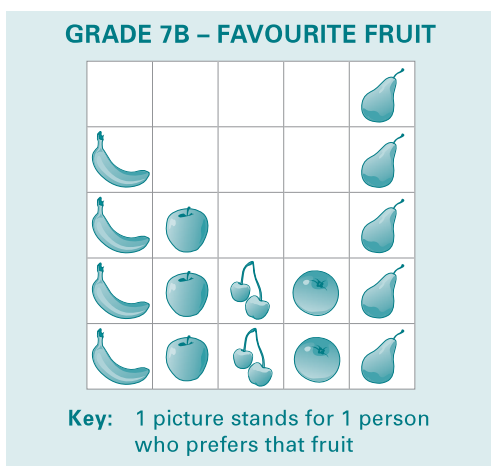

A pictograph must have a heading and a key.

See graph

picture graph

Another name for a pictograph.

pie graph

(pie chart)

A circle graph. Also called a sector graph.

Example

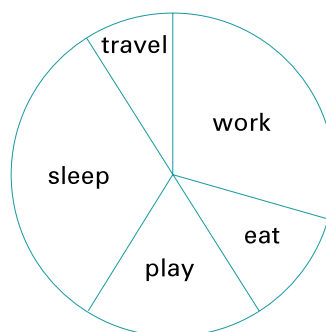

How Linda spends a day

See graph

place holder

- (i) A symbol which holds the place for an unknown number.

Examples

In $w + 3 = 7$, w is the place holder.

In $\square - 6 = 10$, \square is the place holder.

- (ii) Zero, when used with other digits, is used as a place holder.

Example

6800

The zero in place of units and tens helps us to see that the numeral 8 means eight hundreds, the numeral 6 means six thousand and that there are no units and no tens.

See digit, equation, variable

place value

The value of each digit in a number depends on its place or position in that number.

Examples

hundreds	tens	ones
4	8	6
	1	8
8	2	3

In the number 486 the value of digit 8 is 80 (eight tens).

In the number 18 the value of digit 8 is 8 (eight units).

In the number 823 the value of digit 8 is 800 (eight hundreds).

See decimal place-value system, digit, value

plan

(i) To prepare ahead of time.

Example

Plan for a holiday.

(ii) A diagram of an object as seen from above.

Example

3A CLASSROOM FLOOR PLAN

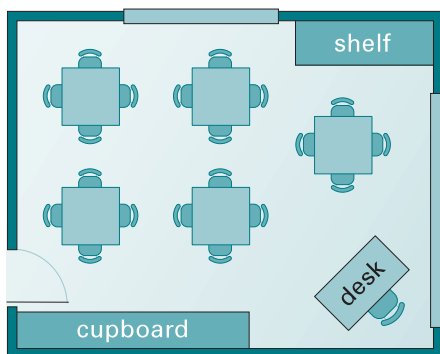

See cross-section of a solid, diagram, front view, side view

planar figure

A two-dimensional shape, such as a triangle. Also called a plane figure or plane shape.

Examples

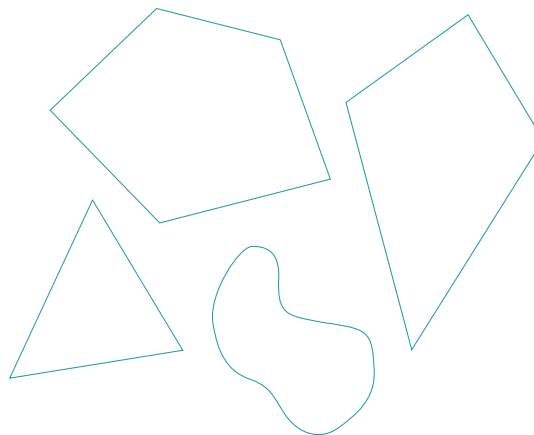

See plane shape, triangle, two-dimensional

plane

A flat surface, like the floor of a house or a wall.

A plane extends infinitely in all directions.

Two-dimensional objects are called plane shapes or planar figures because they can be drawn in one plane.

Example

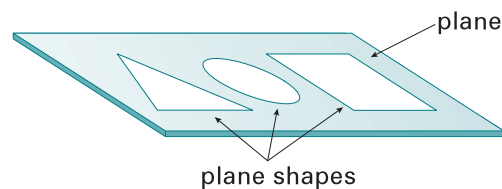

See dimension, infinite, planar figure, two-dimensional



plane shape

A plane shape is a closed shape that can be drawn on a flat surface.

Examples

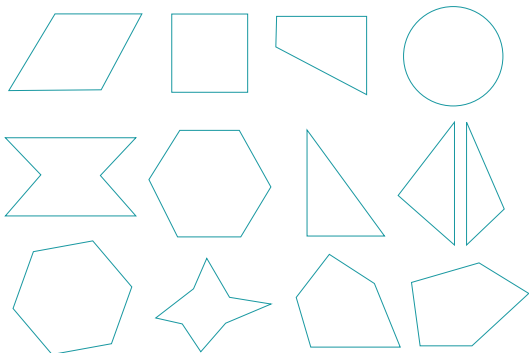

See non-planar figure, planar figure

platonic solids

See regular polyhedron

plus

(Symbol: +)

The name of the symbol that means addition.

Example

$$4 + 6 = 10$$

See addition



p.m.

(post meridiem)

The time from immediately after midday until immediately before midnight.

The abbreviation p.m. is used only with 12-hour time.

Example

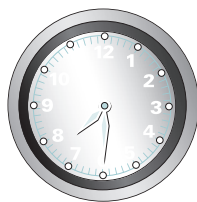

It is evening.

The time is half past seven.

It is 7.30 p.m.

See a.m.

point

- (i) Small dot on a surface. It has no dimension.

. P

The dot shows where the point P is.

- (ii) The dot, called the decimal point, shows that 4 means four dollars and 50 is fifty cents.

\$4.50

See decimal point

polygon

A plane shape which has three or more straight sides; for example, a triangle, quadrilateral, pentagon or hexagon.

Examples

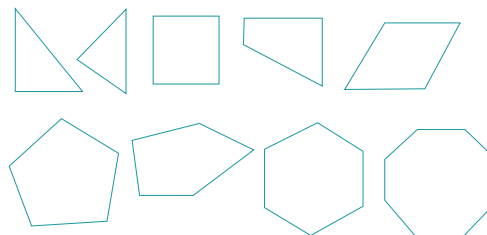

See closed shape, hexagon, irregular polygon, line segment, octagon, pentagon, quadrilateral, regular polygon, triangle

polyhedron

(Plural: polyhedrons or polyhedra)

A three-dimensional shape with plane faces.

Examples

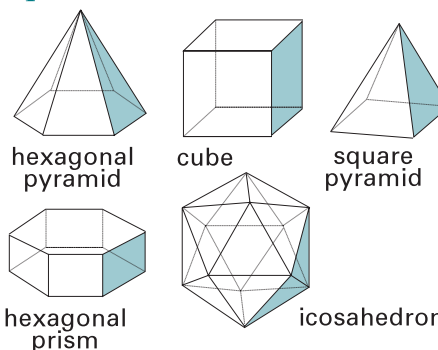

hexagonal pyramid

cube

square pyramid

hexagonal prism

icosahedron

See cube, dodecahedron, icosahedron, prism, pyramid, regular polyhedron

polyomino

A plane shape made of squares of the same size, each square being connected to at least one of the others by a common edge.

Examples

domino – two squares



triomino – three squares

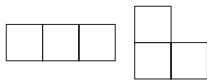

tetromino – four squares

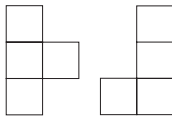

pentomino – five squares

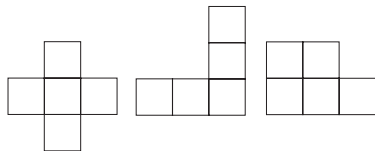

See planar figure

position

Describes the place where something is.

Examples

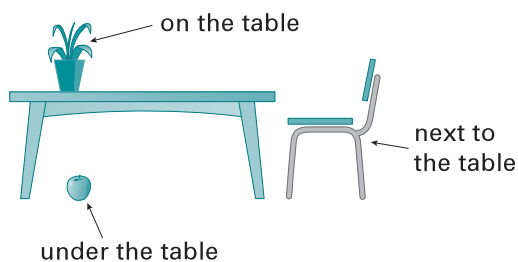

On, under, above, behind, in front of, between, next to, outside, etc.

See coordinates, ordered pair

positive numbers

Numbers greater than zero. We sometimes write the plus sign (+) in front of them.

Examples

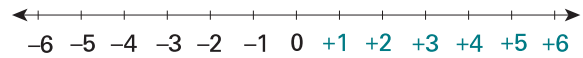

+4, +5, +6 ...+937, +938 ...

See integers, negative numbers, plus, zero

power of a number

In 2^4 the power is 4. It is also called the index.

It means $2 \times 2 \times 2 \times 2 = 16$

Say: two to the power of four.

When the power is zero, the value is one.

$10^0 = 1$ $1000^0 = 1$

See cubed number, index, index notation, square number, zero power

prediction

In mathematics we can predict or estimate possible answers.

See estimate, probability



prefix

A word before a unit, showing us how large the measure is.

Example

One millimetre means one thousandth of a metre.

See section Prefixes tables on pages 153–4

prime factor of a number

A prime number that will divide exactly into a given number.

Example

2, 3 and 5 are the prime factors of thirty. (10 is a factor of thirty, but not a prime factor.)

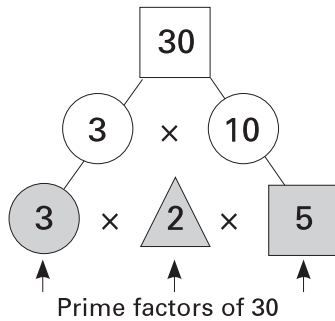

See factor tree, factors, prime number

prime number

A counting number that can only be divided by one and itself.

Examples

2, 3, 5, 7, 11, 13, 17 ...

The factors of two are 2 and 1.

The factors of five are 5 and 1.

A prime number has only two factors, itself and 1.

Note: Number 1 is usually considered to be neither prime nor composite.

See composite number, counting number, factors

principal

The amount borrowed or invested is called the principal.

Example

Joe borrowed \$100 from a bank. The principal is \$100.

See interest, interest rate

prism

A solid figure with two faces that are parallel and the same in size and shape. They can be any polygon.

Examples

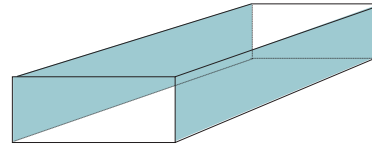

rectangular prism

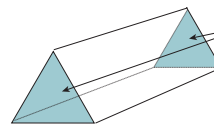

These two faces are parallel and the same shape and size.

triangular prism

All cuboids are prisms.

See cuboid, face, parallel lines, polygon, polyhedron, prism, three-dimensional

probability

The likelihood of an event happening.

Example

If a coin is tossed, the probability of getting tails is $\frac{1}{2}$.

See chance event, equally likely

problem solving

Using your understanding and knowledge of mathematical concepts and principles to find a solution in a new or unfamiliar situation.

product

The answer to a multiplication problem.

Example

$$\begin{array}{ccccccc} 3 & \times & 2 & = & 6 & & \\ \uparrow & & \uparrow & & \uparrow & & \end{array}$$

multiplicand multiplier product

Six is the product.

See associative property of multiplication, commutative property of multiplication, multiplicand, multiplication, multiplier

profit

If the selling price is higher than the cost price the seller makes a profit.

Example

A car dealer buys a car for \$10 000 and sells the same car for \$12 000. As the selling price is higher than the buying price, the dealer makes a profit of \$2000.

See cost price, loss, selling price

progression

A sequence of numbers following a given rule. The numbers in a progression increase or decrease in a constant way.

- (i) If the rule is 'add a number', it is called an *arithmetic progression*.

Examples

Rule: add 3 1, 4, 7, 10, 13, 16, ...

Rule: subtract 2 21, 19, 17, 15, 13, 11, ...

- (ii) If the rule is 'multiply by a number', it is called a *geometric progression*.

Examples

Rule: multiply by 4 1, 4, 16, 64, 256, ...

Rule: divide by 2 12, 6, 3, 1.5, 0.75, ...

See decrease, increase, sequence

projection

The transformation of one shape or picture to another.

Example

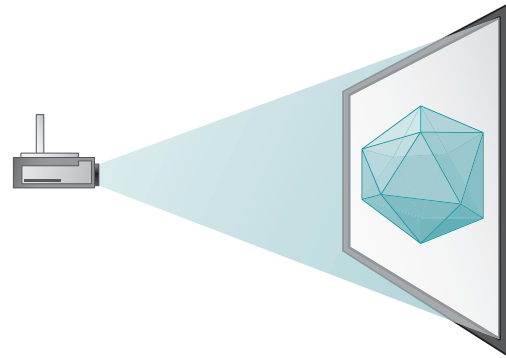

Projecting a picture onto a screen

See transformation

pronumeral

Another word for the symbol representing an unknown value in an equation. The pronumeral stands for a particular value.

Examples

$$2a = 6 \qquad 7 - x = 5 \qquad 12 \times \square = 24$$

$$a = 3 \qquad x = 2 \qquad \square = 2$$

a , x and \square are pronumerals.

See algebraic expression, symbol, variable



proper fraction

A fraction where the numerator is less than the denominator.

Examples

$$\frac{4}{5}$$

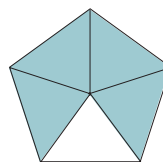

$$\frac{36}{100}$$

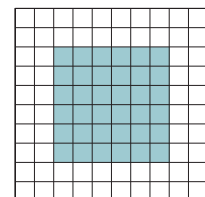

See denominator, fraction, improper fraction, numerator, simple fraction

property

A characteristic of an object.

See attribute, classification, classify

proportion

A statement of equality between two ratios.

(i) Direct proportion.

When a relation between two variables remains constant, they are said to be in direct proportion.

Example

Mary reads three pages of a book every ten minutes.

The ratio $\frac{\text{pages}}{\text{time}}$ is constant.

$$\frac{3 \text{ pages}}{10 \text{ min}} = \frac{6 \text{ pages}}{20 \text{ min}} = \frac{9 \text{ pages}}{30 \text{ min}} = \frac{12 \text{ pages}}{40 \text{ min}} \dots$$

(ii) Indirect (or inverse) proportion.

When one variable is multiplied by a number and the other variable is divided by the same number, they are said to be in indirect proportion.

Example

It takes four hours for one person to mow the lawn.

It takes two hours for two people to mow the lawn.

Number of people	1	2	3	4	8
Time in hours	4	2	$1\frac{1}{3}$	1	$\frac{1}{2}$

See inverse, ratio, variable

protractor

An instrument used to measure and draw angles.

Example

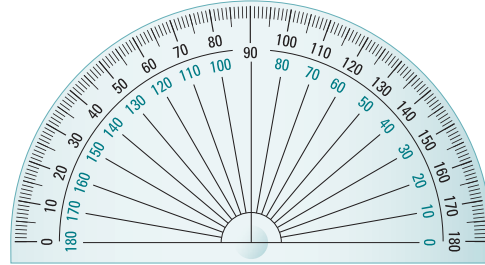

prove

Test correctness of calculation.

pyramid

A solid (3D shape) which has a polygon for a base and all the other faces are triangles.

Example

This pyramid has a square base and the other faces are congruent triangles.

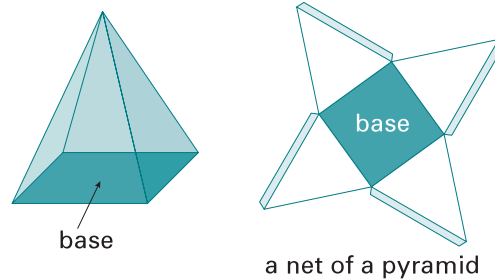

A tetrahedron is a pyramid with a triangular base.

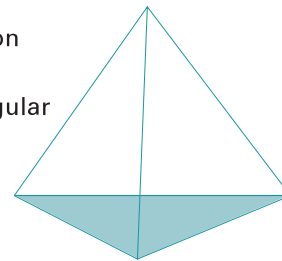

The base of a pyramid can be any polygon.

See apex, base, face, isosceles triangle, net, polygon, solid, tetrahedron, vertex



Pythagoras' theorem

In any right-angled triangle, the square of the hypotenuse is equal to the sum of the squares of the sides.

Example

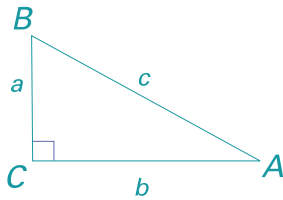

$$c^2 = a^2 + b^2$$

$$a^2 = c^2 - b^2$$

$$b^2 = c^2 - a^2$$

$$c^2 = a^2 + b^2$$

$$5^2 = 3^2 + 4^2$$

$$25 = 9 + 16$$

$$25 = 25$$

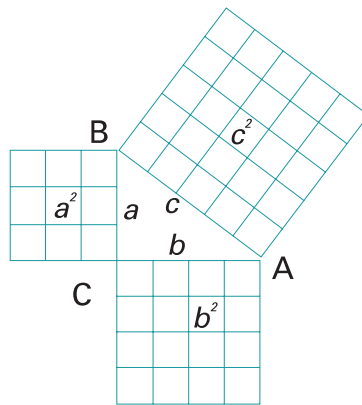

$$a = \sqrt{c^2 - b^2}$$

$$b = \sqrt{c^2 - a^2}$$

$$c = \sqrt{a^2 + b^2}$$

See right-angled triangle





quadrilateral

A plane shape with four sides and four angles.

Example

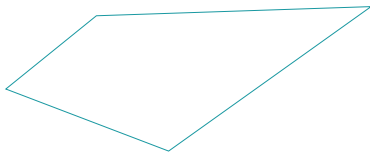

Some special quadrilaterals are:

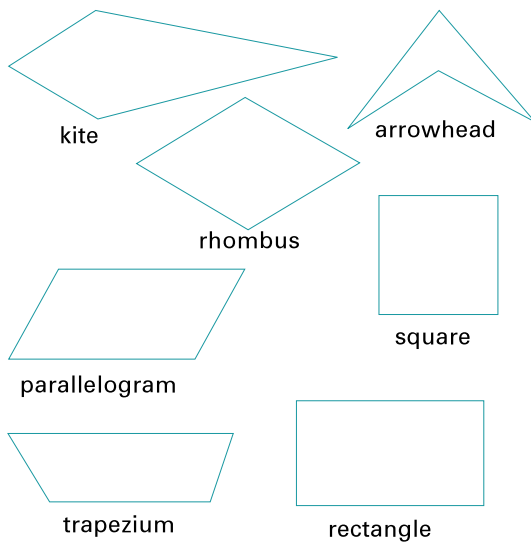

See kite, parallelogram, planar figure, rectangle, rhombus, square, trapezium

quadrant

(i) A quarter of the circumference of a circle.

Example

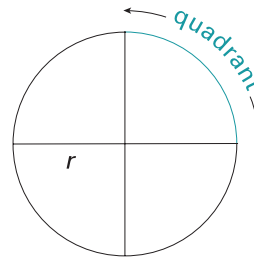

(ii) A plane figure made by two radii of a circle at a 90° angle and the arc cut off by them.

Example

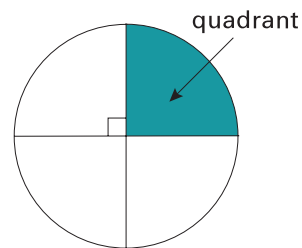

(iii) In coordinate geometry we use the space between the x -axis and y -axis. We can extend the x -axis and the y -axis so that all four quadrants of the number plane can be seen. Quadrants are numbered in an anticlockwise direction.

Example

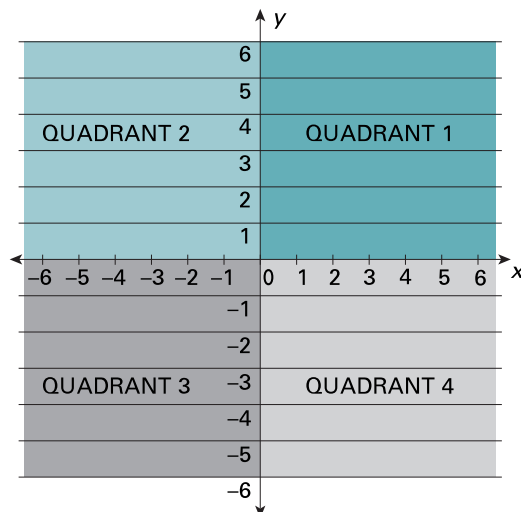

See arc, coordinates, ordered pair, radius

quadruple

Increase the amount four times.

Example

quadruple \$20 means

$$4 \times \$20 = \$80$$

See double, treble

quantity

The amount or number of something.

Example

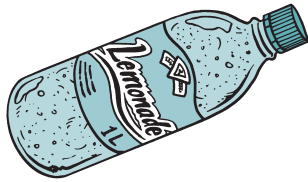

The quantity of lemonade in the bottle is one litre.

quarter

One of four equal parts.

Examples

$\frac{1}{4}$ is shaded

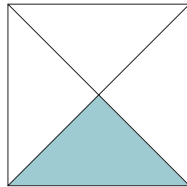

Quarter of the boys are sitting.

quotient

The answer to a division problem.

Example

$$\begin{array}{ccccccc} 10 & \div & 2 & = & 5 & & \\ \uparrow & & \uparrow & & \uparrow & & \\ \text{dividend} & & \text{divisor} & & \text{quotient} & & \end{array}$$

Five is the quotient.

See dividend, division, divisor

quotation

See division



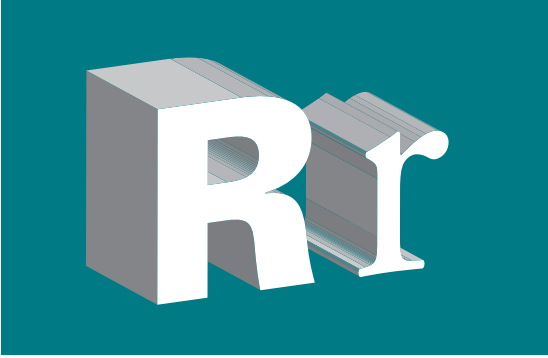

radian

The radian is the angle at the centre of a circle (approximately 57.3°), when the length of the arc is equal to the radius.

Example

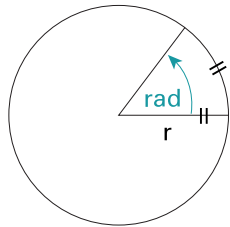

See arc, radius

radiant point

A point from which rays or radii start.

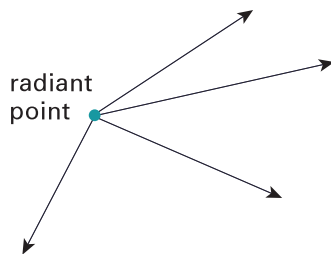

See ray

radius

(Plural: radii)

- (i) The distance from the centre of a circle to its circumference (or from the centre to the surface of a sphere).

Example

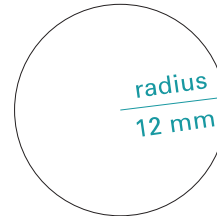

- (ii) The line segment joining the centre and a point of the circle (like the spoke of a wheel) or a line segment joining the centre of a sphere to a point on its surface.

Example



See circle, circumference, diameter, line segment, sphere

random sample

A term in statistics meaning a part or portion which is chosen to represent the whole.

Example

A bag with twenty black and twenty white balls. A random sample may be three white and two black balls.



See statistics

range

The range is the difference between the largest and the smallest number in a set.

Example

{1, 2, 3, 4, 5, 6}

The smallest number is 1.

The largest number is 6.

The range is $6 - 1 = 5$.

rate

- (i) The comparison between two quantities, which may be of different things.

Example

Sixty kilometres per hour (60 km/h) is the rate of travel.

- (ii) The exchange rate is the comparison of values of money.

Example

US\$1 = A\$0.67

See comparison

ratio

(Symbol: :)

A comparison of two quantities.

We express one quantity as a fraction of the other.

Example

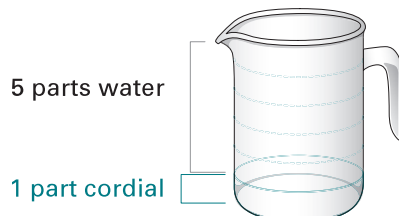

To make a jug of cordial, mix the cordial and water in the ratio of 1 : 5. This means that you mix one part of cordial to five parts of water.

The order of the numbers is important:

$1 : 5 \neq 5 : 1$.

See comparison

rational number

A number that can be expressed as a fraction or ratio of integers.

Examples

$$\frac{3}{4} \quad 0.5 = \frac{1}{2} \quad 8 = \frac{8}{1}$$

All rational numbers can be represented by either:

- (i) decimal numbers that terminate

Examples

$$\frac{3}{4} = 0.75 \quad \frac{1}{8} = 0.125$$

- (ii) non-terminating, repeating decimals.

Examples

$$\frac{2}{3} = 0.\dot{6} \quad \frac{-4}{11} = -0.\dot{3}\dot{6}$$

See fraction, ratio, recurring decimal

ray

A line that has a starting point but no end. It extends in one direction only.

Examples

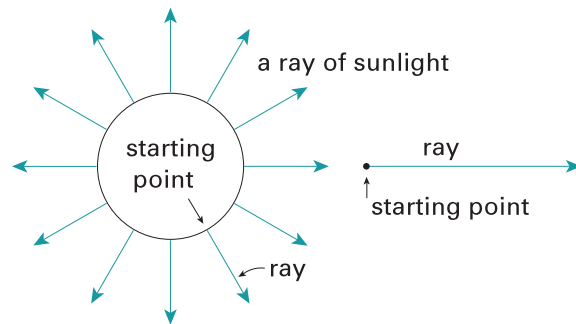

See angle, line, line segment, radiant point

real number

The set of real numbers is made up of all rational and irrational numbers.

See irrational number, rational number

reciprocal

The reciprocal of a fraction is the fraction obtained by interchanging the numerator and denominator.

Example



- (i) Since we can write 4 as $\frac{4}{1}$ the reciprocal of 4 is $\frac{1}{4}$.
- (ii) Reciprocal of $\frac{2}{3}$ is $\frac{3}{2}$ or $1\frac{1}{2}$.

rectangle

A quadrilateral with two pairs of equal and parallel sides, and four right angles.

Example

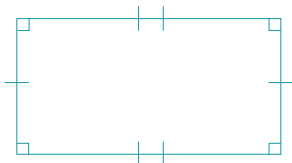

A rectangle is sometimes called an oblong.
See parallel lines, quadrilateral, right angle



rectangular numbers

Numbers that can be represented by dots arranged in a rectangle.

Examples

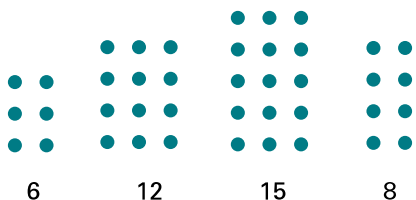

rectangular prism

A polyhedron whose base is a rectangle. Another name for a cuboid.

Examples

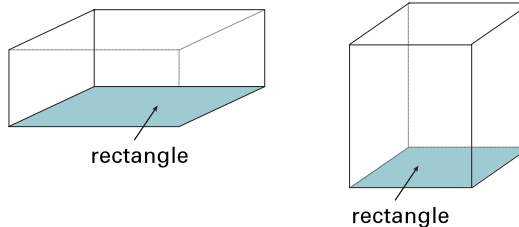

Most boxes are rectangular prisms.

See cuboid

recurring decimal

A decimal fraction in which one or more digits are repeated indefinitely.

Examples

- (i) $\frac{1}{3} = 0.33333 \dots = 0.\dot{3}$
It is written $0.\dot{3}$. The dot shows that the digit is repeated.
- (ii) $0.1\dot{7}$
These dots show that the digits 1 and 7 are repeated.
 $0.1717171717 \dots$
- (iii) $\frac{1}{7} = 0.142857142857 \dots$
It is written either as $0.\dot{1}4285\dot{7}$ or 0.142857 to show the repeated digits.

See decimal fraction, digit, rational number, terminating decimal

reduce

- (i) Simplify. Express a fraction in its simplest form.

Example

$\frac{5}{30}$ can be reduced to $\frac{1}{6}$

- (ii) Make smaller.

See cancelling, enlargement, fraction, transformation

reflection

Being reflected. Reflecting.

Examples

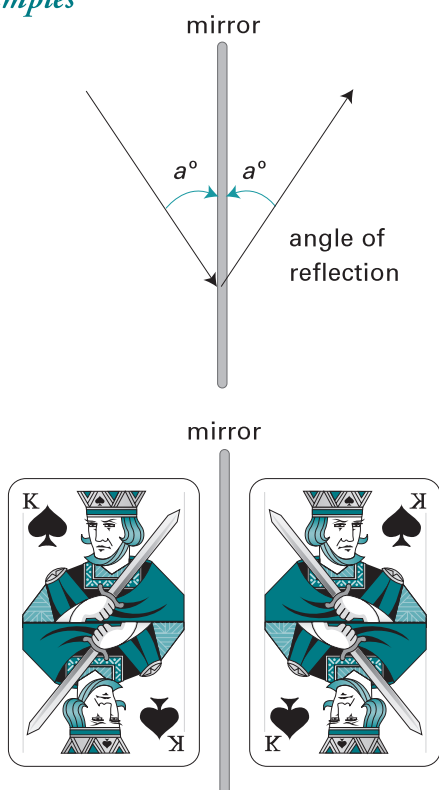

See flip, mirror image

reflex angle

An angle greater than a straight angle (180°) but less than a revolution (360°).

Examples

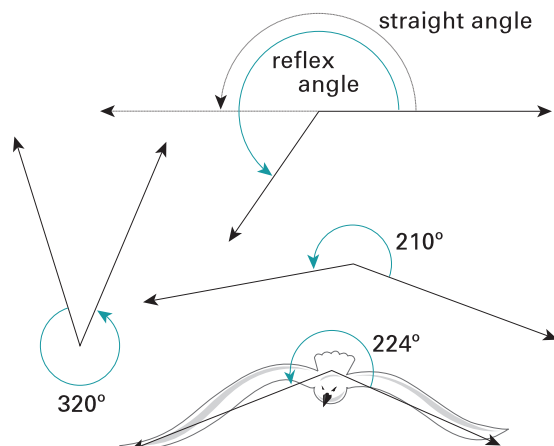

See angle, revolution, straight angle

region

(i) Plane region.

All the points inside a simple closed shape together with all of the points on the boundary of the shape.

Example

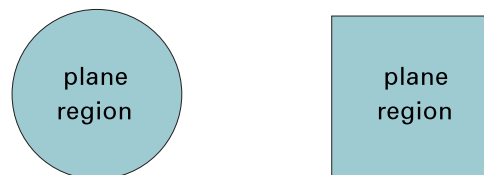

(ii) Solid region.

All the points inside a closed surface together with all the points on the surface.

Example

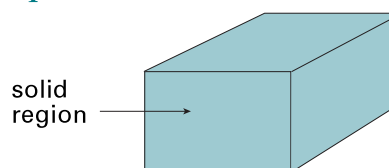

See boundary, plane, solid, surface

regroup

Exchange.

Examples

(i) Twelve unit blocks can be regrouped (exchanged) for one long (10) and two units.

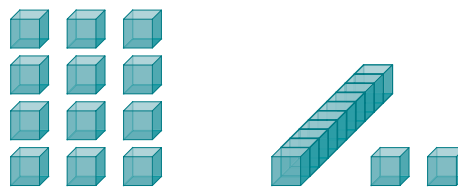

(ii) Before subtracting fifteen, the eight tens and two units have been regrouped into seven tens and twelve units.

$$\begin{array}{r} 7 \overline{)82}^{12} \\ - 15 \\ \hline 67 \end{array}$$

See carrying, group, multibase arithmetic blocks (MAB)

regular polygon

A polygon is regular if its sides are equal in length and its angles are equal in size.

Some common regular polygons are:



equilateral triangle

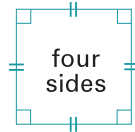

square

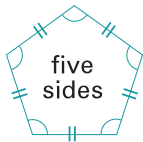

regular pentagon

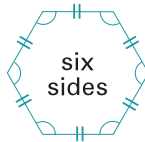

regular hexagon

See equilateral triangle, hexagon, irregular polygon, pentagon

regular polyhedron

A polyhedron whose faces are congruent regular polygons that are exactly the same in shape and size. Internal angles are also the same in size. Regular polyhedrons are also called platonic solids.

There are only five regular polyhedrons:

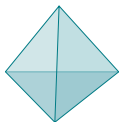

tetrahedron

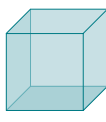

hexahedron (cube)

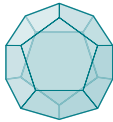

dodecahedron

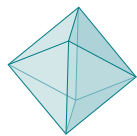

octahedron



icosahedron

See congruent, dodecahedron, face, hexahedron, icosahedron, octahedron, polyhedron, tetrahedron

regular shape

See regular polygon

relation

Connection, correspondence or contrast between a pair of objects, measures, numbers, etc. Also called relationship.

Examples

- (i) Family relationship:
Judi is the sister of Lea.



- (ii) Size relation:
Jan is taller than Helen.



- (iii) Mathematical relation.

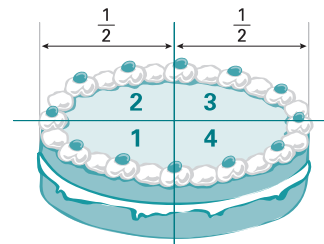

2 is half of 4

- (iv) Relation between pairs of numbers.
Often presented in a table.

x	1	2	3	4	5
y	6	7	8	9	10

$$y = x + 5$$

See arrow diagram, correspondence

remainder

The amount left over after division.

Example

$$\begin{array}{r} 25 \\ 5 \overline{) 128} \\ \underline{25} \\ 28 \\ \underline{25} \\ 3 \end{array}$$

There are different ways of expressing the remainder in the answer. They depend on the question.

↑ remainder

- (i) Question: Five boys share 128 marbles. How many marbles each?

Answer: Each boy gets 25 marbles. 3 marbles are left over.

- (ii) Question: Share \$128 among five girls.

Answer: Each girl gets \$25 and $\frac{3}{5}$ of a dollar; that is, \$25 and 60c.

See division

repeating decimal

See recurring decimal

reverse

The other way round, or opposite way round.

Example

The reverse of 385 is 583.

reverse operation

Multiplication is the reverse of division.

Addition is the reverse of subtraction.

See inverse operations, operation

revolution

One complete turn. There are 360° in one revolution.

There are four right angles in one revolution.

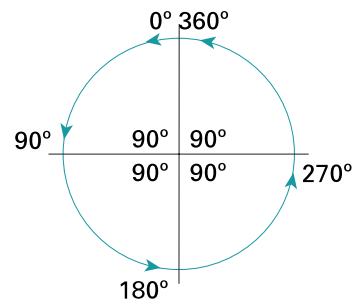

See angle, right angle

rhombus

A shape (parallelogram) with four equal sides. Opposite angles are equal.

Examples

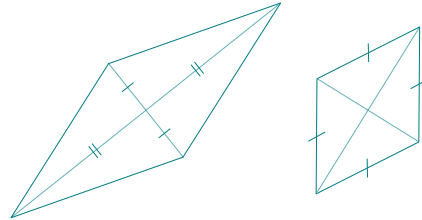

See diamond, parallelogram



right angle

(Symbol: \perp)

An angle measuring exactly 90° .

Examples

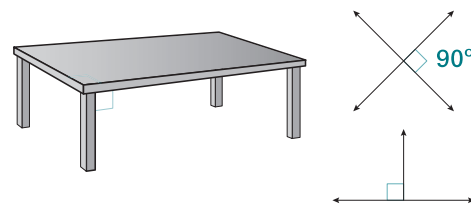

See angle

right-angled triangle

A triangle with a right angle.

Examples

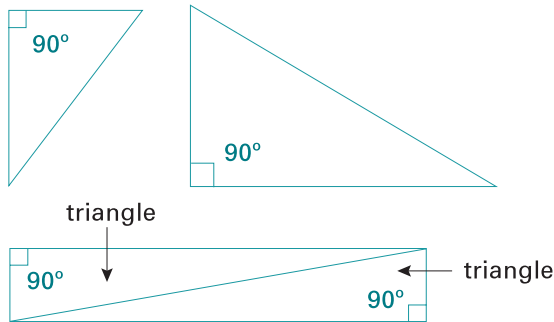

See hypotenuse, Pythagoras' theorem, right angle, tangent ratio

right 3D shape

A solid with ends or base perpendicular to height.

Examples

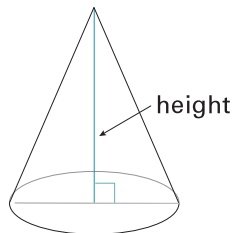

right cone

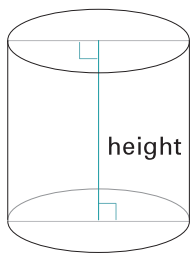

right cylinder

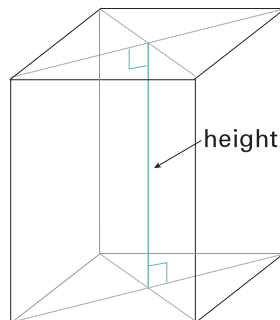

right prism

See cone, cylinder, prism

rigid

Not flexible. Stiff. A jointed structure is rigid when its angles cannot be changed (the struts will not move out of place).

A triangle forms a rigid structure.

Examples

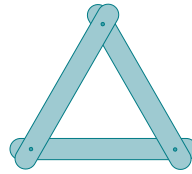

rigid shape

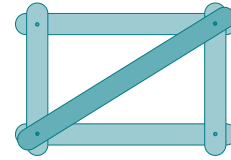

rigid shape

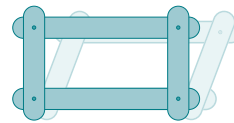

non-rigid shape (flexible)

See flexible

rise

See gradient

Roman numerals

An ancient system of numeration, where the numbers are represented by letters of the Roman alphabet.

The numerals are made up of a combination of these symbols.

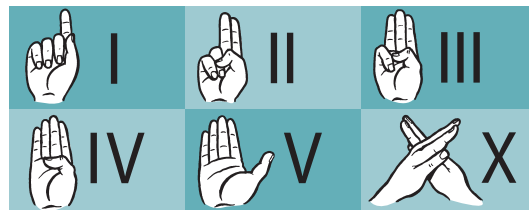

- | | |
|--------|----------------|
| I (1) | C (100) centum |
| V (5) | D (500) |
| X (10) | M (1000) mille |
| L (50) | |

Examples

2000 – MM

2002 – MMII

See numeration, see section Roman numerals on page 148

rotate

Move around an axis or centre. Revolve. Turn round and round.

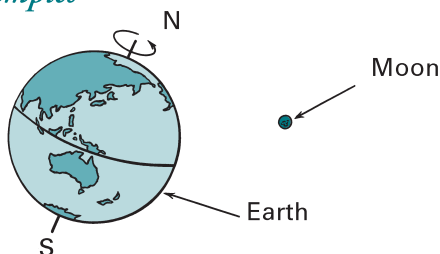
Examples

The Earth rotates around its axis.
The Moon revolves around the Earth.

rotation

The process by which an object changes position by turning about a fixed point through a given angle.

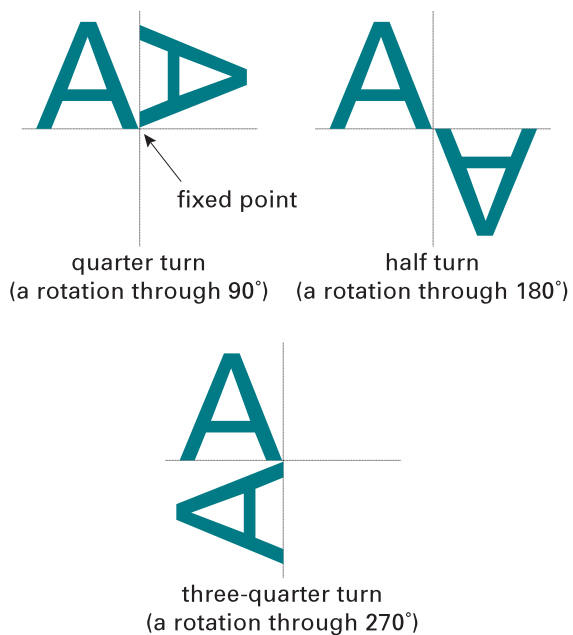
Examples**rotational symmetry**

When a shape is turned through an angle less than 360° and remains the same, it has rotational symmetry.

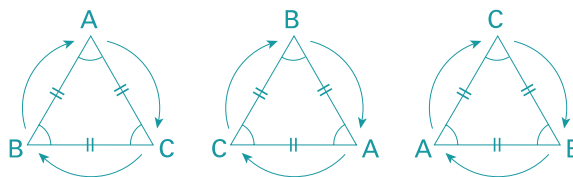
Example

An equilateral triangle has rotational symmetry.

rounding

Writing an answer to a given degree of accuracy.

Example

2764 rounded to the nearest ten becomes 2760
 rounded to the nearest hundred becomes 2800
 rounded to the nearest thousand becomes 3000

- (i) Numbers ending in 1, 2, 3 and 4 round down to the lower number.

Examples

54 rounded to the nearest ten becomes 50.
 348 rounded to the nearest hundred becomes 300.

- (ii) Numbers ending in 5, 6, 7, 8 and 9 round up to the higher number.

Examples

55 rounded to the nearest 10 becomes 60.
 356 rounded to the nearest 100 becomes 400.

See accurate, estimate, significant figure



route

A path. A way taken from start to finish, which may be traversed.

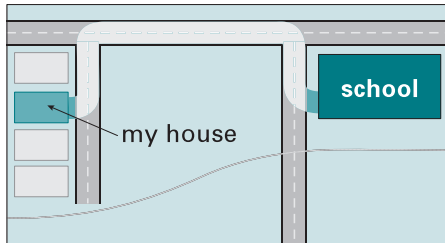
Example

My route to school

row

(i) A horizontal arrangement.

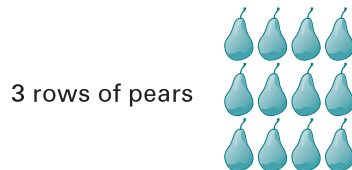
Example

(ii) Things arranged so that they make a line going from left to right.

Example

A row of numbers: 4, 5, 6, 7, 8, 9, ...

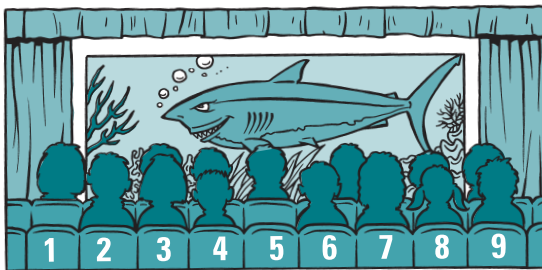

A row of seats in the theatre

See column, horizontal line

rule

(i) An instruction to do something in a particular way.

Example

Find the rule for this sequence.

$$\begin{array}{ccccccc} 1, & 4, & 7, & 10, & 13 \\ \underbrace{\quad} & \underbrace{\quad} & \underbrace{\quad} & \underbrace{\quad} & \\ +3 & +3 & +3 & +3 & \end{array}$$

The rule is 'add 3'.

(ii) Numbers in a relation are following a rule.

Example

t	1	2	3	4	5	6
D	15	30	45	60	75	90

The rule is $D = 15t$

(iii) To draw a line using a ruler.

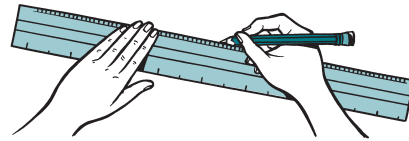
Example

See cycle game, number machine, progression, sequence

ruler

An instrument for drawing straight lines, usually made of plastic or wood. It has a scale for measuring length.

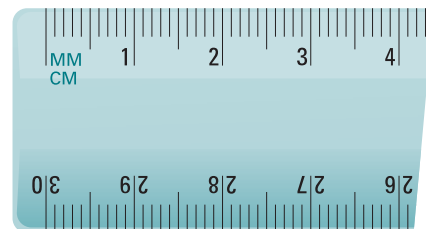

See graduated, scale

run

See gradient



s

Symbol for second.

same

Identical, alike, unchanged, not different.

Example

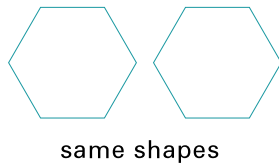

See congruent

sample

A selection of a few items taken from a larger set.

Example



In a biscuit factory they take a sample of each batch of biscuits.

satisfy

In mathematics it means 'make the equation true'.

Example

If $x < 5$, which of the numbers 8, 3, 35 or 4 satisfy the inequation?

Answer: 3 and 4, because $3 < 5$ and $4 < 5$.

scale

- (i) A thermometer, a ruler and a balance each have a scale marked on them to measure temperature, length and mass, respectively.

Examples

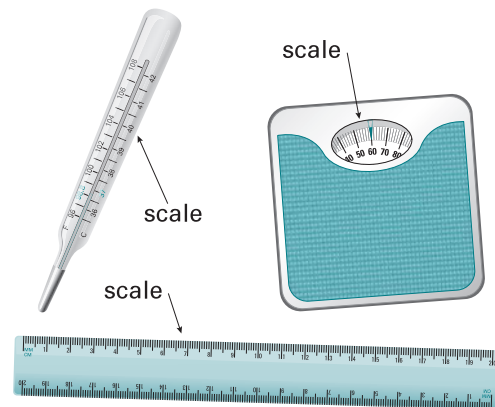

- (ii) A number line used on a graph.

Example

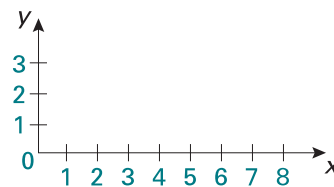

- (iii) The scale on a map or a plan shows the ratio for making things larger or smaller.

Example

SCALE OF KILOMETRES

1 cm = 10 km

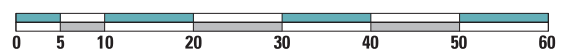

1: 1 000 000

See balance, enlargement, graph, number line, reduce, ruler, thermometer



scale drawing

A drawing or plan on which the real object is made bigger or smaller while keeping the same proportions.

Example

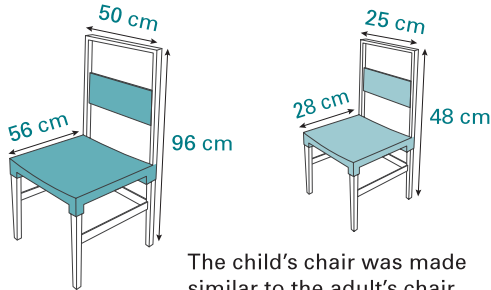

The child's chair was made similar to the adult's chair on a scale of 1 to 2 or 1 : 2.

See proportion

scalene triangle

A triangle with each side different in length.

Example

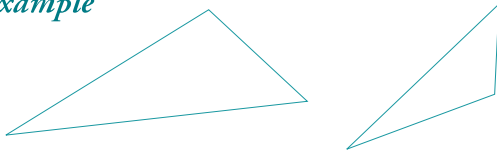

See triangle

scales

Instruments used for finding or comparing weights or masses.

Examples



spring balance for measuring weight

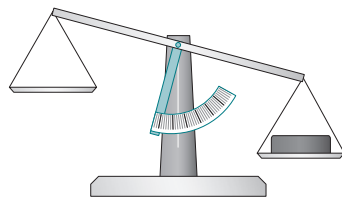

a balance for measuring and comparing masses



a balance for comparing masses



bathroom scales

See mass, weight

scientific notation

A shorthand way of writing very large or very small numbers using powers of ten.

Examples

(i) $6\,300\,000 = 6.3 \times 1\,000\,000$
 $ = 6.3 \times 10^6$
 6 places

(ii) $0.000\,567 = 5.67 \times 0.000\,1$
 $ = 5.67 \times 10^{-4}$
 4 places

See expanded notation, index notation

score

The amount of points or marks gained in a competition or test.

Example

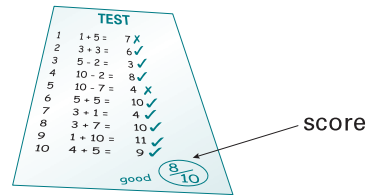

See average, mean, median, mode

second

(i) second (2nd): The ordinal number which comes after first (1st) and before third (3rd).

Example

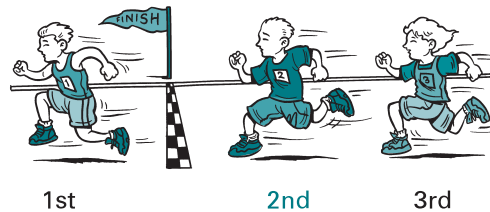

See ordinal number

(ii) second (symbol: s): A measurement of time. There are sixty seconds in one minute.

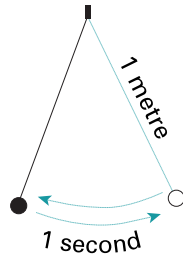
Example

One second is the time taken by a pendulum about one metre long to make one complete swing, over and back.

See pendulum

- (iii) second in angle measurement (symbol: "). A second is $\frac{1}{60}$ of a minute, which is $\frac{1}{60}$ of a degree.

See degree

section

- (i) A flat surface obtained by cutting through a solid in any direction.

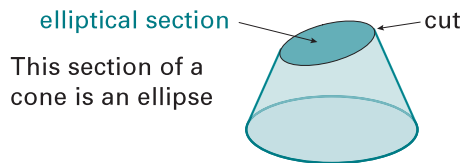
Example

This section of a cone is an ellipse

- (ii) When the cut is parallel to the base of the solid, it is called a cross-section.

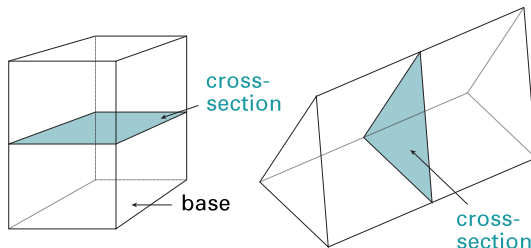
Example

See cone, cross-section of a solid, ellipse, flat, frustum, segment, solid, surface

sector graph

See pie graph

segment

A part, a section of something.

Examples

- (i) A line segment

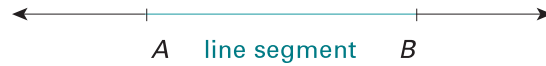

- (ii) A segment of a circle is the part of the circle between an arc and its chord.

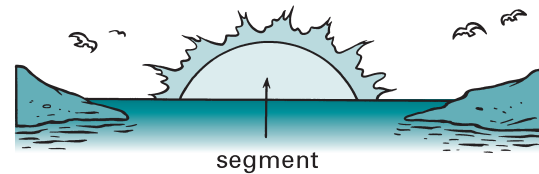
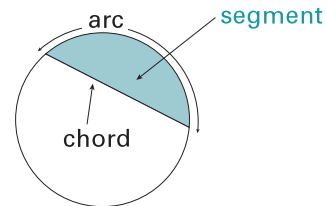

See arc, chord

selling price

Price at which something is sold.

Example

A car dealer sells a car for \$12 000. The selling price of the car is \$12 000.

See cost price, loss, profit

semicircle

Half a circle.

When you cut a circle along its diameter, you get two semicircles.

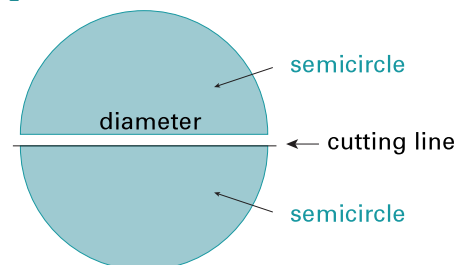
Example

See circle, diameter



sentence

A statement. In mathematics a sentence may contain pronumerals, numerals and other symbols.

See false sentence, number sentence, numeral, open number sentence, pronumeral, symbol, true sentence

sequence

A pattern, following an order or rule.

Examples

(i) 1, 3, 5, 7, ...

The rule of this sequence is 'add 2'.

(ii)



In this sequence each shape is following a pattern of rotation anticlockwise by the same amount of turn.

See anticlockwise, order, pattern, progression, rotation, rule

seriate

To put in order.

Example

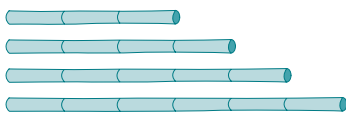

These sticks are seriated according to length.

set

(Symbol: { })

A group of objects or numbers. Each object in a set is called a member or an element of the set. The elements of a set are written inside braces { }.

Example

Set of whole numbers = {0, 1, 2, 3, 4 ...}

See braces, cardinal number, element of a set, subset, whole numbers

set square

An instrument used for geometrical drawings, made of wood, plastic or metal.

Examples

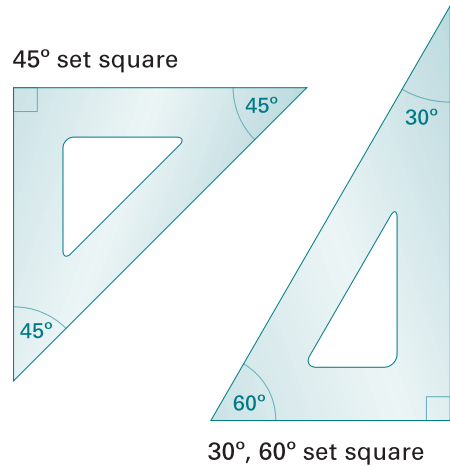

Set squares are used for drawing parallel lines, right and other angles, etc.

See parallel lines, right angle

shadow stick measuring

A useful, old method for calculating heights that cannot be directly measured. It is based on the properties of similar triangles.

Example

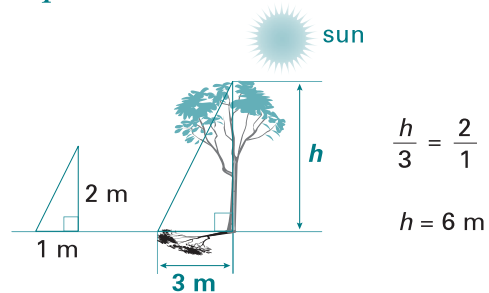

We measure the shadow of a stick of a known length and the shadow cast by the tall object. The length of the stick and the object, and their shadows, are in the same ratio.

See ratio, similar

shape

The form of an object.

Examples

2D shapes: triangles, quadrilaterals

3D shapes: cubes, prisms, pyramids

See cube, dimension, prism, pyramid, quadrilateral, three-dimensional, triangle, two-dimensional

sharing

See division

SI

The international metric system.

The symbol SI comes from the initials of the French term *Système Internationale d'Unités* (international unit system).

This system is based on the metre, gram, second, ampere, kelvin, candela and mole.

See metric system

side

A line segment which is a part of a perimeter or of a figure.

Examples

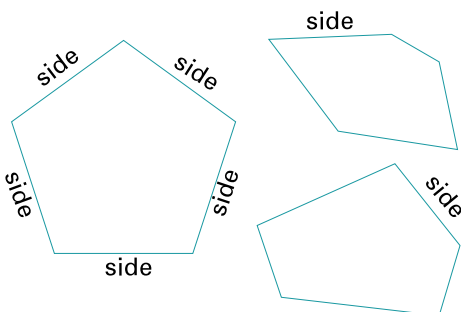

A pentagon has five sides.

See line segment, pentagon, perimeter, regular polygon

side view

A diagram, as seen from the side.

Example

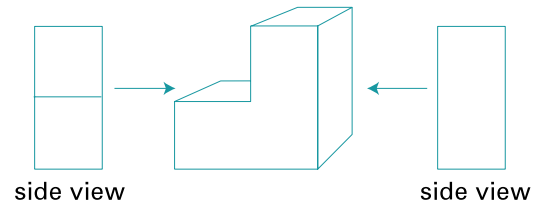

See cross-section of a solid, front view, plan

sign

A symbol used to show an operation or a statement.

Examples

Addition sign +

Subtraction sign −

Multiplication sign ×

Division signs ÷, $\frac{\quad}{\quad}$, $\overline{\quad}$

Equal sign =

See operation, symbol, see section List of symbols on page 147

significant figure

A digit in a number that is considered important when rounding off or making an approximation.

Examples

3745 rounded to two significant figures is 3700.

0.165 of a metre rounded to one significant figure is 0.2 of a metre.

See approximately, rounding



similar

The same in shape but not in size.

Two shapes are similar if the corresponding angles are equal and all sides are enlarged or reduced in the same ratio.

Examples

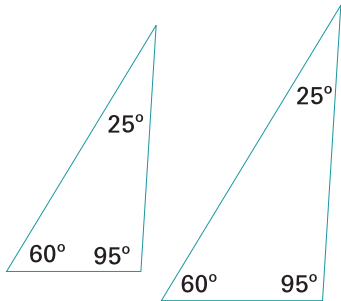

similar triangles

See congruent, enlargement, ratio, reduce

simple fraction

A fraction such as $\frac{3}{4}$, $\frac{1}{2}$, $\frac{7}{10}$.

Also called a common, proper or vulgar fraction.

Example

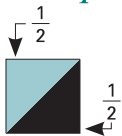

One whole has been divided into two equal parts (halves)

- 1 ← number of parts taken from the whole (numerator)
- 2 ← number of parts the whole has been divided into (denominator)

See denominator, fraction, numerator

simple interest

Interest payable on the principal alone is called simple interest. The interest is charged each year for the period of the loan.

Example

John borrows \$1000 from his bank to buy a guitar at a simple interest rate of 6 per cent over a period of 5 years.

John has to pay $\frac{6}{100} \times \$1000 = \60 each year.

John has to pay a total amount of interest of $\$60 \times 5 = \300 on the loan.

See interest, interest rate, principal

simplify

Make simple. Write in the shortest, simplest form.

Examples

Simplify $\frac{8}{10} + \frac{4}{20}$ $= \frac{4}{5} + \frac{1}{5}$ $= \frac{5}{5}$ $= 1$	Simplify $\frac{a^2b}{ab}$ $= \frac{a \times a^1 \times b^1}{a^1 \times b^1}$ $= a$
---	---

See cancelling

simultaneous equations

Equations that have the same unknown quantities and are solved together.

Example

$$\begin{aligned} a + b &= 10 \\ 2a &= 6 \quad \Rightarrow \quad a = 3 \checkmark \end{aligned}$$

$$\begin{aligned} 3 + b &= 10 & \text{Check:} \\ b &= 10 - 3 & a + b = 10 \\ b &= 7 \checkmark & 3 + 7 = 10 \checkmark \end{aligned}$$

The solution is $a = 3$ and $b = 7$.

size

The amount, magnitude or dimension.

Examples

- (i) The size of this angle is 37° .

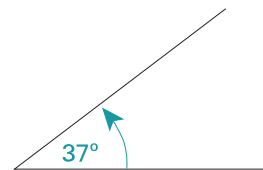

- (ii) Helen wears size ten clothes and size two shoes.

skew lines

Lines that do not lie in the same plane; they cannot intersect and are not parallel.

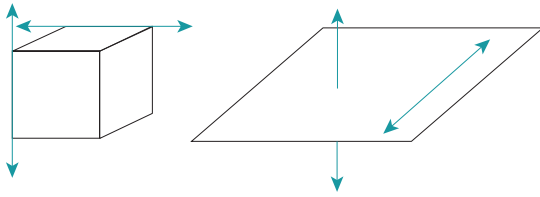
Examples

See intersect, parallel lines

slide

Change position on the surface.

See flip, rotation, translation, turn

slope

The slope of a line measures the steepness of the line. Slope is calculated by $\frac{\text{rise}}{\text{run}}$ (rise over run).

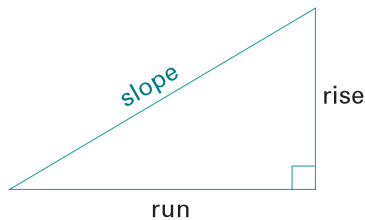
Example

See gradient, tangent ratio

solid

A solid is a figure with three dimensions, usually length, width and height (depth).

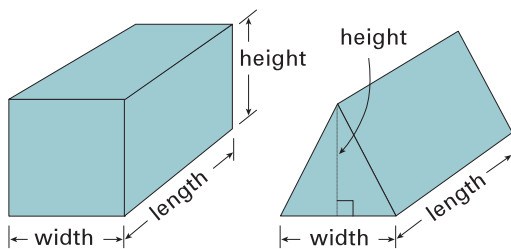
Examples

See height, length, three-dimensional, width

solution

The answer to a problem or question.

Example

The equation $x + 4 = 9$

has a solution $x = 5$.

solve

Find the answer.

See calculate, solution

some

Not all of the whole. At least one.

Examples

(i)



a whole cake

some of the cake

(ii) Some of the children are walking away.

**sorting**

Putting objects into groups according to attributes.

Example

	green	not green
thick		
not thick (thin)		

Attributes are colour and thickness.

See attribute, Carroll diagram, classification, classify, group



space

Space is a three-dimensional region.
Spatial figures (solids) have three dimensions.
See dimension, region, solid, three-dimensional

span

Stretch from side to side, across.
See handspan

spatial

Things which are relating to, or happening in, space.

speed

The rate of time at which something travels.
The distance travelled in a unit of time.

Example



A car travelled sixty kilometres in one hour.
Its speed was 60 km/h.

See distance, knot, unit of measurement

sphere

A three-dimensional shape like a round ball.
A sphere has one curved surface and no corners or edges. Every point on the sphere's surface is the same distance from the sphere's centre.

Examples



a basketball



the Earth

See three-dimensional

spinner

A disc marked with numbers used in chance games.

Examples

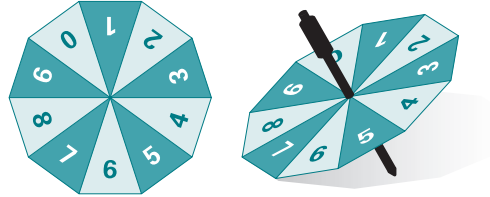

spiral

A curve like a coil on a flat surface.

Example

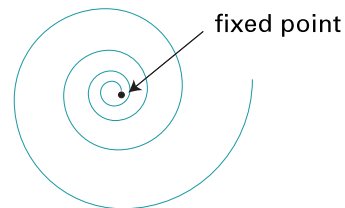

A spiral is a continuous curve moving around a fixed point so that its distance from the fixed point is always increasing.

See curve, distance

spring balance

An instrument that measures weight.

A spring inside it is extended by the force equal to the mass of the object.



See mass, weight

square

A quadrilateral with four equal sides and four right angles.

Example

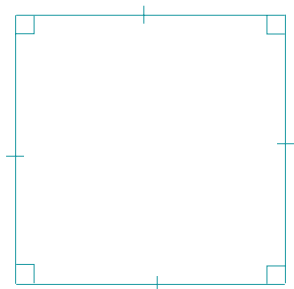

See quadrilateral, right angle

square centimetre

(Symbol: cm^2)

A square centimetre is a unit for measuring area.

Examples

The area is one square centimetre.



The area of this shape is three square centimetres.

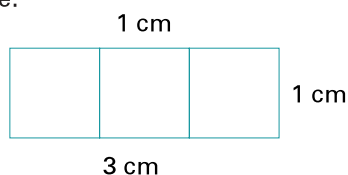

$$3 \text{ cm} \times 1 \text{ cm} = 3 \text{ cm}^2$$

See area, unit of measurement

square kilometre

(Symbol: km^2)

A unit for measuring very large areas.

$$1 \text{ km}^2 = 1\,000\,000 \text{ m}^2$$

Examples

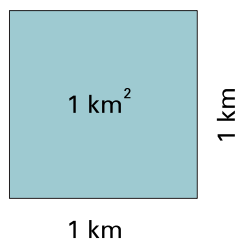

The area of the Northern Territory is $1\,346\,200 \text{ km}^2$.



Smaller areas, like the sizes of towns or suburbs, are measured in hectares.

$$1 \text{ km}^2 = 100 \text{ ha}$$

See area, hectare, unit of measurement

square metre

(Symbol: m^2)

A unit for measuring area.

$$1 \text{ m}^2 = 10\,000 \text{ cm}^2$$

Examples

- (i) This man is holding a piece of cardboard which has an area of one square metre.

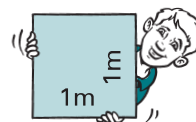

- (ii) This rug has an area of 4.5 m^2 .

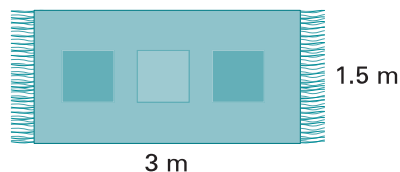

See area, square centimetre, unit of measurement

square number

A number that can be represented by dots in the shape of a square.

Examples



4



9



16

See index, index notation, triangle number



square of a number

The answer you get when you multiply a number by itself.

Examples

$$2^2 = 2 \times 2 = 4$$

$$3^2 = 3 \times 3 = 9$$

$$(0.5)^2 = 0.5 \times 0.5 = 0.25$$

See index, index laws, square root

square paper

Paper ruled in squares, used for scale drawing and graphing.

Examples

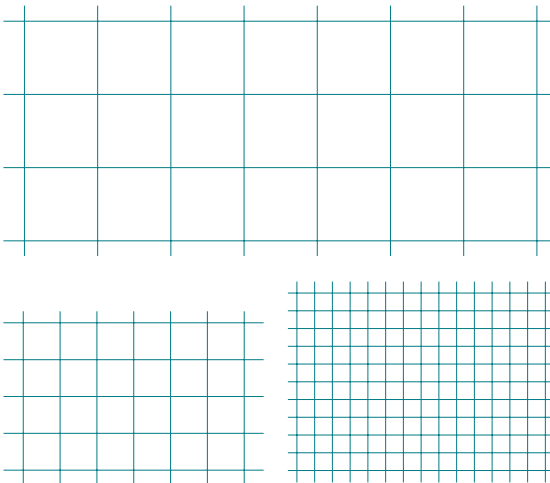

See dot paper, graph, isometric paper, scale drawing

square root

A number which, when multiplied by itself, produces the given number.

The inverse operation of squaring a number.

Examples

$$\sqrt{2} \times \sqrt{2} = 2$$

$$\sqrt{9} \times \sqrt{9} = 9$$

$$+2^2 = 2 \times 2 = +4$$

$$(-2)^2 = -2 \times -2 = +4 \} \therefore \sqrt{4} = \pm 2$$

See square of a number

standard unit

Units of measure that are internationally accepted by agreement are said to be 'standard measures'; for example, the metric measures.

See SI, unit, unit of measurement

statistics

The study concerned with the collection and classification of numerical facts. The information collected is called data. Data can be represented in a table or on a graph, and interpreted and analysed.

Example

FAVOURITE FOODS

Meat	Vegetables	Fruit	Sweets
Paul S.	Carlo	Anne	Dean
John	Hirani	James	Belinda
Tibor		Paul B.	Quong
Jackie		Claire	Brad
Toula		Ranjit	Ali
Sarah			Anna
David			Jhiro
Jeremy			Peter
			Samantha
			Halima

The information in the table is the data. There are 25 children in the class.

8 children prefer meat

$$\therefore \frac{8}{25} \times \frac{100}{1} = 32\% \text{ of the class prefer meat}$$

2 children prefer vegetables

$$\therefore \frac{2}{25} \times \frac{100}{1} = 8\% \text{ of the class prefer vegetables}$$

5 children prefer fruit

$$\therefore \frac{5}{25} \times \frac{100}{1} = 20\% \text{ of the class prefer fruit}$$

10 children prefer sweets

$$\therefore \frac{10}{25} \times \frac{100}{1} = 40\% \text{ of the class prefer sweets}$$

The percentages are statistics about the food preferences of the class.

See data, per cent

straight angle

An angle of 180°.

Example

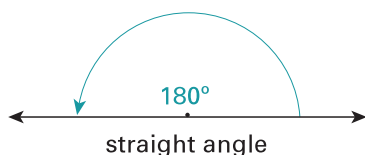

See angle

straight edge

An object that can be used to draw straight lines.

Example

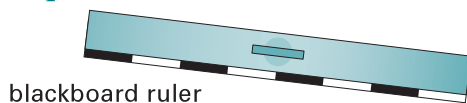

blackboard ruler

straight line

See line, line segment

subset

A set within a set.

Examples

- (i) If each element of a set S (below) is also an element of a set T, then S is called a subset of T.

Set T = {natural numbers to twenty-five}

Set S = {square numbers to twenty-five}

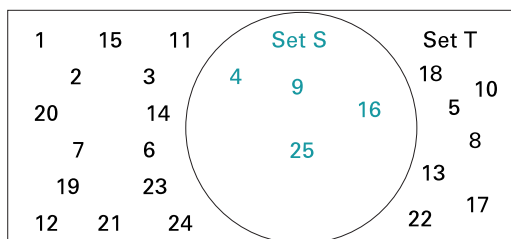

- (ii) Set A = {all children in your class}
Set B = {all girls in your class}
Set B is a subset of set A, because all the elements in set B are also in set A.

See combination, set

substitution

- (i) Something standing in place of another.
- (ii) The replacement of a variable (a letter in a code message or a place holder in a number sentence) by a number.

Examples

- (i) If $a = 5$ and $b = 2$, what is value of $2a + 2b$?

$$\begin{aligned} 2a + 2b &= 2 \times 5 + 2 \times 2 \\ &= 10 + 4 \\ &= 14 \end{aligned}$$

- (ii) In this secret code, numbers are substituted for letters.

A	B	C	D	E	F	G	...	2	1	4	7	5
1	2	3	4	5	6	7	...	B	A	D	G	E

See code, number sentence, place holder, variable

subtract

Take away.

Find the difference. Find the complement.

See difference, subtraction

subtraction

- (i) Taking away (finding what is left).

Example

Jessica had five pencils and gave three to Mario. How many pencils did Jessica keep?

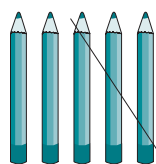

$$5 - 3 = \square$$

$$5 - 3 = 2$$

Jessica kept 2 pencils.



▼ subtraction continued...



(ii) Difference (comparison).

Example

Remy has seven pencils and Robin has three pencils. How many more pencils has Remy than Robin?

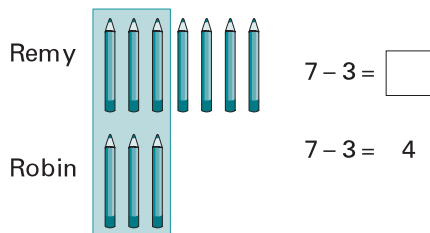

Remy has 4 more pencils than Robin.

(iii) Complementary addition (missing addend, counting on).

Example

Rowan has three pencils, but needs seven. How many more must he get?



Rowan must get 4 more pencils.

Subtraction may be represented on a number line.

Example

Show on the number line:

$5 - 3 = 2$

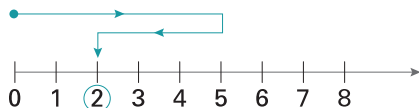

See complementary addition, difference, number line

subtrahend

A number which is to be subtracted from another number.

Example

$$\begin{array}{ccccccc} 12 & - & 4 & = & 8 \\ \uparrow & & \uparrow & & \uparrow \\ \text{minuend} & & \text{subtrahend} & & \text{difference} \end{array}$$

Four is the subtrahend.

See difference, minuend, subtract

sum

The answer to an addition problem. It is the total amount resulting from the addition of two or more numbers (called addends), quantities or magnitudes.

Example

$$\begin{array}{ccccccc} 3 & + & 4 & = & 7 \\ \uparrow & & \uparrow & & \uparrow \\ \text{addends} & & & & \text{sum} \end{array}$$

Seven is the sum.

See addend, addition

supplementary angles

Two angles which together make 180°.

Example

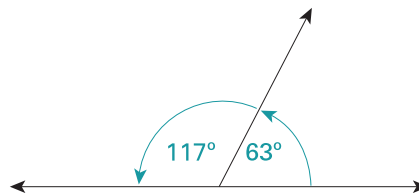

Angles 117° and 63° are supplementary.

Angle 117° is called the supplement of 63°.

Angle 63° is called the supplement of 117°.

See complementary angles, parallel lines

surface

(i) The outside of something.

Example

The surface of the tennis ball is furry.

(ii) The top level of a liquid.

Example

Leaves float on the surface of a lake.

The surface of an object may be flat or curved.

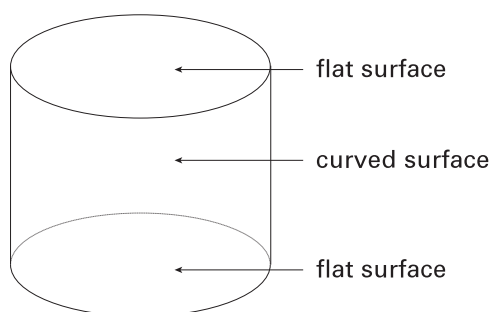
Example

A cylinder has two flat surfaces and one curved.

See area, cylinder

surface area

The total area of the outside of a 3D shape.

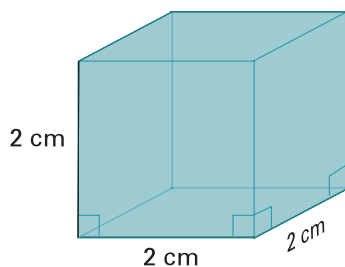
Example

A cube with two centimetre sides has a surface area of

$$6 \times (2 \times 2) \text{ cm}^2 = 24 \text{ cm}^2$$

See area, cube, surface

symbol

A letter, numeral or mark which represents something. We do not write a full stop after a symbol.

Examples

1	2	3	+	-	×	÷
=	≠	>	<	≈	%	□
cm	kg	ha	m ³	∠		
a	b	x ²	2x			

See abbreviation, place holder, pronomeral, see section Useful information pages 146–7

symmetry

A shape has symmetry or is symmetrical when one half of the shape can fit exactly over the other half.

Shapes are called symmetrical if they have one or more lines (axes) of symmetry.

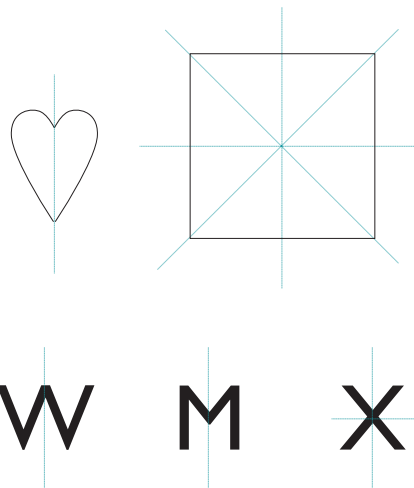
Examples

See asymmetry, axis, line of symmetry, rotational symmetry

Système Internationale d'Unités

See SI

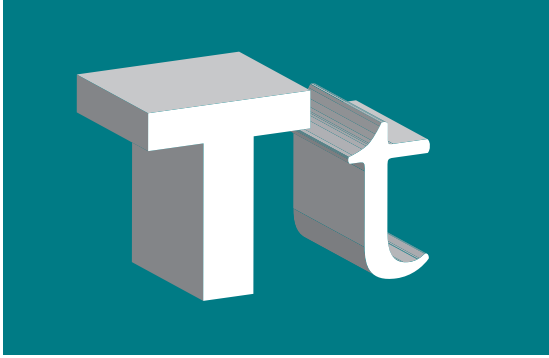

**t**

Symbol for tonne.

table

- (i) An arrangement of letters or numbers in rows or columns.

Example

×	1	2	3	4	5	6
1	1	2	3	4	5	6
2	2	4	6	8	10	12
3	3	6	9	12	15	18
4	4	8	12	16	20	24
5	5	10	15	20	25	30
6	6	12	18	24	30	36

- (ii) When multiplication facts are arranged in order, they are then called multiplication tables.

Example

The tables of nine

$$1 \times 9 = 9 \qquad 6 \times 9 = 54$$

$$2 \times 9 = 18 \qquad 7 \times 9 = 63$$

$$3 \times 9 = 27 \qquad 8 \times 9 = 72$$

$$4 \times 9 = 36 \qquad 9 \times 9 = 81$$

$$5 \times 9 = 45 \qquad 10 \times 9 = 90$$

See multiplication

take away

Remove, subtract. It is one method of subtraction.

Example

I had fifteen marbles and I lost seven.

How many do I have now?

$$15 - 7 = 8 \text{ (take away seven from fifteen)}$$

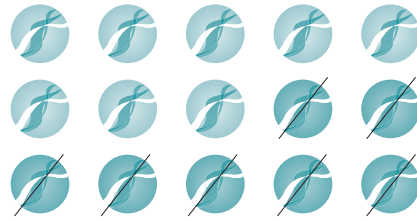

Answer: I have eight marbles now.

See subtraction

tally

A record of items made by placing a mark to represent each item. The marks are usually drawn in groups of five, with the fifth mark in each group crossing the other four, to make them easy to count.

Example

A tally of 13 items

|||| |

tangent ratio

(Symbol: tan)

In right-angled triangles the terms opposite and adjacent always refer to the two shorter sides. The longest side is called the hypotenuse.

The side opposite angle A is called 'opposite side'. The side adjacent to angle A is called 'adjacent side'. The side opposite the right angle is called 'hypotenuse'.

The ratio $\frac{\text{opposite side}}{\text{adjacent side}} = \tan A$

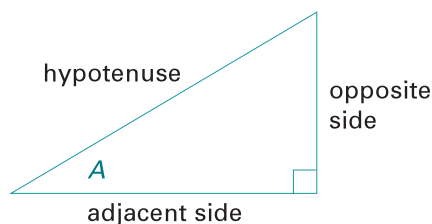
Example

See gradient, right-angled triangle, Pythagoras' theorem

tangram

A Chinese puzzle made up of a square cut into seven pieces that can be rearranged to make many varied shapes.

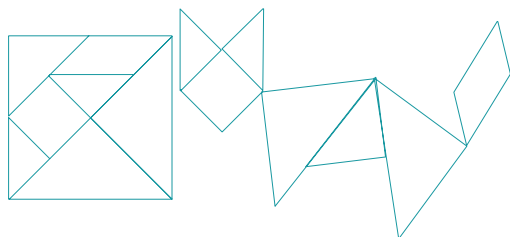
Example**tape measure**

A strip of tape or thin metal marked with centimetres.

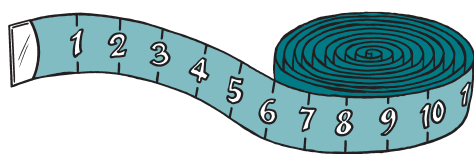
**tare**

Mass of packaging in which goods are packed.

See gross mass

temperature

How hot or how cold something is.

Temperature is measured in degrees Celsius ($^{\circ}\text{C}$).

Examples

- (i) Water freezes (changes to ice) at 0°C .



- (ii) Water boils at 100°C .

- (iii) Normal body temperature is about 37°C .

See degree Celsius, thermometer

template

An instrument for drawing shapes. It may be one of two types:

- (i) Cardboard or plastic pieces around which we draw.

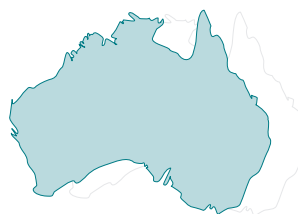
Example

- (ii) A sheet of cardboard or firm plastic out of which shapes have been cut.

Example

template

**term**

- (i) Each of two quantities in a ratio or a fraction.

Example

$$\frac{3}{4} \quad 1:7$$

▼ **term continued...**



- (ii) Each of the quantities connected by + or – in an algebraic expression or equation.

Example

$$3a - 3b \quad y = x + 1$$

terminate

To come to an end, finish, not to go any further.

terminating decimal

A decimal fraction that is not recurring, that has ‘an end’.

Example

$$\frac{1}{4} = 0.25$$

$$\begin{array}{r} 0.25 \\ 4 \overline{)1.00} \\ \underline{-8} \\ 20 \\ \underline{-20} \\ 0 \end{array} = (\text{end})$$

See recurring decimal

tessellation

A complete covering of a plane by one or more figures in a repeating pattern, with no overlapping of, or gaps between, the figures. Mosaic and pavement shapes tessellate.

Examples

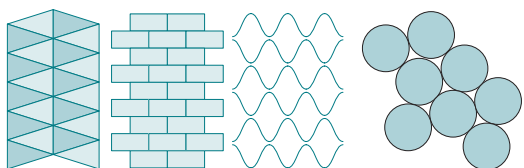

These shapes tessellate.

Circles do not tessellate.

Certain shapes will cover a surface completely: squares, equilateral triangles, hexagons, etc. These are said to ‘tessellate’.

See circle, pattern, plane, square, triangle

tetragon

A plane shape with four sides and four angles.

See quadrilateral

tetrahedron

A solid (polyhedron) with four faces. Also called a triangular pyramid.

A regular tetrahedron is made of four congruent equilateral triangles and belongs to the group called platonic solids.

Examples

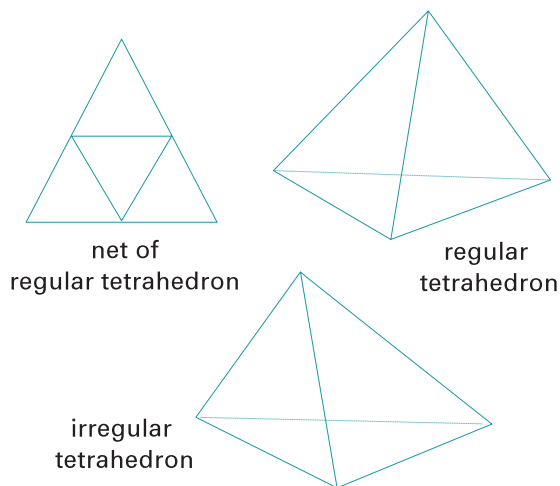

net of regular tetrahedron

regular tetrahedron

irregular tetrahedron

See polyhedron, regular polyhedron

thermometer

An instrument for measuring temperature.

Example

This thermometer shows a temperature of 100 °C.

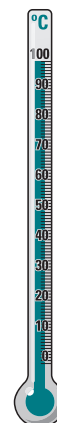

See degree Celsius, temperature

third

- (i) The ordinal number which comes after second and before fourth.

Example



1st 2nd 3rd 4th

- (ii) One third means one of three equal parts. Written as $\frac{1}{3}$.

Example

$\frac{1}{3}$ has been coloured in

$\frac{1}{3}$	$\frac{1}{3}$	$\frac{1}{3}$
---------------	---------------	---------------

See ordinal number

thousand

Ten hundreds, written as 1000.

See hundred

thousand separator

For easy reading, large numbers are divided into groups of three digits either side of the decimal point.

Example

26 375 159.123 45

The correct separator is a narrow space between the groups of digits, as shown, not the comma that was used in the past.

three-dimensional

(3D)

When something has length, width and height, that is, three dimensions, then it is three-dimensional. Space figures (solids) are three-dimensional.

Example

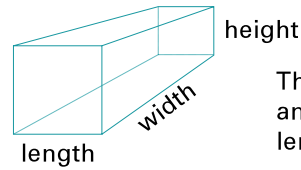

The sketch produces an illusion of depth, length and height.

See dimension, solid, sphere

time interval

The time that passes between two events.

Some units of time are:

second s

minute min

hour h

day d

week, month, year, decade,
century, millenium

See unit of measurement

time line

A line on which intervals of time are recorded in chronological order.

Example



See time interval



times

(Symbol: \times)

A word used for multiplication.

Examples

When we multiply 3×5 , we say 'three times five'.

Also, in $5(a + b)$, we say 'five times $(a + b)$ '.

tonne

(Symbol: t)

A tonne is a metric unit for measuring mass.

$$1 \text{ t} = 1000 \text{ kg}$$

Examples

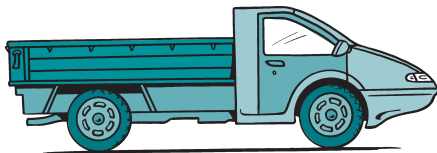

The mass of this empty utility is 1435 kilograms or 1.435 tonnes.



This water tank contains 1000 litres of water. The mass is 1000 kilograms or one tonne.

See kilogram, litre, mass, metric system

topology

The part of mathematics that deals with non-measurable properties of things; of insides and outsides, surfaces, shapes and connections.

Topology is concerned with relative positions, not measurement.

Example

Square $ABCD$ can be distorted to look like this:

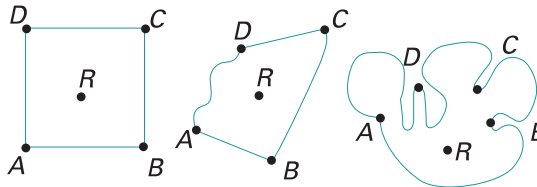

R always remains inside the figure.

Topology is sometimes called 'rubber-sheet geometry'.

See property

torus

A 3D shape, like a doughnut or a tyre tube.

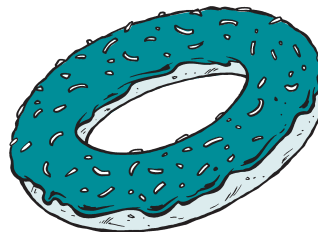

total

- (i) Sum. When you add things or values together, the answer is the total.

Example

$$10 + 20 + 25 = 55$$

↑
total

- (ii) Whole.

Example

The total area of the farm is 80 hectares.

See add, sum

transformation

- (i) The process by which the shape, position or size of an object is changed.

See enlargement, flip, projection, reduce, reflection, rotation, translation

- (ii) The process by which the form of an expression is changed.

Examples

$$\frac{1}{2} = 0.5 = 50\%$$

The formula for finding the area,

$A = l \times w$, can be transformed into:

$$l = \frac{A}{w}$$

- (iii) The process by which a set of numbers (or objects) is associated in one-to-one or many-to-one correspondence with another set of numbers (or objects).

See many-to-one correspondence, one-to-one correspondence

translation

When a shape is moved along a straight line without being flipped, rotated or reflected, we say it has been translated.

Example

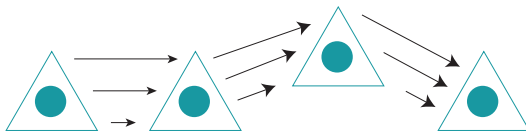

See flip, reflection, rotation, slide, turn

transversal

A straight line crossing two or more lines.

Example

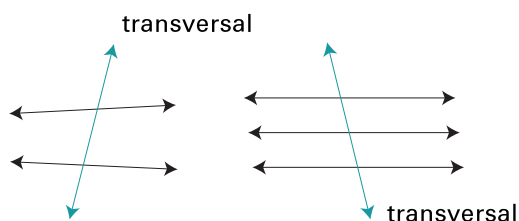

See line, parallel lines

trapezium

A four-sided figure (quadrilateral) with one pair of sides parallel and the other pair not parallel.

Example

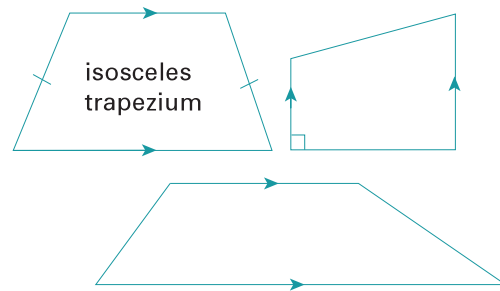

When the two sides that are not parallel are equal, then the trapezium is isosceles.

See isosceles triangle, parallel lines, quadrilateral

trapezoid

A quadrilateral with no parallel sides.

traversable

A curve or route is traversable if it can be traced without lifting the pencil or going over any part of the curve more than once.

Examples

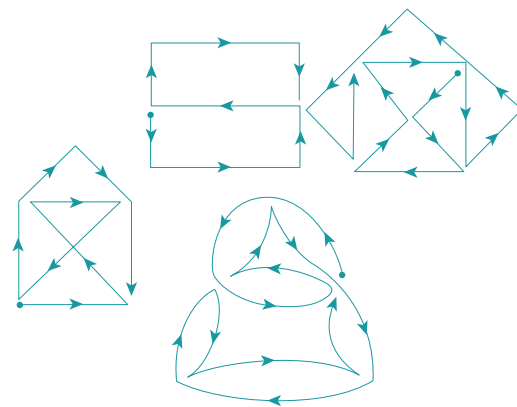

These routes are traversable.

treble

Make three times bigger or multiply by three.

See multiplication



trundle wheel

A wheel, usually one metre in circumference, used for measuring distance. The wheel often gives a click sound at each revolution (one metre), so the number of metres can be counted.

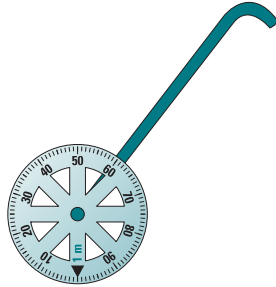

See circumference, metre

turn

Move. Change position. Rotate.

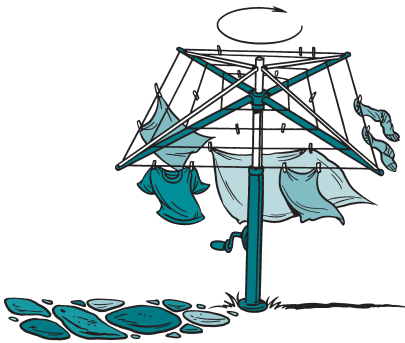

See rotation

twelve-hour time

A period of one day (twenty-four hours) divided into two halves of twelve hours each. Twelve-hour time should include a.m. and p.m.

Example

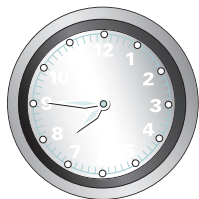

This clock shows either 7.45 a.m. or 7.45 p.m.

See a.m., p.m., twenty-four hour time

twenty-four hour time

A period of one day divided into twenty-four hourly divisions, to prevent errors between a.m. and p.m. times.

Example

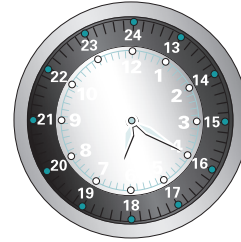

A 24-hour clock

12-hour time 24-hour time

1 a.m. 0100 one hundred hours

10 a.m. 1000 ten hundred hours

1 p.m. 1300 thirteen hundred hours

3.40 p.m. 1540 fifteen-forty hours

See a.m., p.m., twelve-hour time

twice

Two times, or double.

Example

Twice six is $2 \times 6 = 12$

two-dimensional

(2D)

When something has length and width, then it has two dimensions and is two-dimensional. Plane shapes and surfaces have two dimensions.

Examples

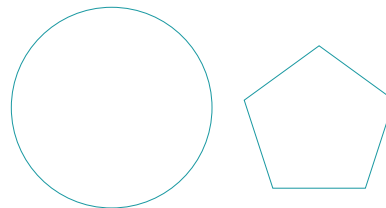

Plane regions have two dimensions.

See dimension, length, plane shape, region, surface, width



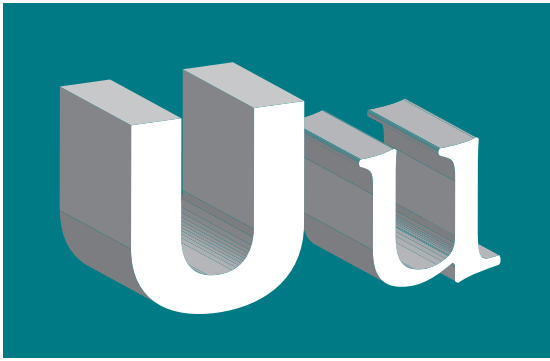

unequal

(Symbol: \neq)

Not equal.

Example

$$3 \neq 4$$

Read as: 'Three is not equal to four'.

See inequality, not equal

union

Combining two or more things.

unit

Unit is another name for one.

The unit column in our number system refers to the first column to the left of the decimal point. In 425.0, the unit digit is 5.

Example

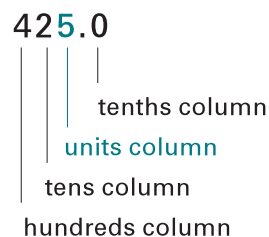

See metric system, unit of measurement

unitary method

A simple way of solving problems, by working out the value of one unit.

Example

Five kilograms of grapes cost \$14.50. How much for three kilograms?

$$5 \text{ kg} = \$ 14.50$$

$$1 \text{ kg} = \frac{\$14.50}{5} = \$ 2.90$$

$$3 \text{ kg} = \$ 2.90 \times 3 = \$8.70$$

unit, basic

Units, including those for mass, length and time, form the basis for a system of measurement.

Example

The metre, the kilogram and the second are base units of the metric system (SI).

See section Metric relationships on page 149, metric system, unit of measurement

unit of measurement

A standard unit such as a kilometre, gram, minute, litre, etc.

See standard unit

unit square

A square with sides of length equal to one unit of length or distance.

Example

A square with sides one metre long has an area of one square metre (1 m^2).

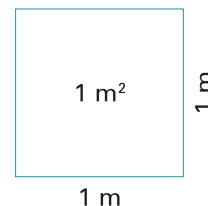

See distance, unit of measurement

unknown value

In number sentences, algebraic expressions or equations, the unknown values are represented by pronumerals or variables.

Examples

$$\begin{array}{cc} 2 \square = 10 & x - 7 \geq 5 \\ \uparrow & \uparrow \\ \text{unknown value} & \text{unknown value} \end{array}$$

$$\begin{array}{cc} 2a - 2b \\ \uparrow \quad \uparrow \\ \text{unknown values} \end{array}$$

See number sentence, pronumeral, variable

unlike terms

Terms that are not like. Unlike terms cannot be combined or simplified by adding or subtracting.

Examples

$$\begin{array}{cc} 2a + 3b & 2a + a \\ \uparrow \quad \uparrow & \uparrow \quad \uparrow \\ \text{unlike terms} & \text{like terms} \end{array}$$

See like terms





V

Symbol for volume.

value

- (i) When an expression is simplified, the result is the value of the expression.

Example

$$\begin{aligned} & \frac{3+5}{2} \times 7 \\ &= \frac{8}{2} \times 7 \\ &= 4 \times 7 \\ &= 28 \end{aligned}$$

28 is the value of $\frac{3+5}{2} \times 7$

- (ii) When solving equations, we evaluate them.

Example

Find the value of $\frac{x+5}{2}$, if $x = 10$.

Answer: $\frac{10+5}{2} = 7.5$

7.5 is the value.

- (iii) The amount of money something is worth.

Example

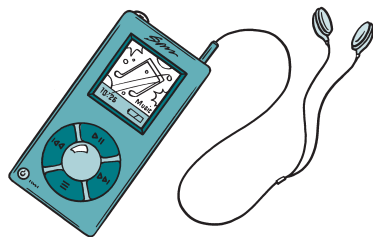

An MP3 player costs \$78. Its value is \$78.

See equation, evaluate, place value

vanishing point

In perspective, the point or points at which all parallel lines appear to meet.

Example

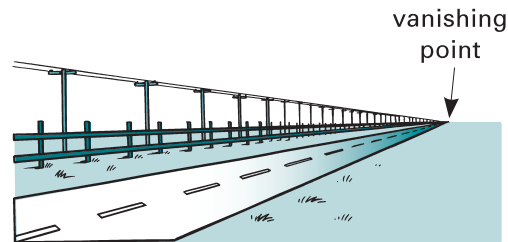

See perspective

variable

- (i) A symbol or letter representing an unknown member of a set. In algebraic expressions, a variable stands for a value. Sometimes it is called an unknown.

Example

In $x^2 + 3x + 2 = 0$, x is the variable.

- (ii) The same variable may have different values under different conditions.

Example

$$\begin{aligned} x + 3 &= 5 & x &= 2 \\ x - 1 &= 10 & x &= 11 \end{aligned}$$

- (iii) A mathematical sentence that has at least one variable is called an open number sentence.

Example

$x + 3 = 7$ is true only when $x = 4$.

The number 4 is called the solution of $x + 3 = 7$.

If x is replaced by any other number, the sentence will become not true (false).

See algebraic expression, constant, number sentence, open number sentence, place holder, pronumeral, symbol

Venn diagram

A diagram used to represent sets and relationships between sets.

Example

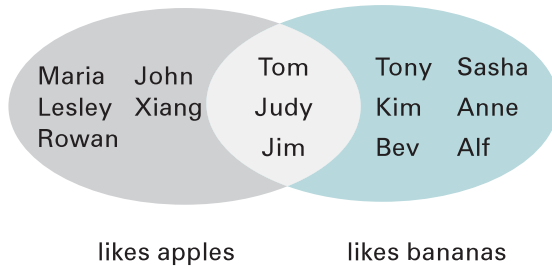

See diagram, set

vertex

(Plural: vertices)

Top, the highest part or point.

A point where two or more adjacent lines meet to form an angle or a corner.

Example

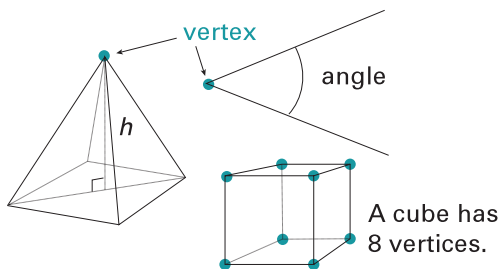

In plane or solid figures, the vertex is the point opposite the base.

See apex, arm of an angle

vertical

A vertical line is perpendicular (at right angles) to the horizon.

Examples

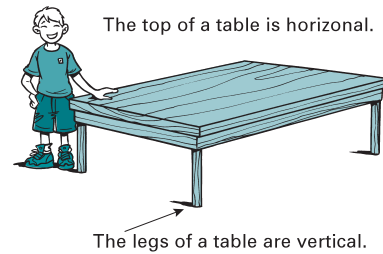
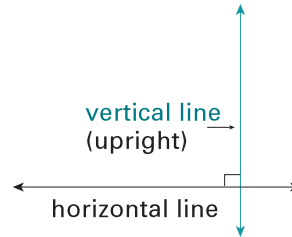

See axis, horizon, horizontal line, perpendicular, right angle

vertically opposite angles

When two lines intersect, they make four angles at the vertex. The angles opposite each other are equal in size and are called vertically opposite angles.

Example

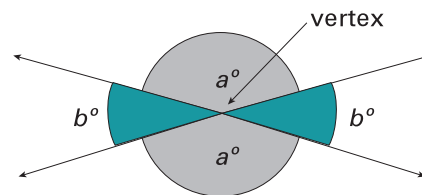

See complementary angles, parallel lines, supplementary angles, vertex



volume

The amount of space inside a container, or the actual amount of material in the container.

Example

The volume of this object is 36 cubic units.

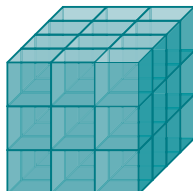

Some units of volume are:

- (i) For the volume of solids:
 - cubic centimetre** cm^3
 - cubic metre** m^3
- (ii) For the volume of liquids:
 - millilitre** mL
 - litre** L
 - kilolitre** kL
 - megalitre** ML

See capacity, cubic centimetre, cubic metre, cubic unit, section Metric relationships on page 149, solid

vulgar fraction

See simple fraction





Astronaut in space:
his mass is still 75 kg
but he is weightless.

week

A period of time: seven days. There are fifty-two weeks in a year.

See days of the week

weight

The pull of gravity on an object. The true meaning of the term 'weight' is a complicated physics problem. The weight of an object changes with the change of the gravitational pull. The mass of an object (the amount of matter the object is made of) remains constant.

Example

Astronauts become weightless in space but the mass of their bodies does not change.

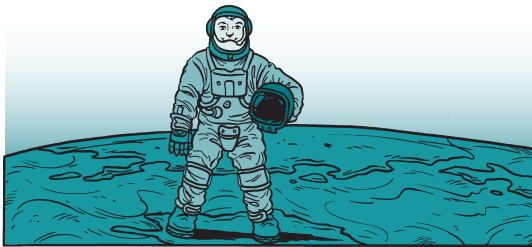

Astronaut on Earth:
his mass = 75 kg
his weight \approx 75 kg

People often speak incorrectly of weight when they really mean mass.

See mass

whole numbers

Zero together with all counting numbers.

{0, 1, 2, 3, 4, 5, 6, 7, 8, ...}

See counting number, zero

width

The measurement from side to side. Also called breadth.

Example

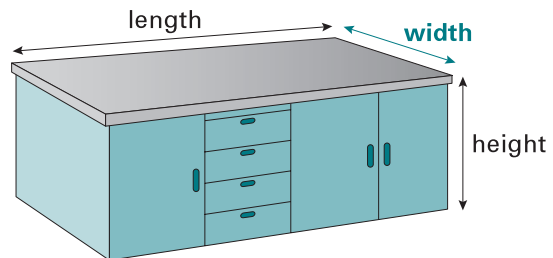

The width of this kitchen bench is 70 cm.



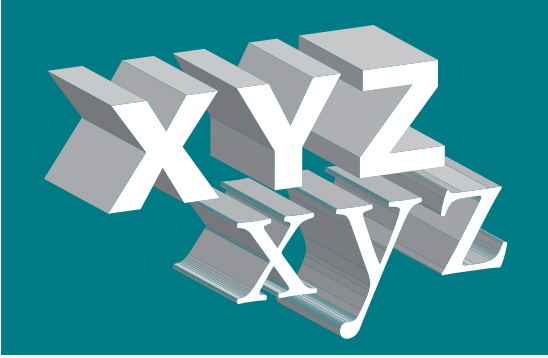

x-axis, y-axis

See coordinates

yard

An imperial measure of length.

$$1 \text{ yard} = 36 \text{ inches} \approx 90 \text{ cm}$$

year

The period of time it takes the Earth to make one complete revolution around the sun: 365 days, 5 hours and $48 \frac{3}{4}$ minutes. The extra hours, minutes and seconds are put together into an extra day every four years to form a 'leap year'.

See day, leap year, revolution

zero

(Symbol: 0, Ø)

The numeral 0 (nought). Nothing.

Rules for working with zero:

1 A number + 0 = same number

$$5 + 0 = 5$$

2 A number - 0 = same number

$$7 - 0 = 7$$

3 A number \times 0 = 0

$$6 \times 0 = 0$$

4 $0 \div$ any number = 0

$$0 \div 10 = 0$$

5 A number \div 0 has no answer

$$3 \div 0 = \text{can't do}$$

The digit zero is used as a place holder in numerals.

Example

In the number sixty, 0 is a place holder for units to show that the 6 means six tens and there are no single units.

Note: These words all mean zero: nil, nought, none, nix, null, oh, void, empty set, zilch, duck (in cricket), love (in tennis).

See digit, place holder

zero power

When working with indices, any number raised to the power zero always equals one. It happens because when we divide indices, we subtract the indexes and get zero.

$$2^0 = 1 \quad 376^0 = 1 \quad x^0 = 1$$

Example

Find the value of:

$$\begin{aligned} 5^2 \div 5^2 & & 5^2 \div 5^2 \\ = 5 \times 5 \div 5 \times 5 & & = 5^{(2-2)} \\ = 25 \div 25 & & = 5^0 \\ = 1 & & = 1 \end{aligned}$$

See index, index laws, power of a number



Useful Information

Units of measurement

length

10 millimetres (mm)	= 1 centimetre (cm)
100 centimetres (cm)	= 1 metre (m)
1000 millimetres (mm)	= 1 metre (m)
1000 metres (m)	= 1 kilometre (km)

area

100 square millimetres (mm ²)	= 1 square centimetre (cm ²)
10 000 square centimetres (cm ²)	= 1 square metre (m ²)
10 000 square metres (m ²)	= 1 hectare (ha)
100 hectares (ha)	= 1 square kilometre (km ²)
	= 1 000 000 square metres (m ²)

mass

1000 milligrams (mg)	= 1 gram (g)
1000 grams (g)	= 1 kilogram (kg)
1000 kilograms (kg)	= 1 tonne (t)

liquid volume

1000 millilitres (mL)	= 1 litre (L)
1 mL (for liquids)	= 1 cm ³ (for solids)
1000 litres (L)	= 1 kilolitre (kL)
1 kL (for liquids)	= 1 m ³ (for solids)

solids volume

1 cubic centimetre (cm ³)
1 cubic metre (m ³)

time

60 seconds (s)	= 1 minute (min)
60 minutes (min)	= 1 hour (h)
24 hours (h)	= 1 day (d)
7 days	= 1 week
365 days	= 1 year
366 days	= 1 leap year
12 months	= 1 year
10 years	= 1 decade
100 years	= 1 century
1000 years	= 1 millenium

symbols

m	metre
g	gram
L	litre
t	tonne
m ²	square metre
m ³	cubic metre
ha	hectare
°C	degree Celsius



Remember: These are the correct symbols.

mm	cm	m	km		
mL	L	kL			
mg	g	kg	t		
mm ²	cm ²	m ²	ha	km ²	
cm ³	m ³				
s	min	h	d		

angle measure

1 degree (1°)	= 60 minutes (60')
1 minute (1')	= 60 seconds (60'')
1 right angle	= 90 degrees (90°)
1 straight angle	= 180 degrees (180°)
1 revolution	= 360 degrees (360°)
1 radian	= approx 57.3 degrees (57.3°).

A list of symbols

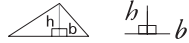
Symbol	Meaning	Example
+	addition sign, add, plus	$2 + 1 = 3$
-	subtraction sign, subtract, take away, minus	$7 - 6 = 1$
×	multiplication sign, multiply by, times	$3 \times 3 = 9$
\div $\overline{)}$	division sign, divide by	$9 \div 2 = 4.5$
=	is equal to, equals	$2 + 2 = 1 + 3$
≠	is not equal to	$2 \neq 5$
$\doteq \approx \cong$	is approximately equal to	$302 \approx 300$
\leq	is less than or equal to	$x \leq 12$
\geq	is greater than or equal to	$5 \geq y$
>	is greater than	$7 > 6.9$
<	is less than	$2 < 4$
\nless	is not less than	$6 \nless 5$
\ngtr	is not greater than	$3.3 \ngtr 3.4$
c	cent(s)	50c
\$	dollar(s)	\$1.20
.	decimal point (on the line)	5.24
%	per cent, out of 100	50%
°	degree Celsius, degree (angle measure)	°C 35 °C 90°
'	minutes (angle measure)	5° 35'
' foot	feet (imperial system)	1' \approx 30 cm
"	seconds (angle measure)	12°05'24"
" inch	inches (imperial system)	12" = 1'
$\sphericalangle \wedge$	angle	$\sphericalangle AOB \widehat{BOC}$
\triangle	triangle	$\triangle ABC$
	parallel lines, is parallel to	$AB \parallel CD$
$\equiv \parallel$	line segments of the same length	
\perp	right angle, 90°	
\perp	is perpendicular to, at 90°	
$\sqrt{\quad}$	square root	$\sqrt{4} = \pm 2$
$\sqrt[3]{\quad}$	cube root	$\sqrt[3]{27} = 3$
π	pi, $\pi \approx 3.14$	$C = 2\pi r$
$\equiv \cong$	is congruent to	$\triangle ABC \equiv \triangle DEF$

Roman numerals



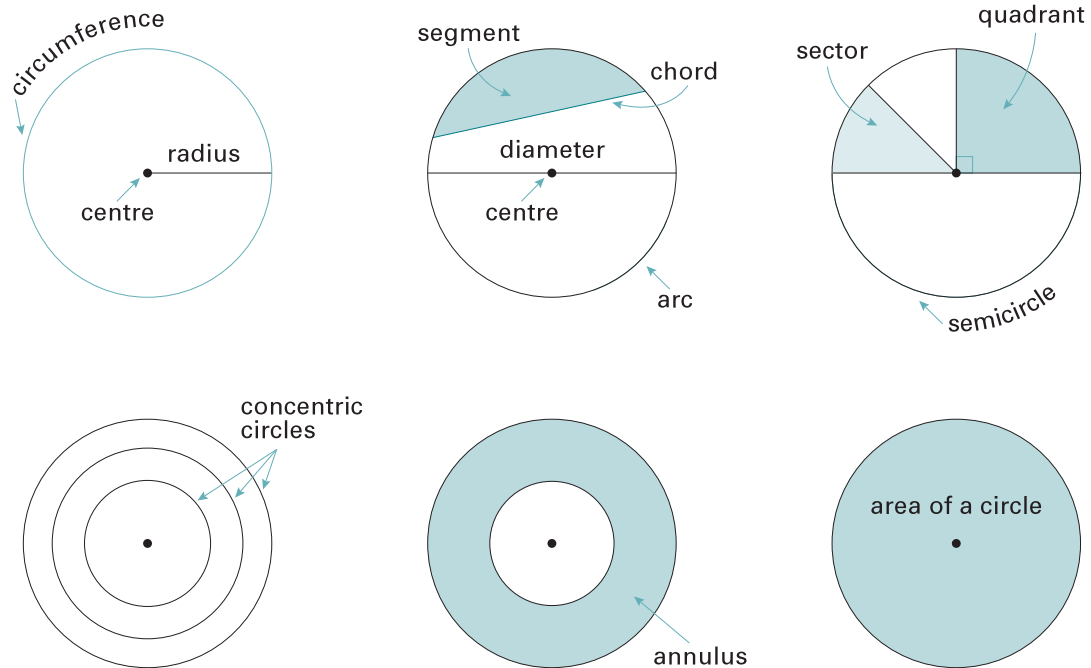

	Thousands	Hundreds	Tens	Units
1	M	C	X	I
2	MM	CC	XX	II
3	MMM	CCC	XXX	III
4		CD	XL	IV
5		D	L	V
6		DC	LX	VI
7		DCC	LXX	VII
8		DCCC	LXXX	VIII
9		CM	XC	IX

Example 2 0 0 7 = MMVII
 ↓ ↓ ↓ ↓
 MM VII

Parts of a circle

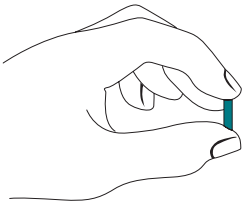
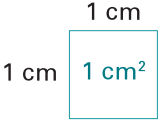
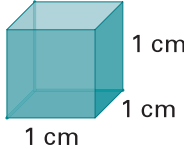
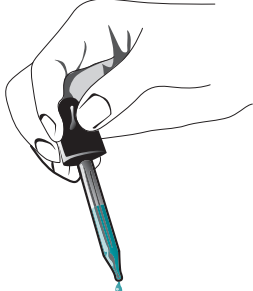
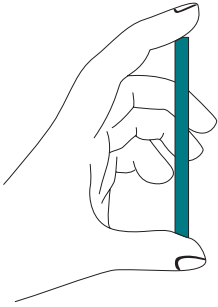
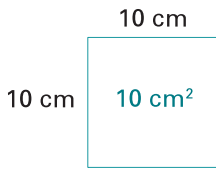
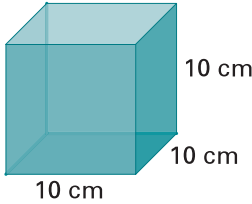
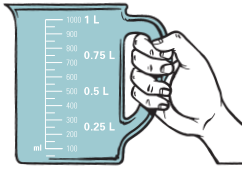

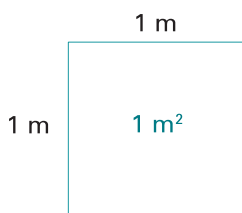
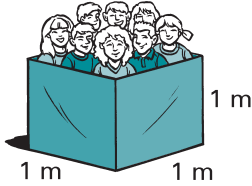
Metric relationships

Length	Area	Volume	Capacity
			
1 cm 10 mm	1 cm^2 100 mm^2	1 cm^3 1000 mm^3	1 mL One 1 cm cube (cubic centimetre) has a capacity of 1 millilitre.
			
10 cm 100 mm	100 cm^2 $10\,000 \text{ mm}^2$	1000 cm^3 $1\,000\,000 \text{ mm}^3$	1 L One 10 cm cube (1000 cm^3) has a capacity of 1 litre.
			
1 m 100 cm	1 m^2 $10\,000 \text{ cm}^2$	1 m^3 $1\,000\,000 \text{ cm}^3$	1 kL One cubic metre has a capacity of 1 kilolitre. These 5 drums each hold 1 kilolitre.

Formulae

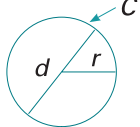
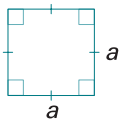
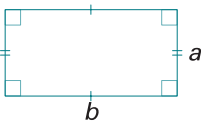
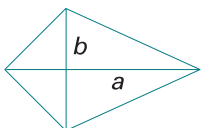
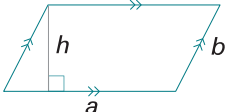
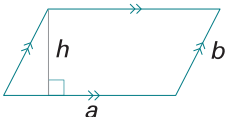
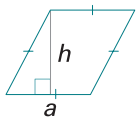
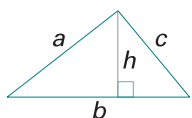
Plane shapes	Diagram	Area	Perimeter
circle		$A = \pi r^2$	$C = 2\pi r = \pi d$
square		$A = a^2$	$P = 4a$
rectangle		$A = ab$	$P = 2(a + b)$
kite		$A = \frac{ab}{2}$	
trapezium		$A = \frac{a + b}{2} \times h$	$P = a + b + c + d$
parallelogram		$A = ah$	$P = 2(a + b)$
rhombus		$A = ah$	$P = 4a$
triangle		$A = \frac{1}{2}bh$	$P = a + b + c$

More formulae

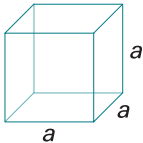
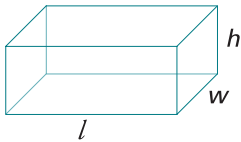
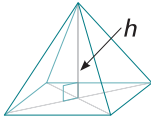
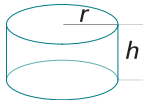
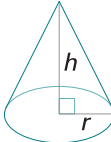
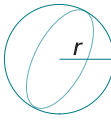
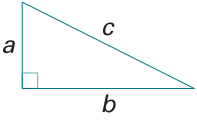
Solids	Diagram	Volume	Surface area
cube		$V = a^3$	$S = 6a^2$
cuboid		$V = lwh$	$S = 2(lw + bl + hw)$
pyramid		$V = \frac{1}{3} \text{base} \times h$	$S = \text{area of base} + 4 \times \text{Area of } \triangle$
cylinder		$V = \pi r^2 h$	$S = 2 \times \pi r^2 + 2\pi r h$ $= 2\pi r (r + h)$
cone		$V = \frac{1}{3} \pi r^2 h$	
sphere		$V = \frac{4}{3} \pi r^3$	$S = 4\pi r^2$
Pythagoras' theorem		$c^2 = a^2 + b^2$ $a = \sqrt{c^2 - b^2}$ $b = \sqrt{c^2 - a^2}$ $c = \sqrt{a^2 + b^2}$	

Large numbers

million	1000×1000	10^6
billion	1000 millions	10^9
trillion	1000 billions	10^{12}
quadrillion	million billions	10^{15}

Letters used in mathematics

in sets

I	integers
N	natural numbers
Q	rational numbers
R	real numbers
W	whole numbers

in geometry

a, b, c, d, \dots	sides of polygons lengths of intervals names of lines
A, B, C, D, \dots	points, vertices
A	area of polygons
b	base of polygons
C	circumference of a circle
d	diameter of a circle
h	height
l	length
O	origin, centre of a circle
P	perimeter
r	radius of a circle
s	side
S, SA	surface area
V	volume of solids
w	width

Decimal system prefixes

Prefix	Symbol	Value	Value in words	Example	Meaning
pico	p	10^{-12}	one trillionth of	1 pF	picofarad
nano	n	10^{-9}	one thousand millionth of	1 ns	nanosecond
micro	μ	10^{-6}	one millionth of	1 μ s	microsecond
milli	m	10^{-3}	one thousandth of	1 mg	milligram
centi	c	10^{-2}	one hundredth of	1 cm	centimetre
deci	d	10^{-1}	one tenth of	1 dB	decibel
unit					
deca	da	10^1	10 times	not commonly used in Australia	
hecto	h	10^2	100 times	1 hL	hectolitre
kilo	k	10^3	1000 times	1 kg	kilogram
mega	M	10^6	1 million times	1 ML	megalitre
giga	G	10^9	1 thousand million times	1 GB	gigabyte

Numerical prefixes

Prefix	Meaning	Example
mono	1	monorail
bi	2	bicycle, binary
tri	3	tricycle, triangle
tetra	4	tetrahedron, tetrapack
quad	4	quadrilateral, quads
penta, quin	5	pentagon
hexa	6	hexagon
hepta, septi	7	heptagon
octa	8	octagon
nona, non	9	nonagon
deca	10	decagon, decahedron
undeca	11	undecagon
dodeca	12	dodecagon, dodecahedron
icosa	20	icosahedron
hect	100	hectare
kilo	1000	kilogram
mega	1 000 000	megalitre, megawatt
giga	1000 million	gigabyte

Other prefixes

Prefix	Meaning	Example
anti	opposite, against	anti clockwise
circum	around	circumference
co	together	cointerior, coordinate
geo	earth	geometry
hemi	half	hemisphere
macro	very big	macrocosmos
micro	very small	microbe
multi	many, much	multibase blocks
peri	around	perimeter
poly	many	polygon
semi	half	semicircle
sub	below, under	subset
trans	across, beyond, over	transversal
uni	one, having one	unit

The multiplication square

×	1	2	3	4	5	6	7	8	9	10
1	1	2	3	4	5	6	7	8	9	10
2	2	4	6	8	10	12	14	16	18	20
3	3	6	9	12	15	18	21	24	27	30
4	4	8	12	16	20	24	28	32	36	40
5	5	10	15	20	25	30	35	40	45	50
6	6	12	18	24	30	36	42	48	54	60
7	7	14	21	28	35	42	49	56	63	70
8	8	16	24	32	40	48	56	64	72	80
9	9	18	27	36	45	54	63	72	81	90
10	10	20	30	40	50	60	70	80	90	100

Greek alphabet

The letters of the Greek alphabet are used as symbols for angles, mathematical operations, etc.

Examples

$\alpha, \beta, \gamma, \delta, \dots \pi \dots$

Σ sum

∞ infinity

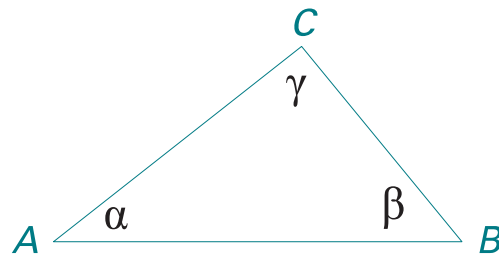

Capital	Lower case	Handwritten	Pronunciation
A	α	α	alpha
B	β	β	beta
Γ	γ	γ	gamma
Δ	δ	δ	delta
E	ϵ	ϵ	epsilon
Z	ζ	ζ	zeta
H	η	η	eta
Θ	θ	θ	theta
I	ι	ι	iota
K	κ	κ	kappa
Λ	λ	λ	lambda
M	μ	μ	mu
N	ν	ν	nu
Ξ	ξ	ξ	xi
O	\omicron	\omicron	omicron
Π	π	π	pi
P	ρ	ρ	rho
Σ	σ	σ	sigma
T	τ	τ	tau
Υ	υ	υ	upsilon
Φ	ϕ	ϕ	phi
X	χ	χ	chi
Ψ	ψ	ψ	psi
Ω	ω	ω	omega

Conversion tables: metric and imperial

length

Metric		Imperial
1 mm		0.03937 in
1 cm	10 mm	0.3937 in
1 m	100 cm	1.0936 yd
1 km	1000 m	0.6214 mile

Imperial		Metric
1 in		2.54 cm
1 ft	12 in	0.3048 m
1 yd	3 ft	0.9144 m
1 mile	1760 yd	1.6093 km
1 nautical mile	2025.4 yd	1.853 km

area

Metric		Imperial
1 cm ²	100 mm ²	0.155 in ²
1 m ²	10 000 cm ²	1.1960 yd ²
1 ha	10 000 m ²	2.4711 acres
1 km ²	100 ha	0.3861 mile ²

Imperial		Metric
1 in ²		6.4516 cm ²
1 ft ²	144 in ²	0.0929 m ²
1 yd ²	9 ft ²	0.8361 m ²
1 acre	4840 yd ²	4046.9 m ²
1 mile ²	640 acres	2.59 km ²

mass

Metric		Imperial
1 mg		0.0154 grain
1 g	1000 mg	0.0353 oz
1 kg	1000 g	2.2046 lb
1 t	1000 kg	0.9842 ton

Imperial		Metric
1 oz	437.5 grain	28.35 g
1 lb	16 oz	0.4536 kg
1 stone	14 lb	6.3503 kg
1 hundredweight (cwt)	112 lb	50.802 kg
1 long ton	20 cwt	1.016 t

volume

Metric		Imperial
1 cm ³		0.0610 in ³
1 dm ³ (decimetre)	1000 cm ³	0.0353 ft ³
1 m ³	1000 dm ³	1.3080 yd ³
1 L	1 dm ³	1.76 pt (pint)
1 hL (hectolitre)	100 L	21.997 gal

Imperial		Metric
1 in ³		16.387 cm ³
1 ft ³	1728 in ³	0.0283 m ³
1 fl oz (fluid ounce)		28.413 mL
1 pt	20 fl oz	0.5683L
1 gal	8 pt	4.5461L

temperature

to convert from Celsius
to Fahrenheit:

$$F = \frac{9}{5} \times \text{Celsius} + 32$$

To convert from Fahrenheit
to Celsius:

$$C = \frac{5 (\text{Fahrenheit} - 32)}{9}$$

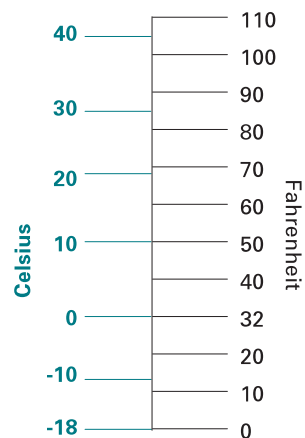

Computing terms

bit

The smallest representation of computer storage. A bit can be either a 0 (off) or 1 (on). A bit represents the electrical state of a circuit on a motherboard (i.e. on or off).

See byte

Boolean function

Mathematical logic used for searching computer databases. Common Boolean functions include AND, OR and NOT.

Example

Database Search: first name = 'John' AND age = '20'

This will only return all people with the first name of John who are aged 20.

Database Search: first name = 'John' OR age = '20'

This will return all people with the first name of John and all people who are aged 20.

Database Search: first name = 'John' NOT age = '20'

This will return all people with the first name of John who are not 20 years old.

byte

A measurement of computer-based storage and also representation of computer data.

1 byte = 8 bits

Example

10011101 = 1 byte (computer-based storage)

10011101 = 157 (computer data)

See bit, kilobyte

CPU

(Central Processing Unit)

The central part of the computer which controls all of the processing of data. It is situated on the motherboard of a computer system and its speed is measured in hertz.

See hertz, kilohertz, megahertz, gigahertz

flowchart

A method of describing an algorithm using symbols.

Symbols used:

Terminal – to begin and end the flowchart

Process – an action or step

Decision – alternate options or pathways

Flowline – used to connect symbols together and to describe the path of the algorithm

See algorithm

gigabyte (Gb)

A measurement of computer-based storage.

1 gigabyte = 1024 megabytes

See bit, byte, kilobyte, megabyte, terabyte

gigahertz (GHz)

One billion cycles or electrical pulses per second of a computer CPU.

1 GHz = 1000 MHz = 1 000 000

Kz = 1 000 000 000 Hz

See CPU, hertz, kilohertz, megahertz

hertz

(Hz)

A measurement of clock speed of a computer CPU. It is also used to measure sound frequencies for hearing aids and radio transmission.

1 hertz = 1 cycle or electrical pulse of a CPU per second

See CPU, megahertz, gigahertz

hexadecimal

Containing 16 parts or digits. It is a base 16 number system that is made up of 16 digits. The digits represented by this number system are 0 to 9 and then A to F. This number system is used primarily by computer systems, particularly by the programming languages that control computer hardware. It is also the number system used to represent colours on web pages.

Example

Digits represented:

0, 1, 2, 3, 4, 5, 6, 7, 8, 9

A = 10

B = 11

C = 12

D = 13

E = 14

F = 15

See binary, decimal, octal

kilobyte

(Kb)

A measurement of computer-based storage.

1 kilobyte = 1024 bytes

See bit, byte, megabyte

kilohertz

(KHz)

One thousand cycles or electrical pulses per second of a computer CPU.

1 KHz = 1000 Hz

See CPU, hertz, gigahertz

megabyte

(Mb)

A measurement of computer-based storage.

1 megabyte = 1024 kilobytes

See bit, byte, kilobyte, gigabyte

megahertz

(MHz)

One million cycles or electrical pulses per second of a computer CPU.

1 MHz = 1000 KHz = 1 000 000 Hz

See CPU, hertz, kilohertz

octal

Containing 8 parts or digits. It is a base 8 number system that is made up of 8 digits. The digits represented by this number system are 0 to 7. This number system is used primarily by computer systems, particularly by certain programming languages.

Example

Digits represented: 0, 1, 2, 3, 4, 5, 6, 7

See binary, decimal, hexadecimal

RAM

(Random Access Memory)

The primary memory of a computer system. When a computer system is turned off, all contents in RAM are lost. The capacity of RAM is measured in bytes.

See byte, kilobyte, megabyte, gigabyte, terabyte

resolution

A measurement of the quality of a digital image. It is calculated by multiplying the number of dots (pixels) horizontally of the image by the number of dots (pixels) vertically of the image.

Example

Resolution of an image with 1024 horizontal pixels by 768 vertical pixels:

Resolution = $1024 \times 768 = 786\,432$ pixels

1 000 000 pixels = 1 megapixel

terabyte

(Tb)

A measurement of computer-based storage.

1 terabyte = 1024 gigabytes

See bit, byte, kilobyte, megabyte, gigabyte

