

PAPER ANIMALS

ROBERT J. LANG

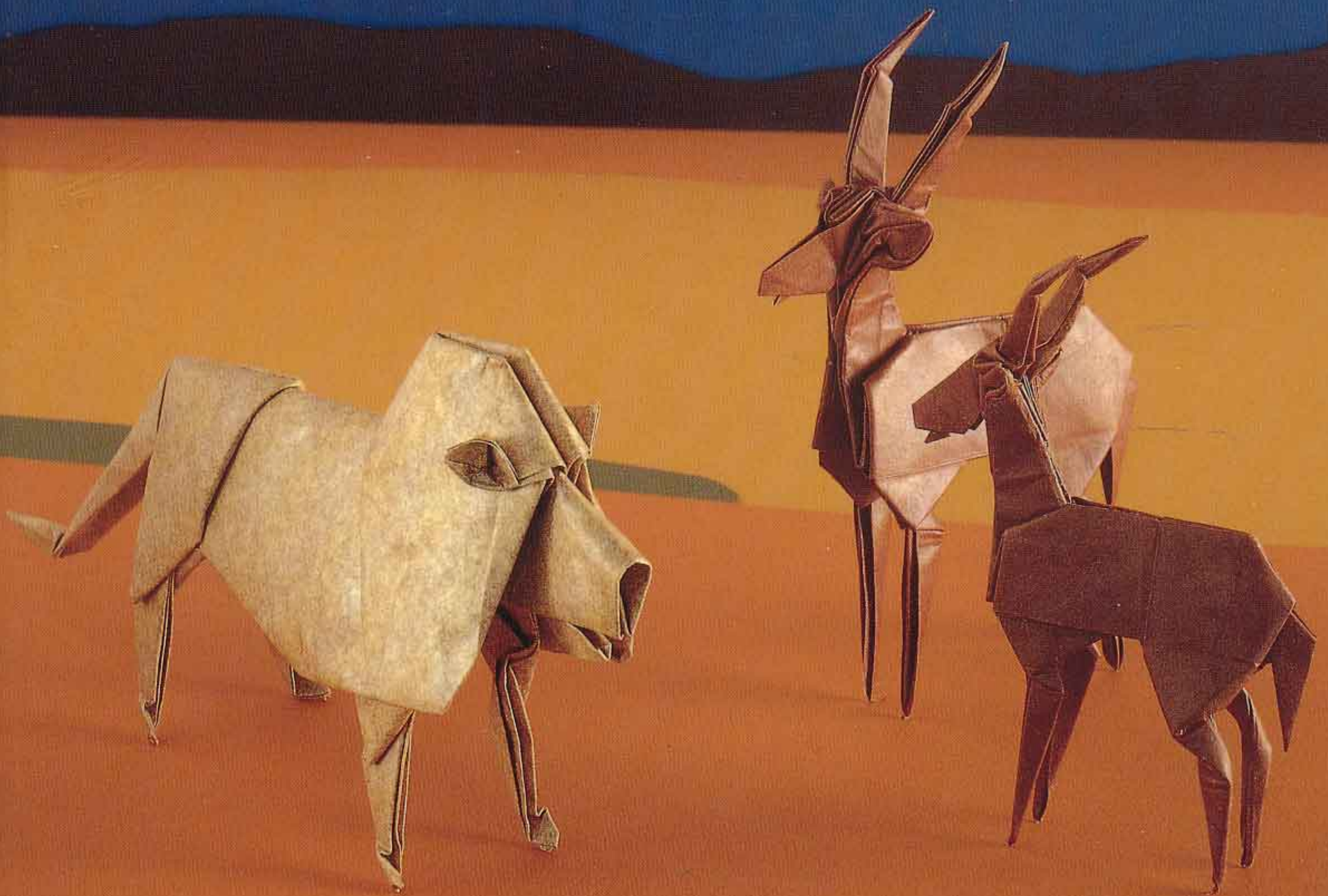

FROM BUTTERFLIES TO BEARS, GRASSHOPPERS TO GAZELLES –
CLASSIC ORIGAMI PROJECTS FROM THE WORLD'S DIVERSE NATURAL HABITATS

Contents

Introduction 6

Paper 8

Symbols and Terms 10

American Meadow 27

Swiss Alp 36

Louisiana Bayou 46

Ocean 60

Arctic Ice 68

Australian Forest 81

African Savanna 95

Acknowledgements and Sources 112

◆ American meadow ◆

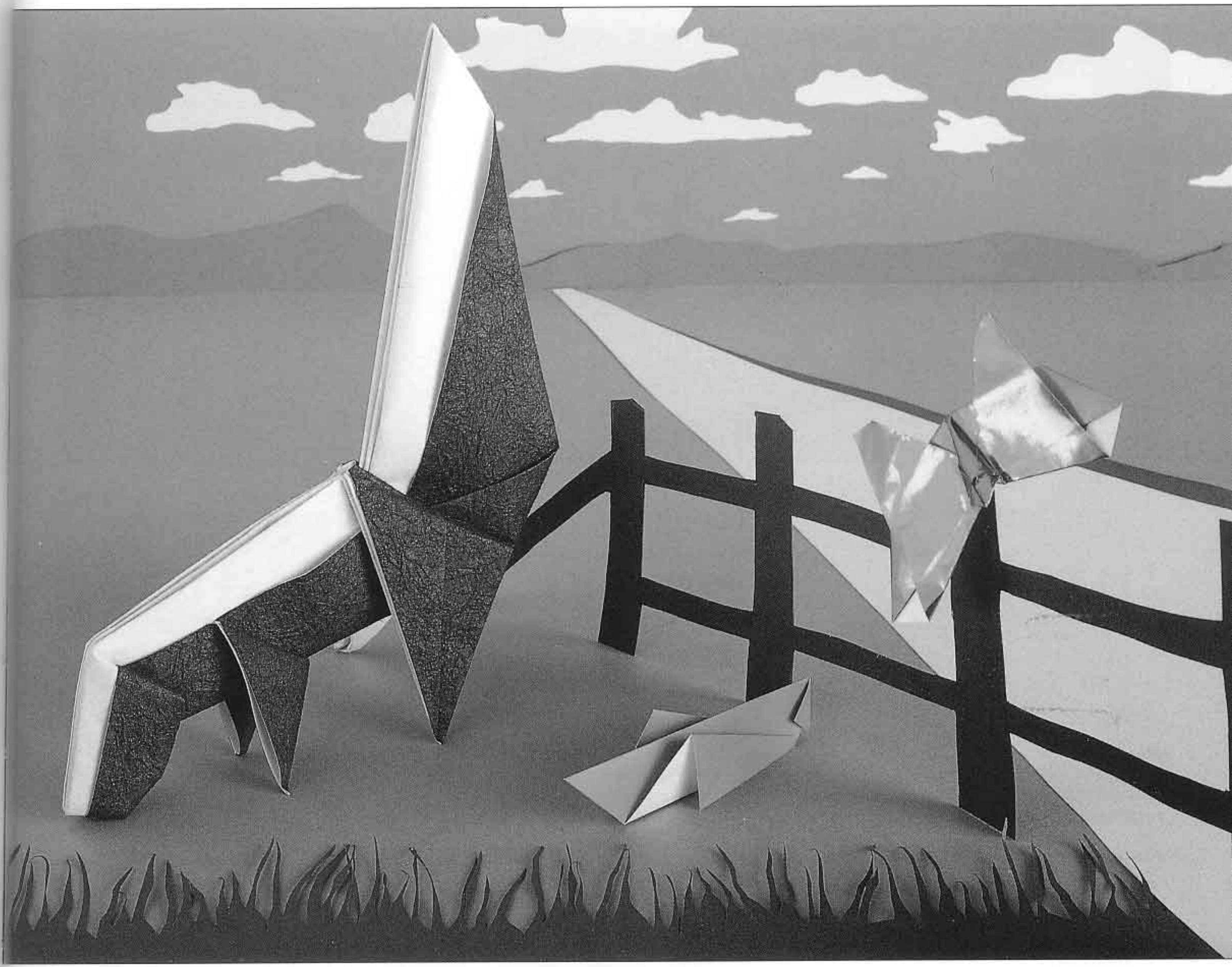

For this project, you will fold the following models:

Name	Page	Rating	Paper requirements
Grasshopper	28	Easy	4 in (10 cm) square of crisp, brightly colored paper
Butterfly	30	Easy	6 in (15 cm) square of thin, crisp paper
Skunk	32	High Intermediate	18 in (45 cm) square of thin paper, black on one side

◆ grasshopper ◆

designed by Gay Merrill Gross

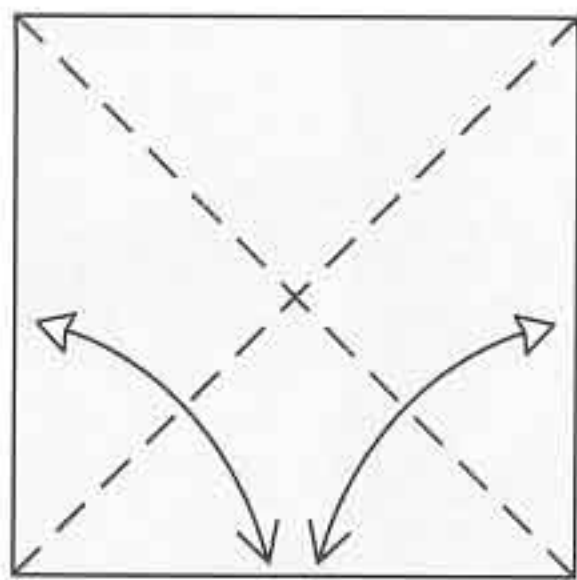
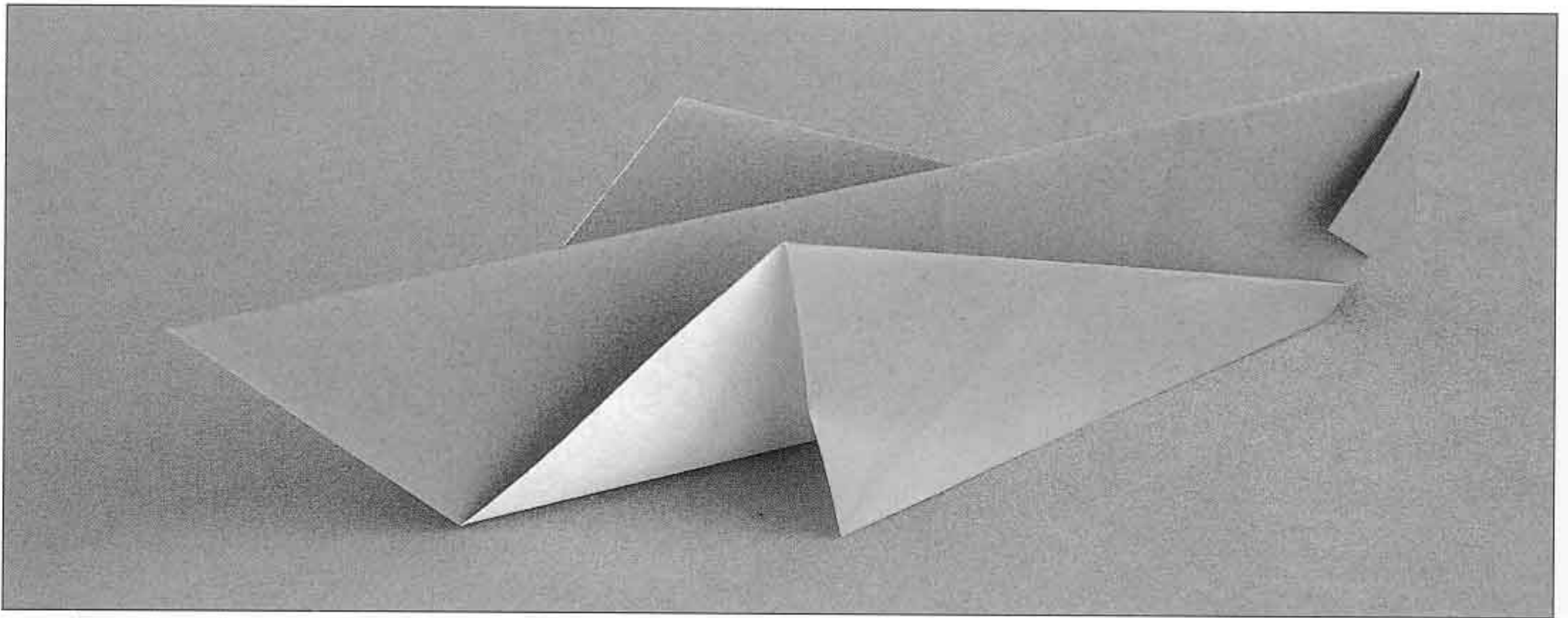

1 Begin with the white side up. Crease the diagonals and turn the paper over.

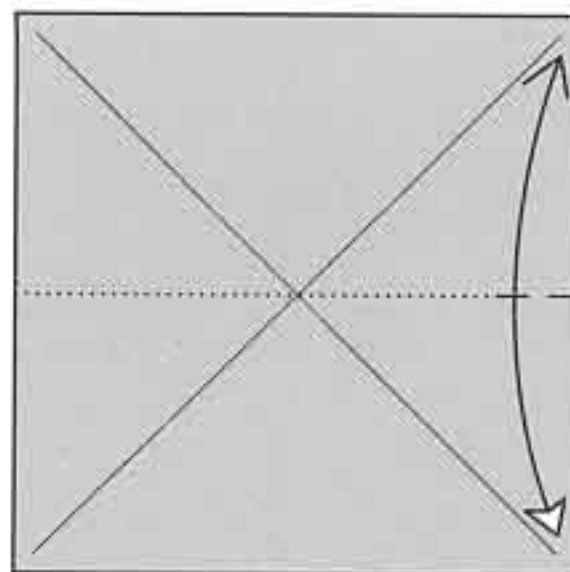
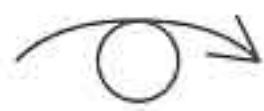

2 Fold the bottom right corner up to the top. Make a small pinch at the right edge and unfold.

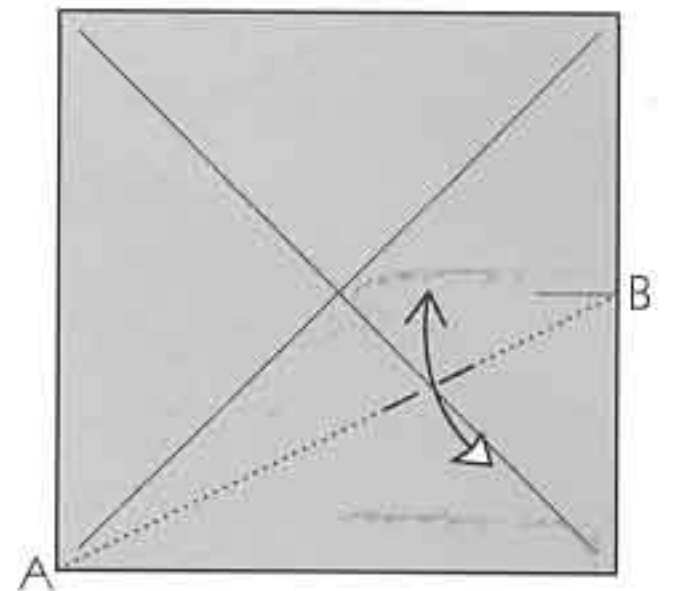

3 Make a crease that runs from A to B, making it sharp only where it crosses the diagonal crease.

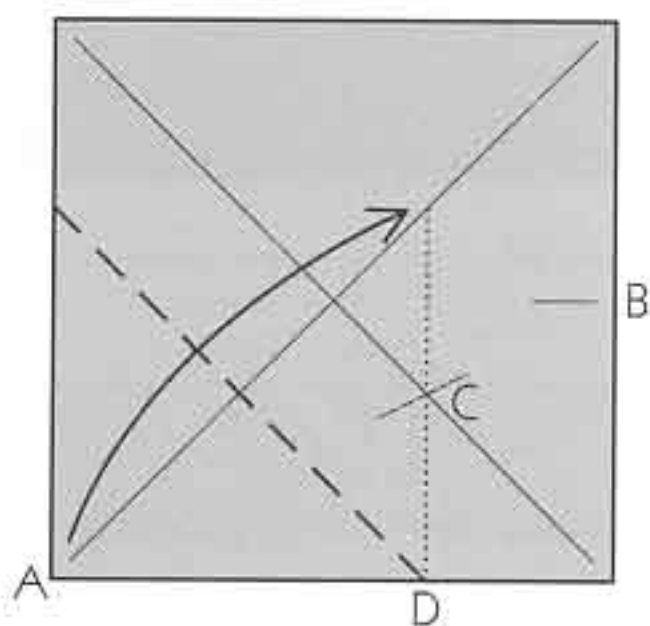

4 Fold up corner A to lie on the diagonal crease so that edge AD runs through point C.

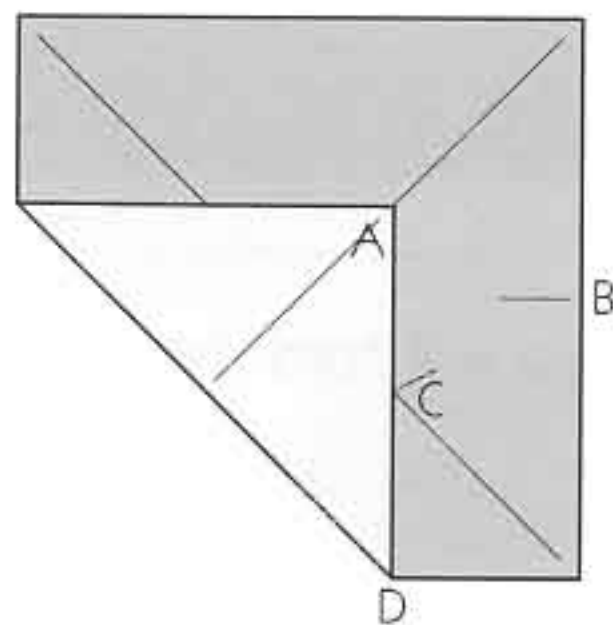

5 Turn over the paper.

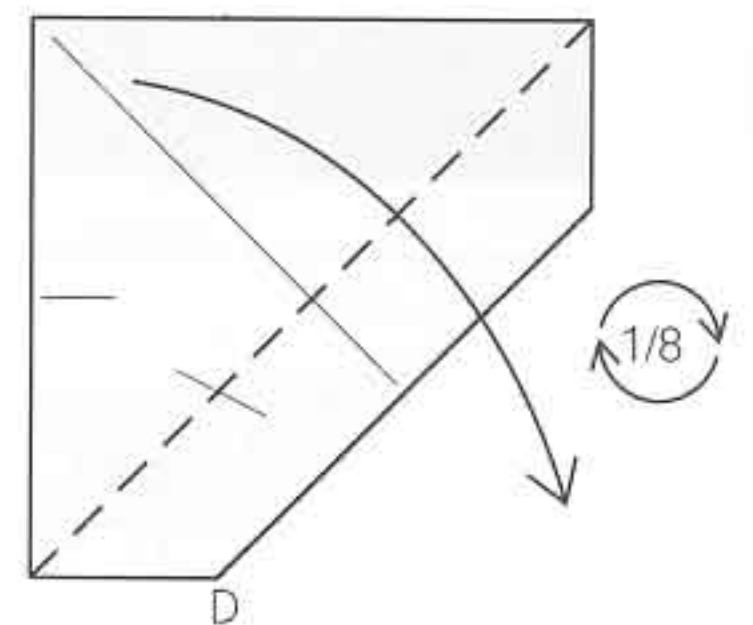
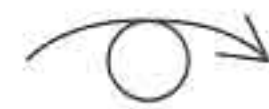

6 Fold down the top left corner. Rotate the paper 1/8 turn.

grasshopper

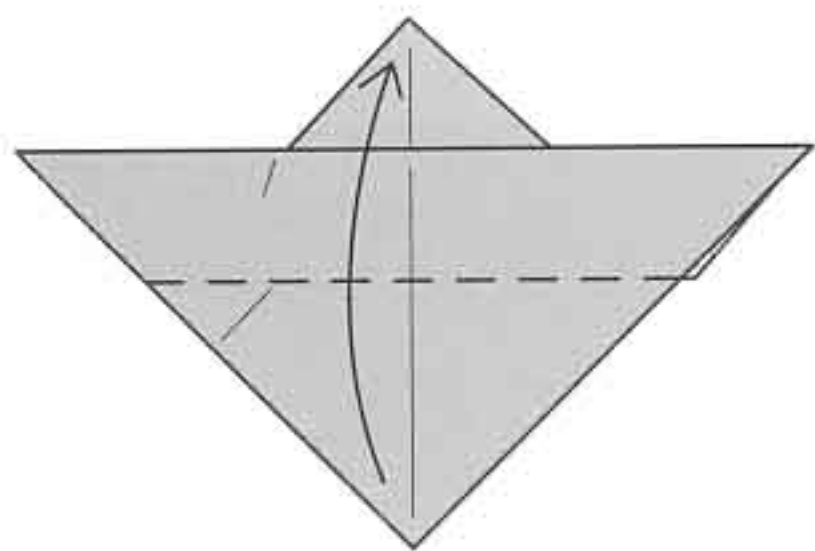

7 Fold the bottom corner up to match the top corner.

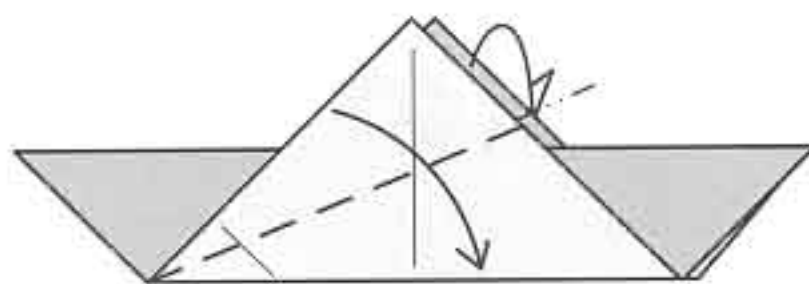

8 Fold down the near flap so that its edge lies along the bottom edge of the model. Repeat behind.



9 Fold the left point over and unfold.

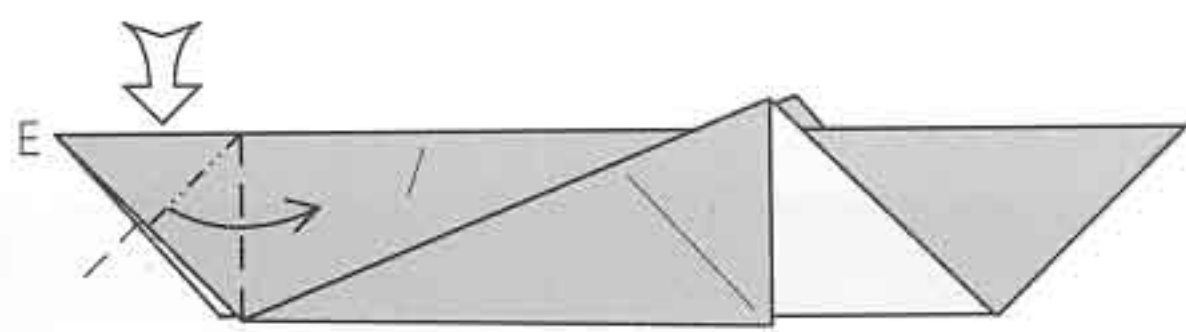

10 Squash-fold point E.

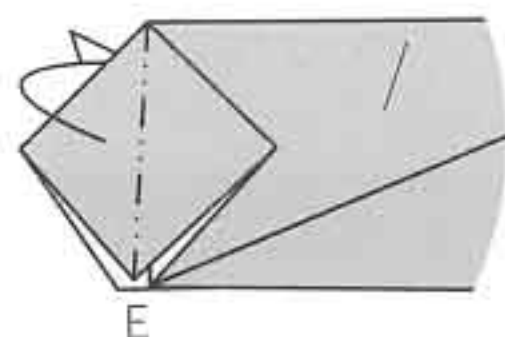

11 Fold one layer behind.

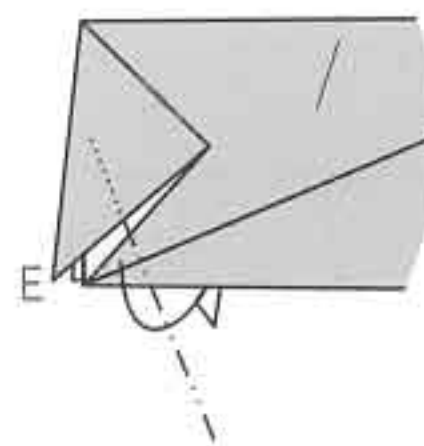

12 There are two corners trapped under point E. Mountain-fold each of them to the inside.

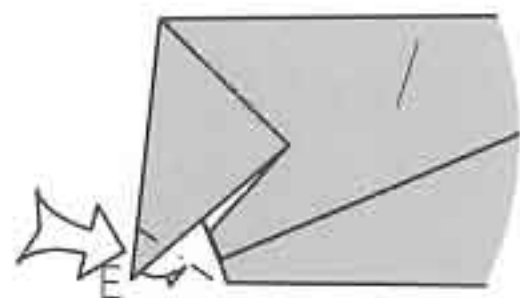

13 Reverse-fold the tip of the head.

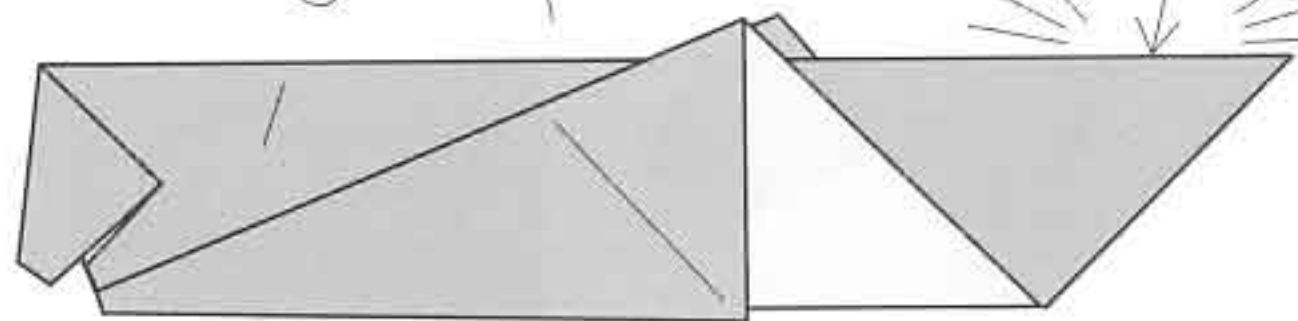
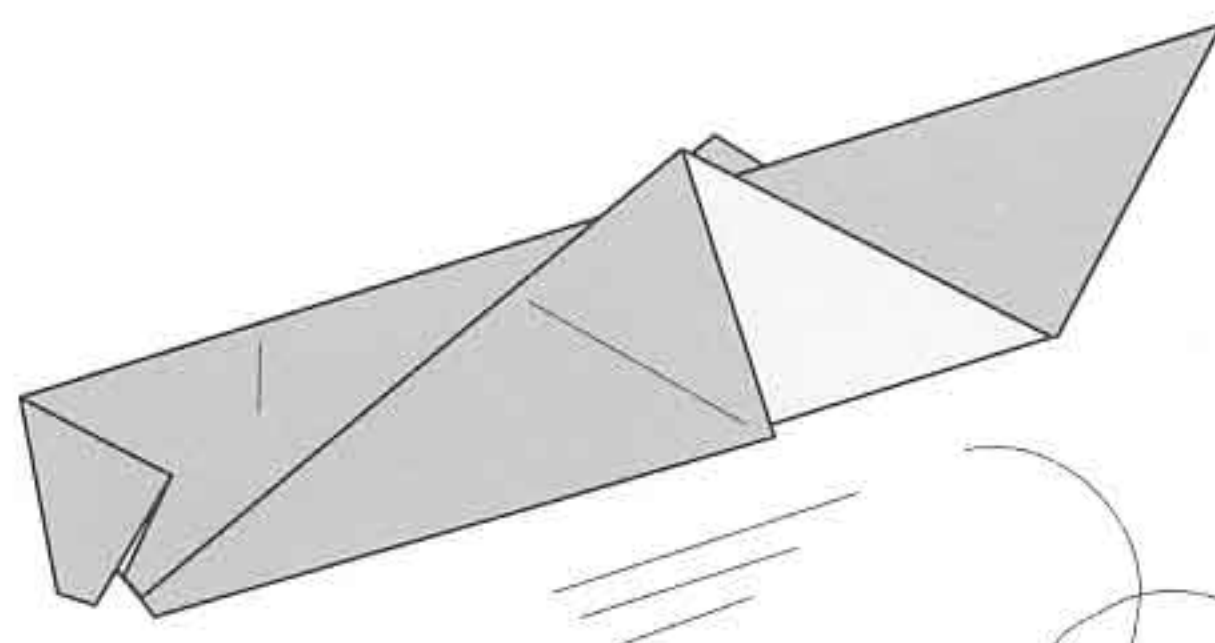

Finished Grasshopper. Tap sharply on his tail to make him jump.

◆ butterfly ◆

designed by Gay Merrill Gross

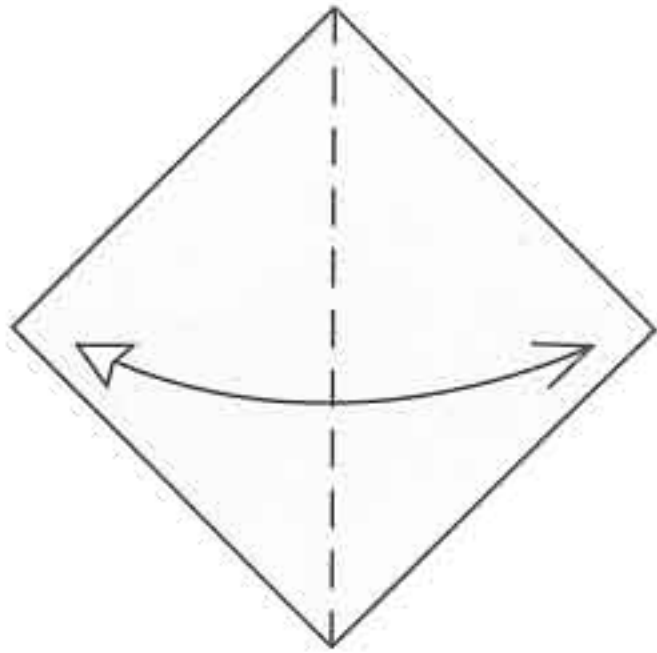

1 Begin with the white side up. Fold the paper in half along one diagonal and unfold.

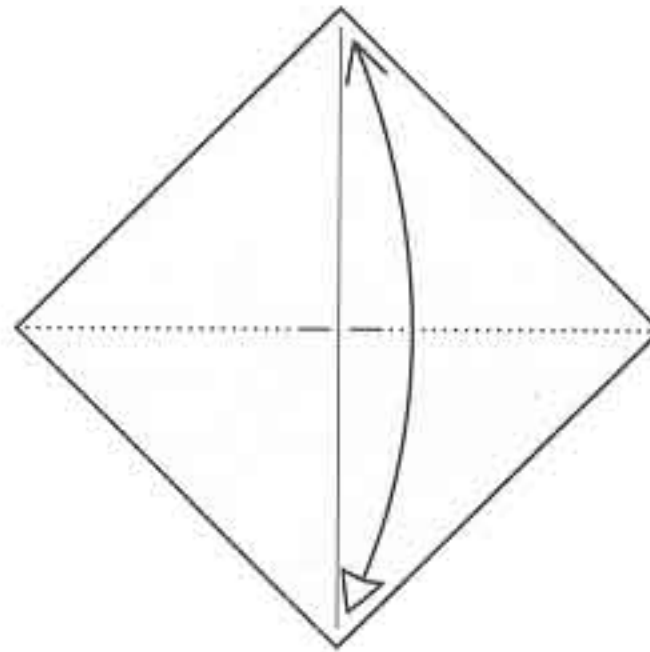

2 Fold the bottom point up to the top point; pinch in the middle and unfold.

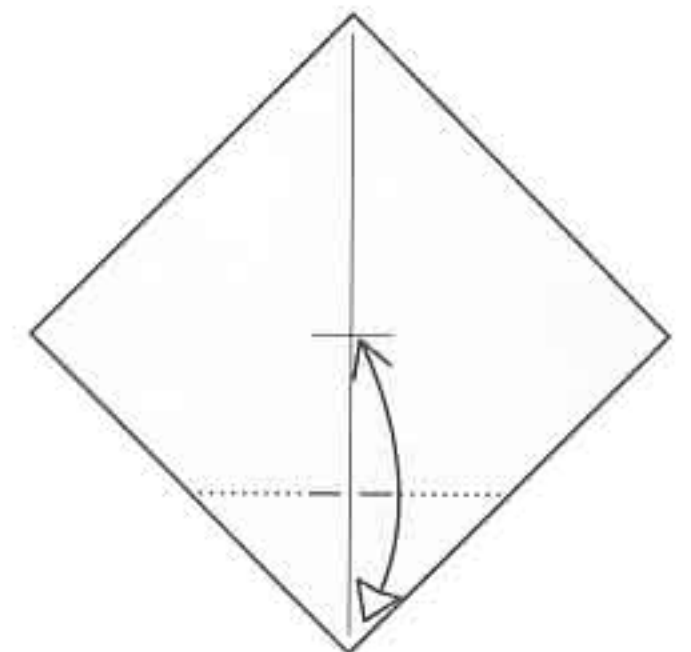

3 Fold the bottom point up to the crease you just made; pinch in the middle and unfold.

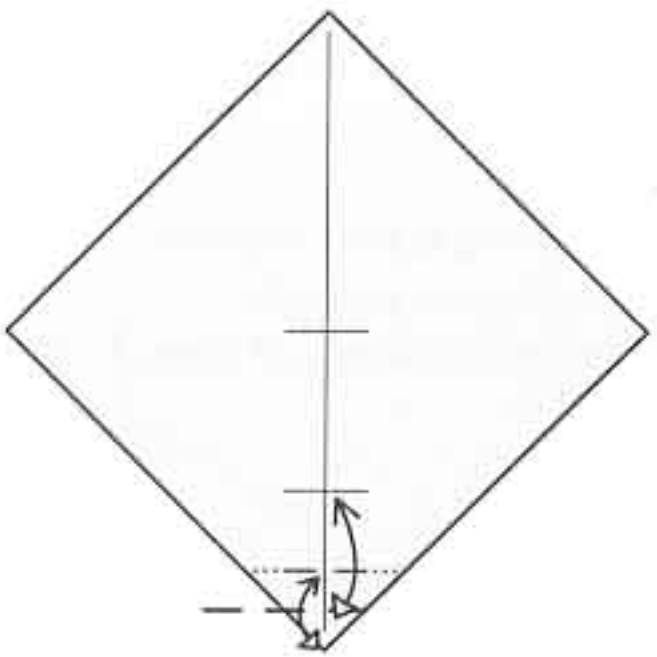

4 Repeat step 3 two more times.

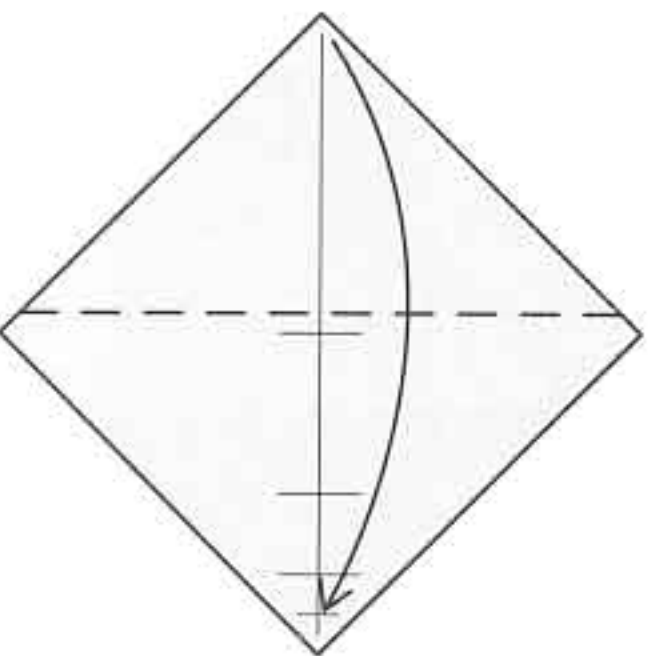

5 Now fold the top point down to the last crease and leave it in place.

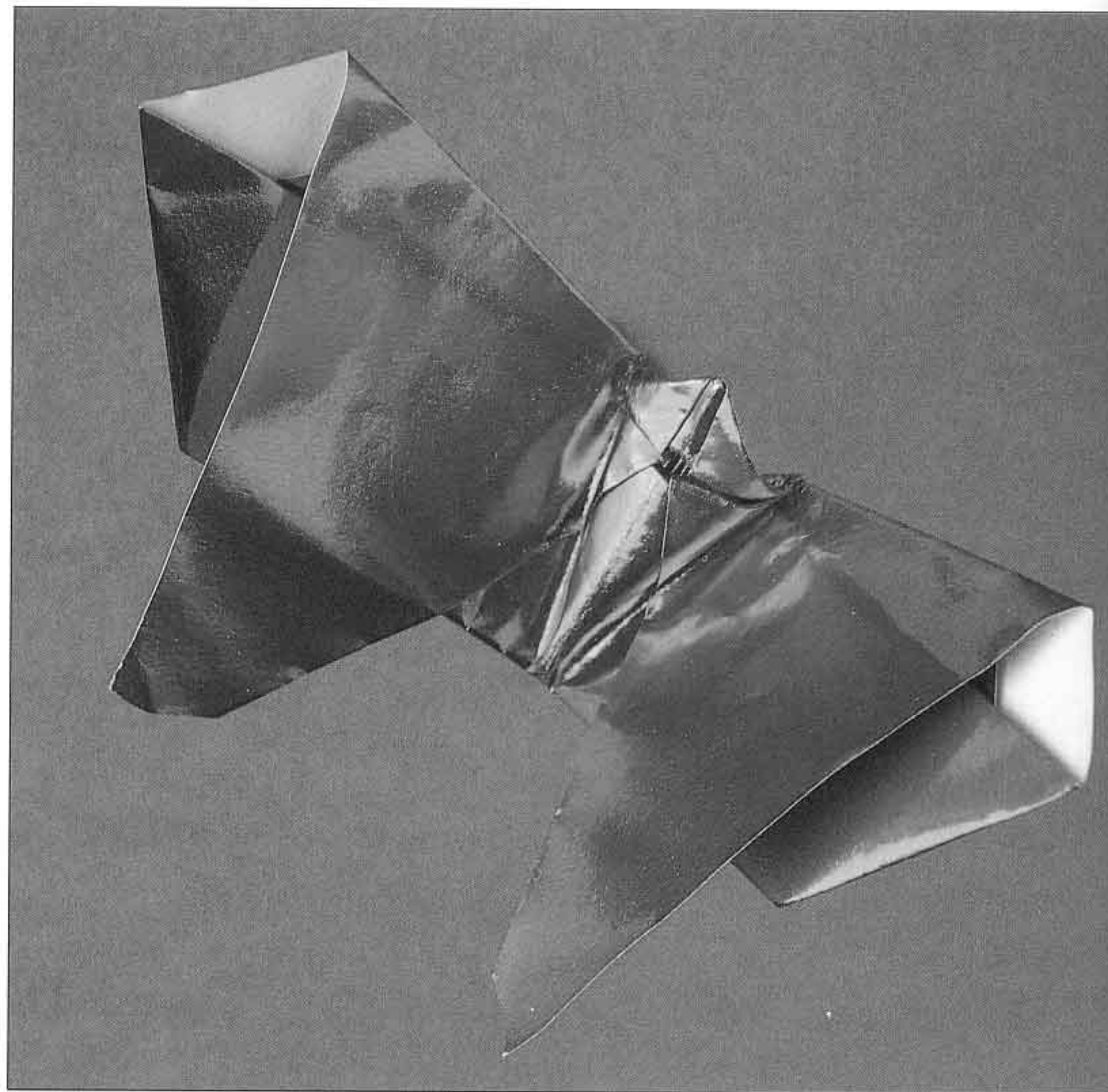

butterfly

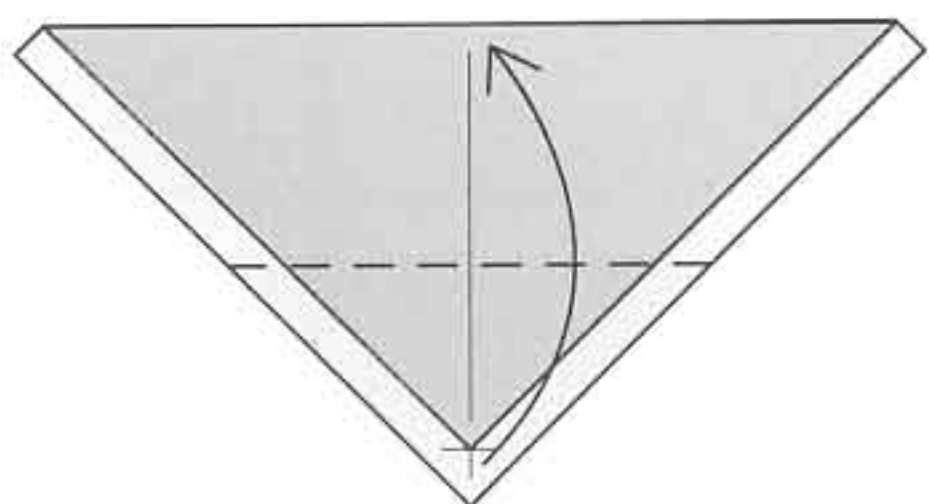

6 Fold both layers together so the bottom point comes up to touch the top edge in the middle.

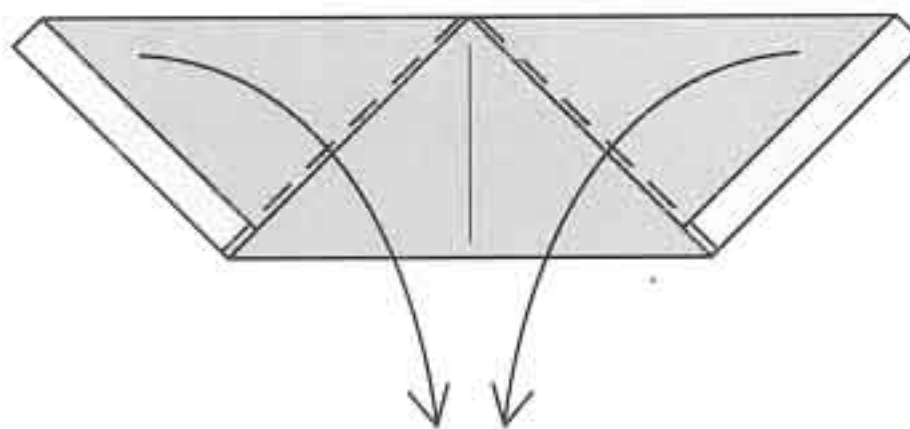

7 Fold the left and right corners down so that their edges meet in the middle.

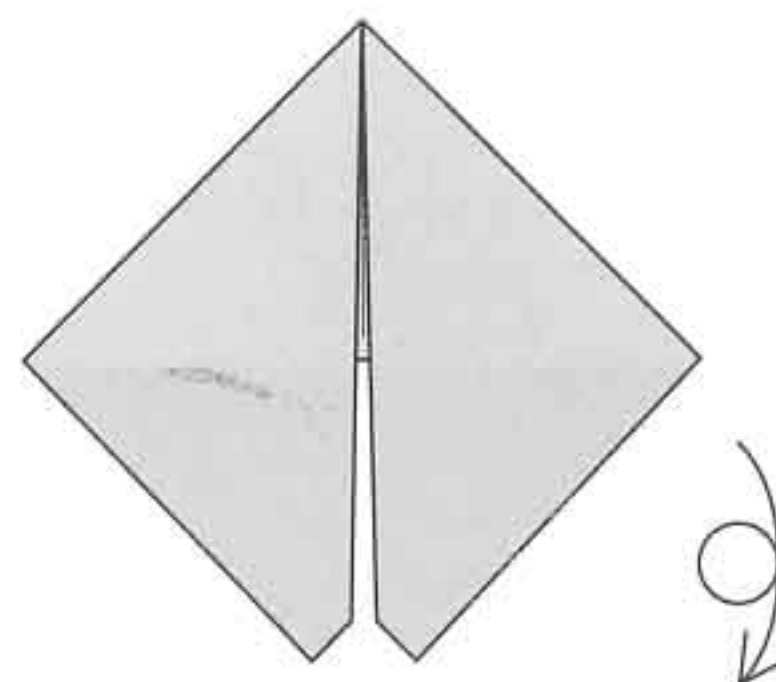

8 Turn the model over from top to bottom.

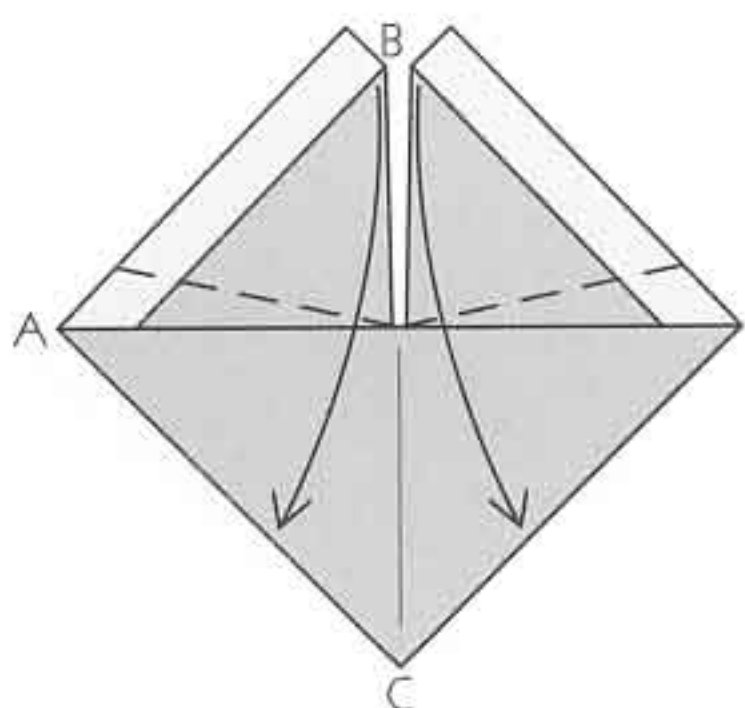

9 Fold down corner B to lie on edge AC. Repeat on the right.

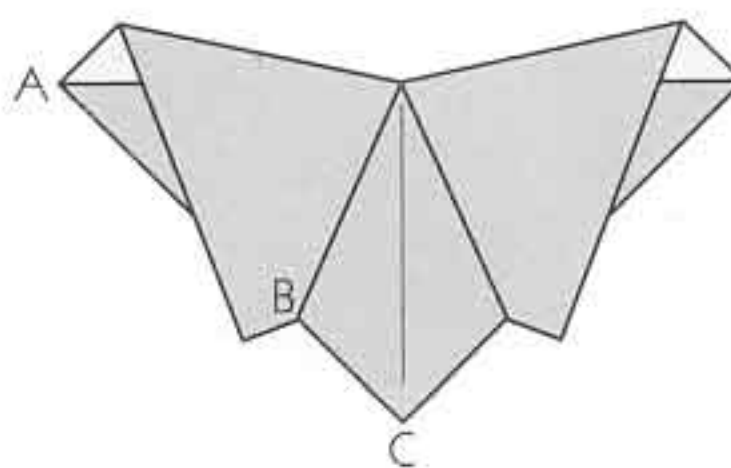

10 Turn over the paper.

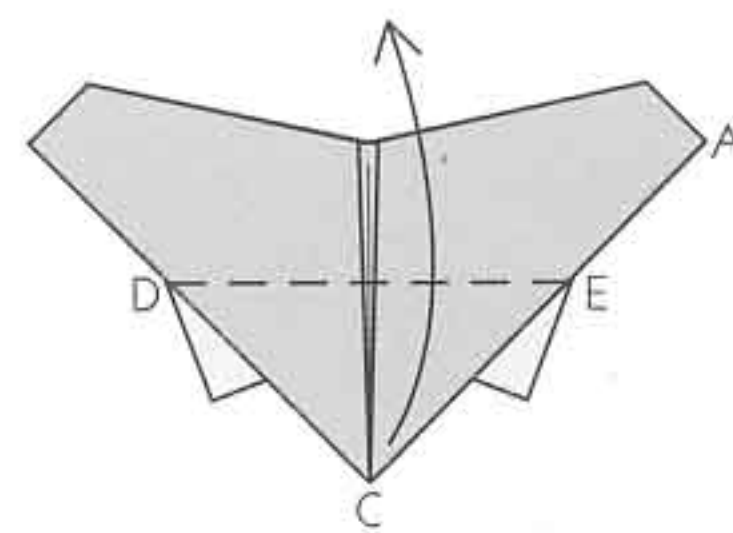

11 Fold corner C up. Note that the crease runs between points D and E, each of which lies at the intersection of two edges.

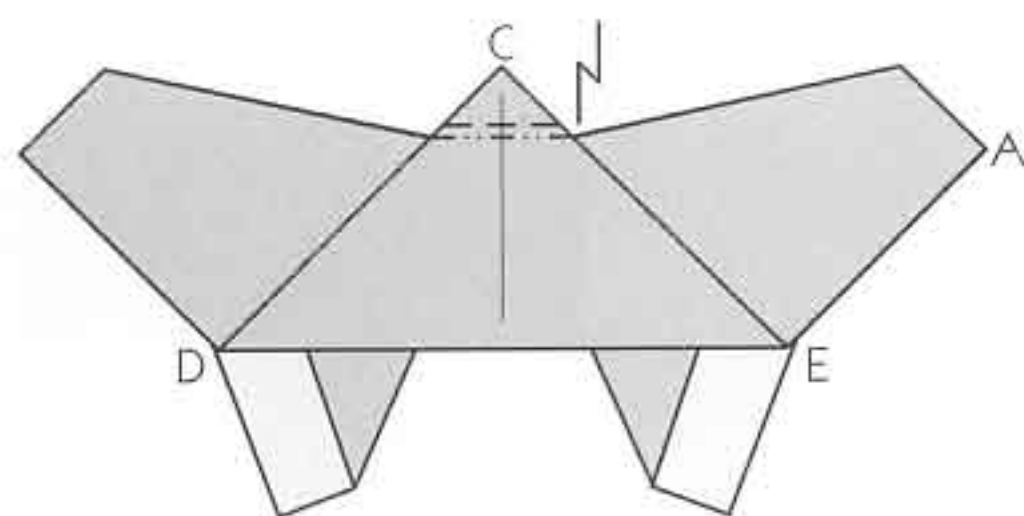

12 Pleat the top corner. Note that the bottom fold is the mountain fold.

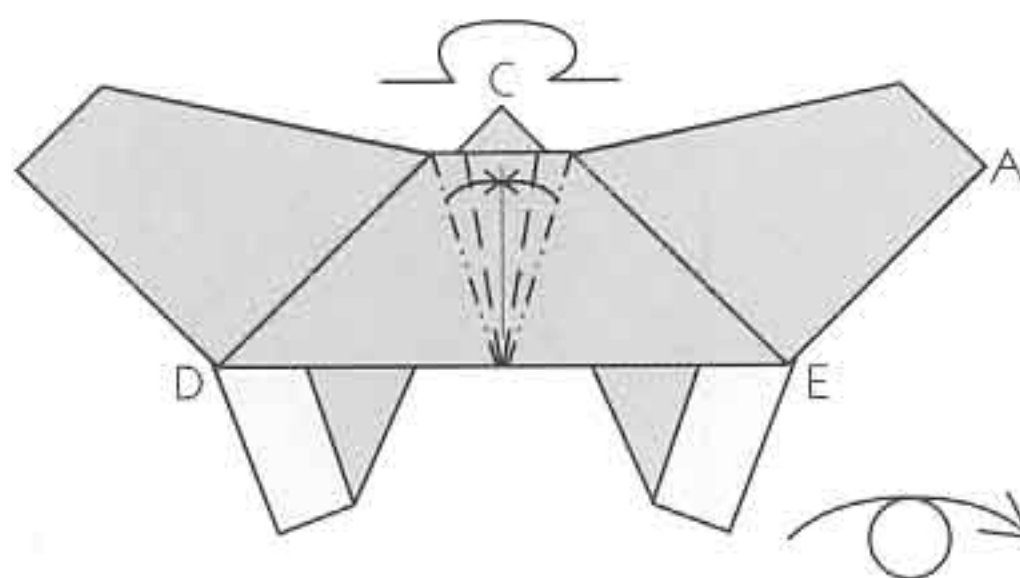

13 Pleat the body on each side, leaving the valley folds slightly rounded. Curling the body around a pencil helps. Turn the model over.

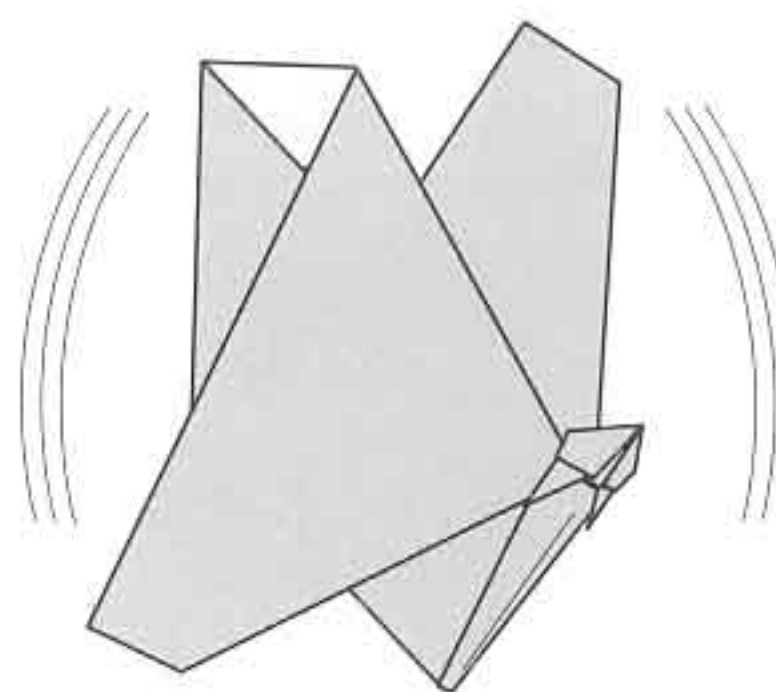

Finished Butterfly.

◆ skunk ◆

designed by Aaron Einbond

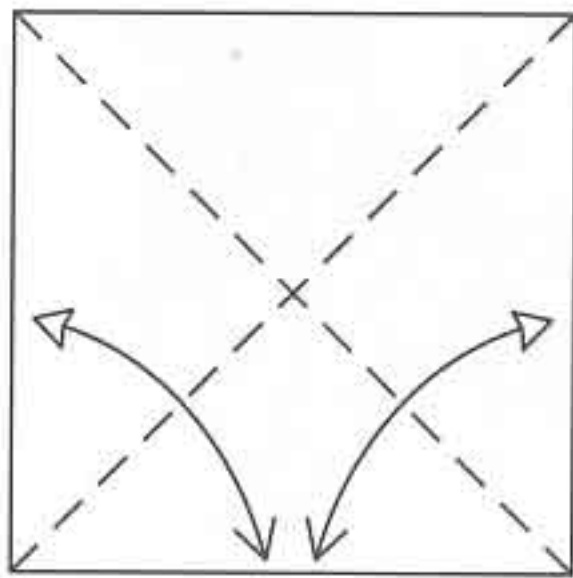
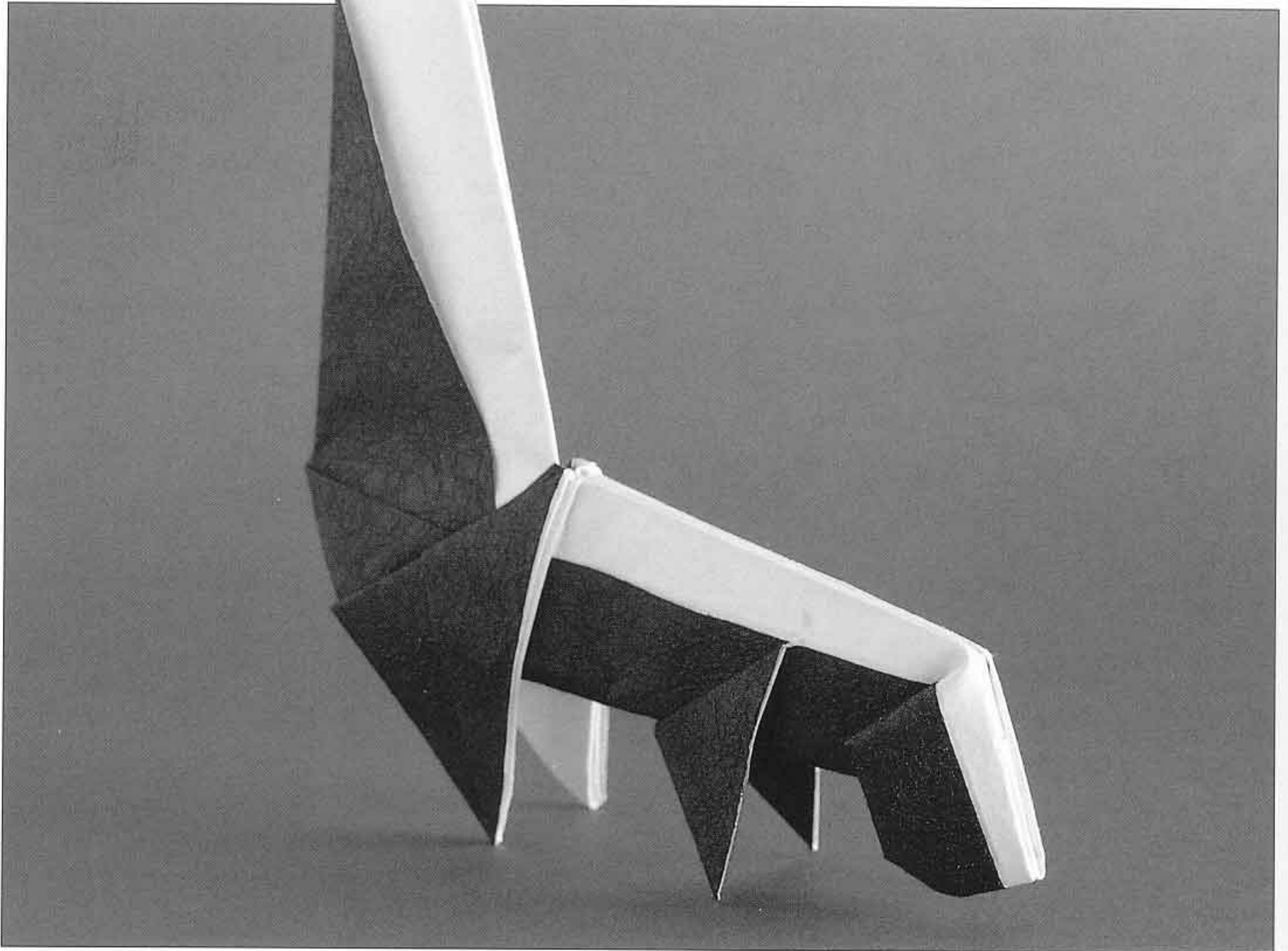

1 Begin with the white side up. Fold and unfold both diagonals.

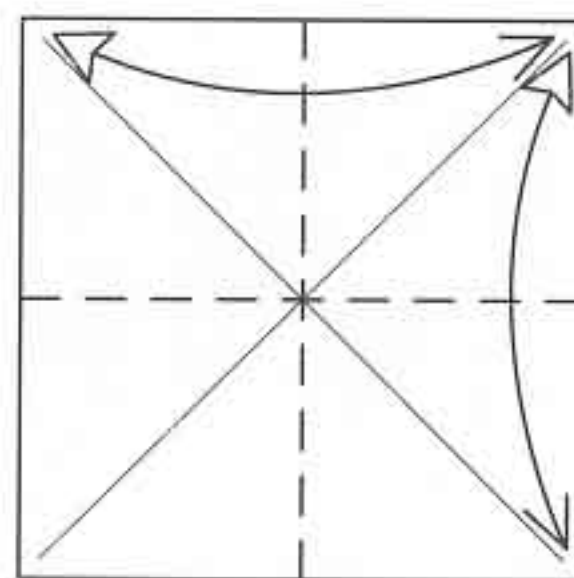

2 Fold and unfold vertically and horizontally. Turn the paper over.

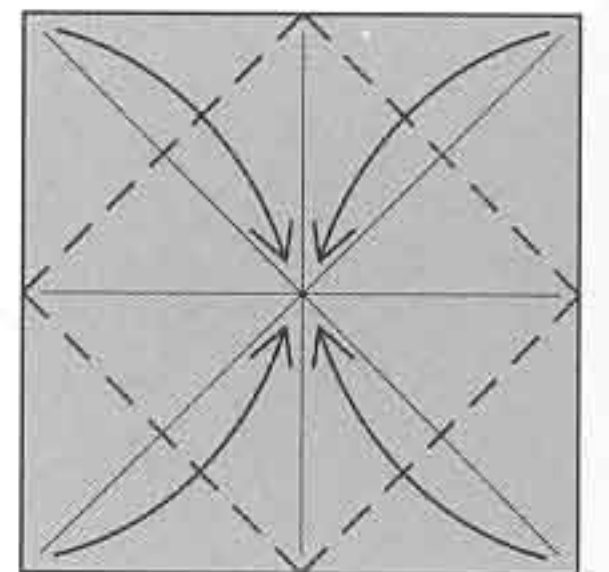
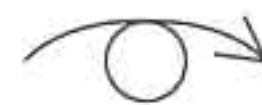

3 Fold the corners to the center.

skunk

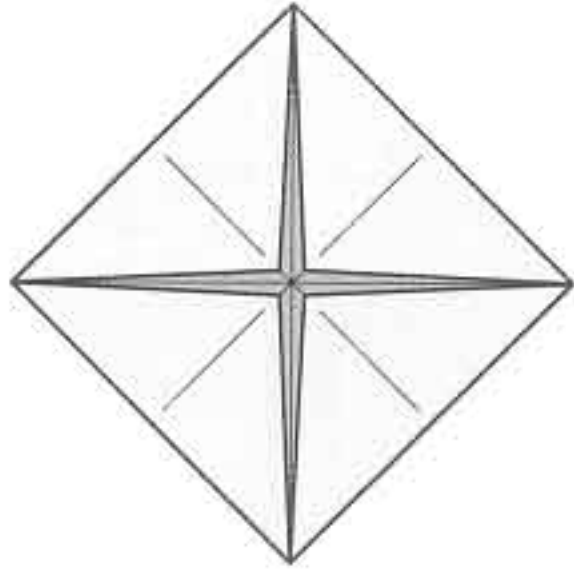

4 Turn over the model.

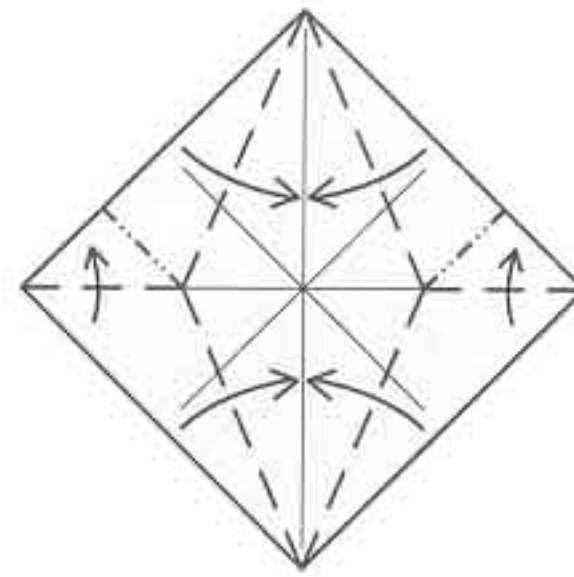
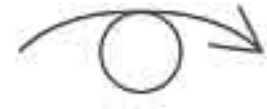

5 Fold a rabbit ear from the right and left corners. Be careful with the loose layers behind.

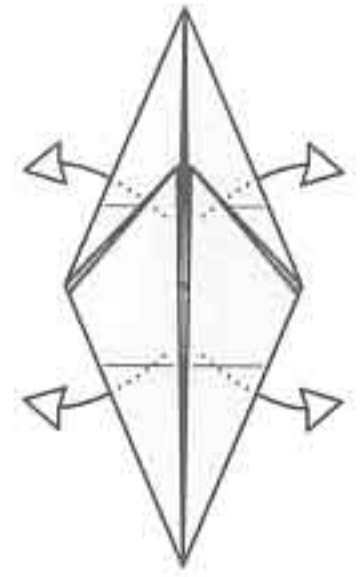

6 Pull out the loose paper from behind.

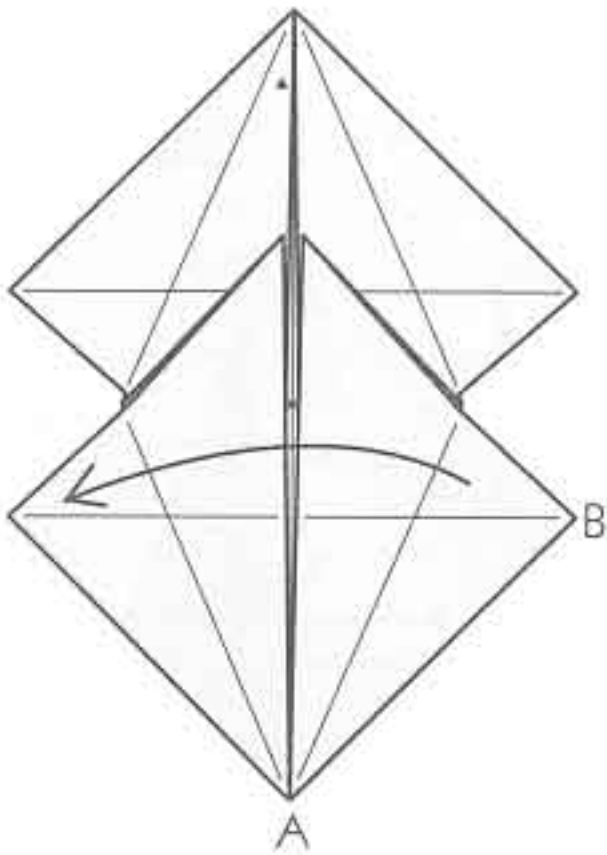

7 Fold flap B to the left.

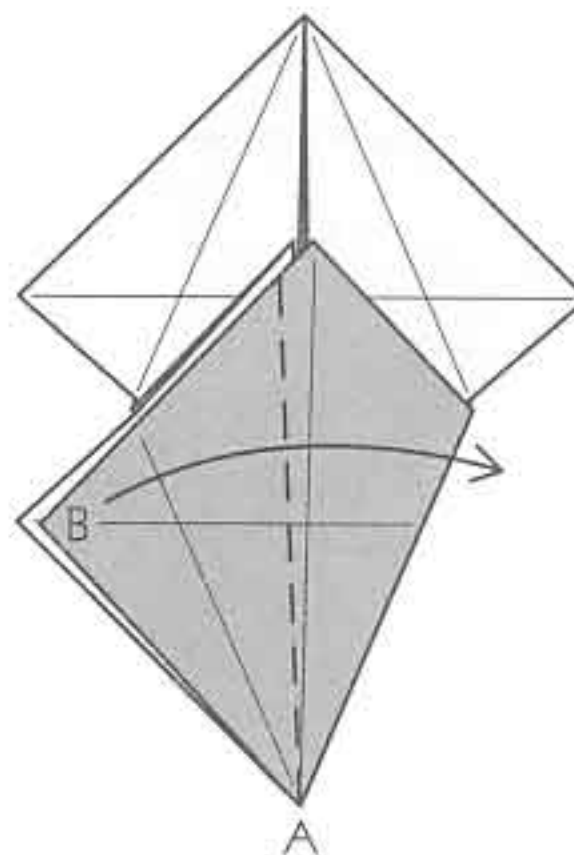

8 Fold flap B back to the right. Note that the crease doesn't hit the corner at the top.

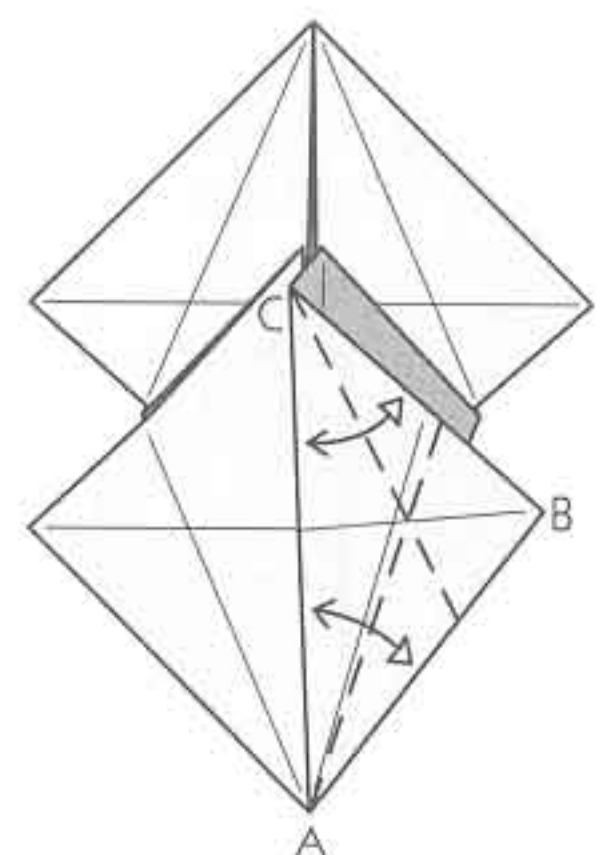

9 Fold edge AB to edge AC, crease, and unfold. (Note that this fold is not the same as the one that's already there.) Fold edge BC to edge AC, crease, and unfold.

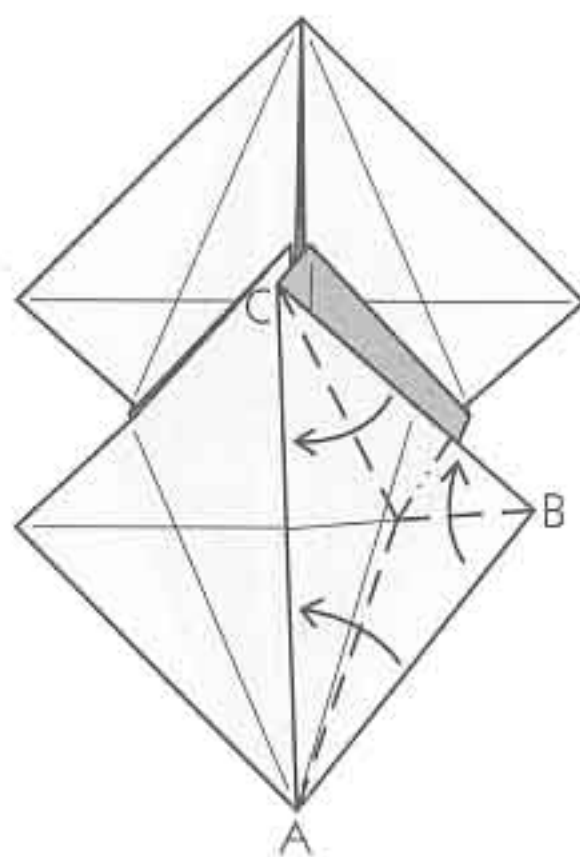

10 Use the crease you just made to make a rabbit ear of corner B.

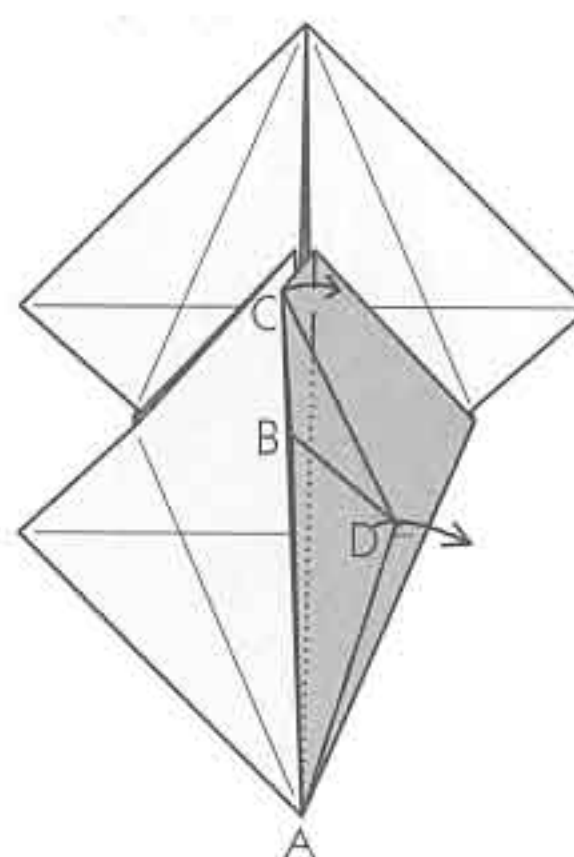

11 Slide corner D over to the right (the crease already exists). Flatten the model.

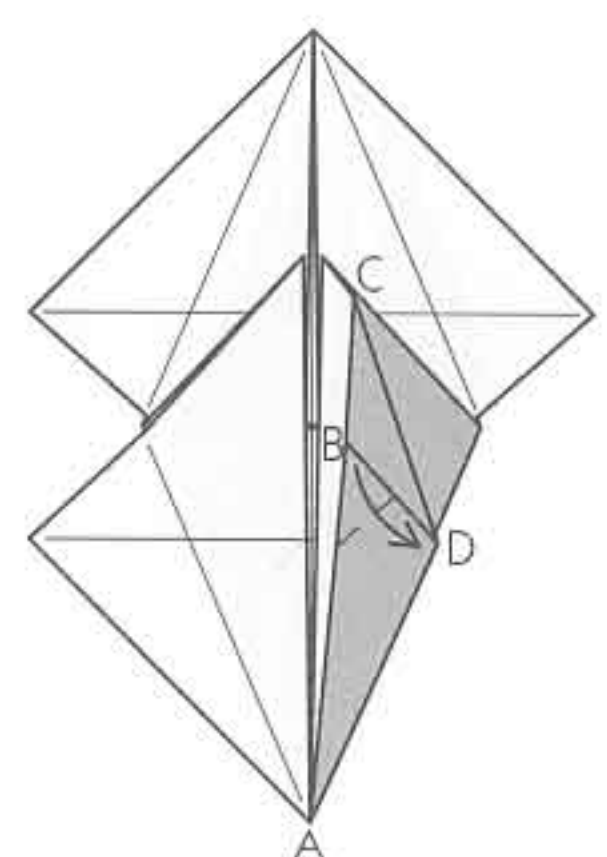

12 Fold corner B down to corner D.

American meadow

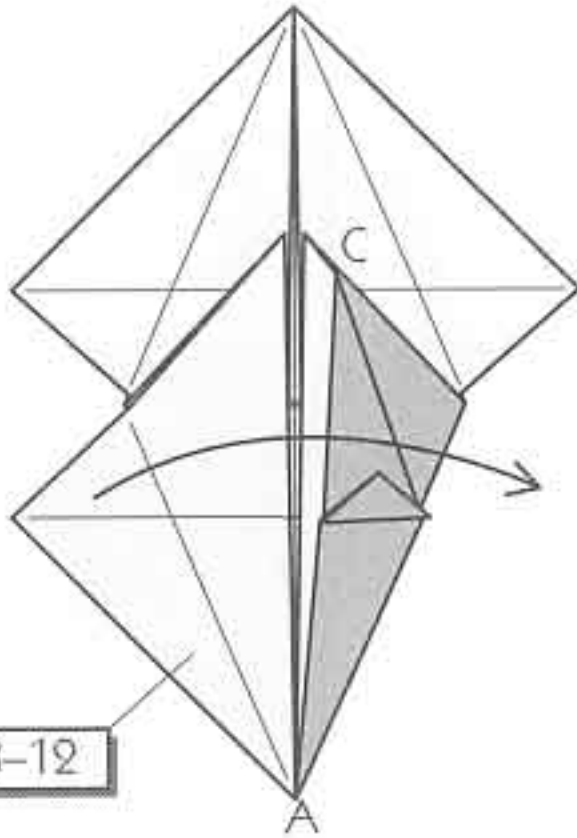

8-12

13 Repeat steps 8-12 on the left flap.

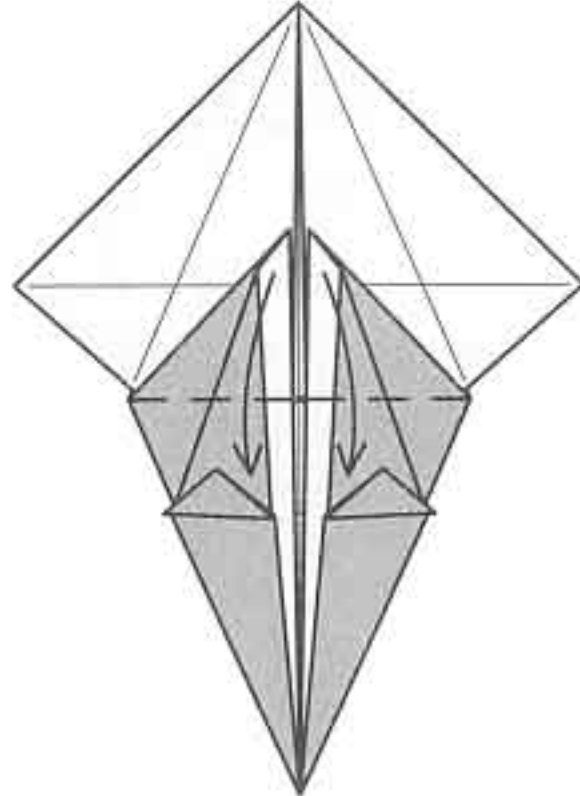

14 Fold two corners as far downward as possible.

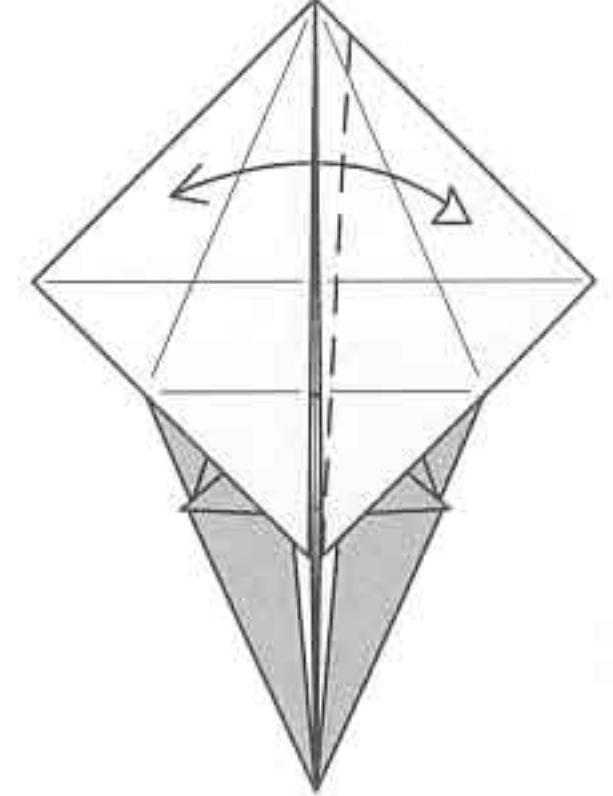

15 Fold the right corner to the left at the same angle as you did in step 8, crease, and unfold.

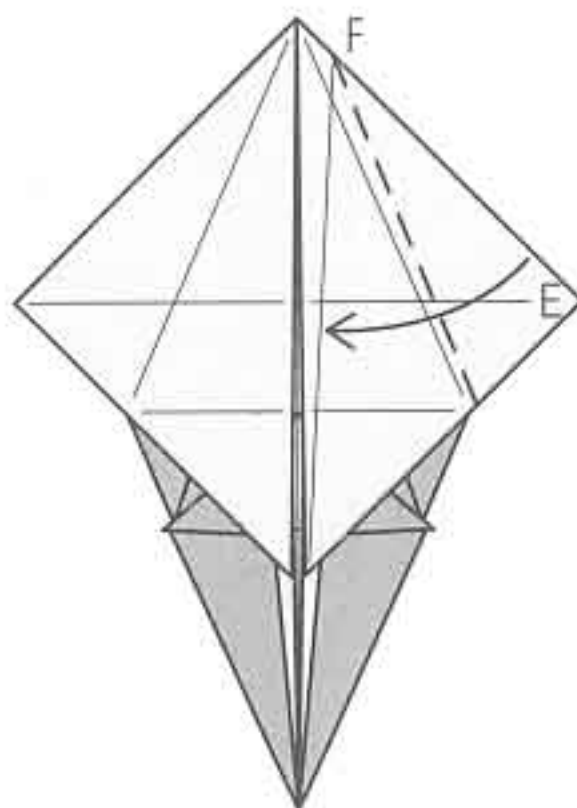

16 Fold edge EF in to lie along the crease you just made.

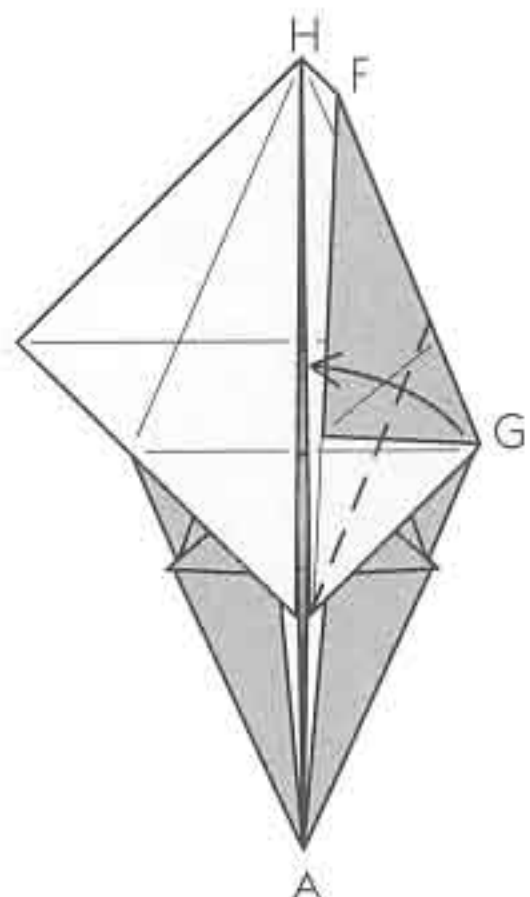

17 Fold corner G in to lie along the center line (line AH).

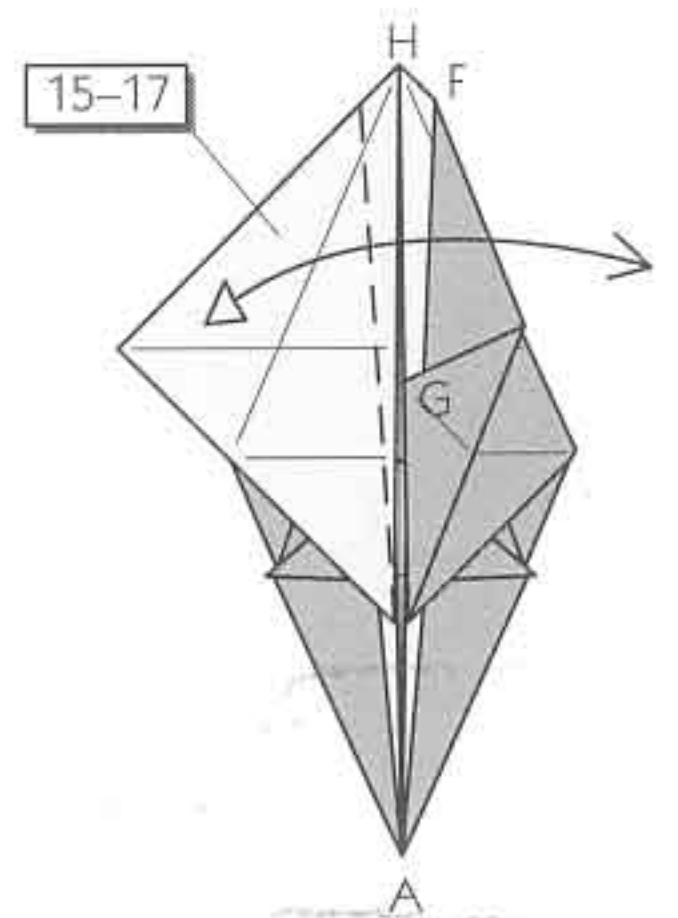

18 Repeat steps 15-17 on the left.

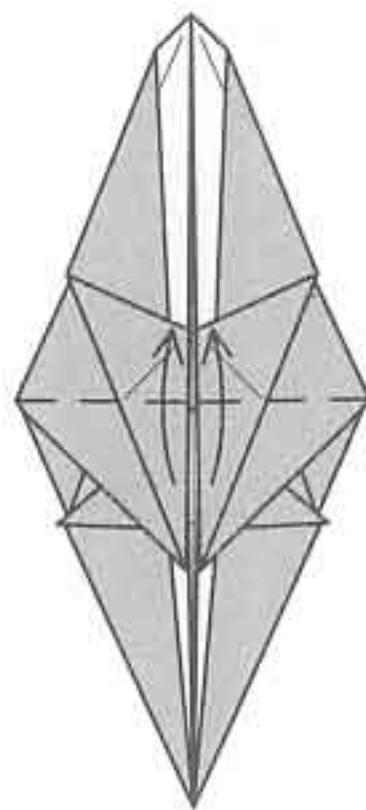

19 Fold the two points back up.

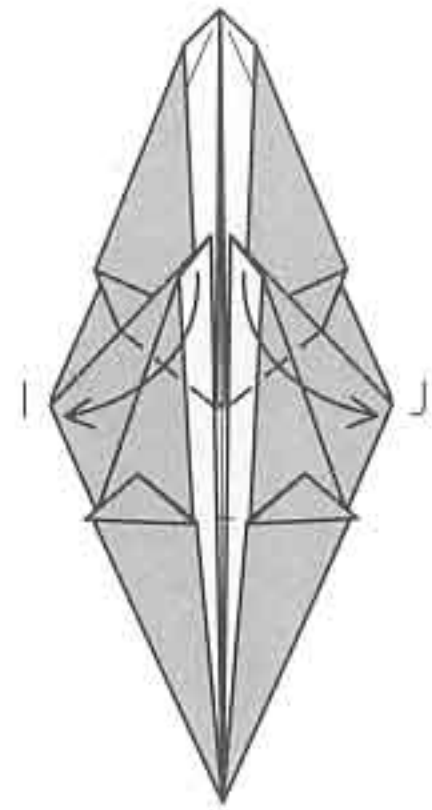

20 Fold each point to the outside. Note that both points wind up below corners I and J.

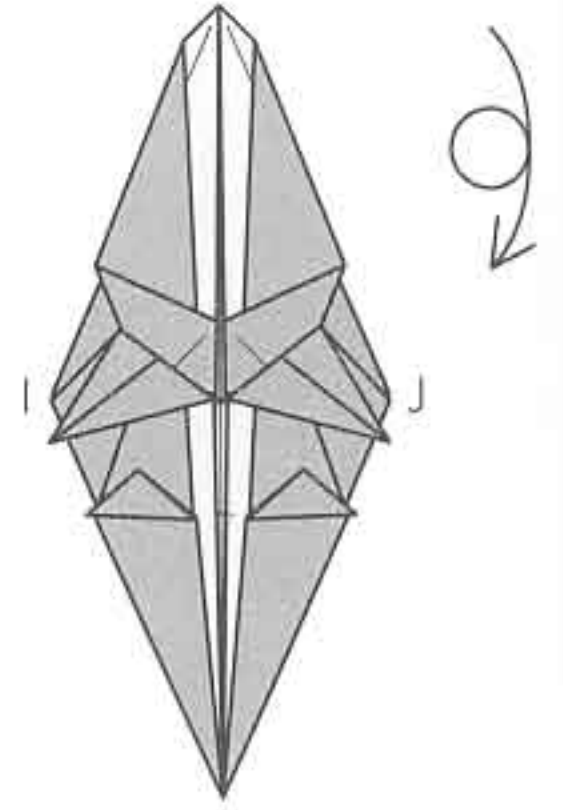

21 Turn the model over from top to bottom.

skunk

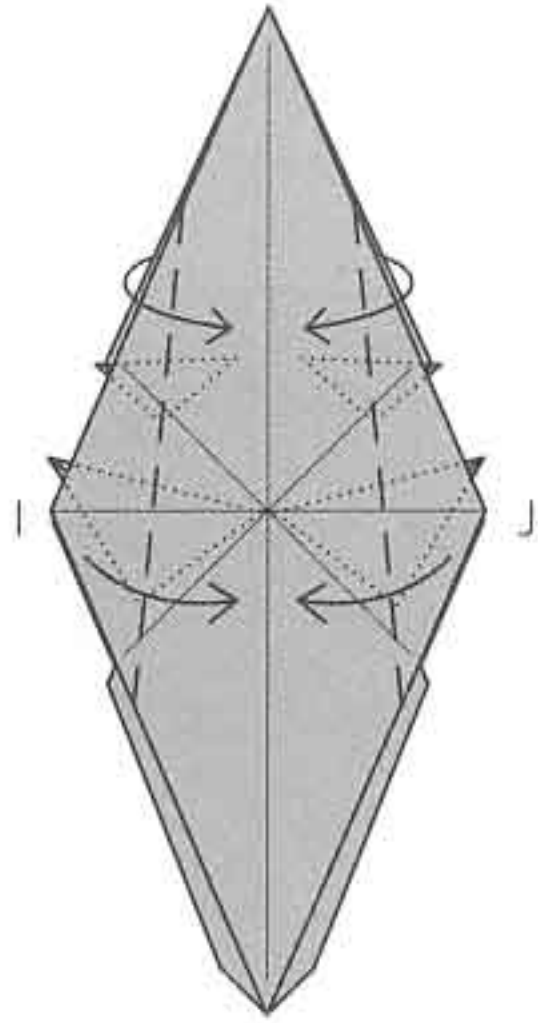

22 Fold the left and right edges in. At the top, you are folding a double layer of paper.

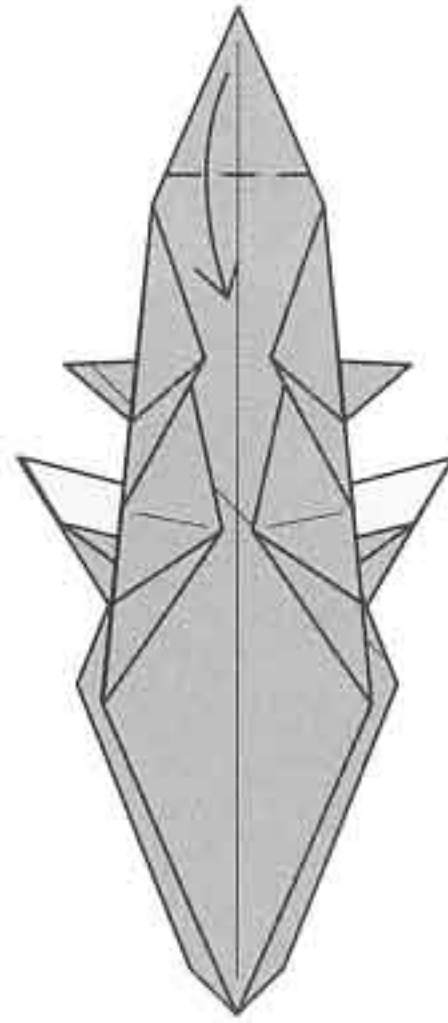

23 Fold down the top point.

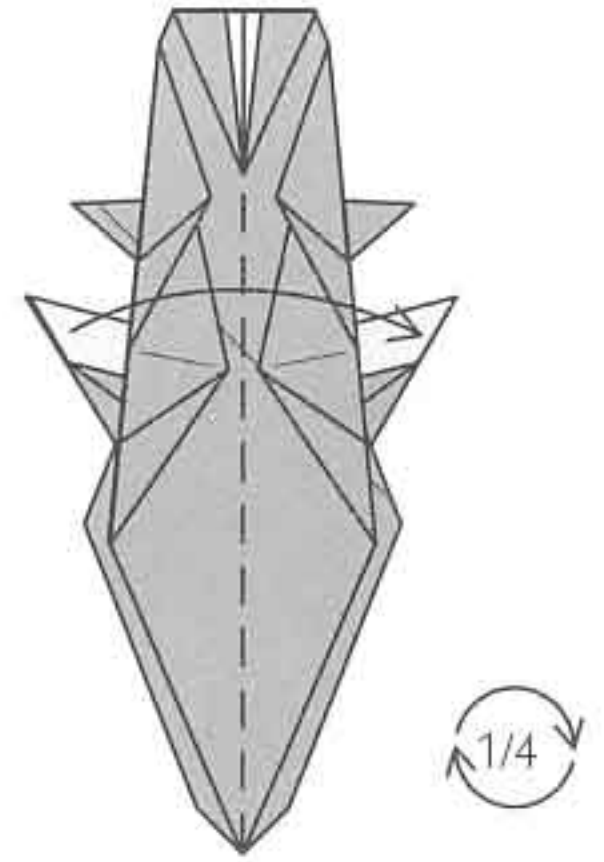

24 Fold the model in half. Rotate 1/4 turn clockwise.

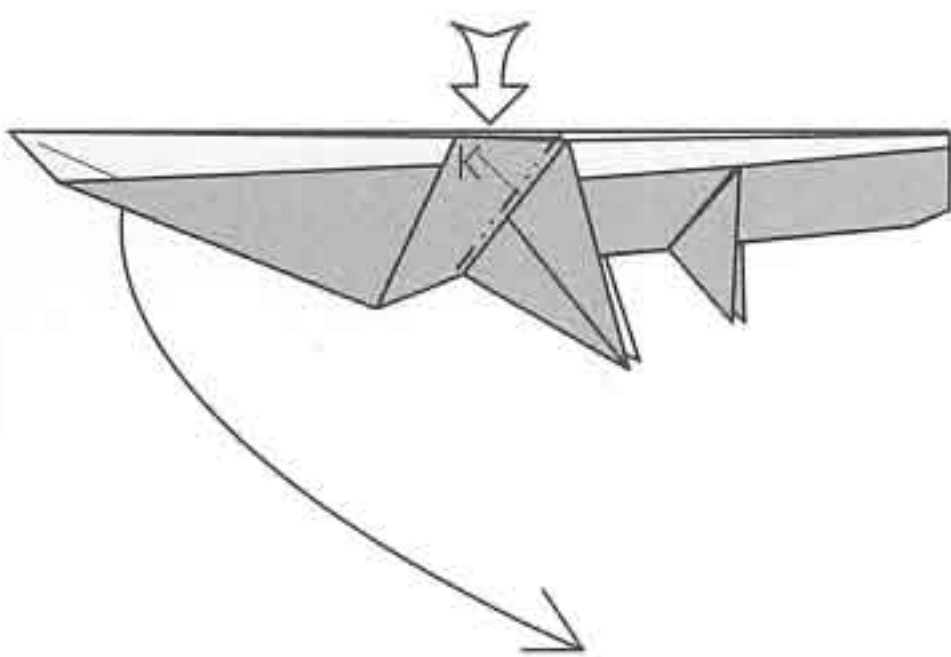

25 Reverse-fold the tail down. Note that corner K (and the corresponding corner behind) goes inside the reverse fold.

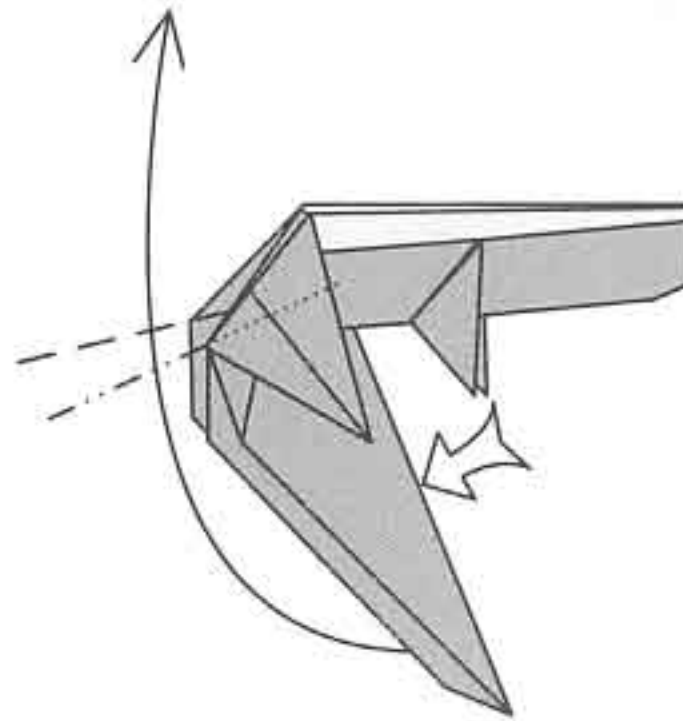

26 Reverse-fold the tail back up.

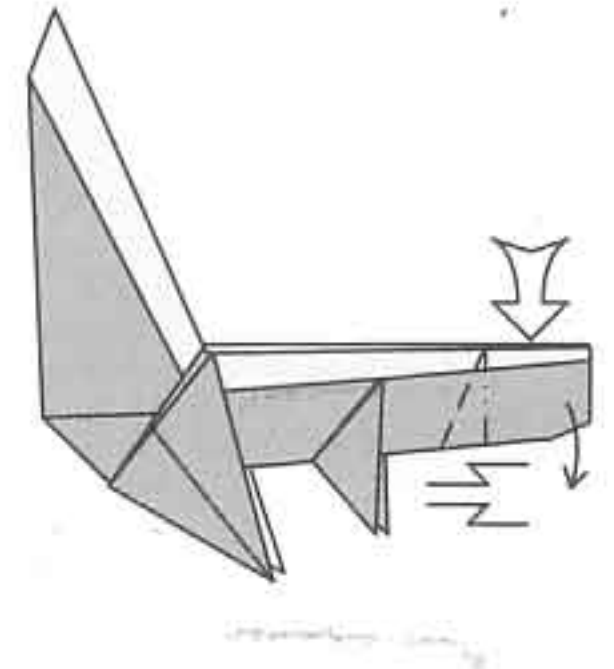

27 Crimp the head downward.

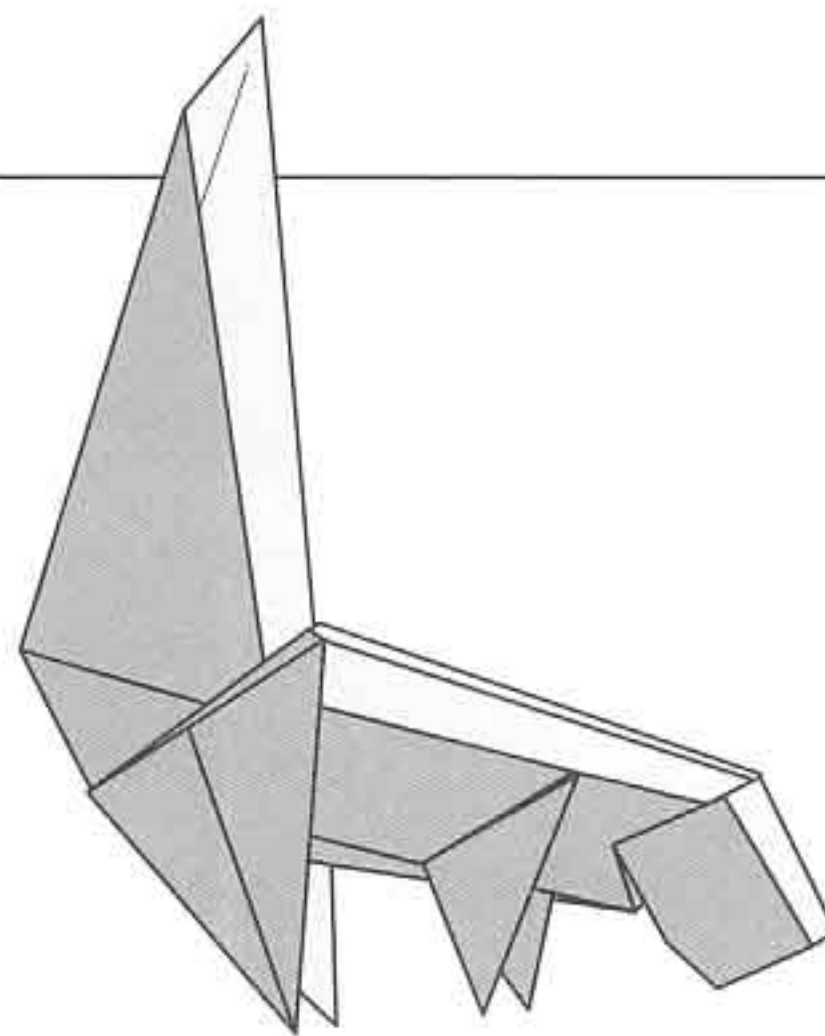

Finished Skunk.

◆ Swiss alp ◆

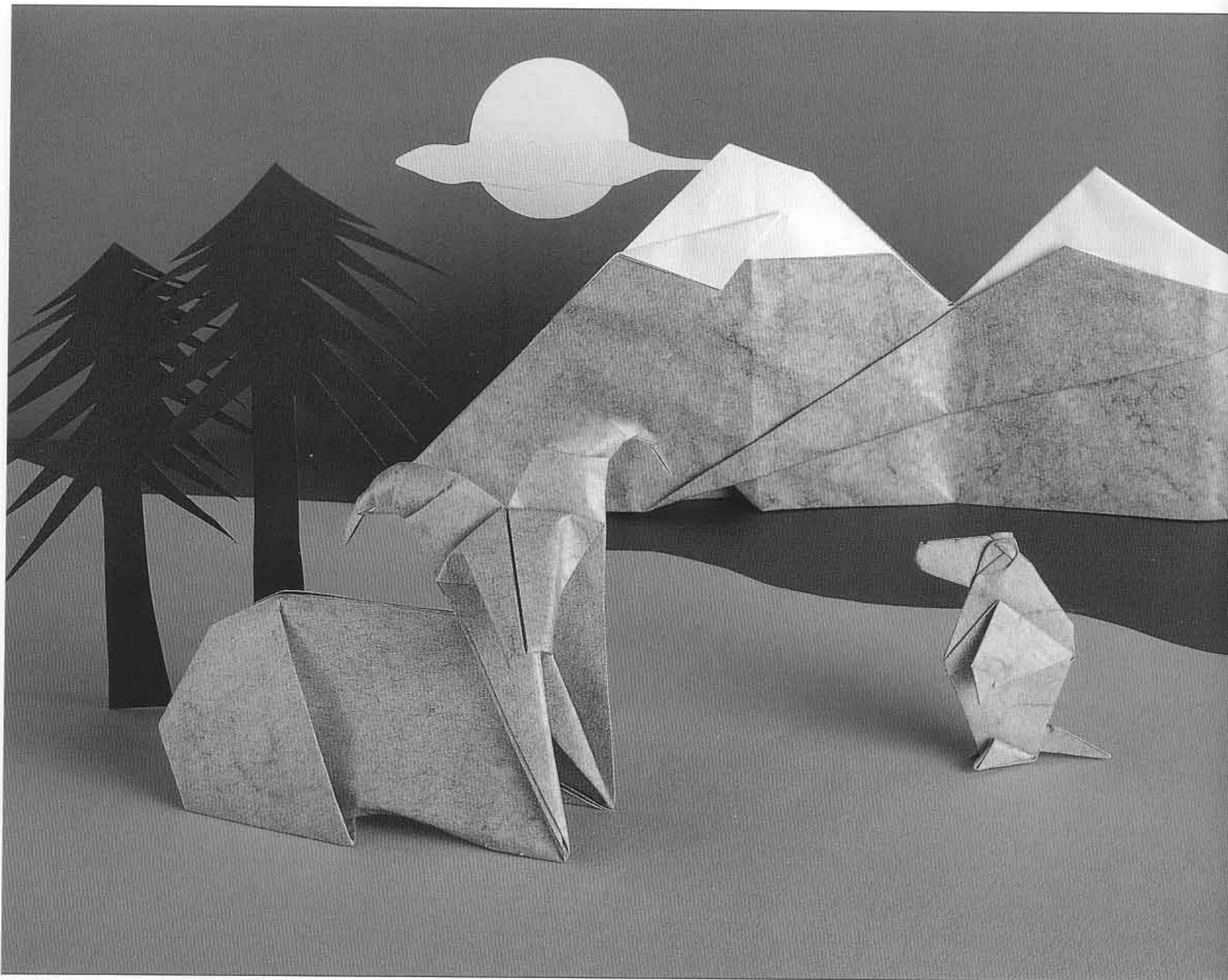

For this project, you will fold the following models:

Name	Page	Rating	Paper requirements
Mountain Range	37	Easy	24 in (60 cm) square of brown paper, white on one side
Marmot	39	Low Intermediate	6 in (15 cm) square of brown paper
Ibex	42	Low Intermediate	12 in (30 cm) square of tan paper, white on one side

◆ mountain range ◆

designed by Gloria Farison

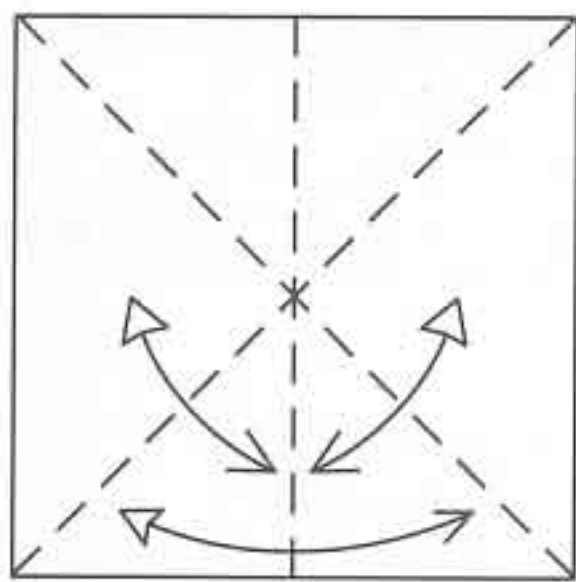
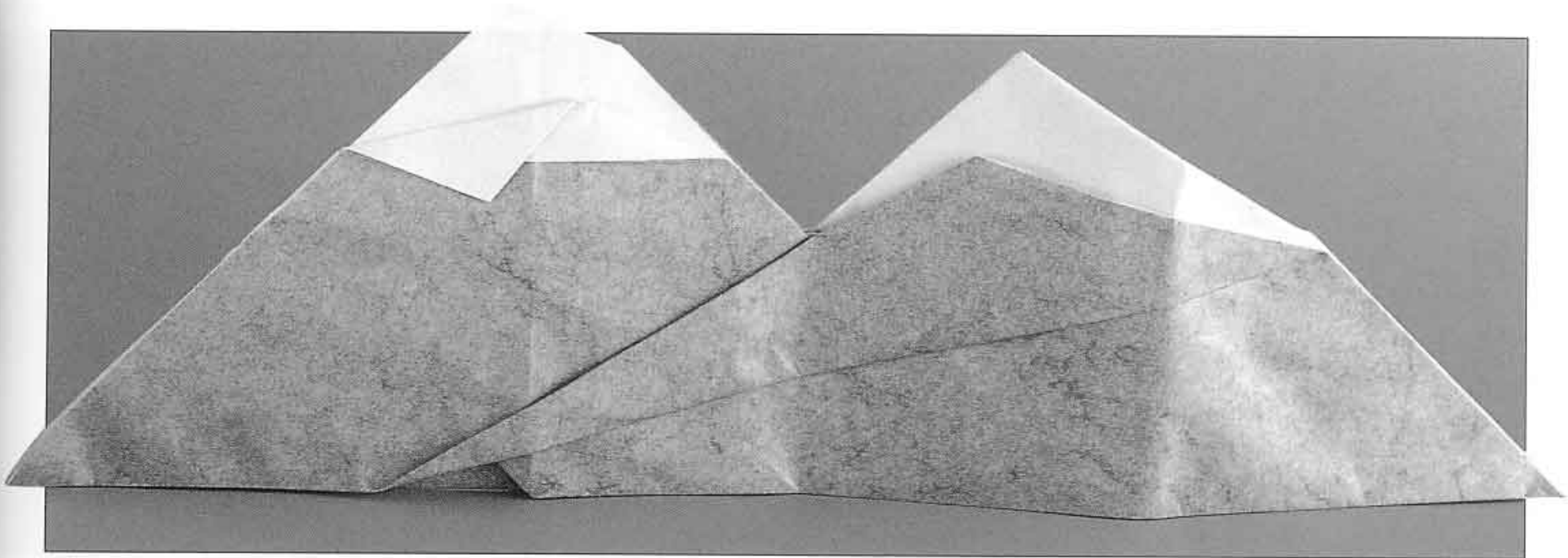

1 Begin with the white side up. Fold and unfold the paper vertically and along the diagonals.

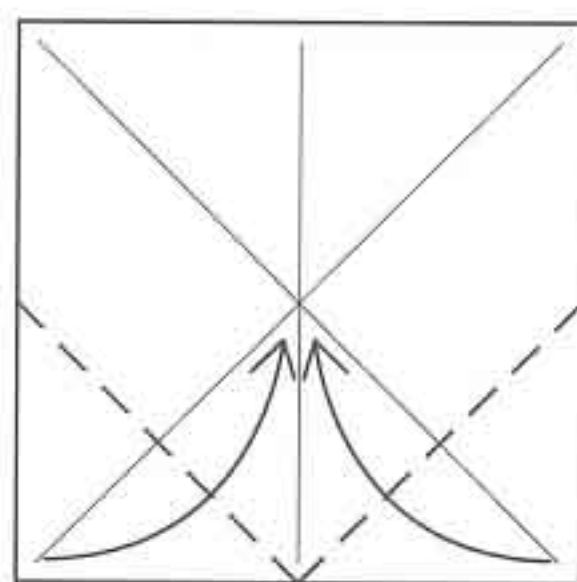

2 Fold the two bottom corners up to meet in the middle of the paper.

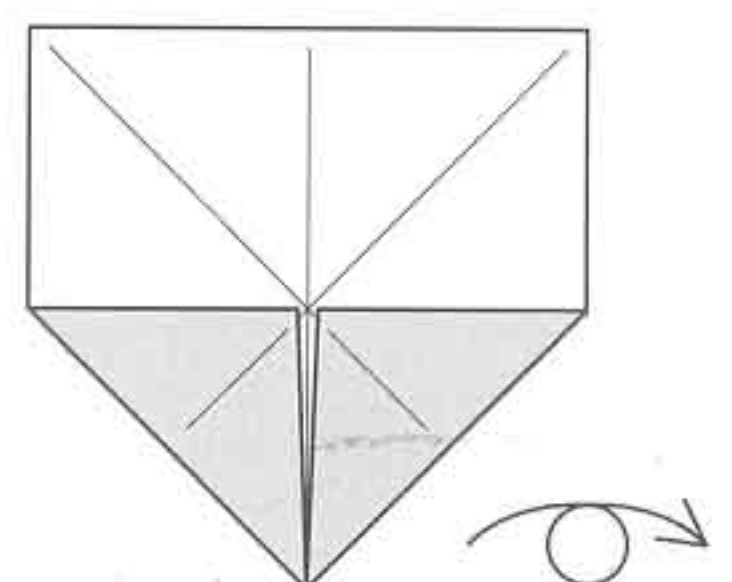

3 Turn the model over.

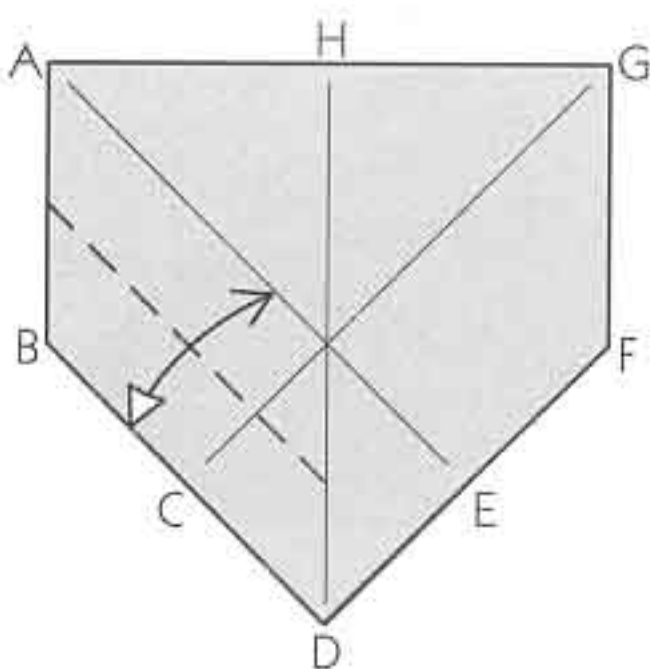

4 Fold edge BD up to lie along crease AE, making the crease sharp only from side AB to where it hits crease HD. Unfold.

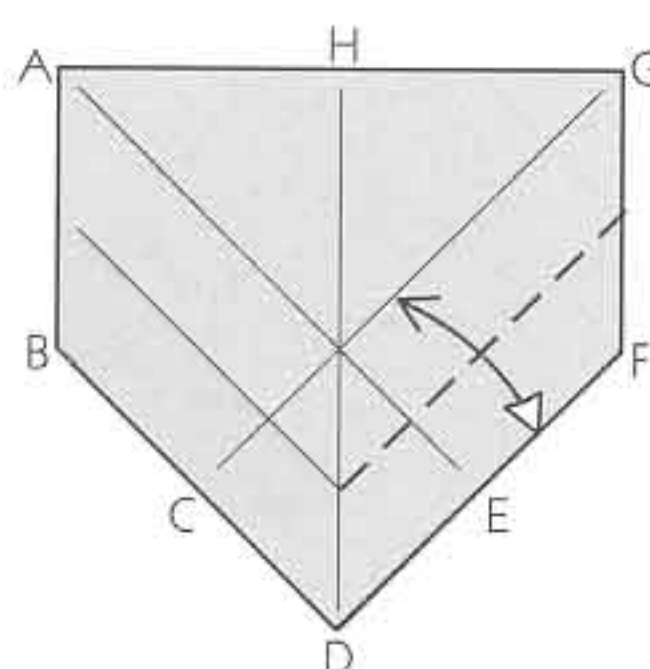

5 Repeat on the right with edge DF.

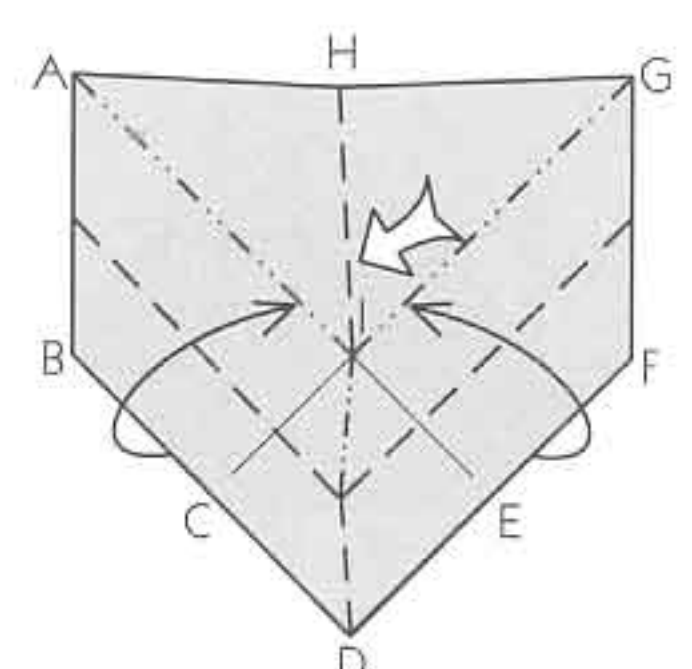

6 Bring edges BD and DF up and toward each other. At the same time, push down on crease HI. Look ahead to step 7 to see the shape you are trying to make.

Swiss alp

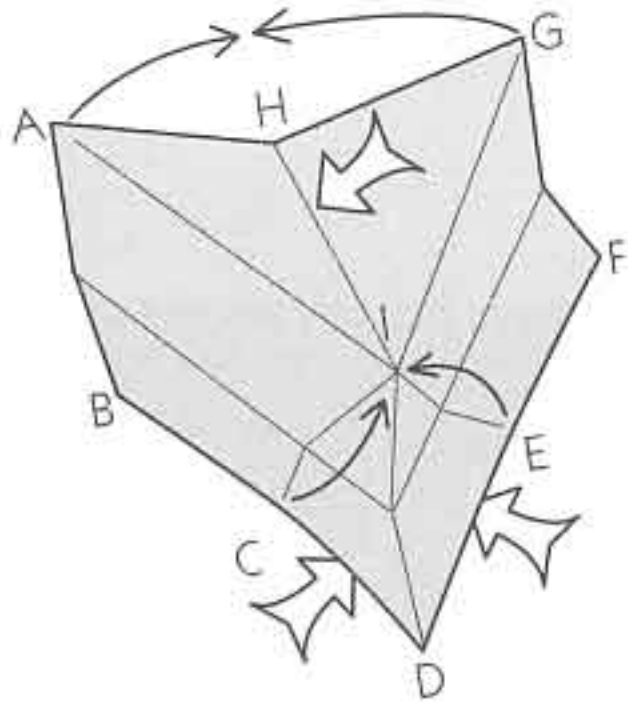

7 Bring C and E to I and bring corners A and G together.

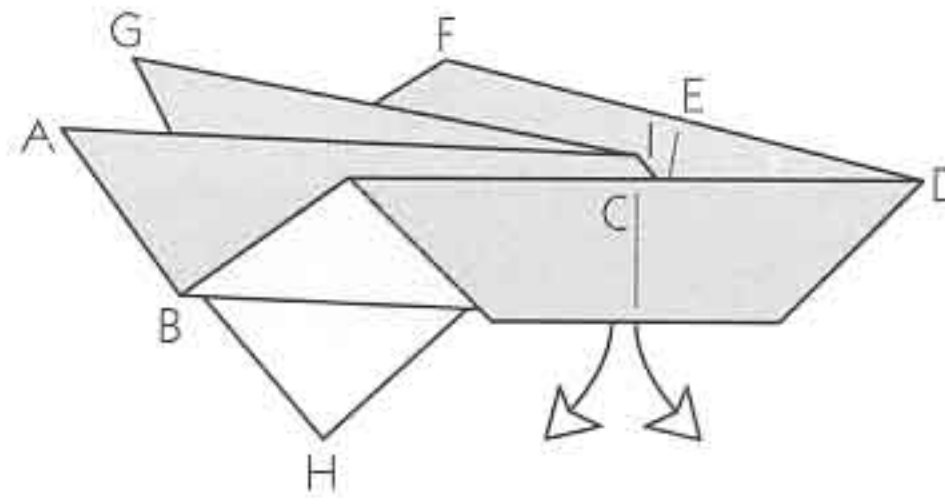

8 Flatten completely and pull out the two loose corners from the bottom.

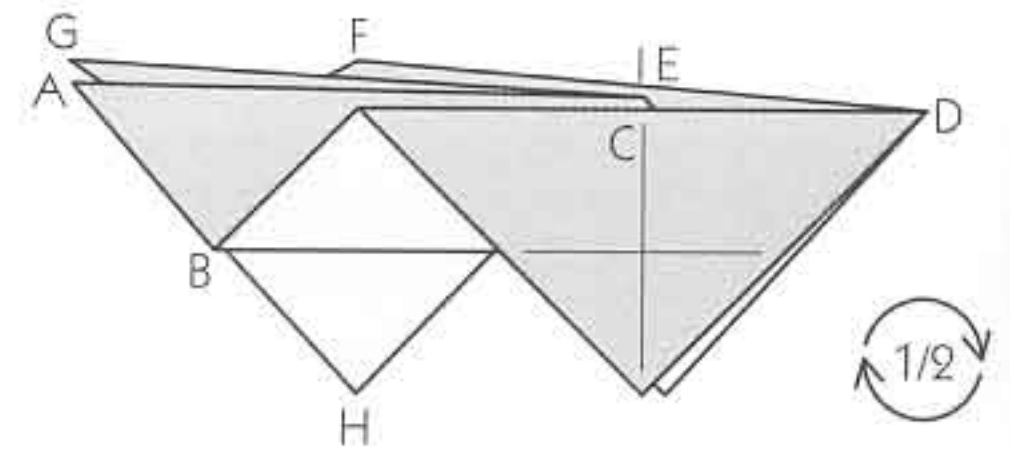

9 Rotate the model 1/2 turn.

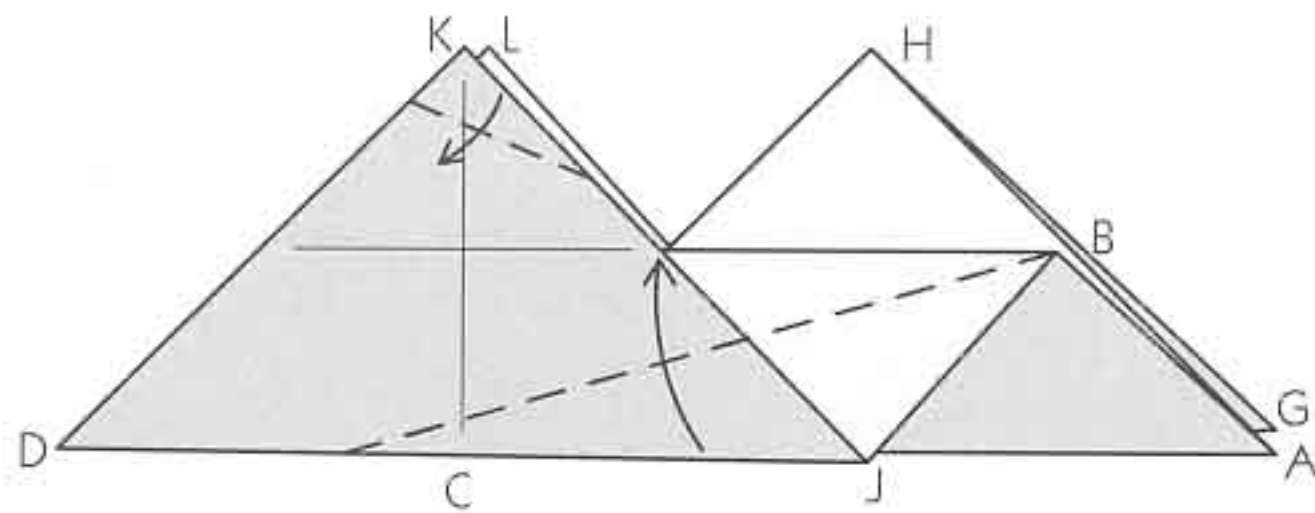

10 Fold down a portion of corner K (the exact amount isn't critical). Fold part of edge DJ upward so that the edge touches the saddle between the two peaks.

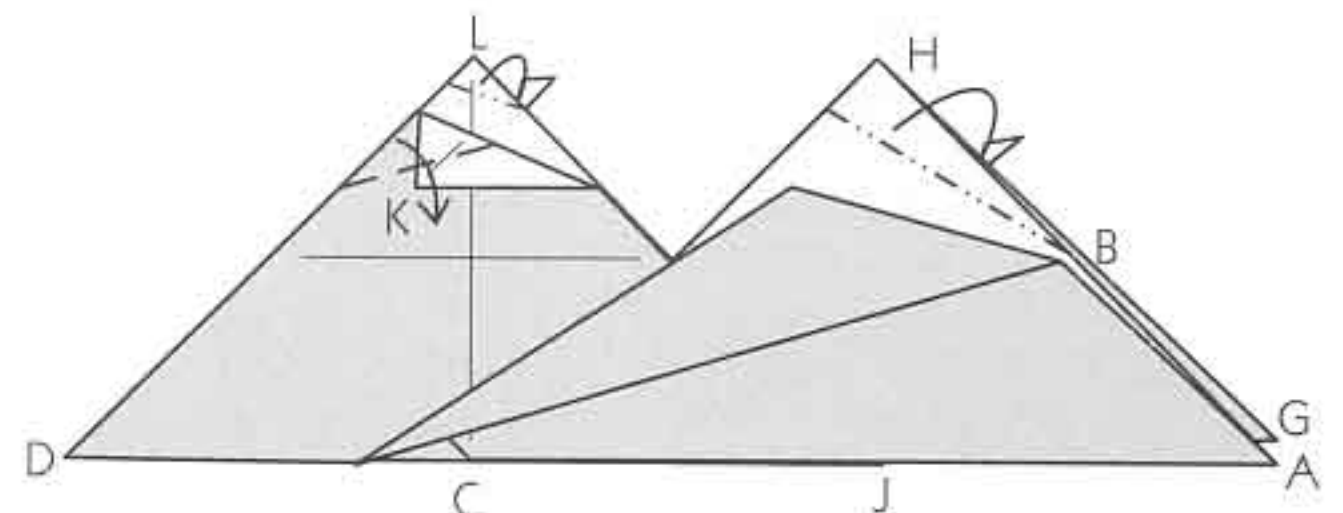

11 Fold corners L and H behind asymmetrically. Fold a portion of the edge down over corner K.

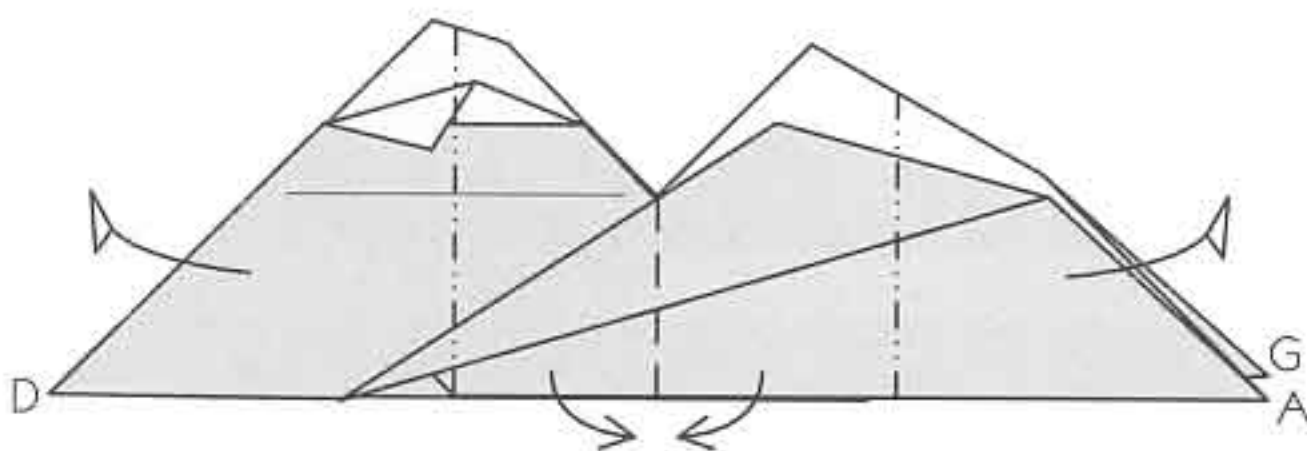

12 If you slightly pleat the model in a zig-zag as shown, the range will stand by itself. In addition, you can make more than one and tuck corners A and G into the pockets in corner D to make a longer mountain range.

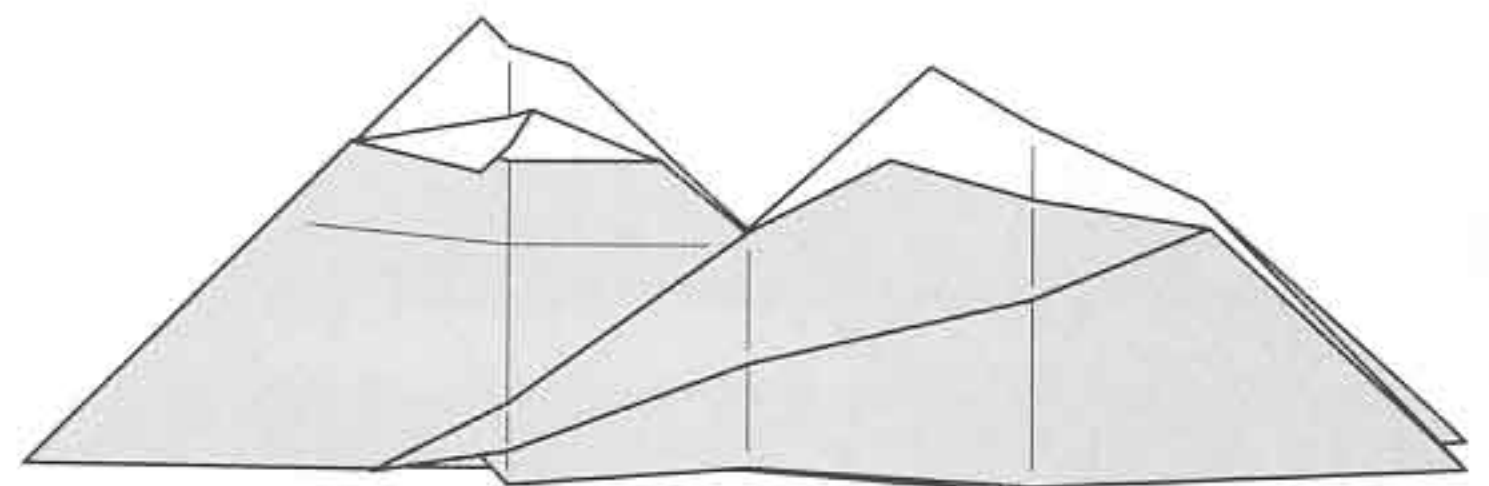

Finished Mountain Range.

◆ marmot ◆

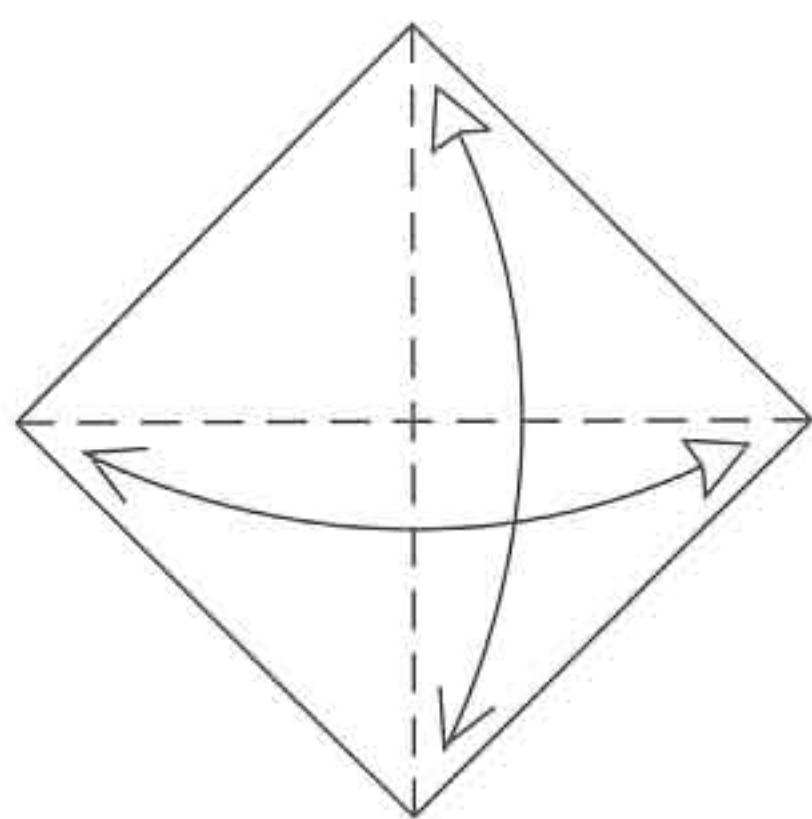
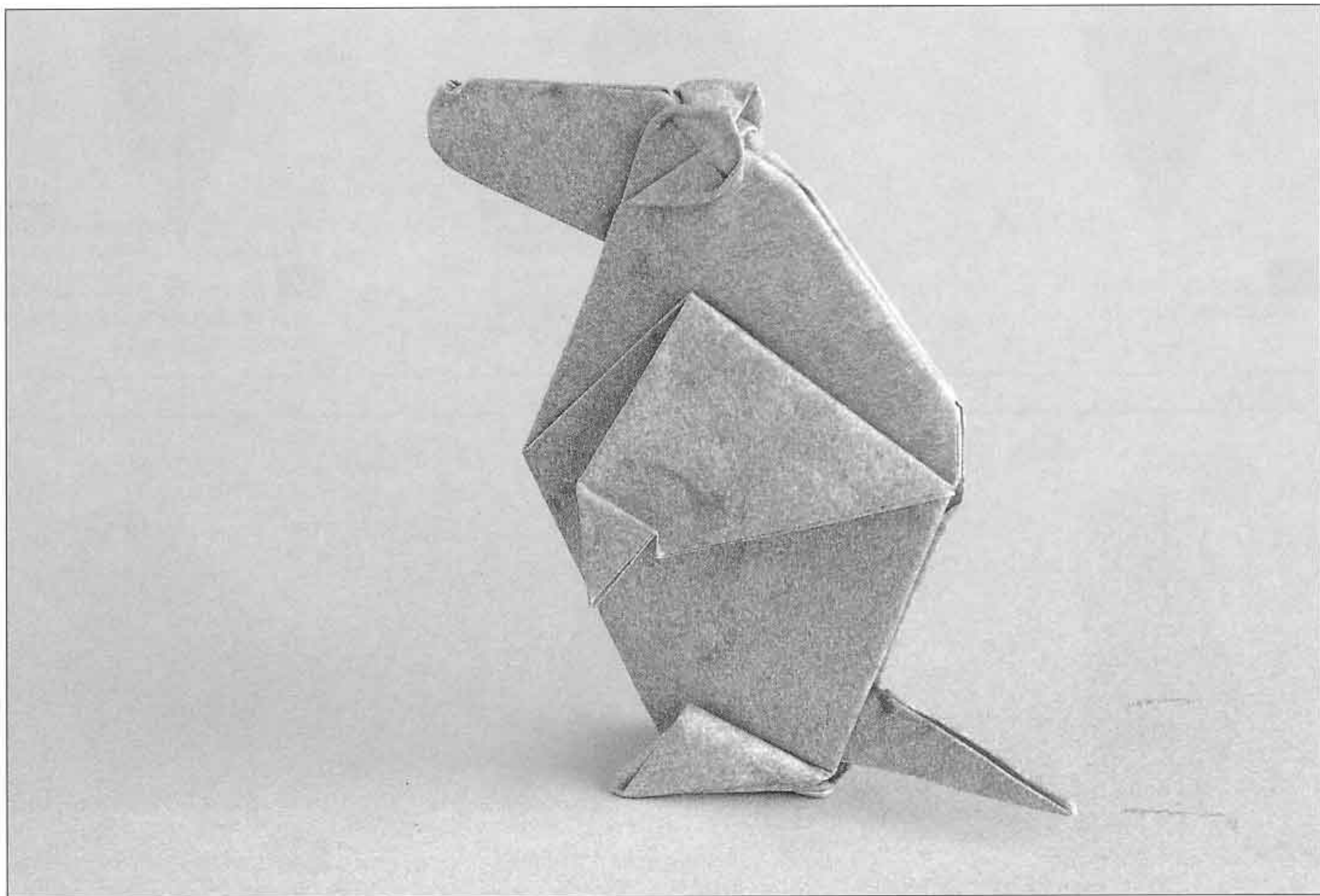

1 Begin with the white side up. Fold the paper in half along the diagonals and unfold.

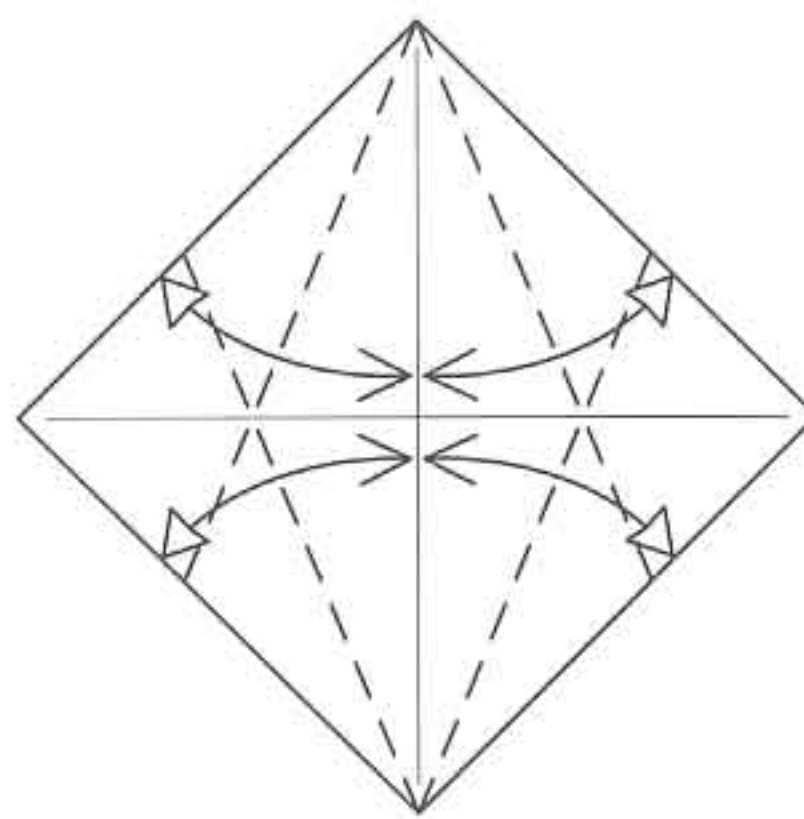

2 Fold in each of the four edges to lie along the center line and unfold.

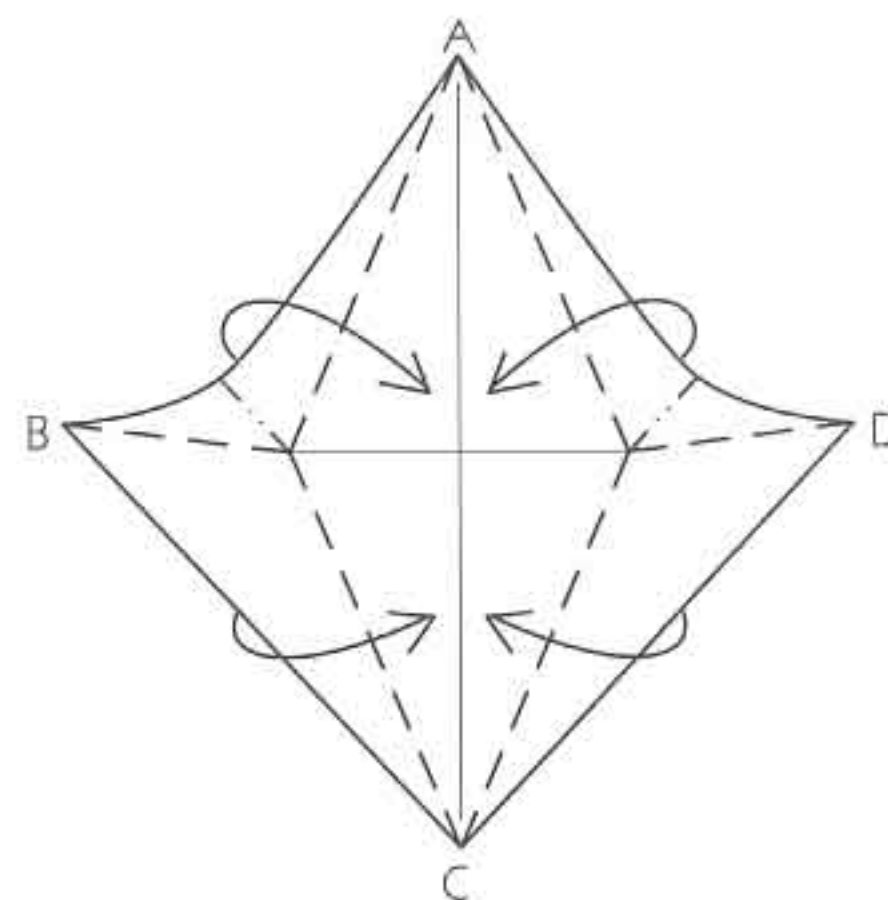

3 Bring all four edges to the center line at once.

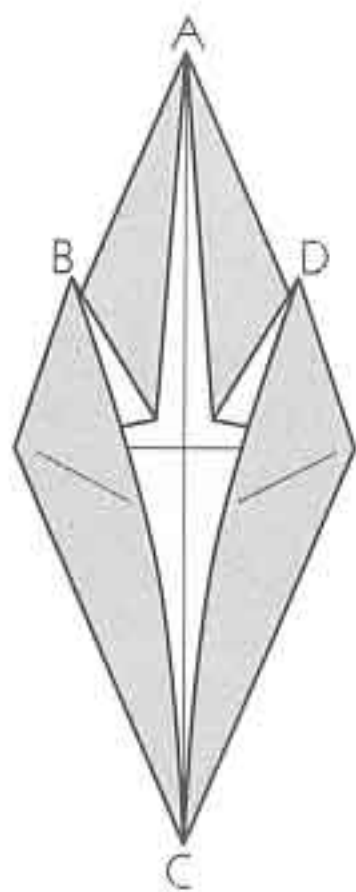

4 Bring corners B and D upward and flatten the model.

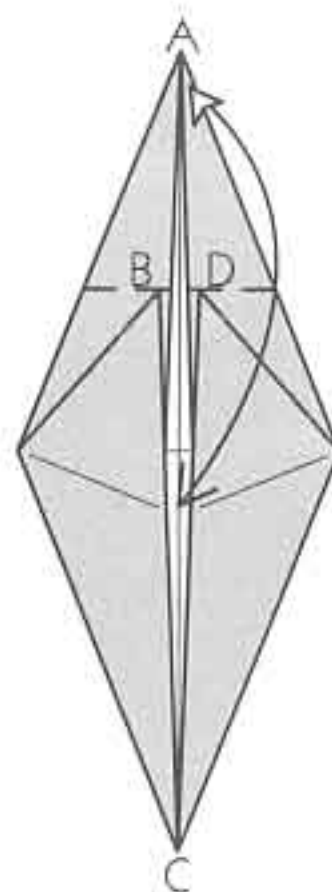

5 Fold point A down to the point where two creases hit the raw edges (the crease runs just under points B and D). Unfold.

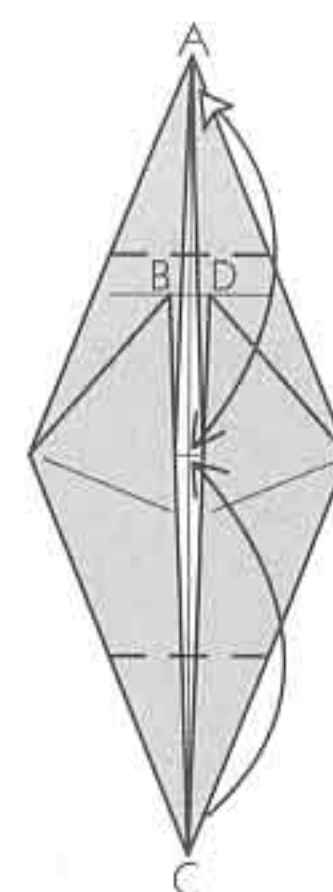

6 Fold points A and C to meet each other in the middle of the model; unfold point A.

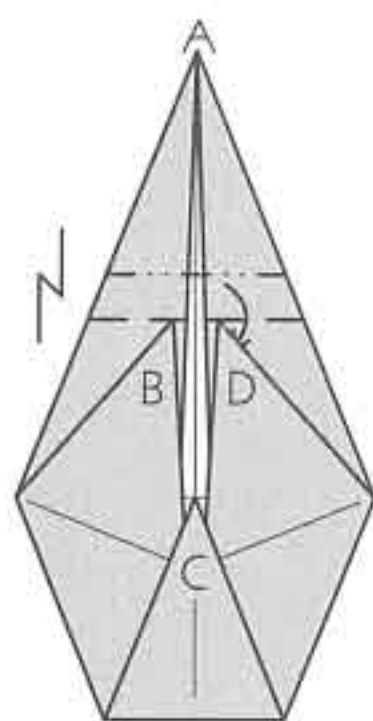

7 Pleat flap A downward behind flaps B and D, using the existing creases.

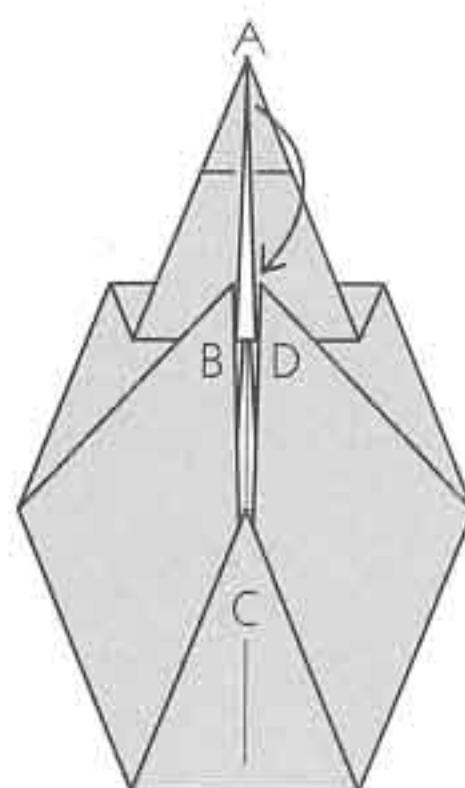

8 Fold down point A to meet corners B and D.

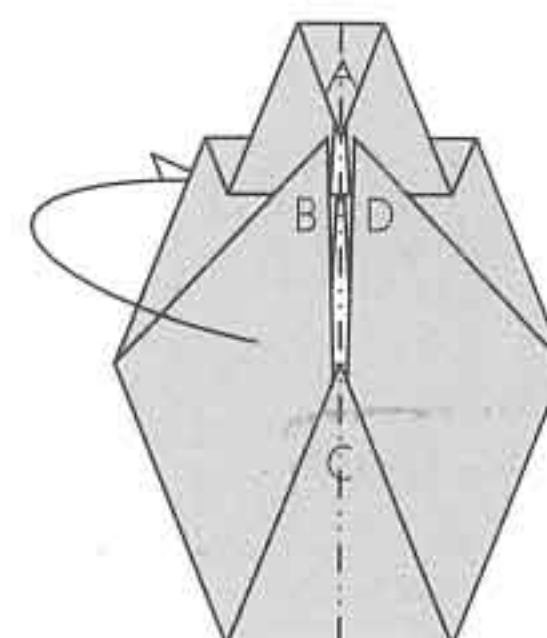

9 Mountain-fold the model in half.

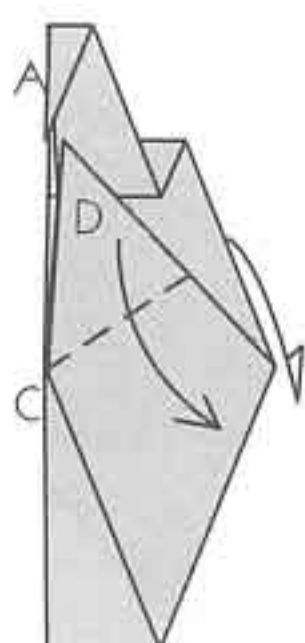

10 Fold corner D down in front. Repeat behind with corner B. There is no reference point for this crease.

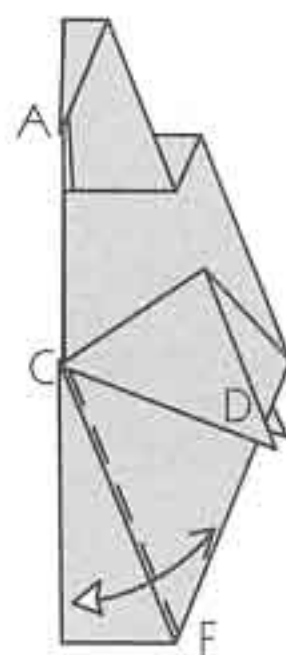

11 Fold the bottom along edge CF and unfold.

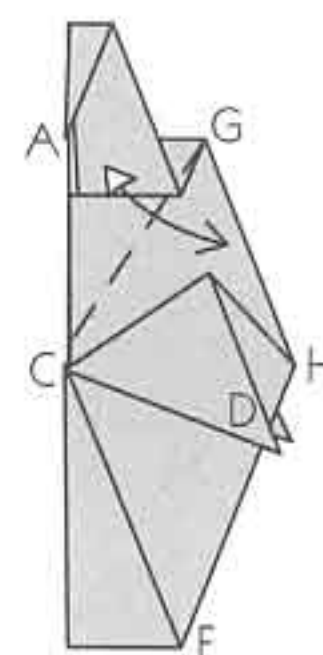

12 Fold the top down so that edge AG lies along edge GH; crease firmly and unfold.

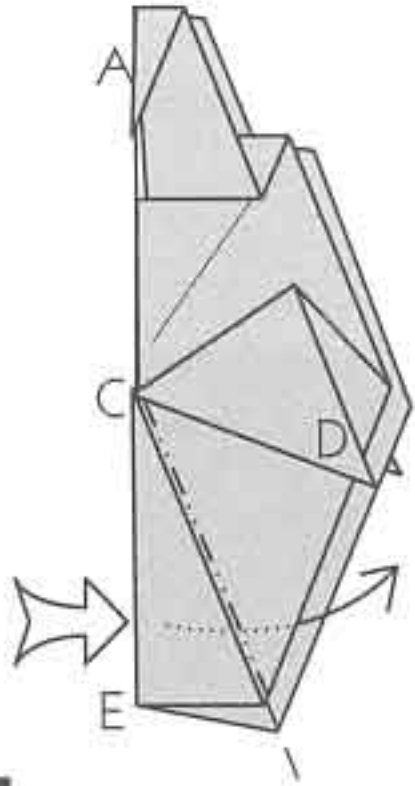

13 Reverse-fold edge CE to the right by pushing it between the layers of the body.

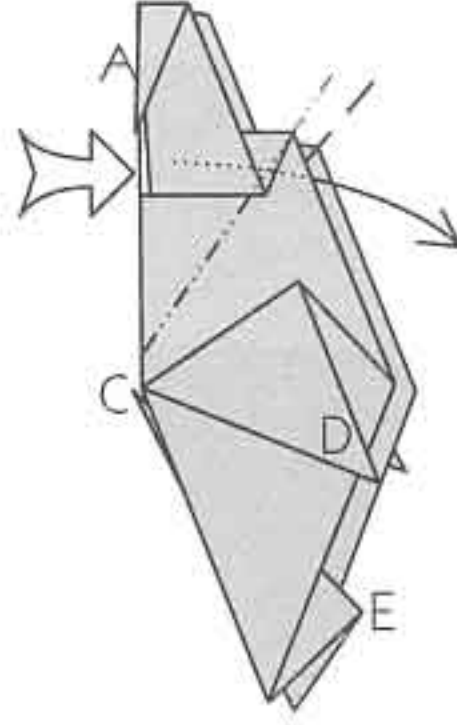

14 Reverse-fold the upper part of the model by pushing on edge CA so that it turns inside-out and goes between the layers of the body.

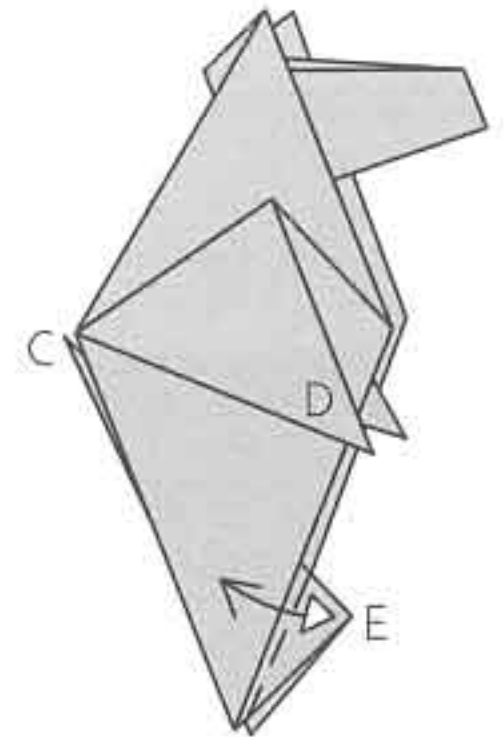

15 Fold and unfold.

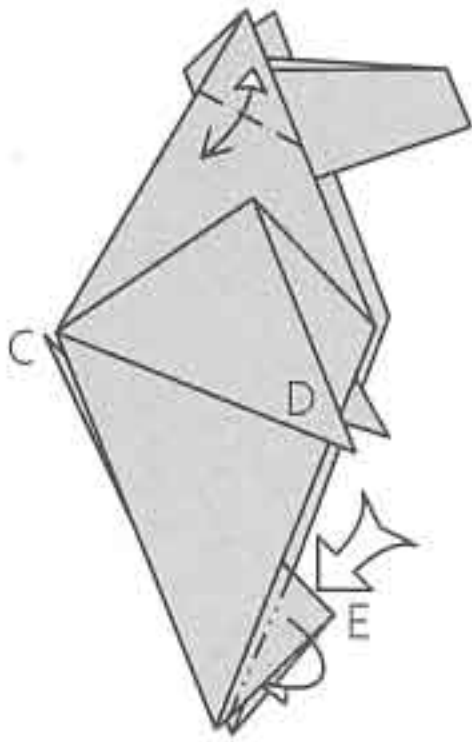

16 Reverse-fold corner E. Fold the ear down and unfold. Repeat behind on the other ear.

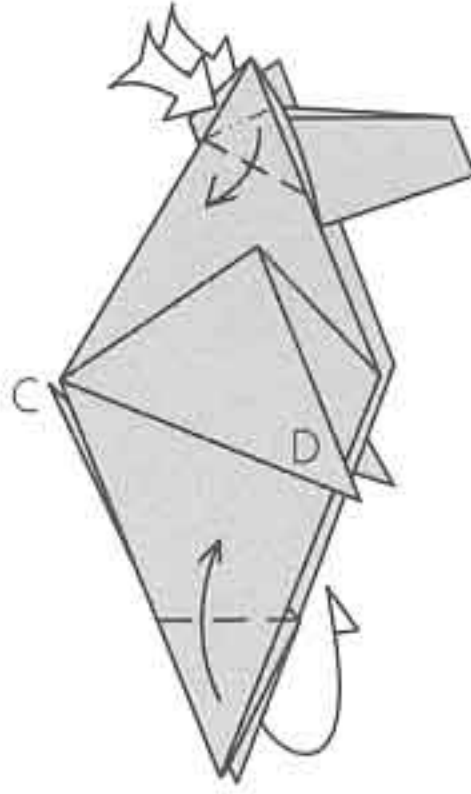

17 Squash-fold the ears. Fold one foot upward as far as possible on each side.

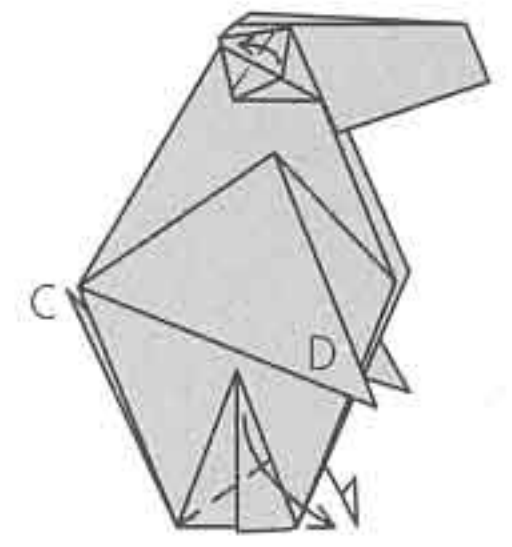

18 Valley-fold the feet down and to the right. Open up the ear by lifting the flap and rounding its edges. Repeat behind.

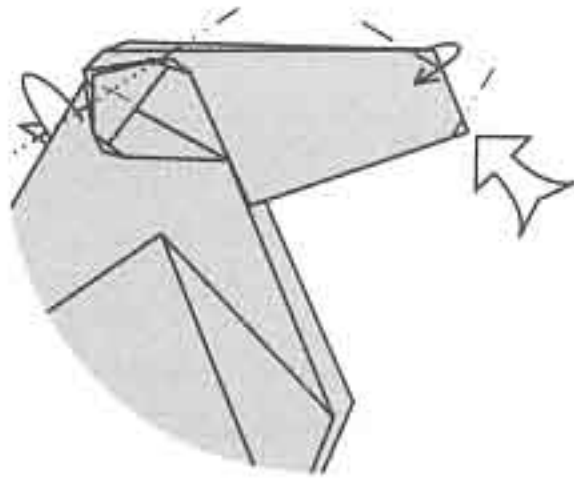

19 Enlarged view of head. Mountain-fold the corners behind the ears. Reverse-fold the bottom of the nose. Valley-fold one of the top corners of the nose; repeat behind.

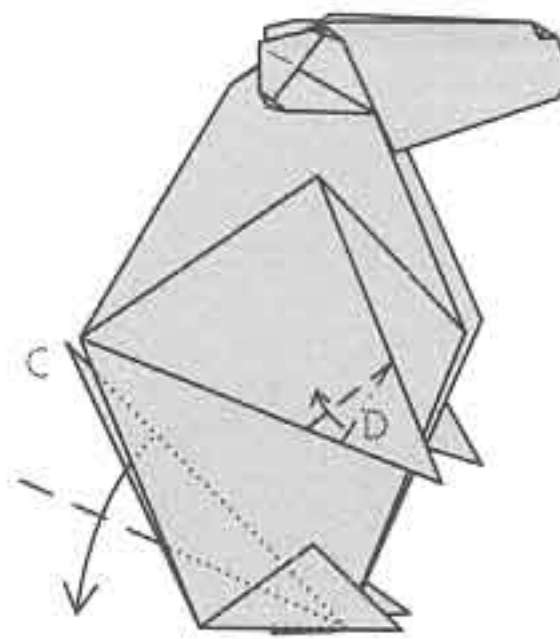

20 Valley-fold corner C down from inside the body. Pleat the paw (point D). Repeat behind.

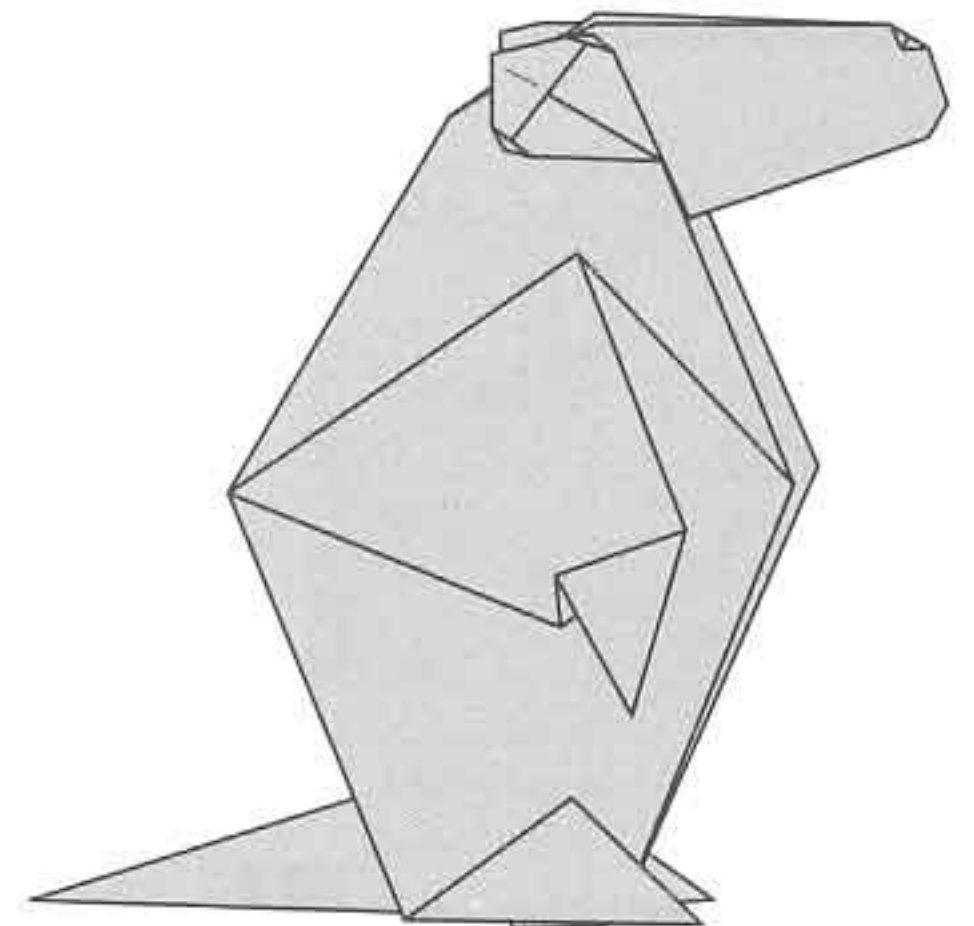

Finished Marmot.

◆ ibex ◆

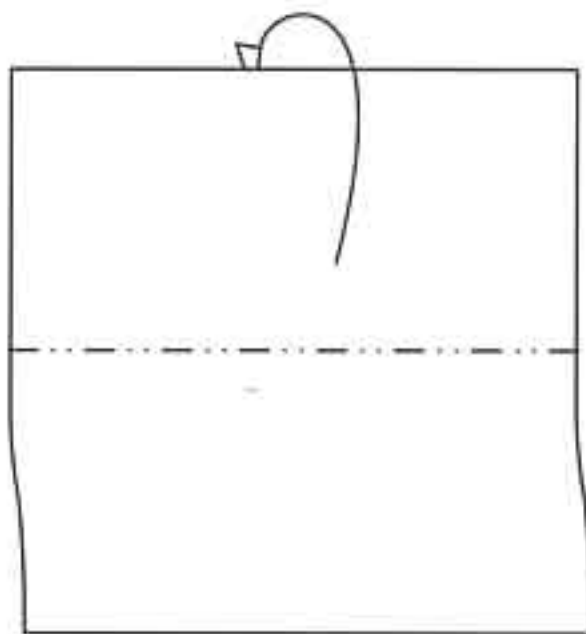
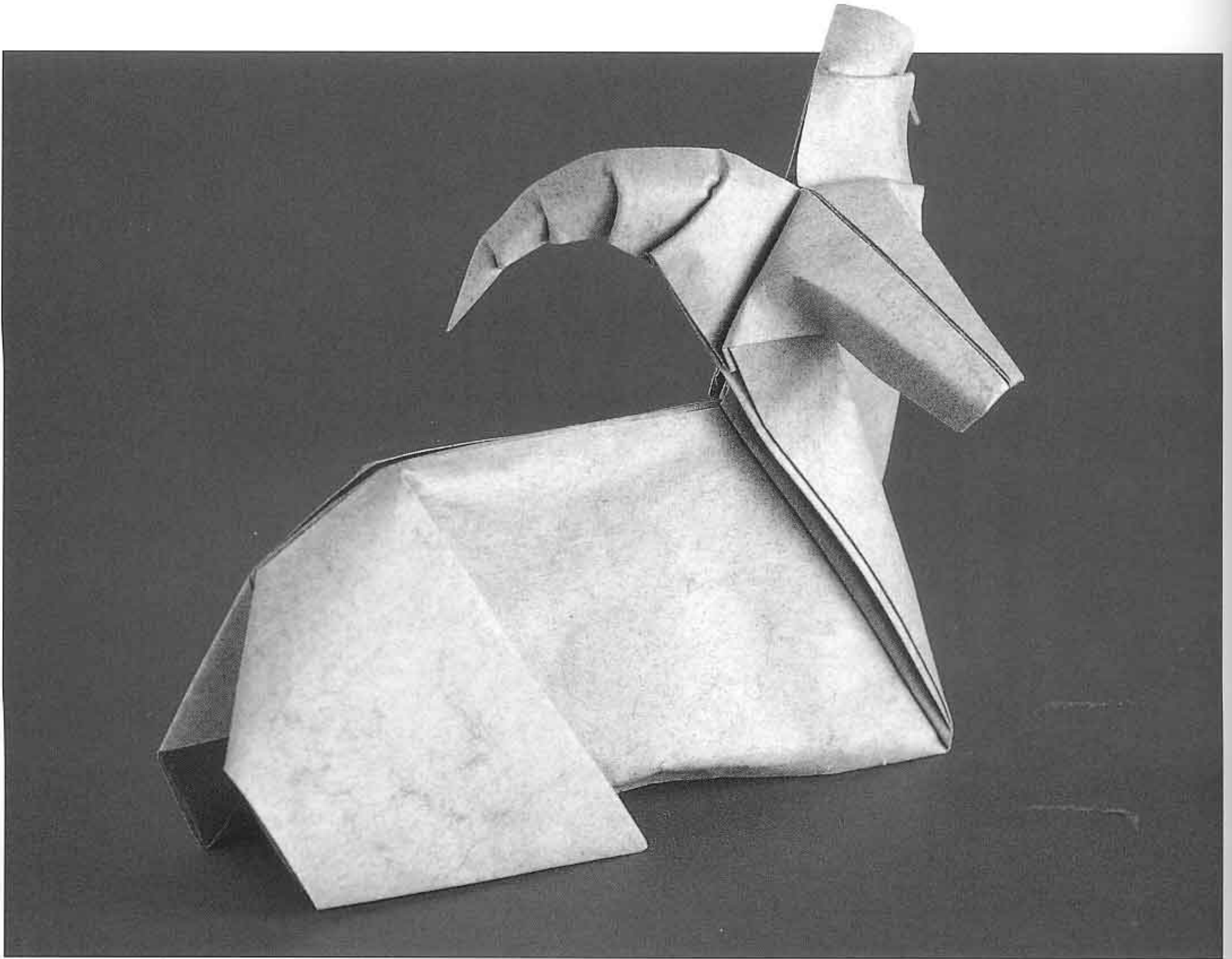

1 Begin with the white side up. Mountain-fold the top half of the paper behind.

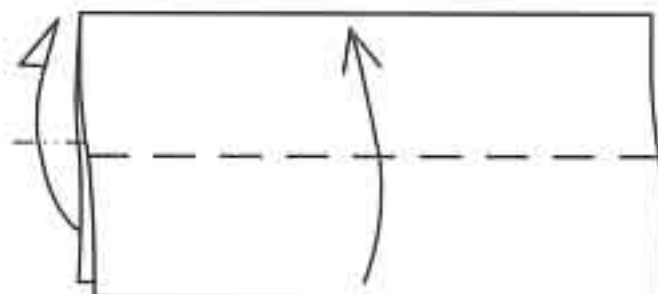

2 Fold one edge up to the top edge in front. Repeat behind.



3 Fold the lower right corner up to lie along the top edge. Repeat behind.



4 Fold the new lower right corner up to lie along the top edge—be careful that flap A stays put. Repeat behind.

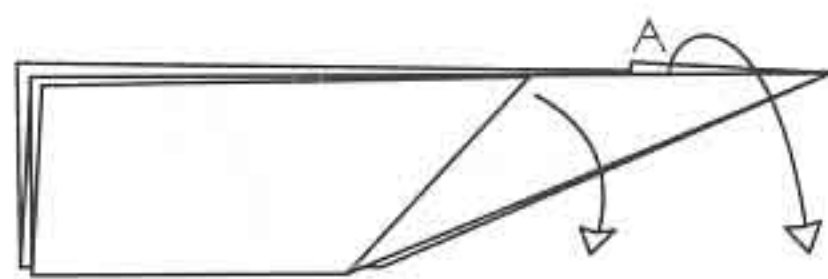

5 Unfold to the beginning of step 3. Repeat behind.

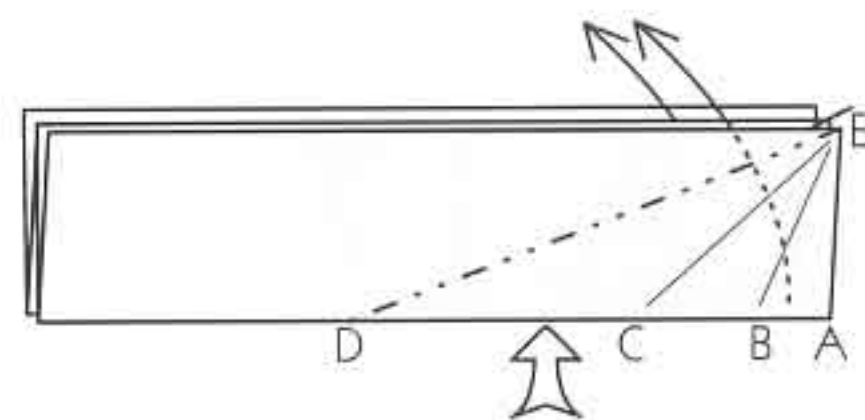

6 Reverse-fold corner A upward along line DE (the crease you just made). Repeat behind.

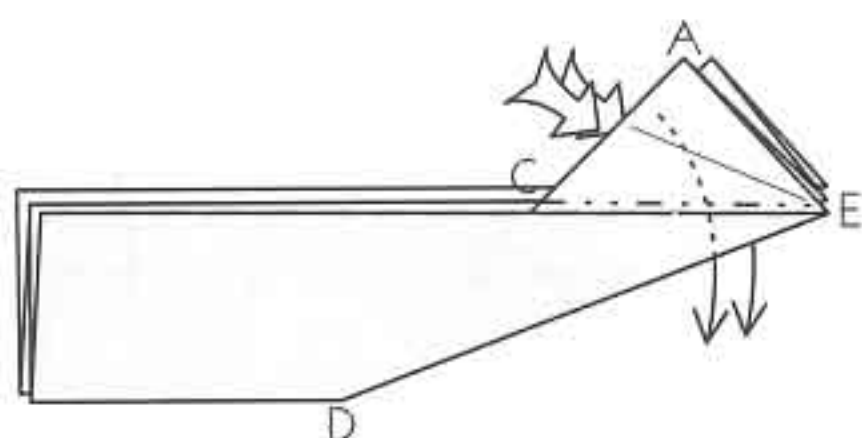

7 Reverse-fold corner A downward along line CE. Repeat behind.

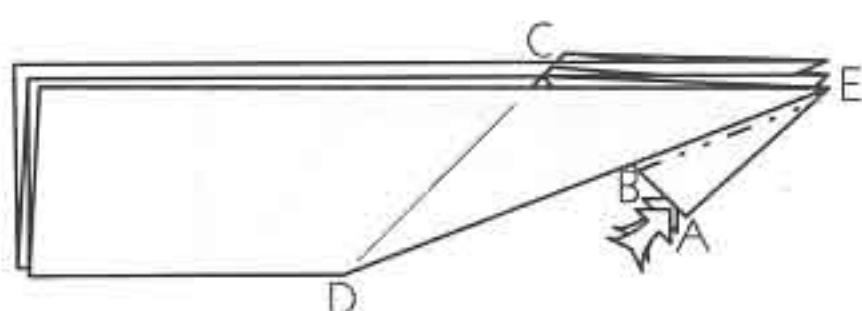

8 Reverse-fold corner A upward along line BE. Repeat behind.

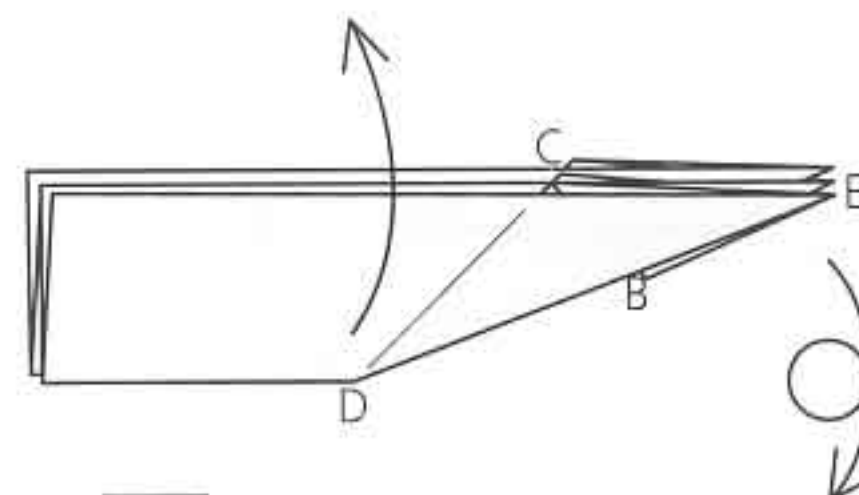

9 Fold corner D upward and turn the model over from top to bottom.

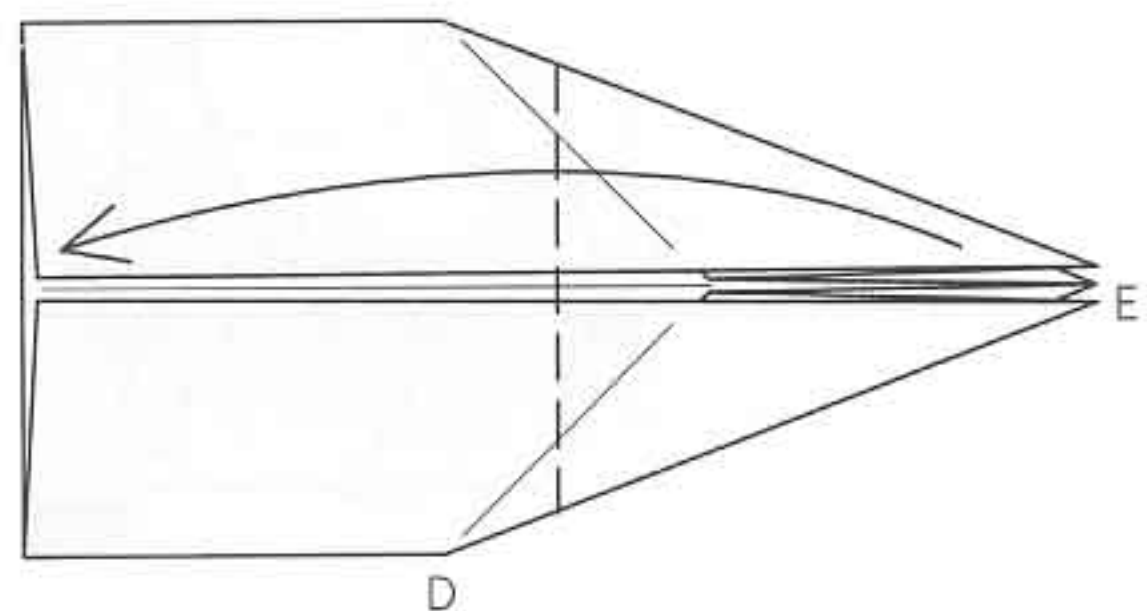

10 Fold point E over to the left edge.

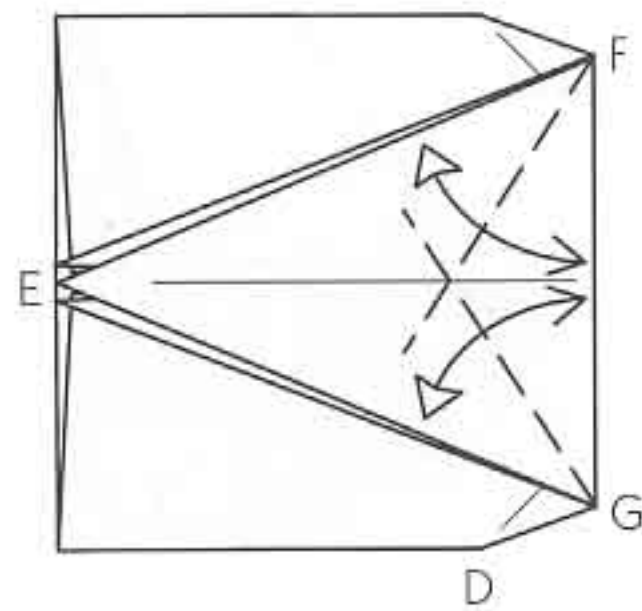

11 Fold edge EG to edge FG, crease, and unfold. Repeat with edge EF.

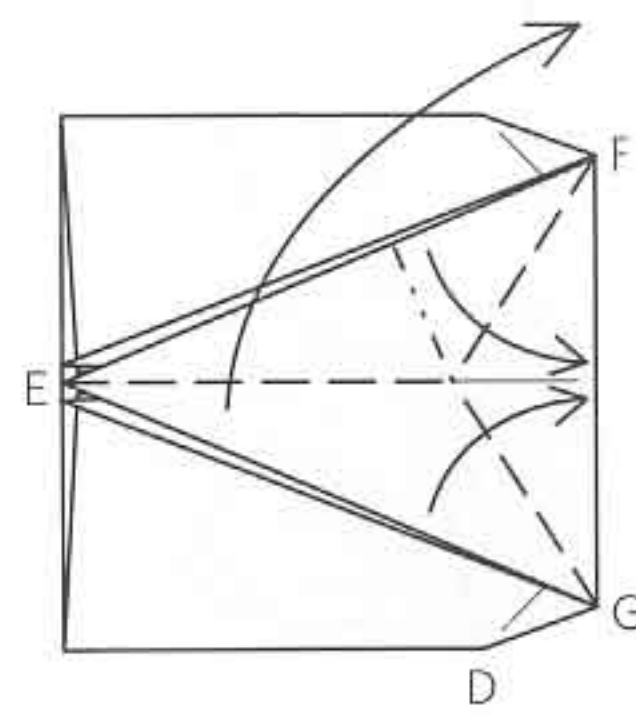

12 Using the creases you just made, fold a rabbit ear from point E and swing the point upward.

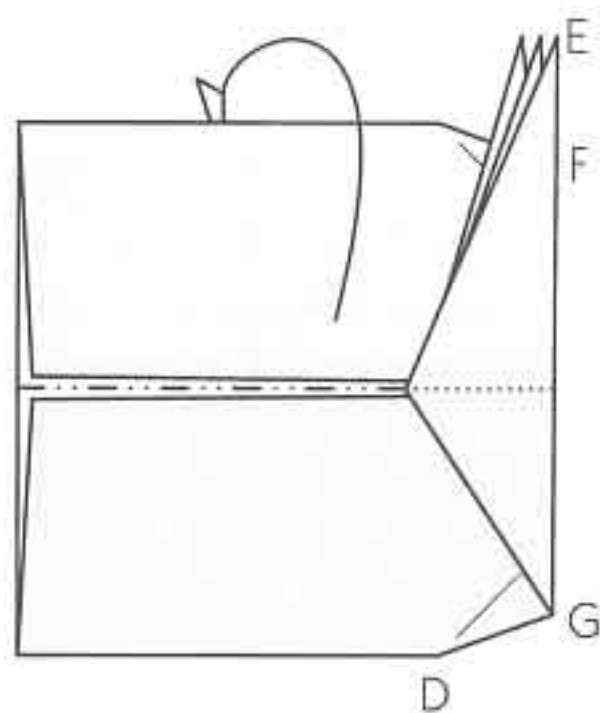

13 Mountain-fold the upper edge behind.

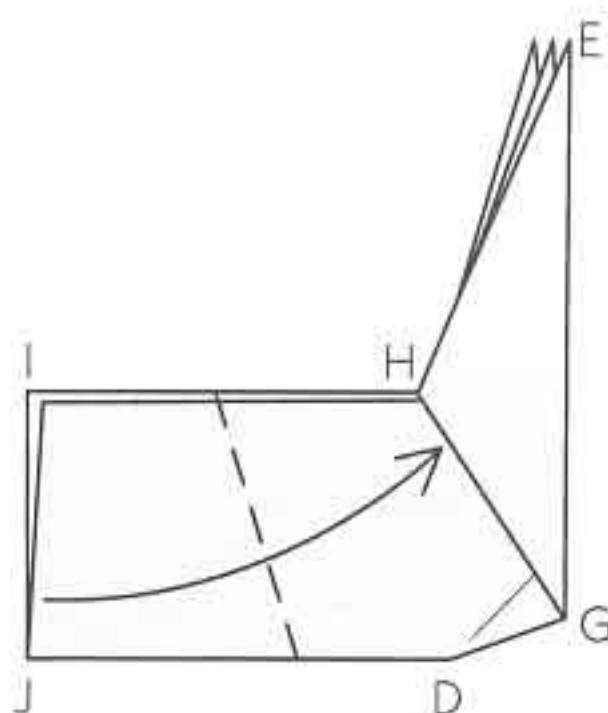

14 Fold edge IJ up to lie along edge HG; point J will wind up about halfway between H and G.

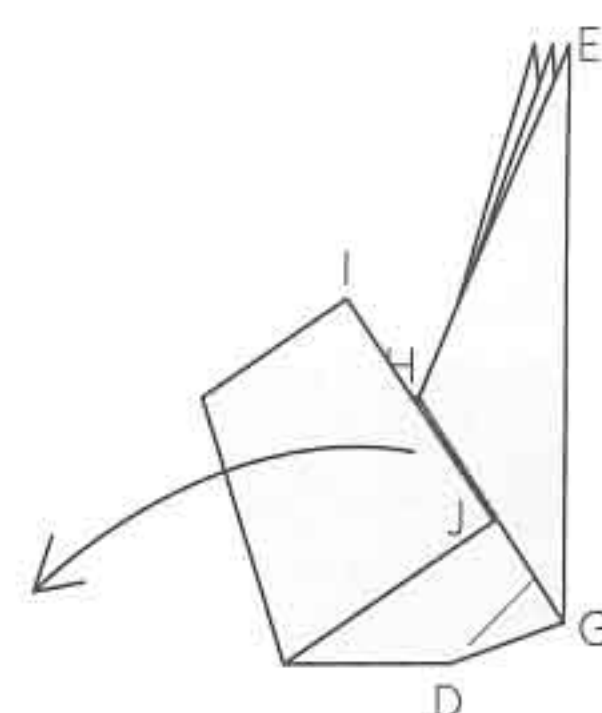

15 Unfold.

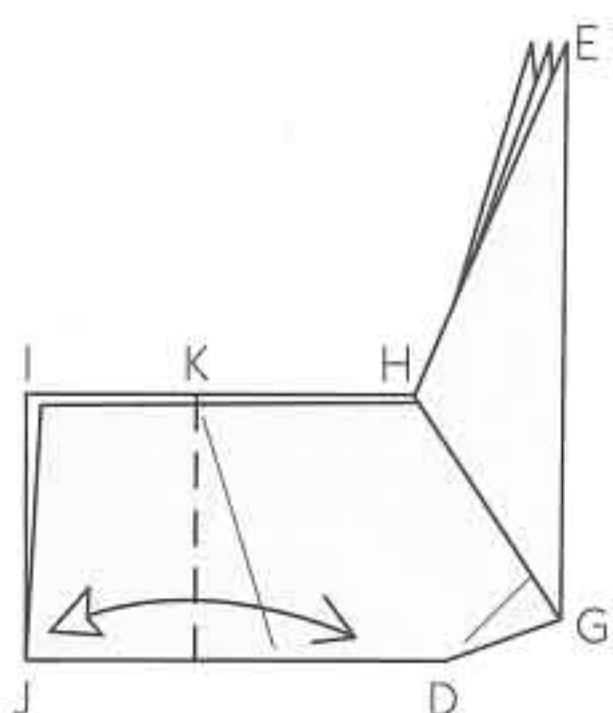

16 Fold the left side of the model to the right so that the crease runs through point K (where the last crease hit the top edge) and so point J stays on edge JD. Unfold.

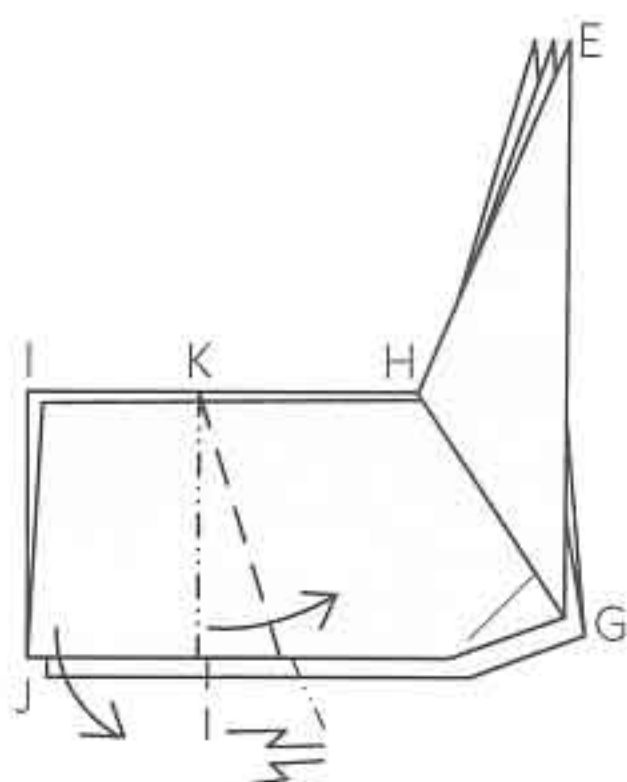

17 Crimp the left side of the model downward, using the creases you just made (some will need to be changed from valley folds to mountain folds and vice-versa).

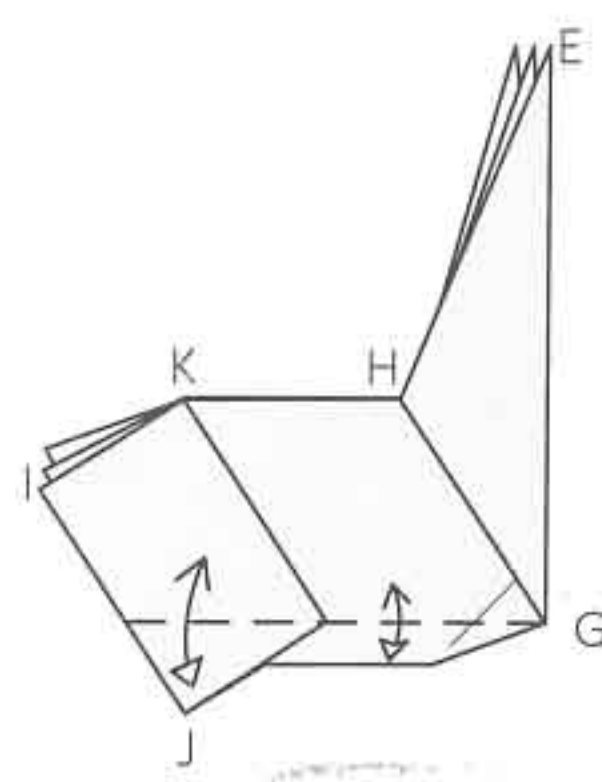

18 Fold and unfold through the near layers along a horizontal crease that runs through point G. Repeat behind.

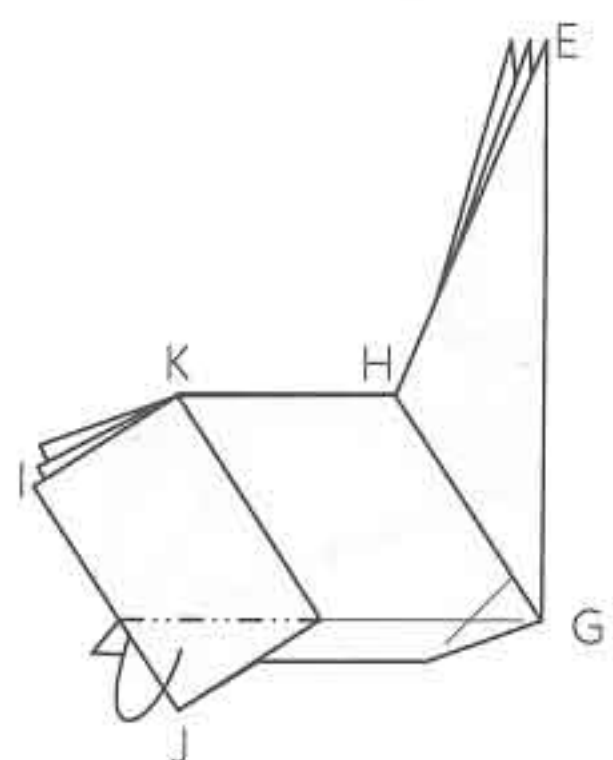

19 Mountain-fold corner J inside along the crease you just made. Repeat behind.

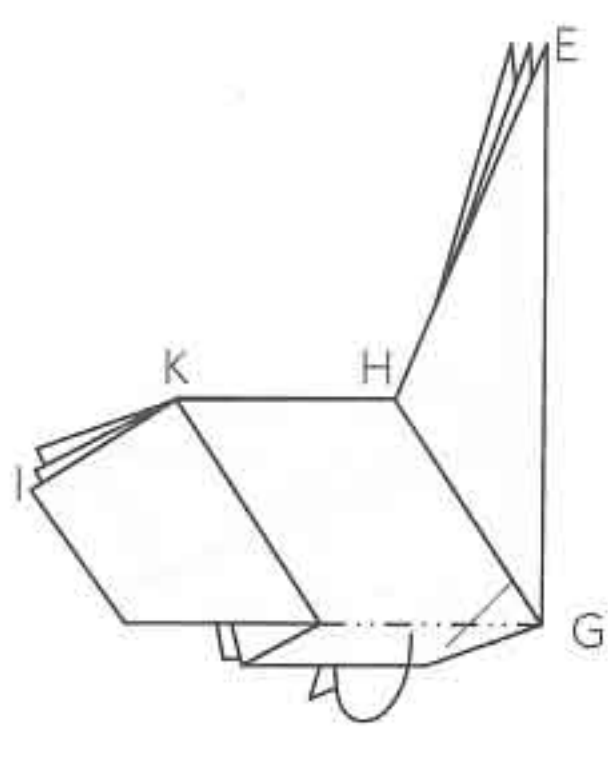

20 Mountain-fold the bottom edge inside. Repeat behind.

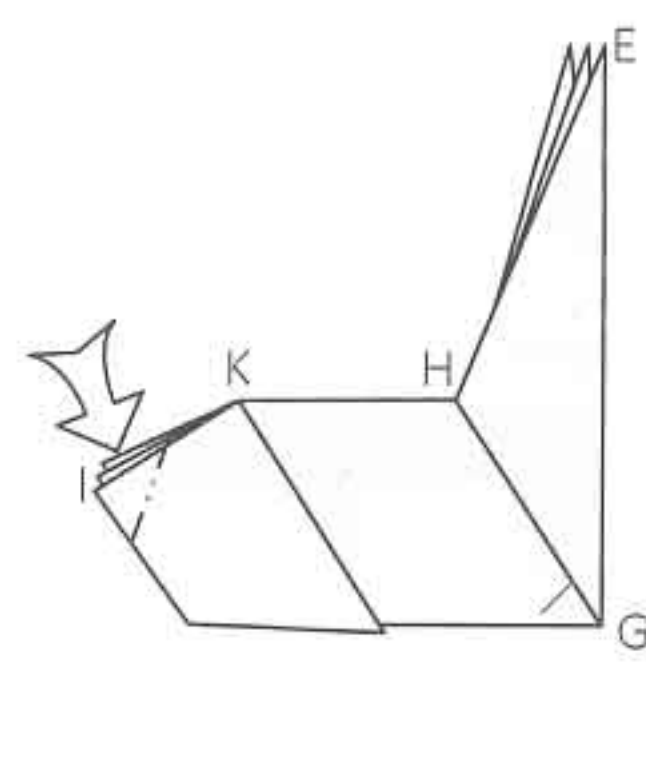

21 Reverse-fold corner I, tucking the loose corners in as well.

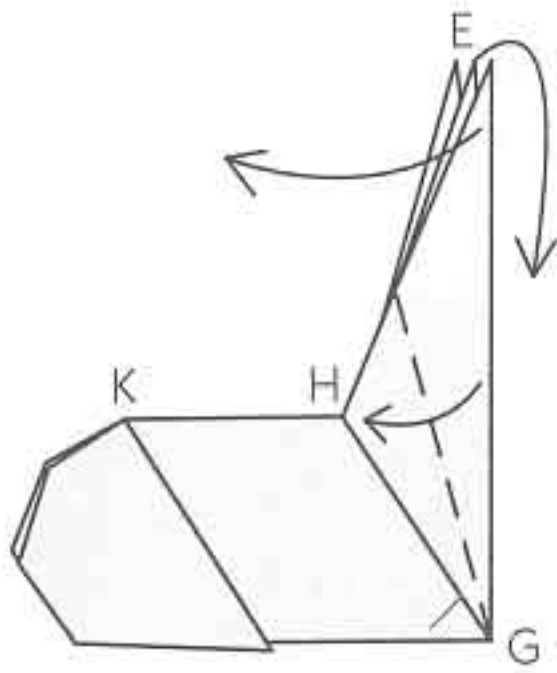

22 Fold two of the layers along edge EG to the left to lie along HG; one of the points at E comes over to the left, while the middle point opens out and begins to swing downward.

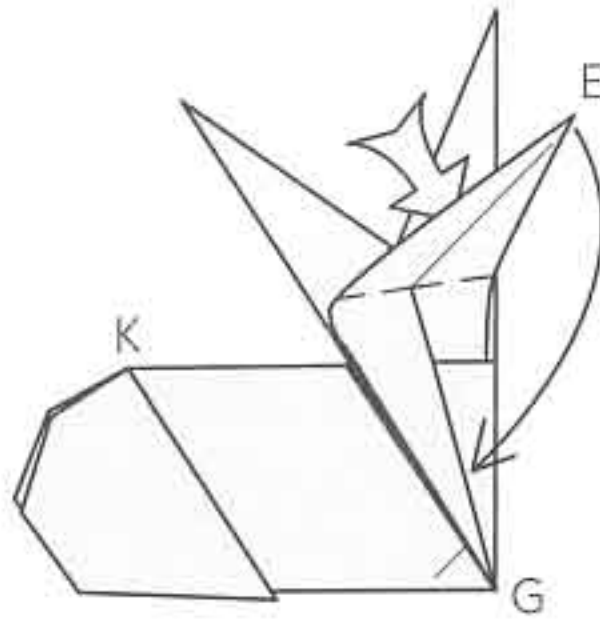

23 Squash-fold point E downward.

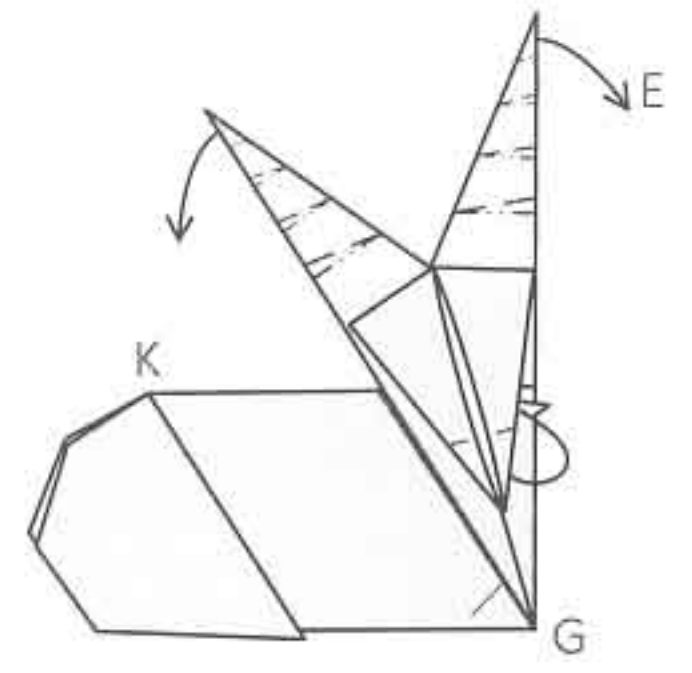

24 Mountain-fold the tip of the nose underneath. Pleat the horns. Note that in in the horn pleats, the lower fold of each pair is the mountain fold while the upper fold is the valley fold.

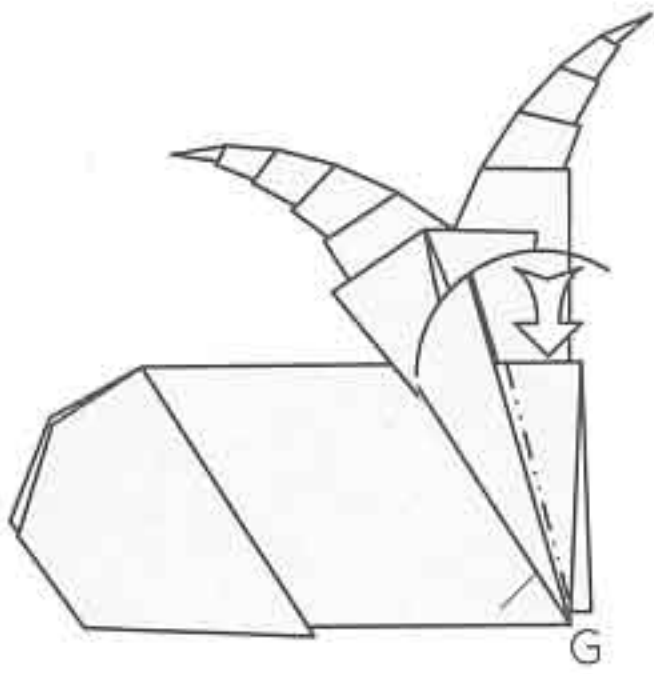

25 Reverse-fold the thick edge that lies behind the head (which is shown cut-away here).

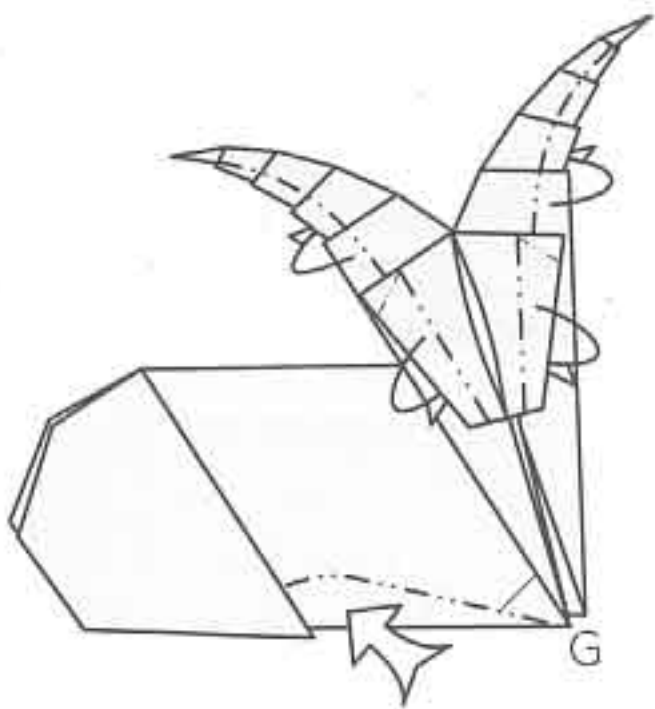

26 Narrow the horns with mountain folds, folding through all layers. Narrow the head by mountain-folding its sides underneath. Round and shape the body.

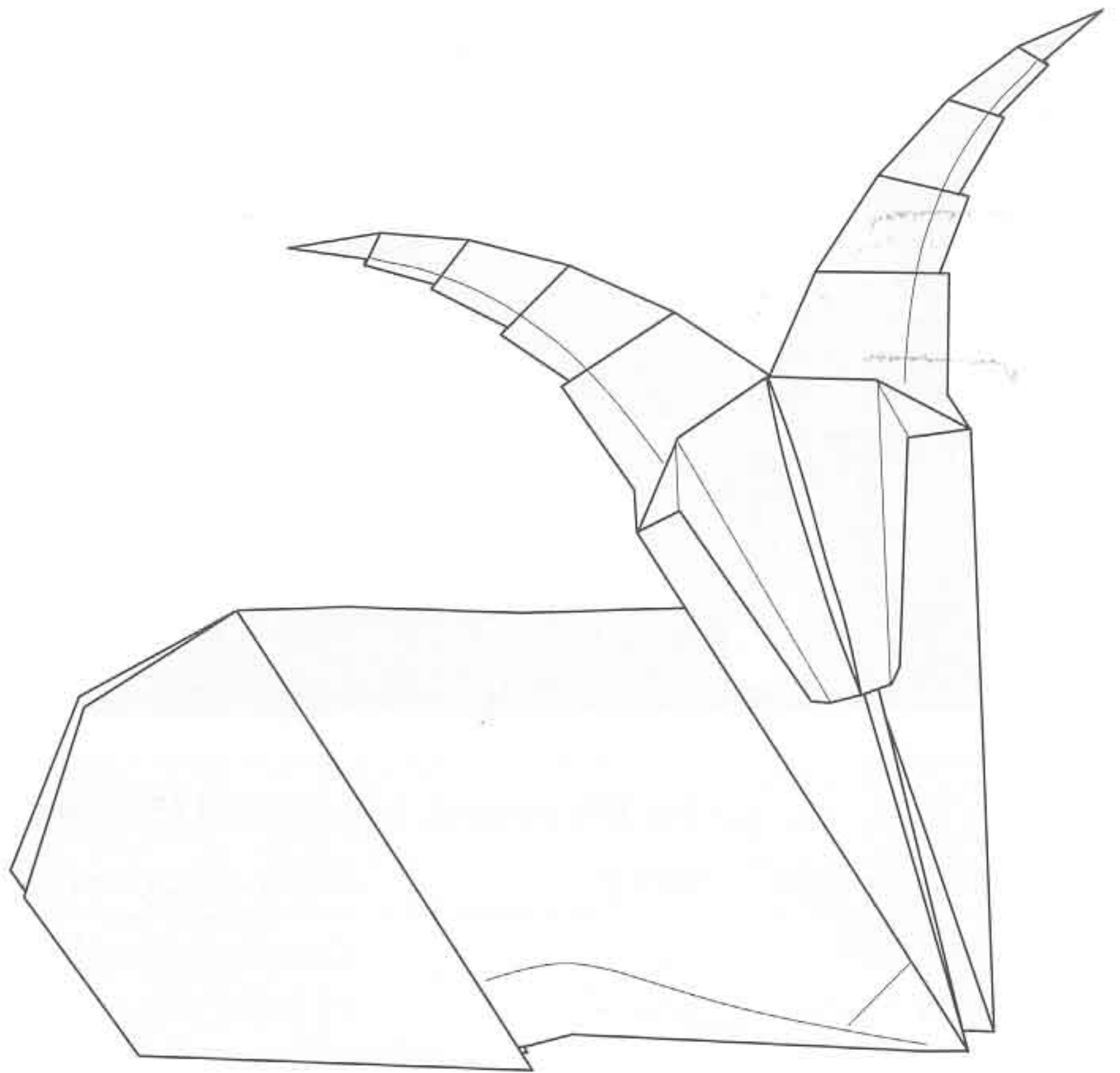

Finished ibex.

◆ Louisiana bayou ◆



For this project, you will fold the following models:

Name	Page	Rating	Paper requirements
Cypress	47	Easy	One large and several small squares of dark brown paper
Alligator	49	Easy	12 in (30 cm) square of green and yellow paper
Crawfish	52	Low Intermediate	5 in (13 cm) square of thin dark green paper
Turtle	56	High Intermediate	12 in (30 cm) square of thin green paper

◆ cypress ◆

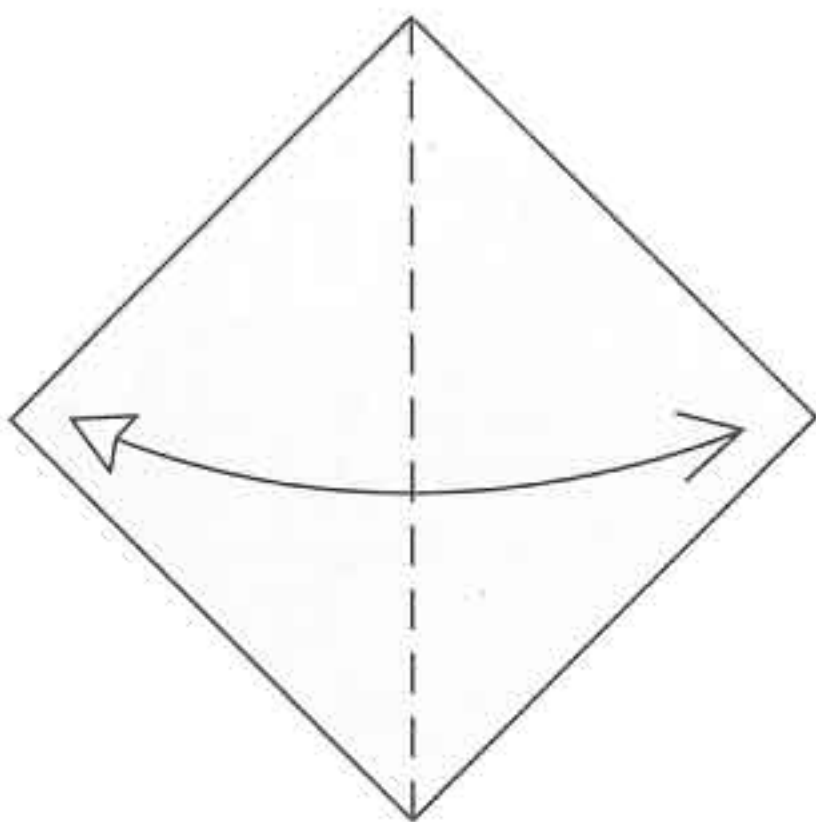
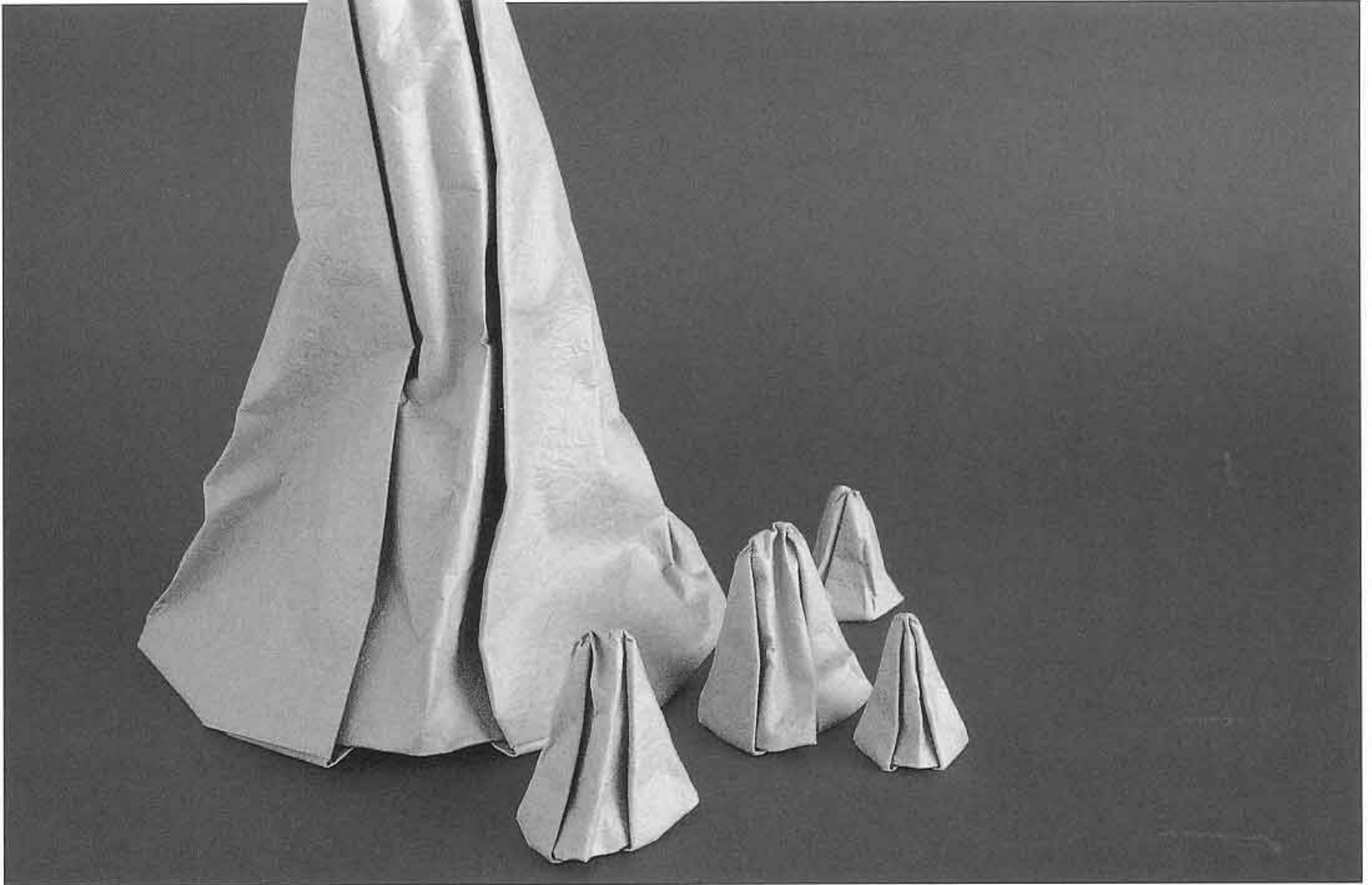

1 Begin with the white side up. Fold the paper in half along the vertical diagonal and unfold.

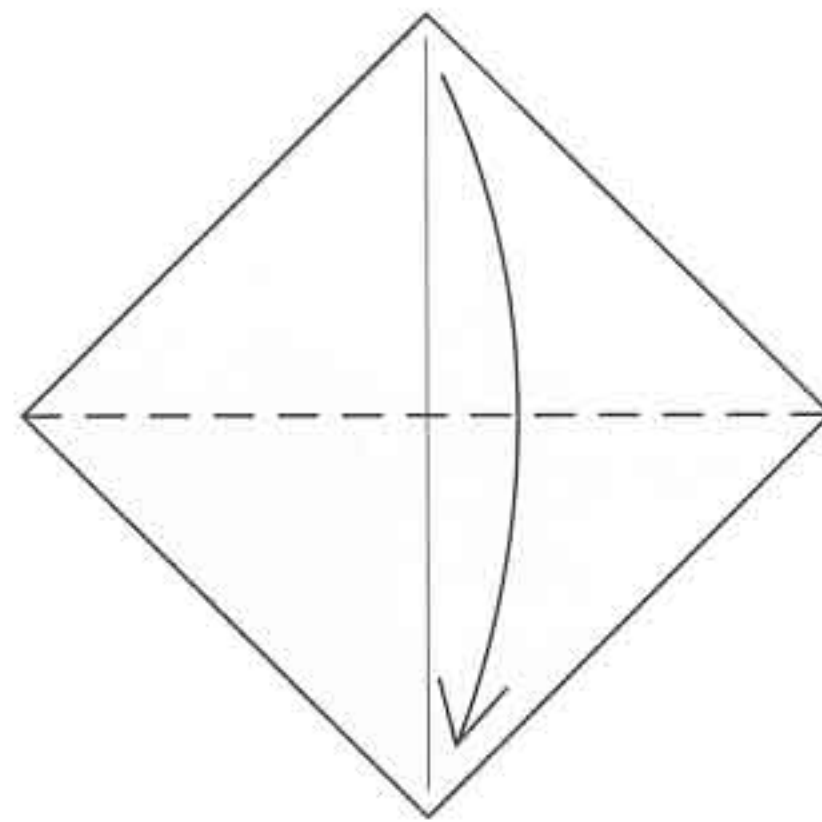

2 Fold the top corner down to the bottom.

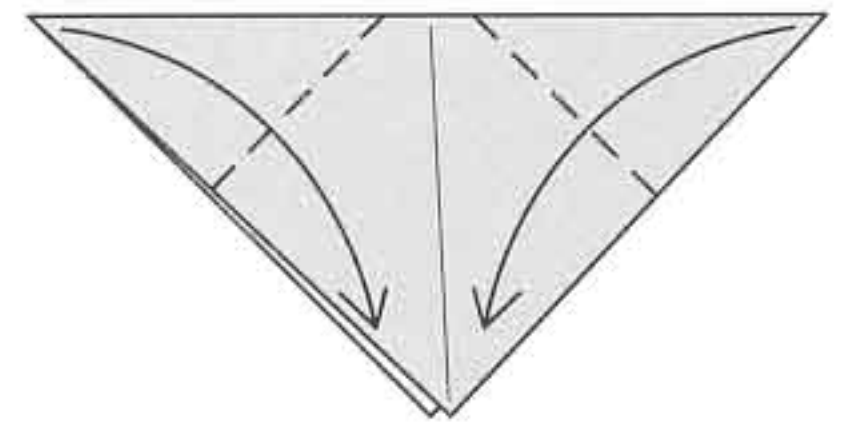

3 Fold the side corners downward, almost all the way to the bottom point. The exact amount isn't critical.

Louisiana bayou

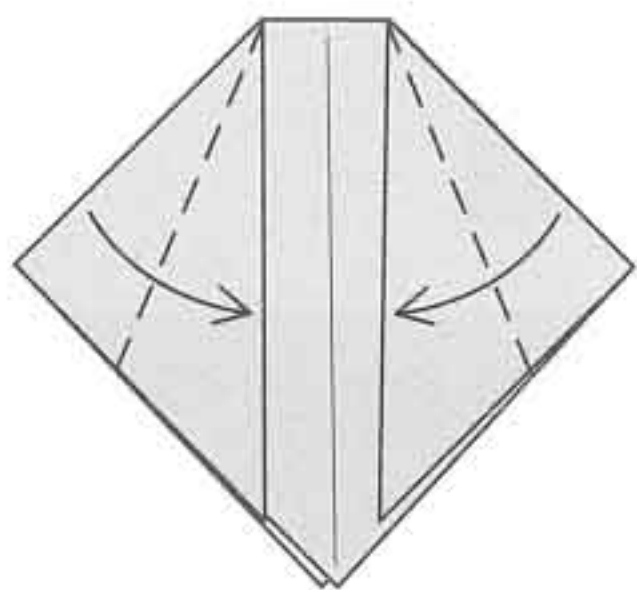

4 Fold the side edges in to lie along the vertical edges.

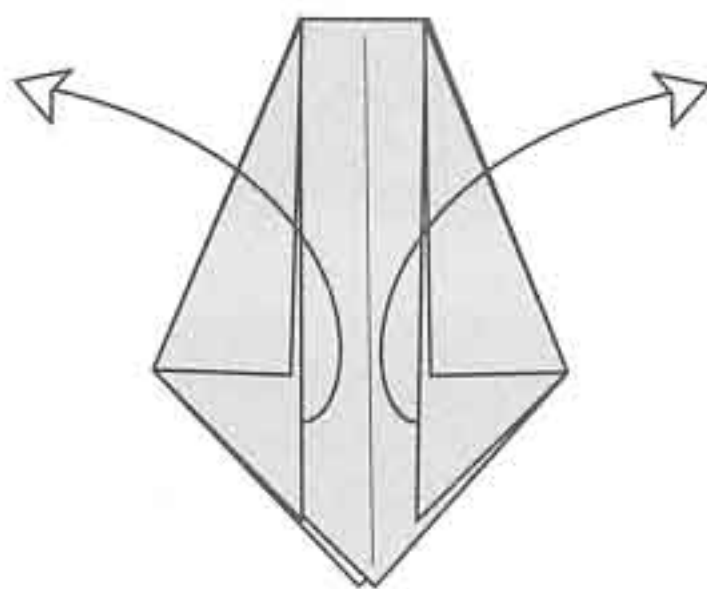

5 Unfold to the beginning of step 3.

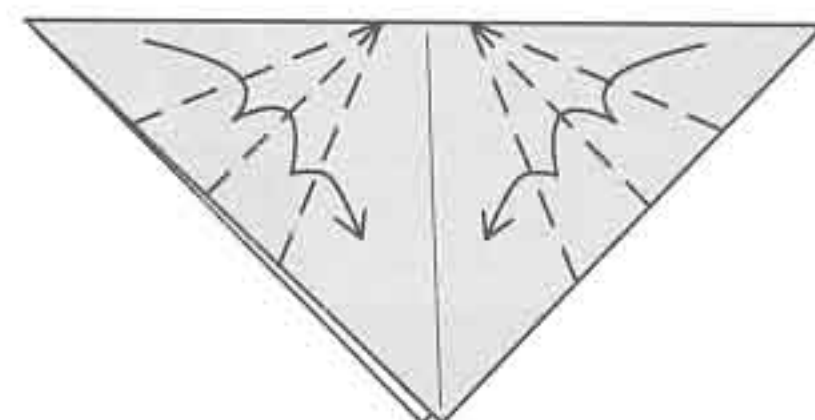

6 Fold the side corners over and over on the existing creases.

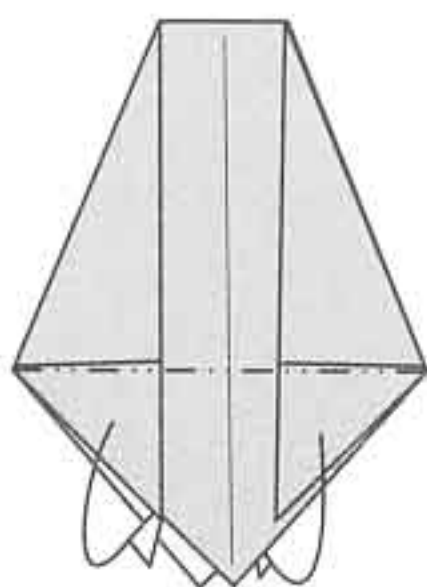

7 Mountain-fold the three near flaps into the inside of the model.

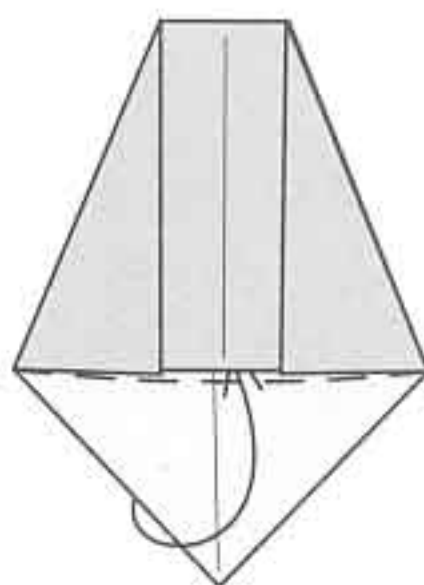

8 Valley-fold the remaining flap up into the model.

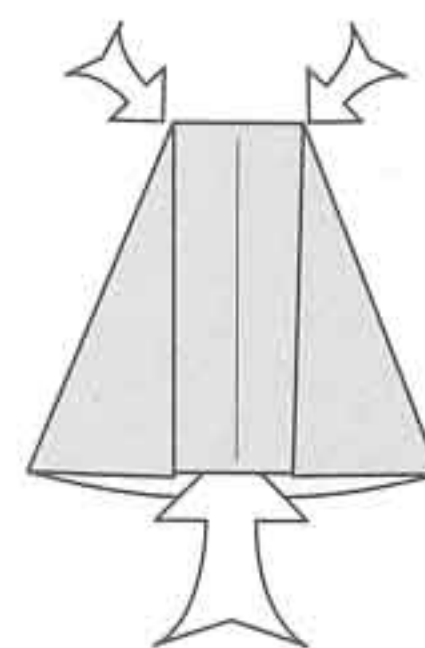

9 Open out the bottom of the cone shape and blunt the top corners.

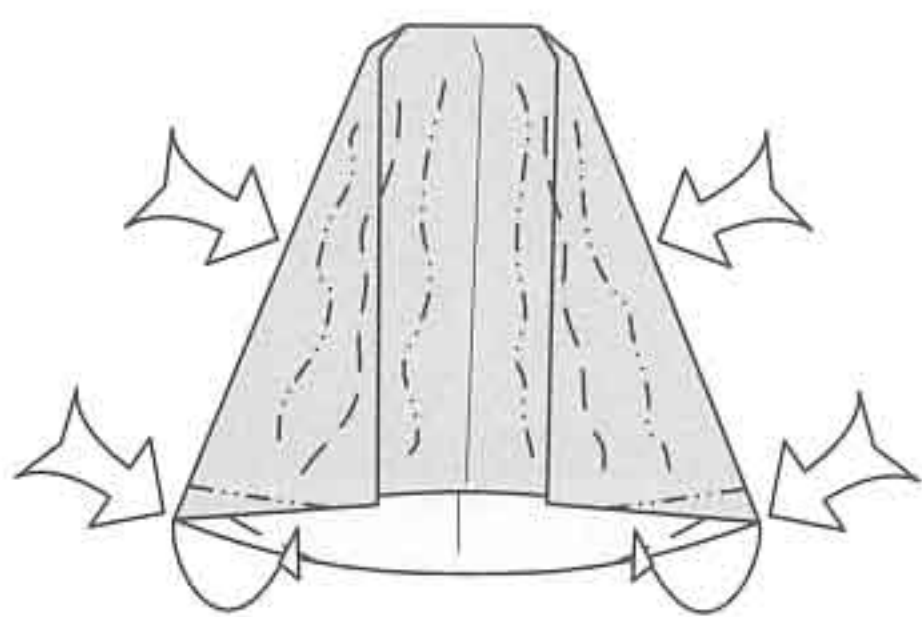

10 Crumple the cone by pushing in the sides all around to give the stump a rough, bark-like texture. You can fold a bit of the bottom underneath so it stands evenly. Make one large shape for the main stump and five to ten smaller ones for the roots.

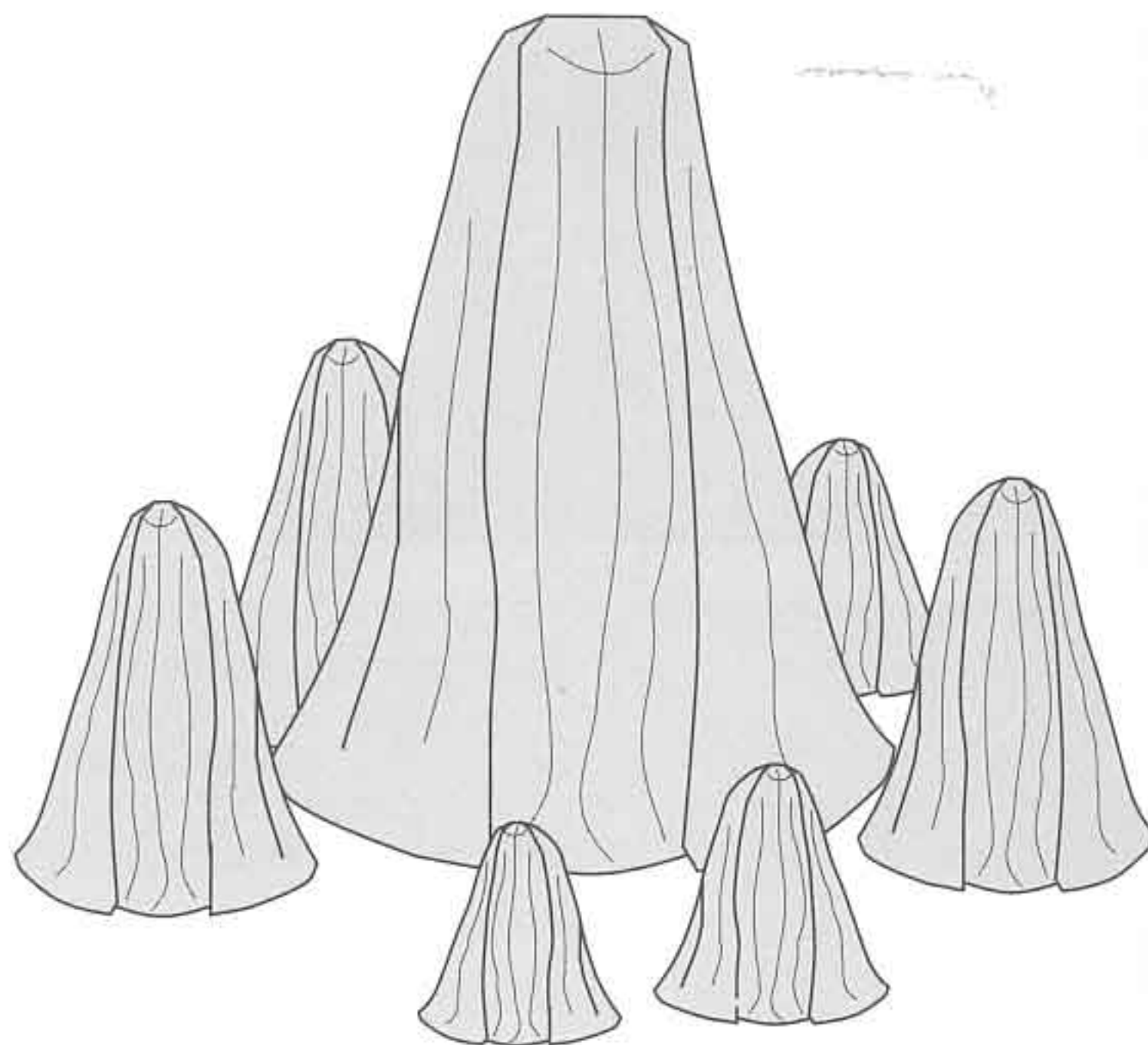

Finished Cypress.

◆ alligator ◆

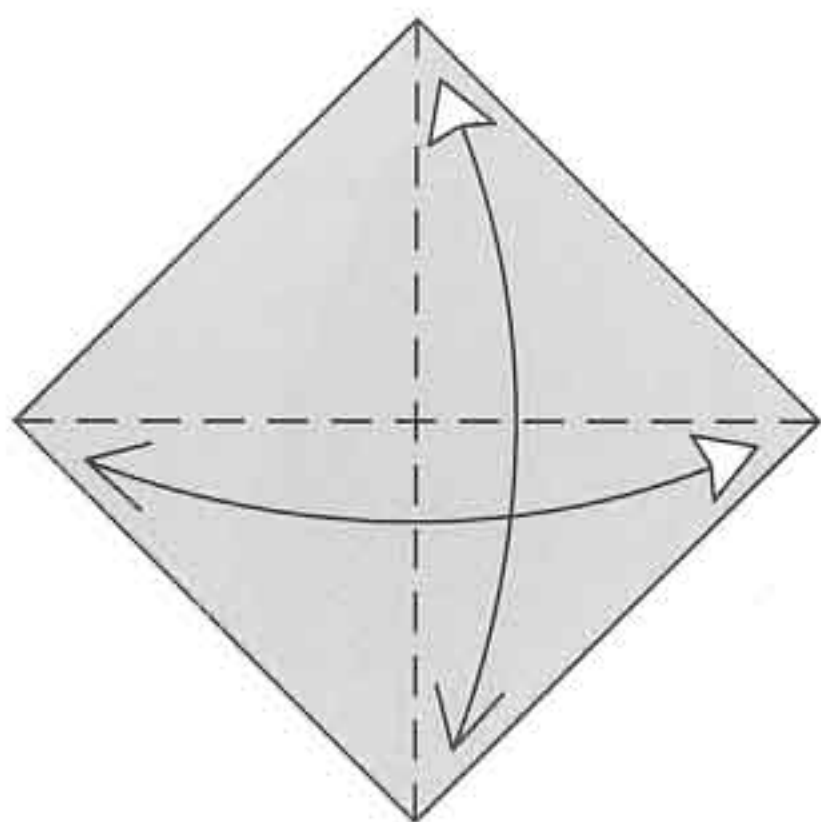
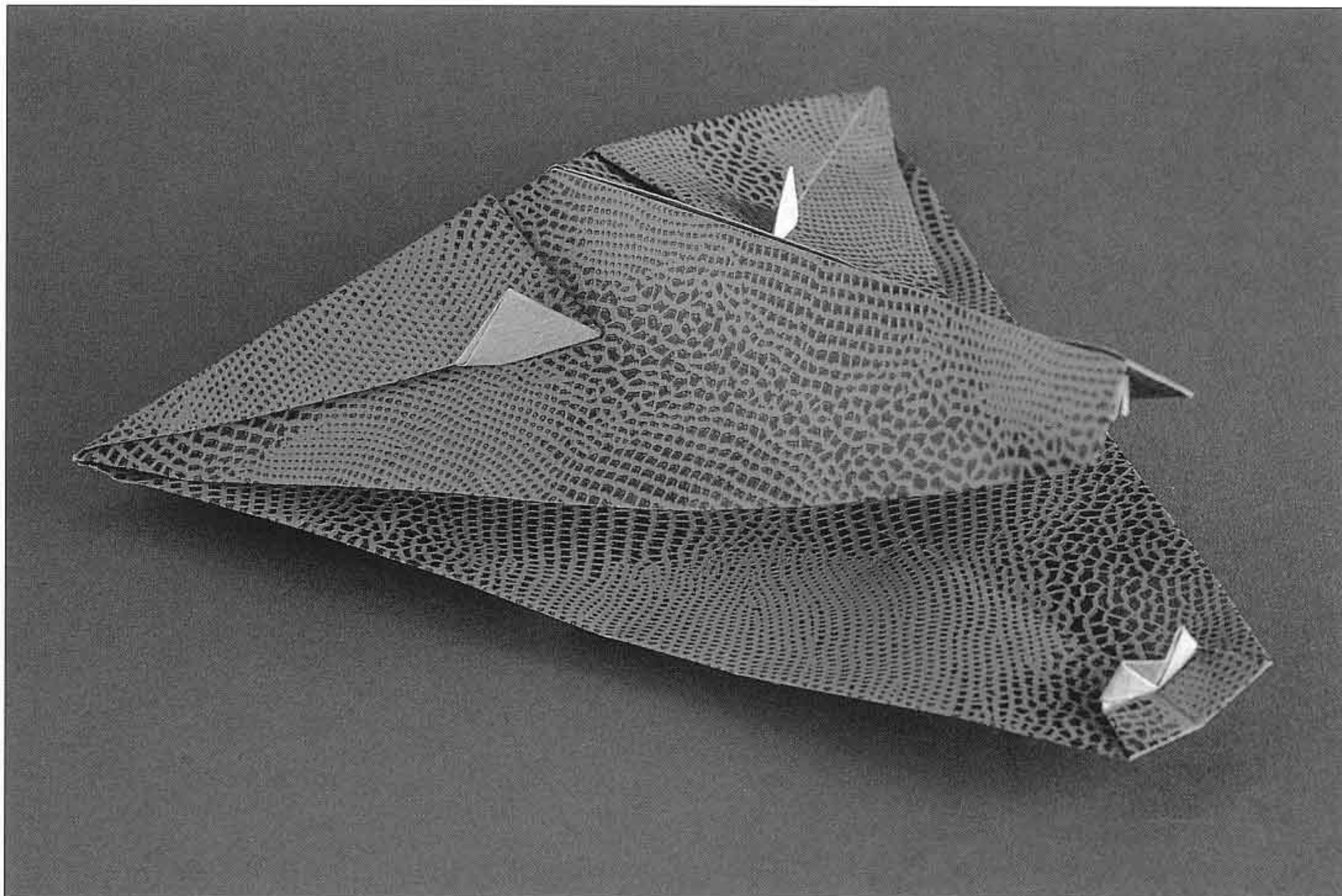

1 Begin with the colored side up. Fold the paper in half along both diagonals and unfold.

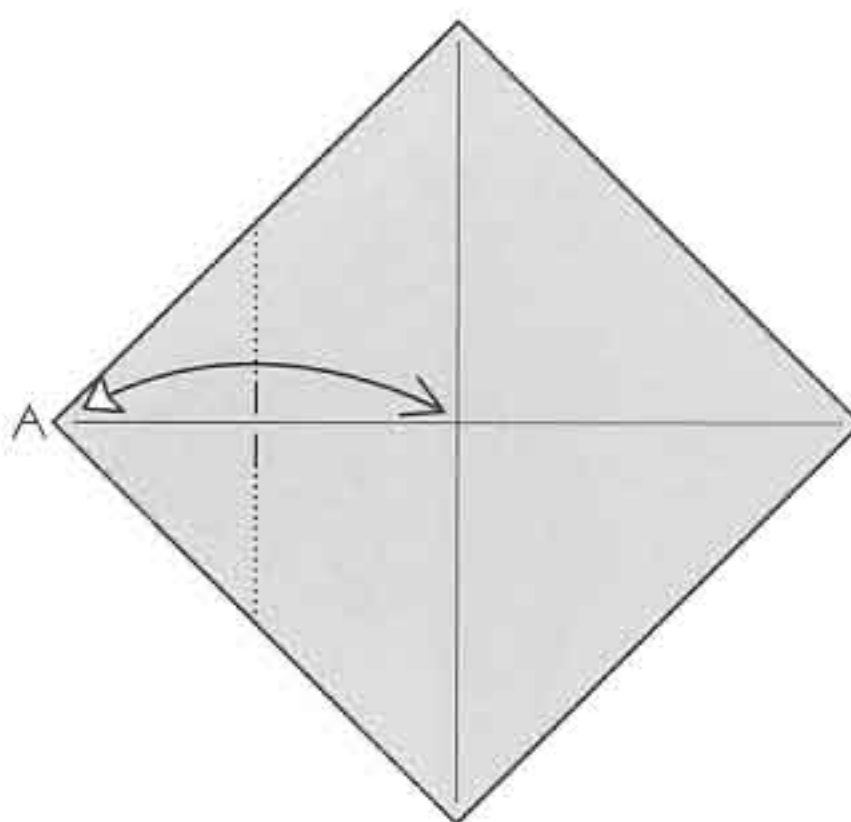

2 Fold point A in to the center and unfold, making the crease sharp only where it crosses the horizontal crease.

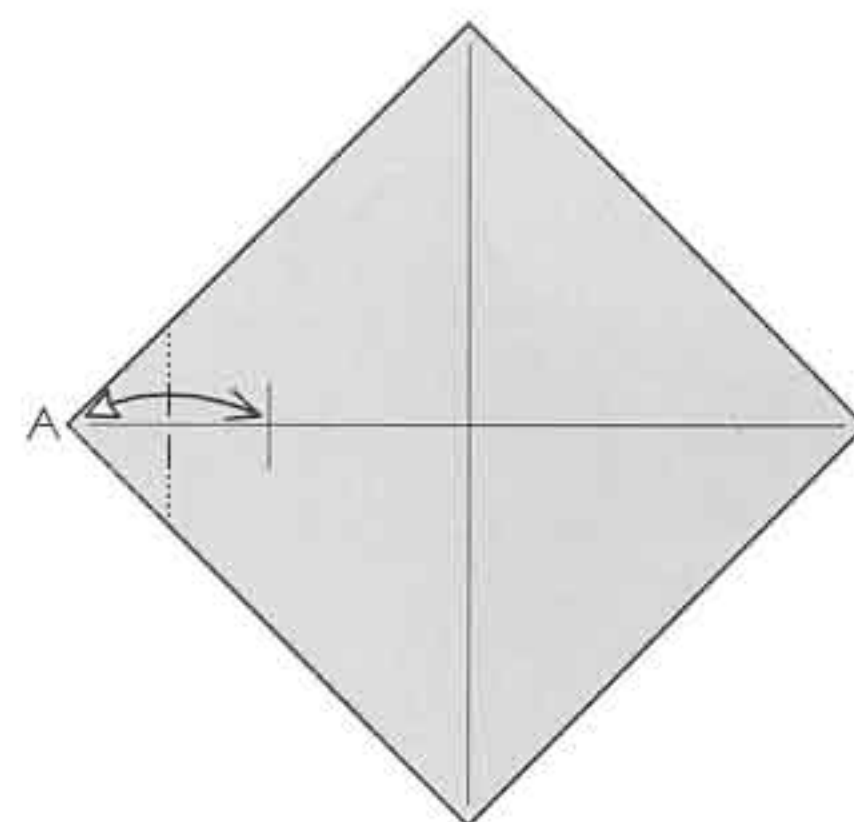

3 Fold point A in to the crease you just made and unfold, making the crease sharp only where it crosses the horizontal crease.

Louisiana bayou

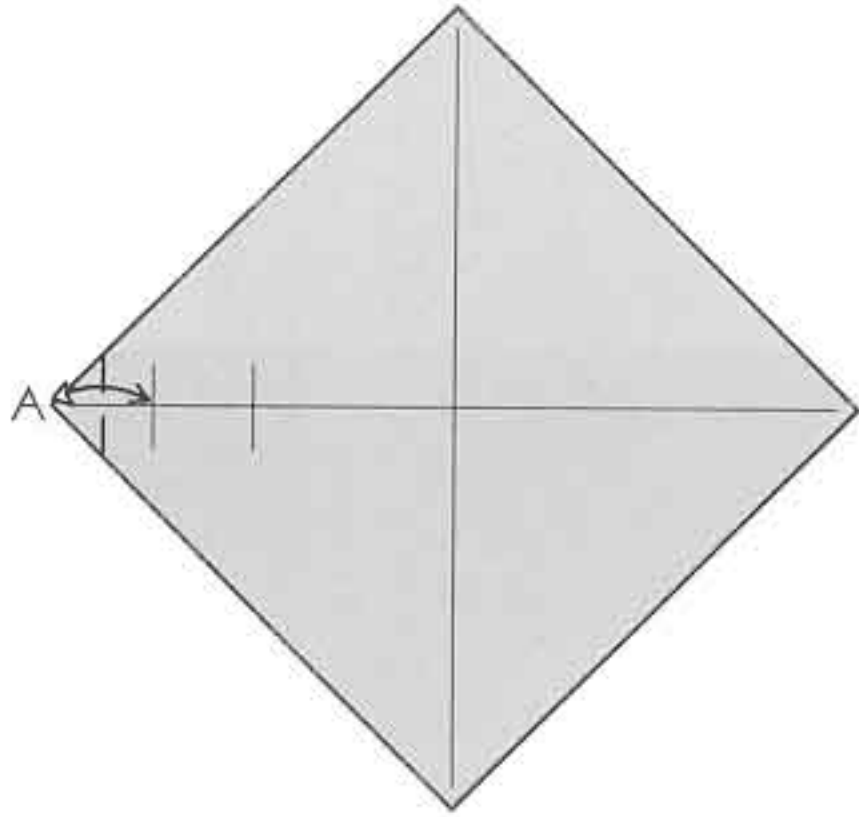

4 Fold point A in to the crease you just made. Unfold. This time, make the crease run all the way across the paper.

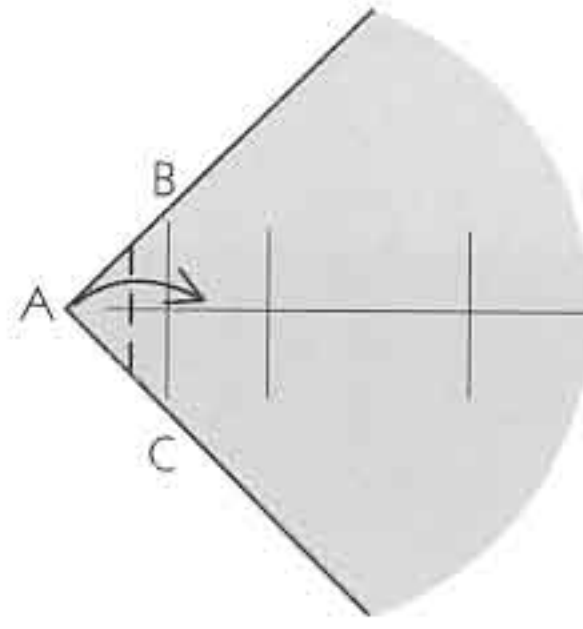

5 This is an enlarged view of the corner. Fold point A in so that crease BC (the crease you just made) cuts across the middle of the white triangle you are making.

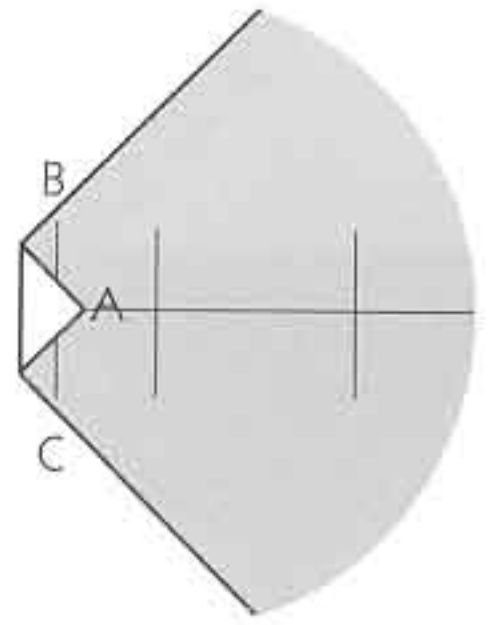

6 This corner is complete. Now repeat steps 3–5 on each of the other three corners.

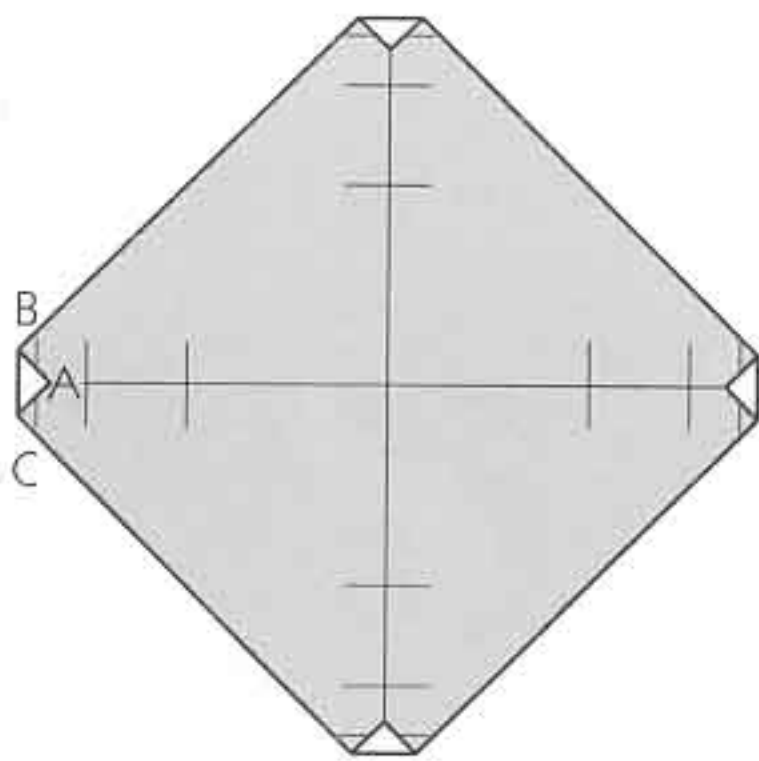

7 Turn the paper over.

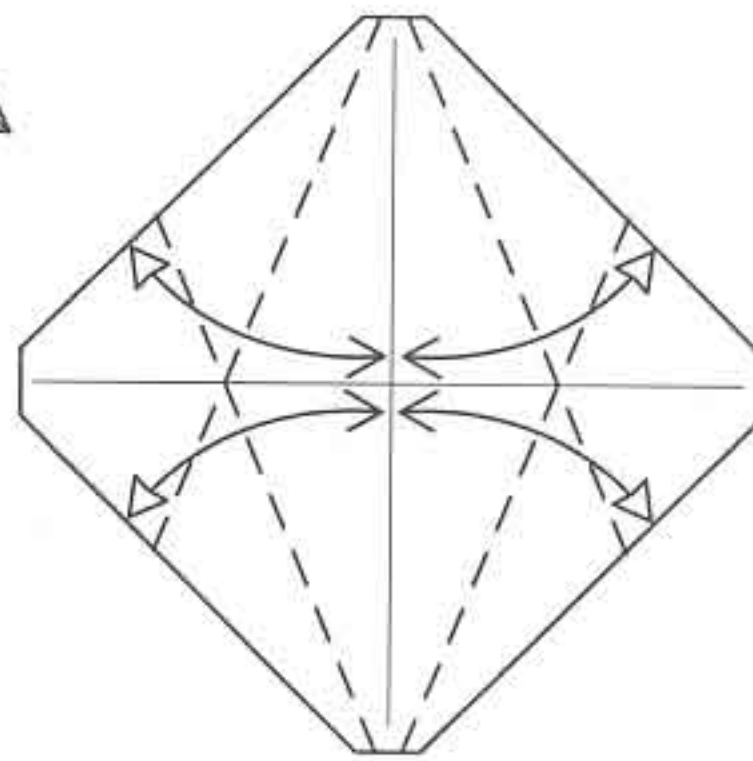
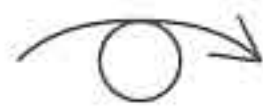

8 Fold each of the four edges in to the center line and unfold.

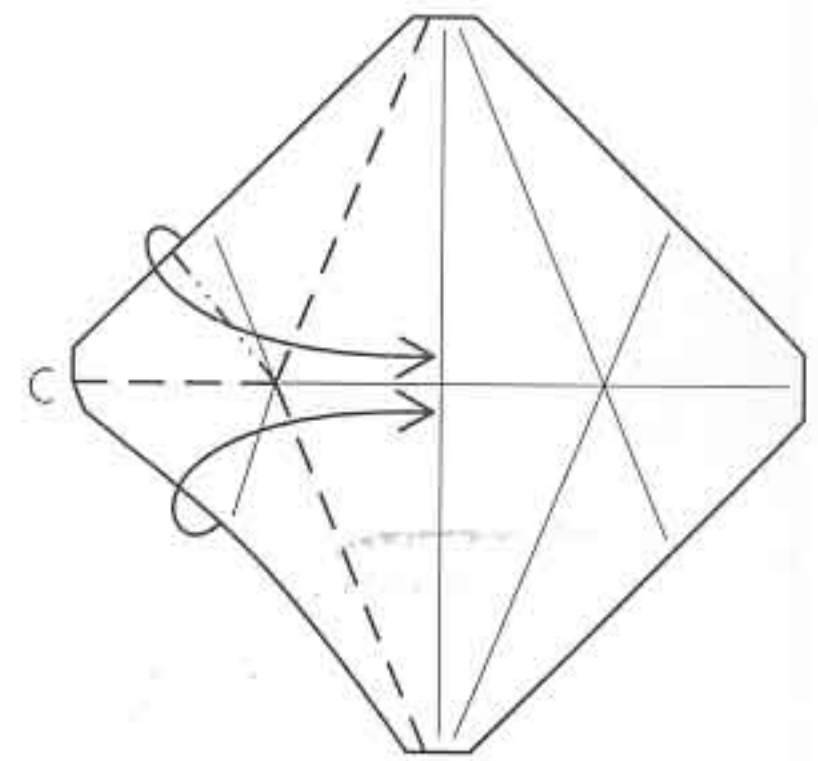

9 Fold the two left edges in to the center together; at the same time, pinch corner D in half. The next step shows this in progress.

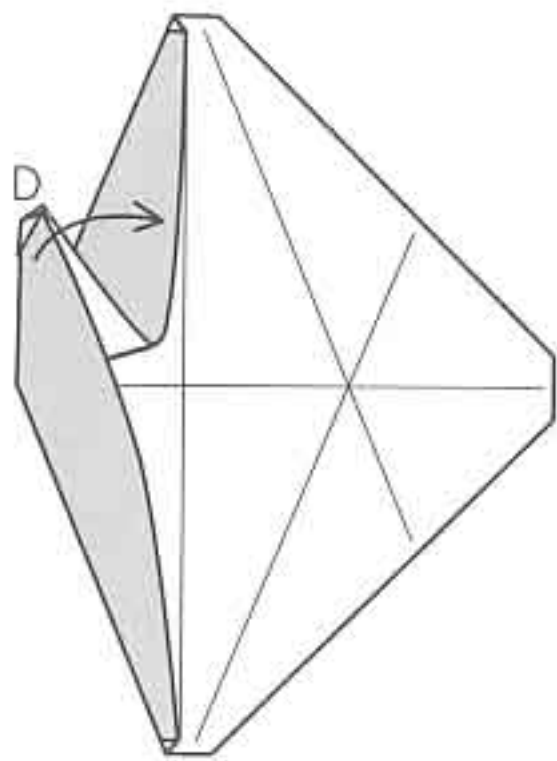

10 Flatten point D upward.

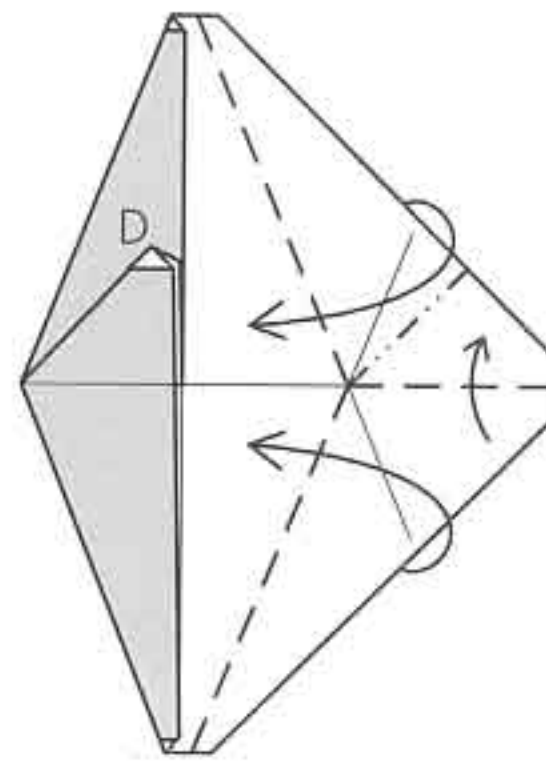

11 Repeat steps 9–10 on the right.

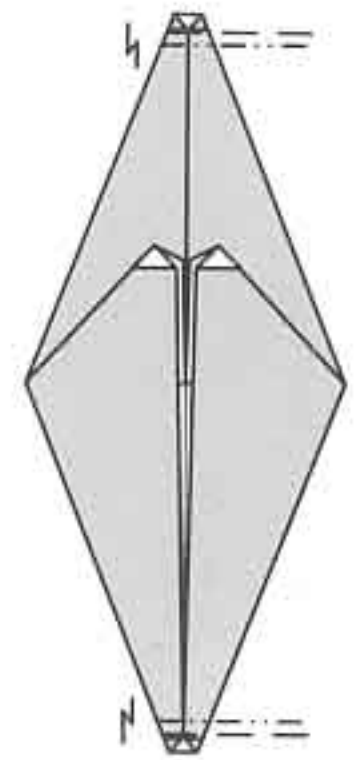

12 Pleat the top and bottom corners—see the next step for a close-up view of the top.

alligator

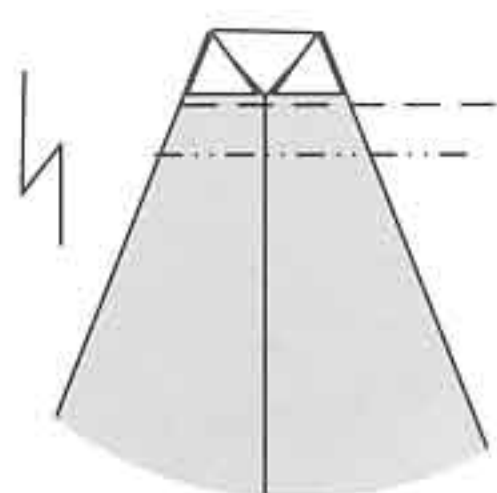

13 Enlarged view of the pleat. Turn the paper over.

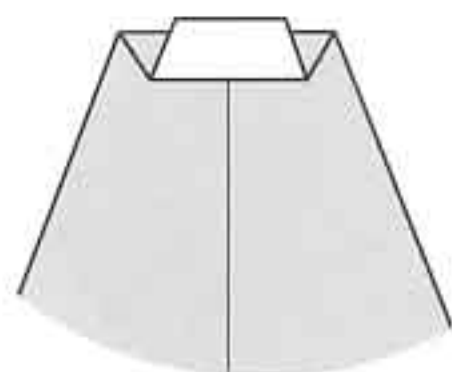

14 This shows the completed pleat at the top; the bottom should look the same.

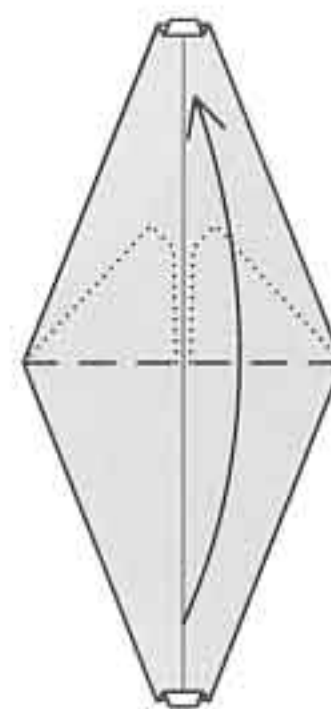

15 Valley-fold the bottom flap upward. The flaps on the back side should be pointing upward. Turn the model over.

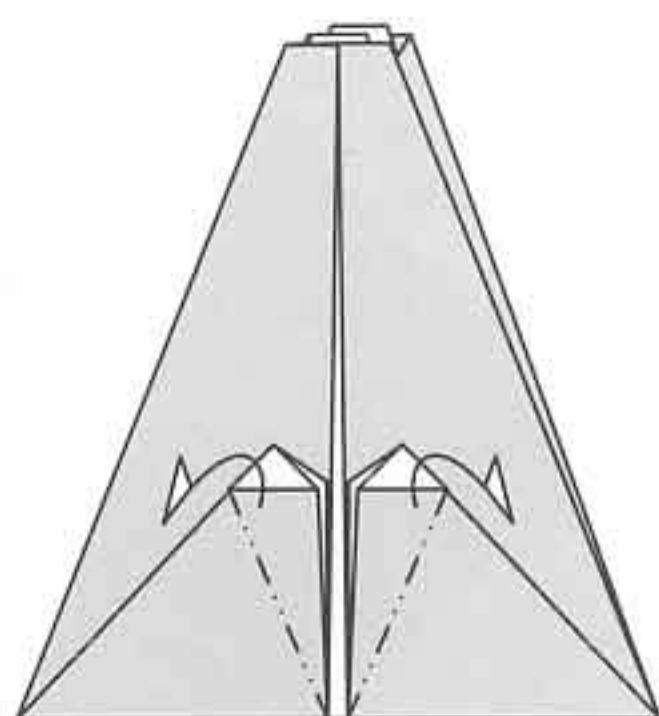

16 Mountain-fold the white corners underneath.

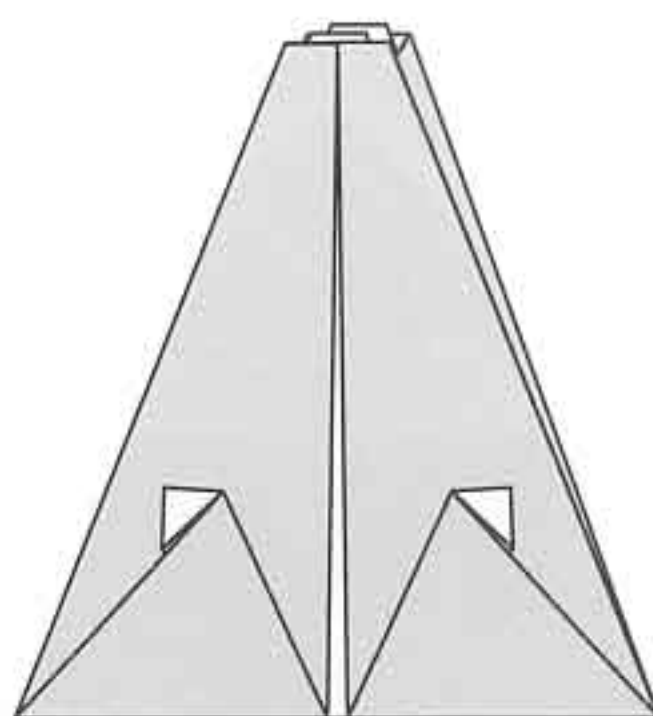

17 Turn the model over.

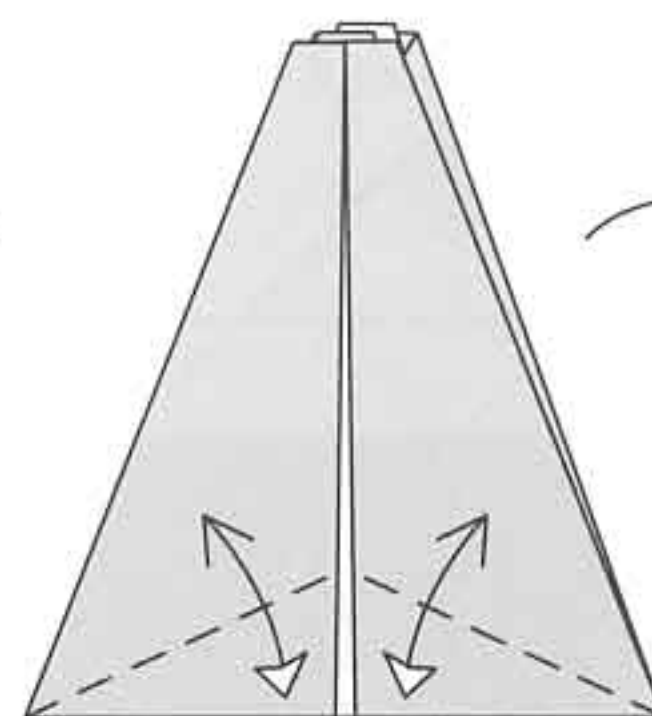
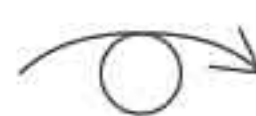

18 Fold and unfold through all layers. Turn the model back over.

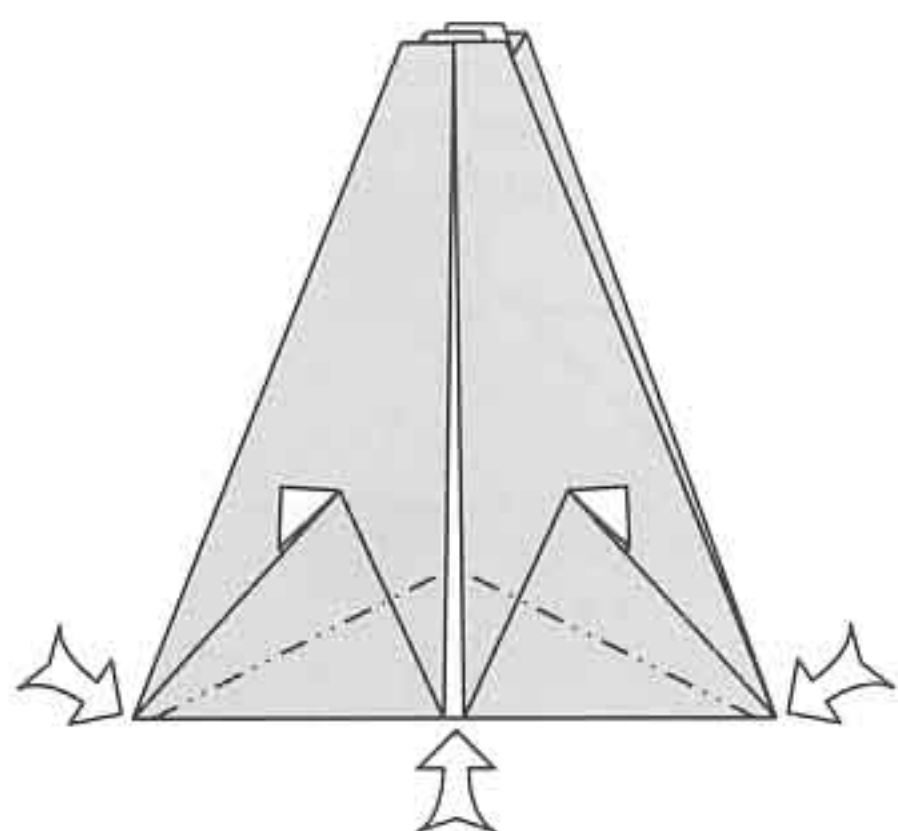
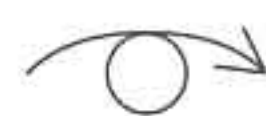

19 Dent the bottom edge upward and simultaneously push in the side corners. The model will become three-dimensional and will open and close its jaws.

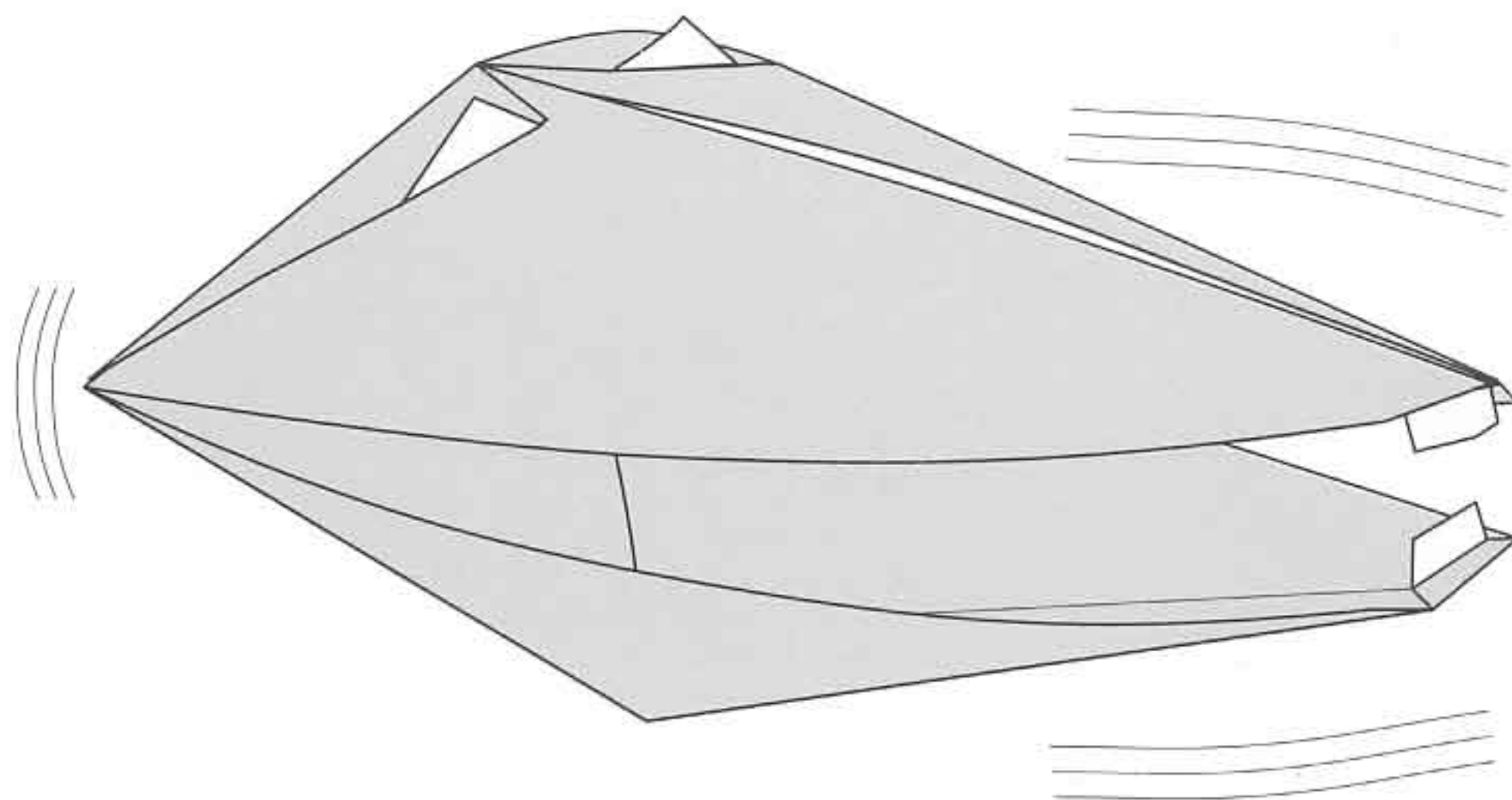

Finished Alligator.

◆ crawfish ◆

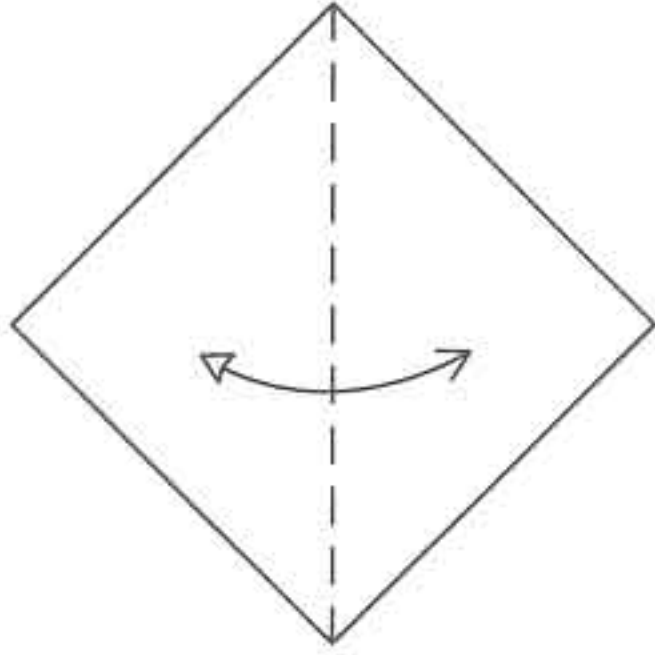

1 Begin with the white side up. Fold and unfold along the diagonal.

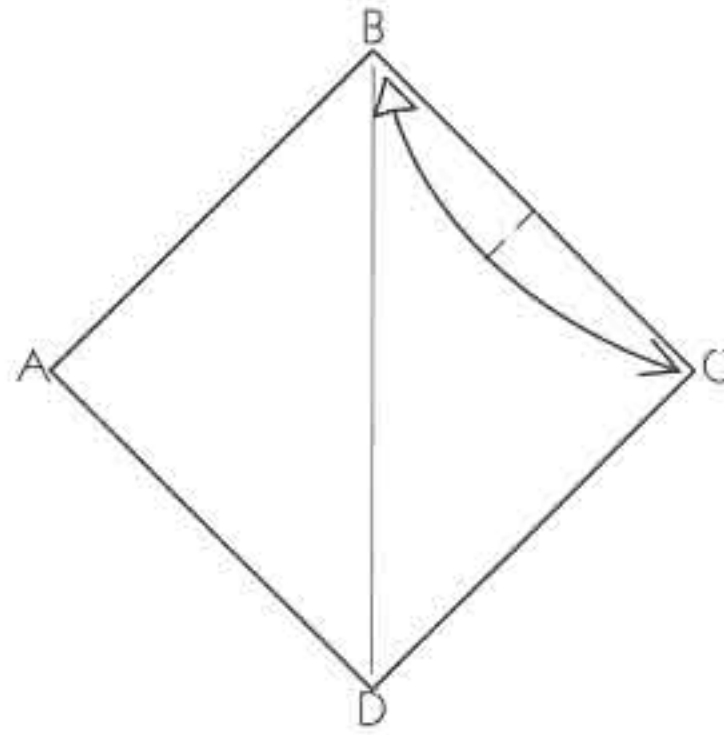

2 Fold corner B down to corner C; pinch along the edge and unfold.

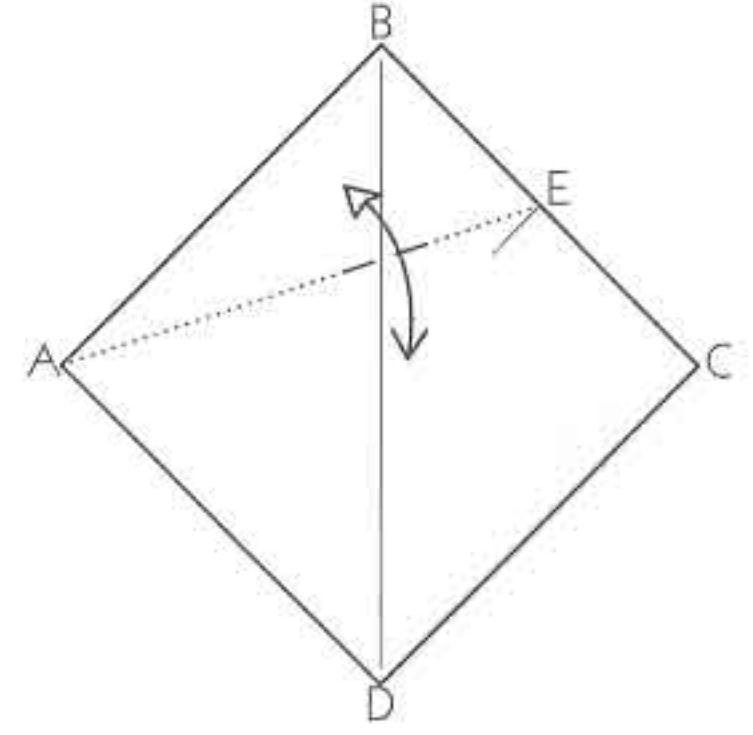

3 Make a crease that runs from point A to point E, making it sharp only where it crosses the diagonal crease BD.

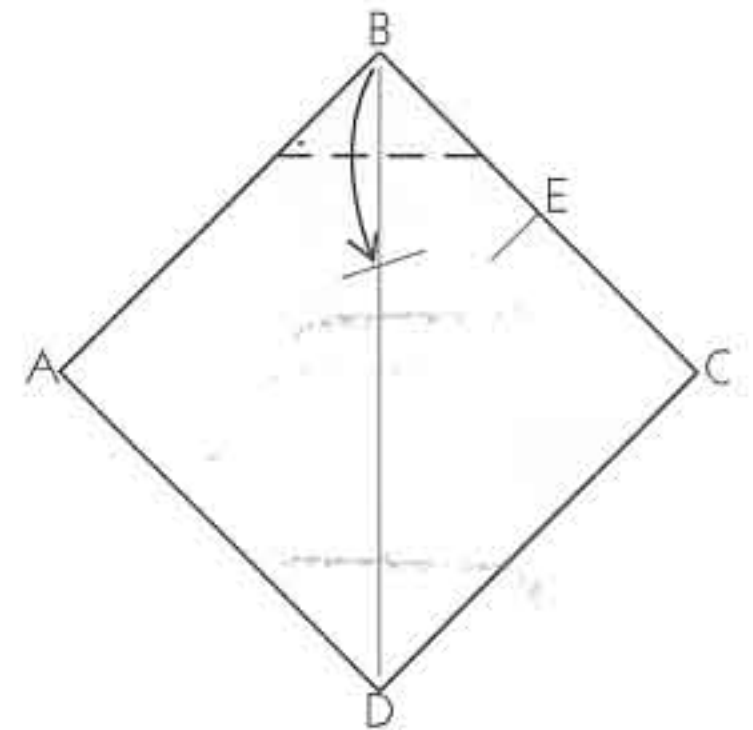
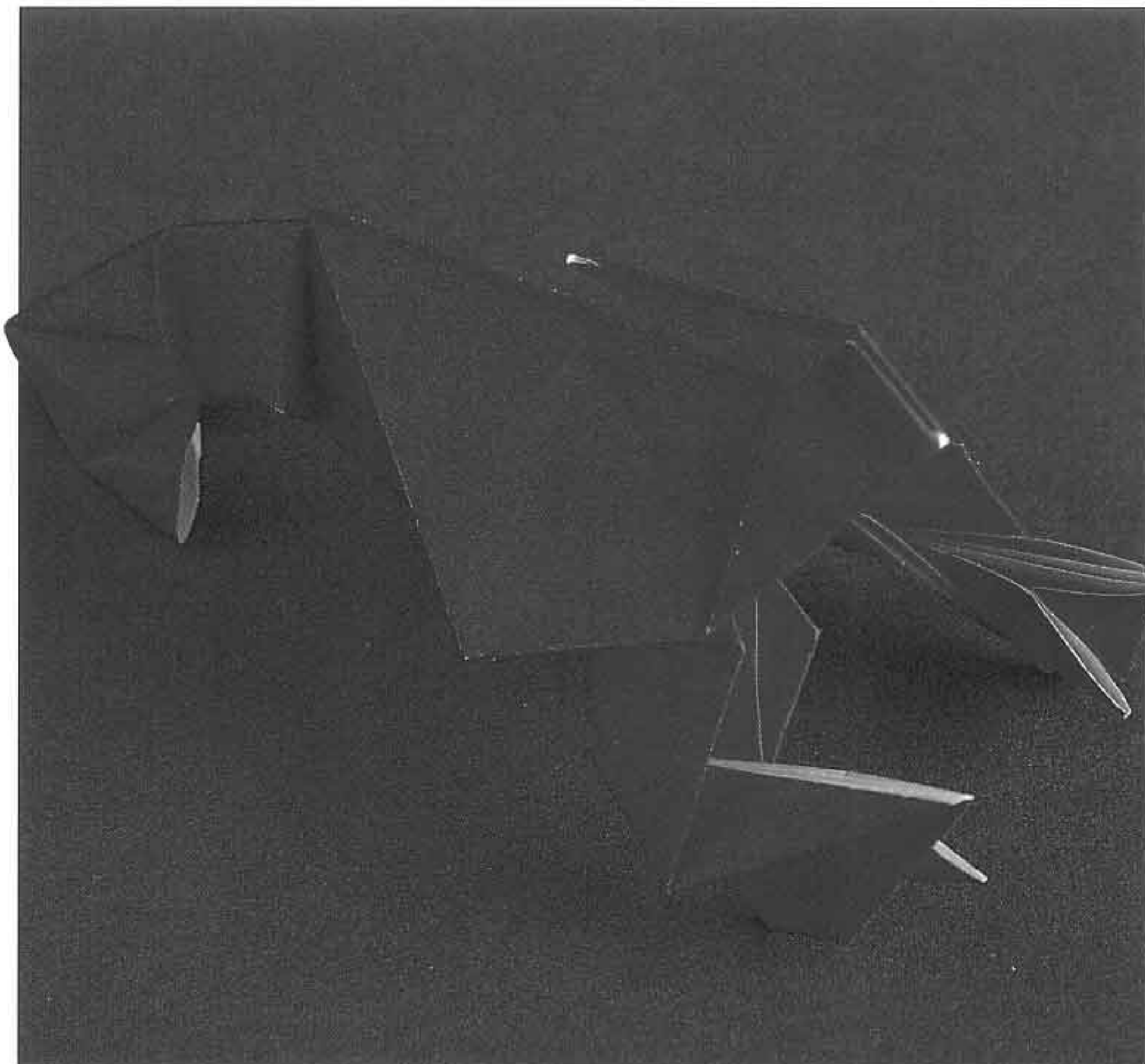

4 Fold corner B down to the intersection of the crease you just made with the diagonal BD.

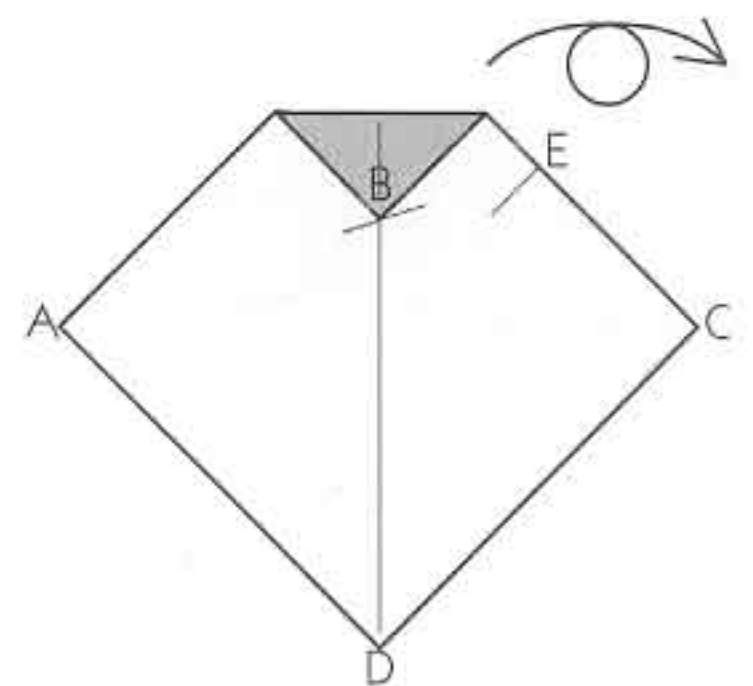

5 Turn the paper over.

crawfish

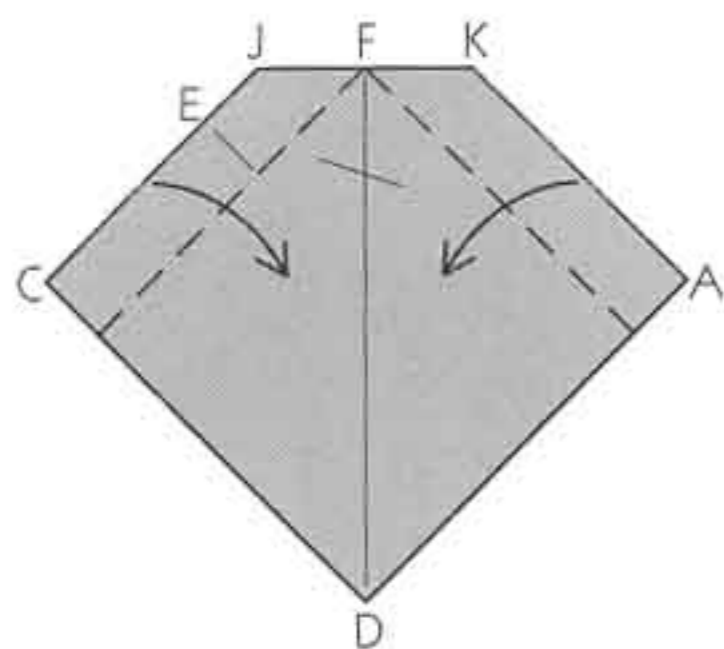

6 Fold edge CJ and AK inward.

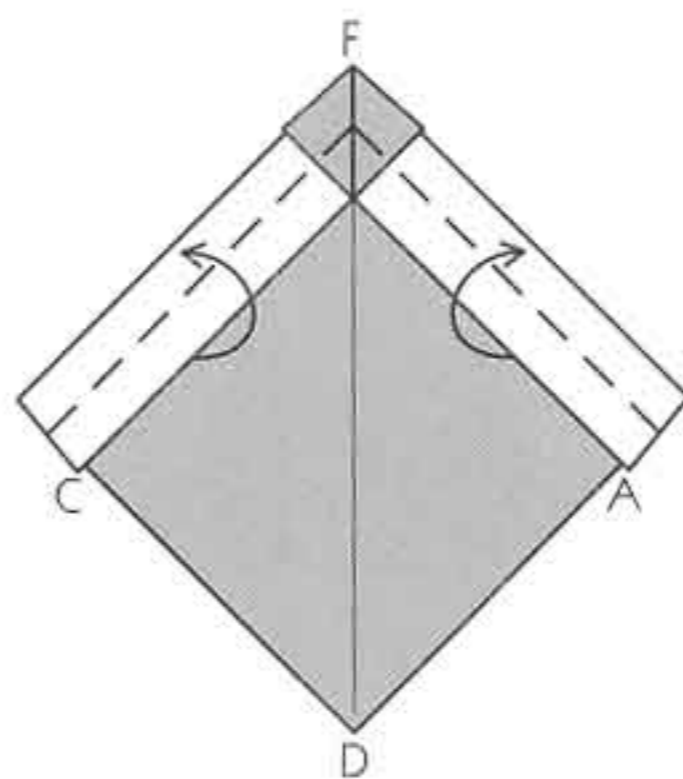

7 Fold the raw edge of the paper back up to lie along the folded edge on each side.

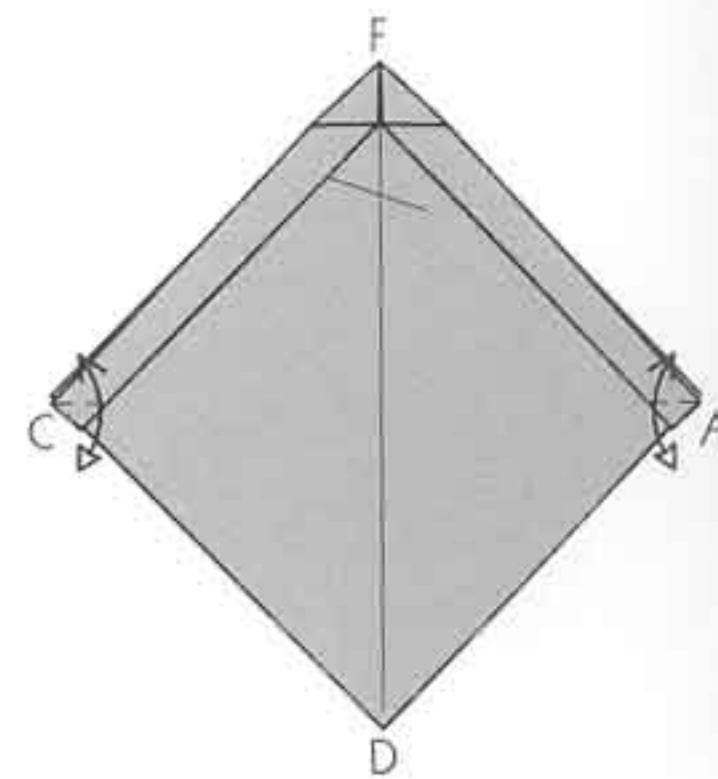

8 Fold the corner of the pleated flap to edge CF and unfold. Repeat on the right.

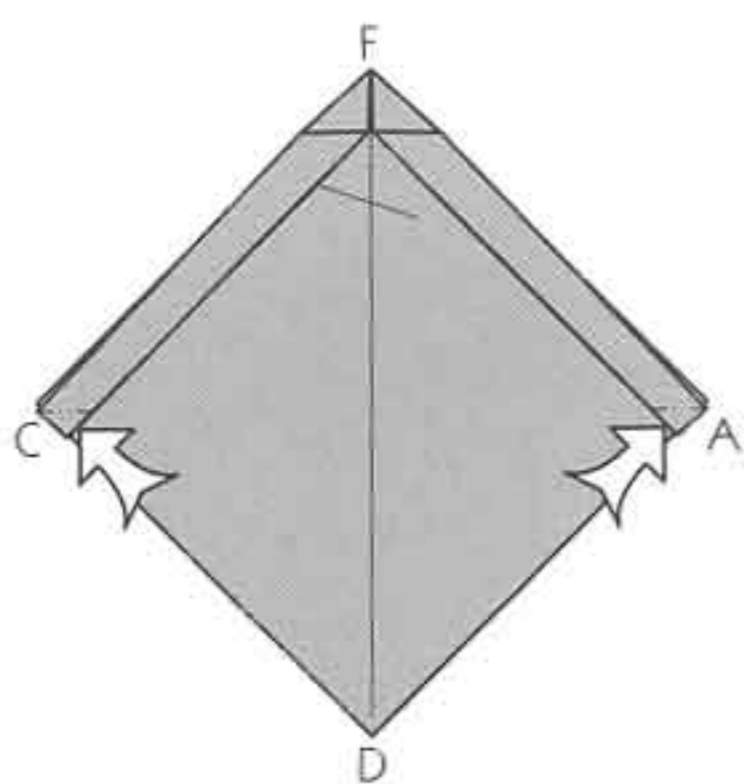

9 Reverse-fold the corners on the creases you just made.

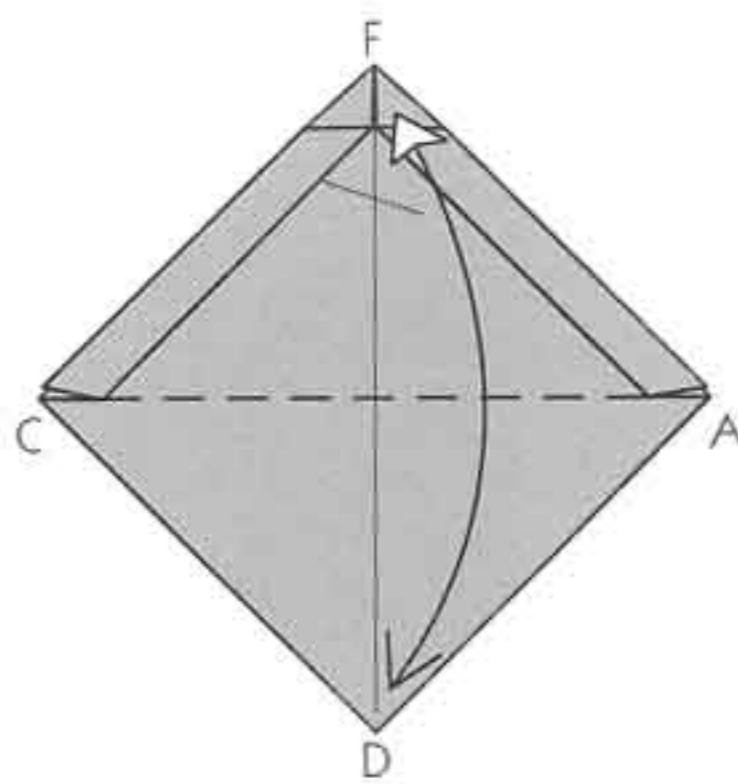

10 Fold corner F down to corner D and unfold. Turn the paper over.

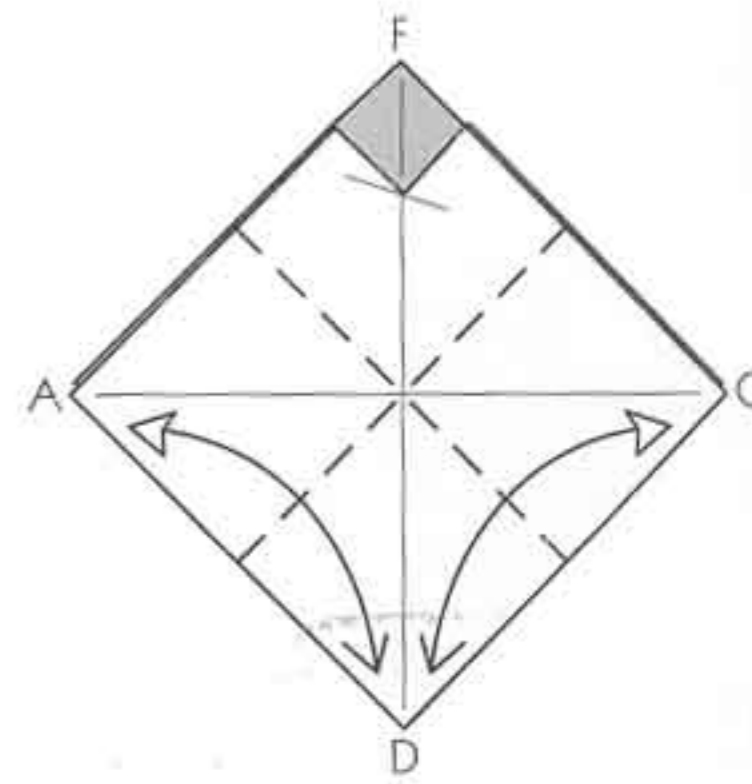

11 Fold edge AF to DC and unfold. Fold edge FC to AD and unfold.

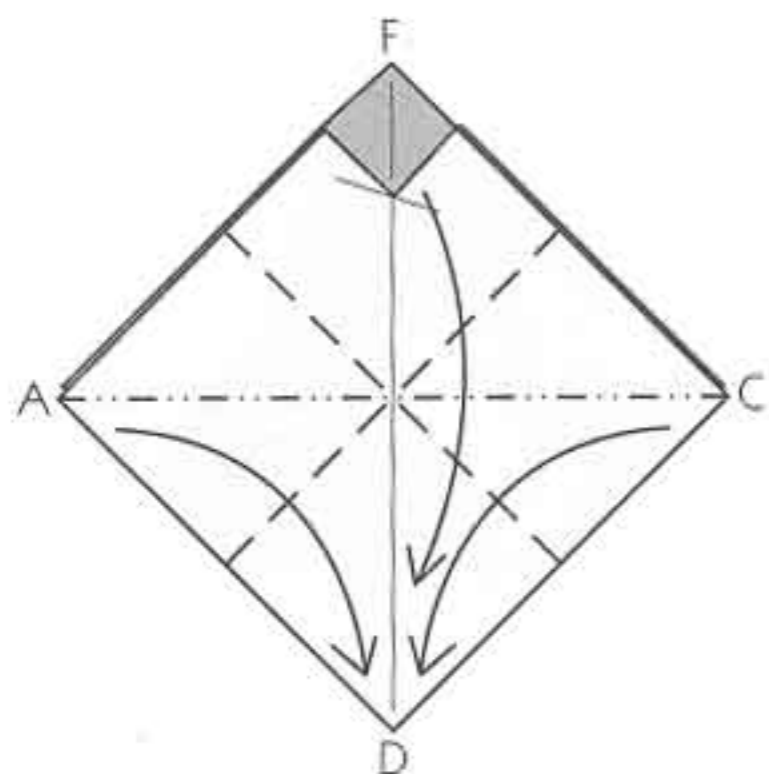

12 Bring corners A, F, and C together at the bottom at corner D.

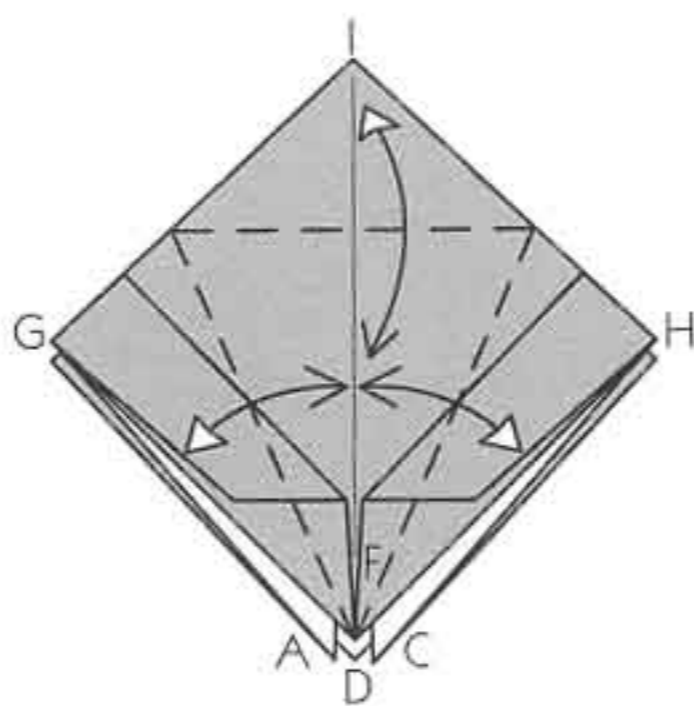

13 Fold edges GF and HF in to the center line and fold point I down over them; unfold. Repeat behind.

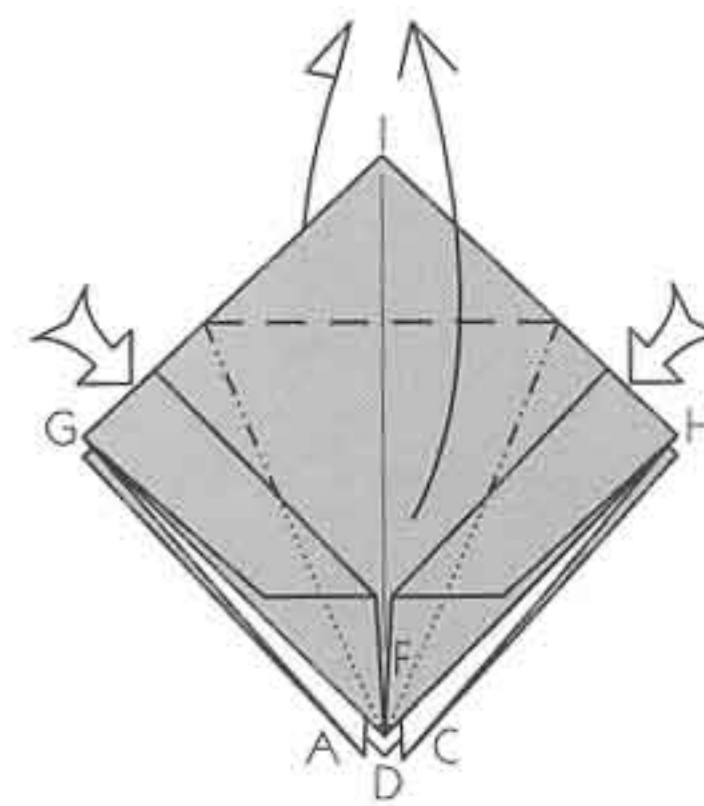

14 Petal-fold flap F upward, letting the small flaps at points A, D, and C swing out to the sides. Petal-fold flap D behind as well.

Louisiana bayou

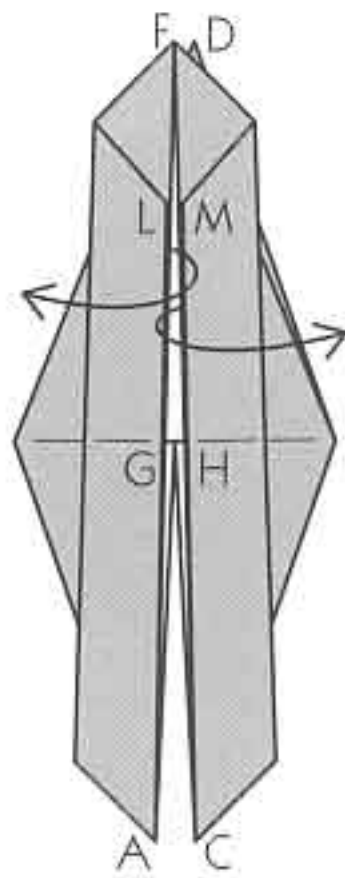

15 Open out edges L and M near the top of the model. This is easier if you allow points A and C to open slightly.

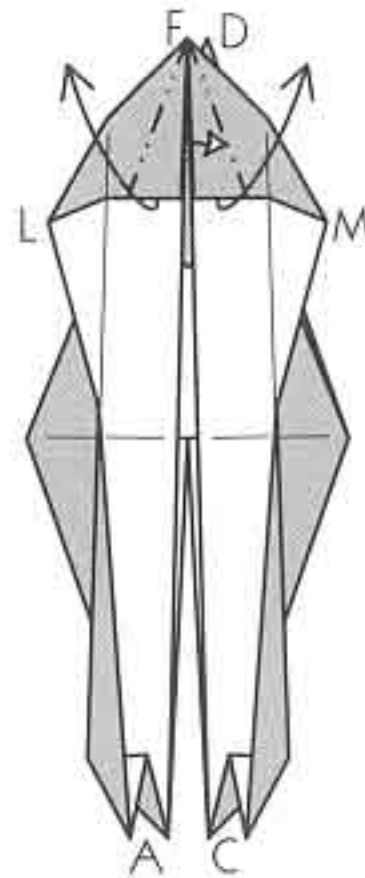

16 Pull the trapped paper out from flap F; spread the paper and flatten at the top. New creases will be formed along the top edge.

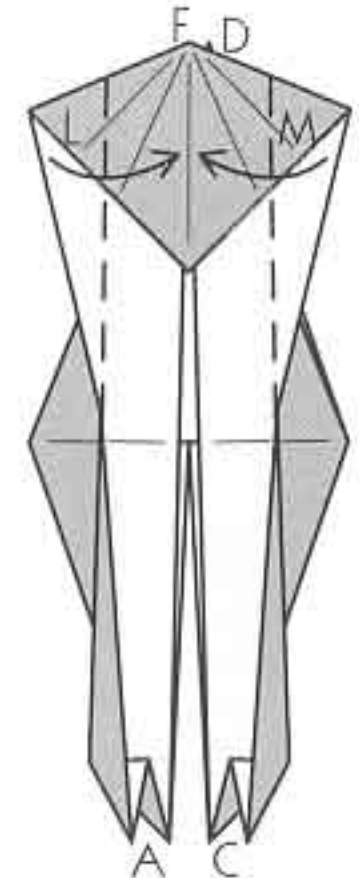

17 Close the model up again.

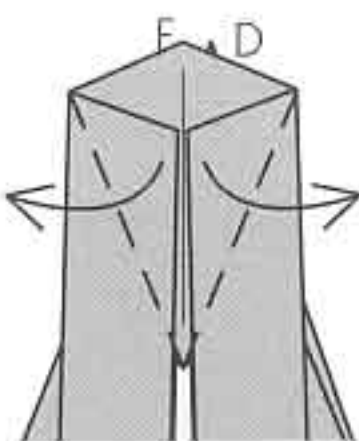

18 Fold the corners to the outside. The creases meet at the corner (inside).



19 Bring flap B to the front.

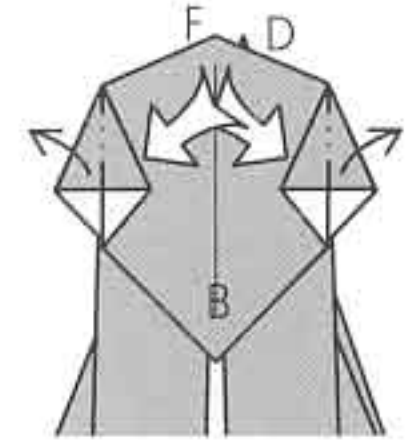

20 Squash-fold the two edges.

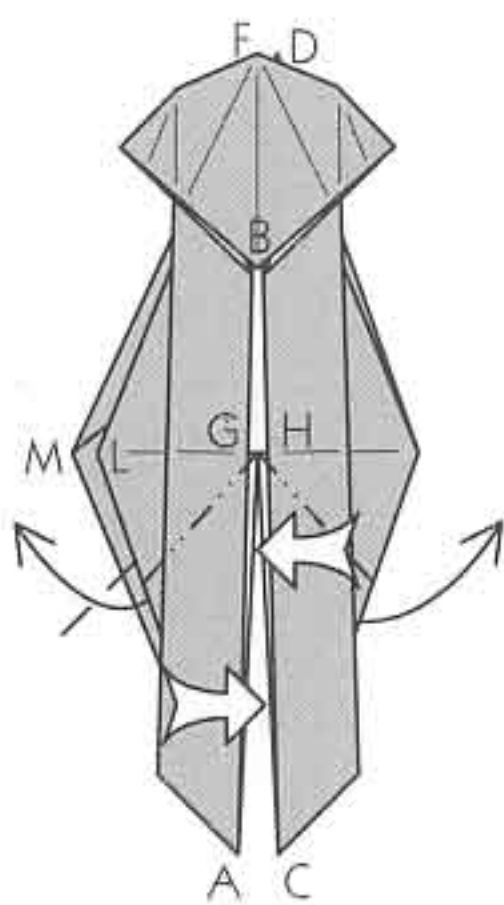

21 Reverse-fold flap A to the left. Note that the flap goes between layers L and M. Repeat on the right with flap C.

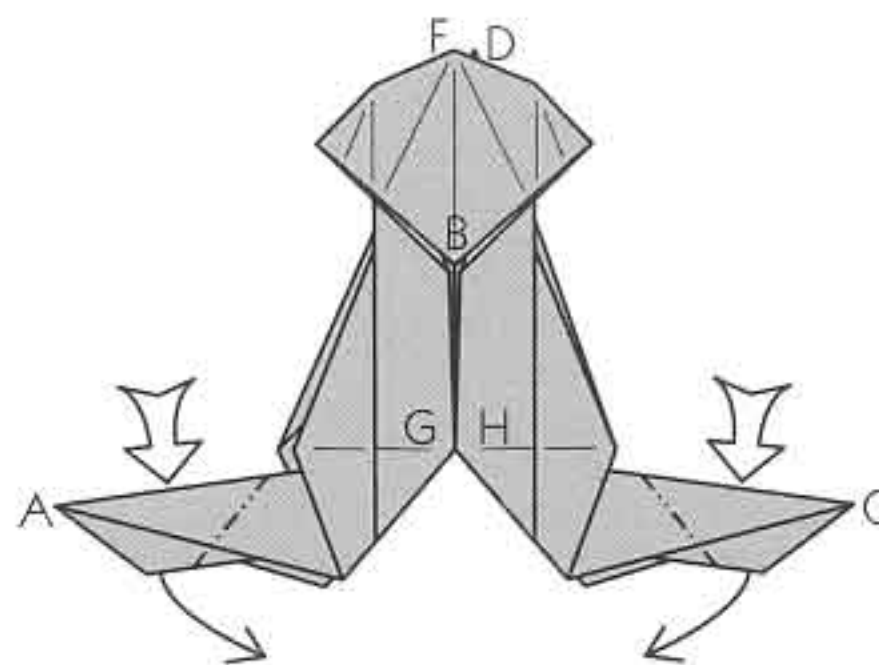

22 Reverse-fold flaps A and C downward, keeping the small, protruding flap to the front.

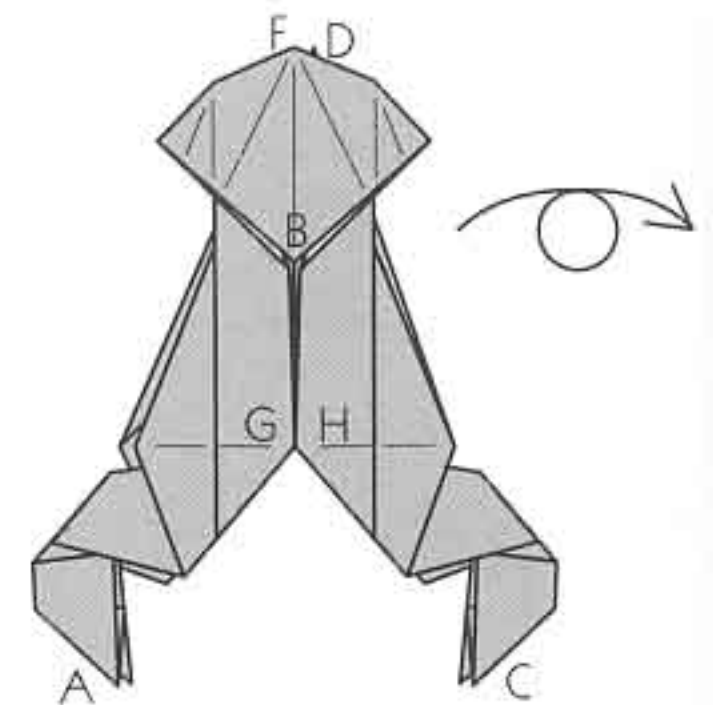

23 Turn the model over.

crawfish

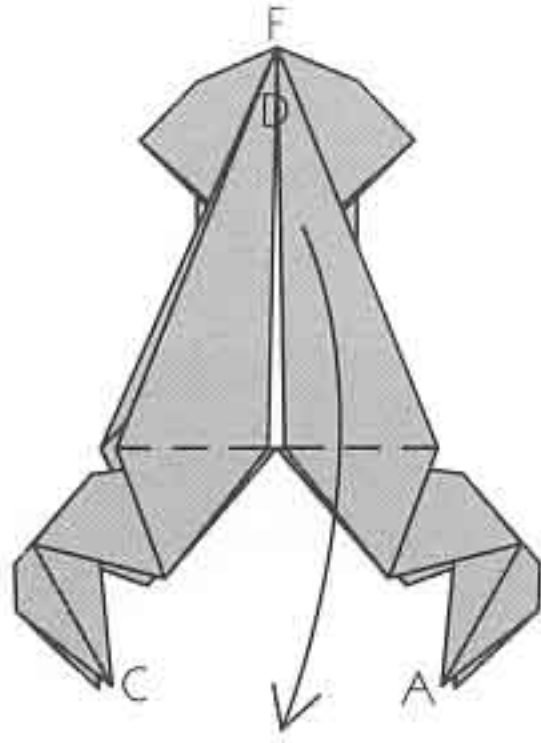

24 Fold flap D down.

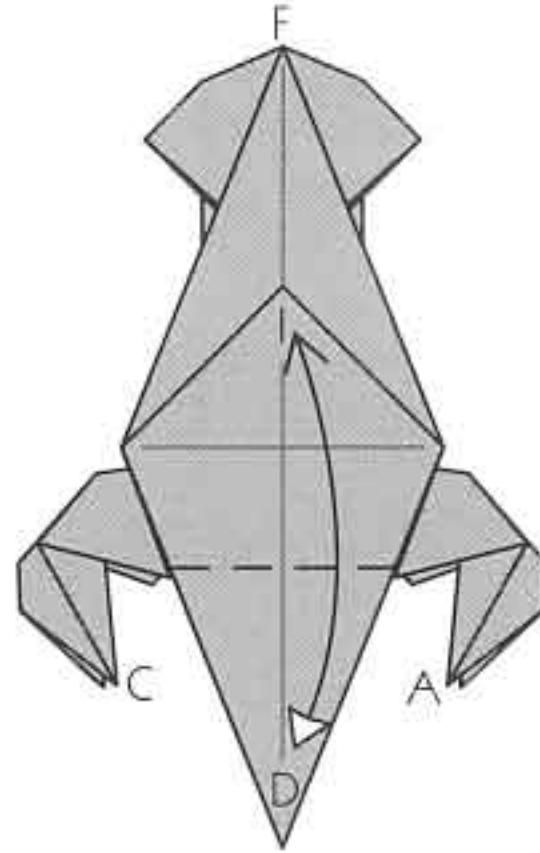

25 Fold flap D up to point I; crease and unfold.

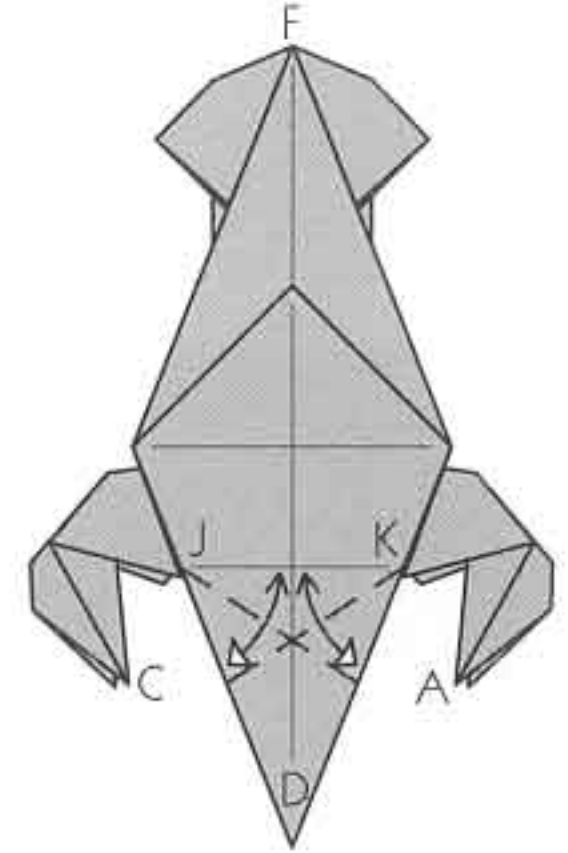

26 Fold edge JD up to the crease you just made (JK) and unfold. Repeat on the right with edge KD.

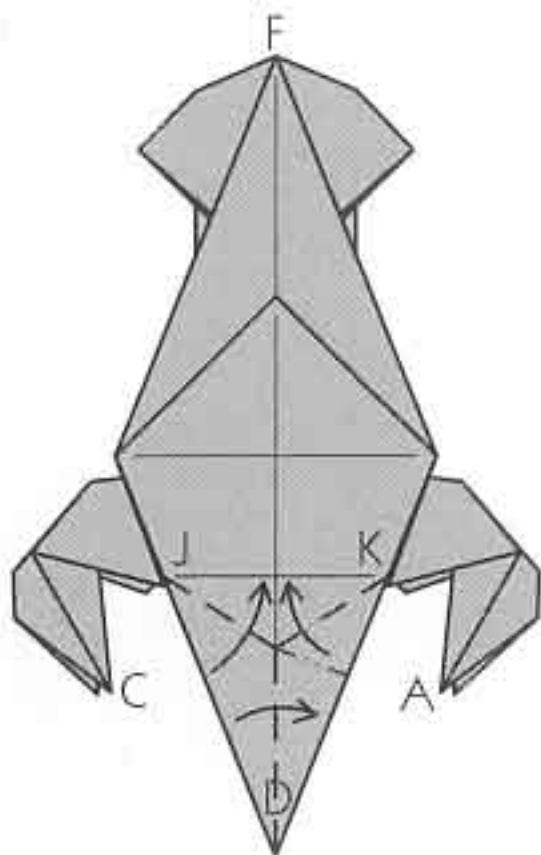

27 Fold a rabbit ear from corner D and fold it over to the right.

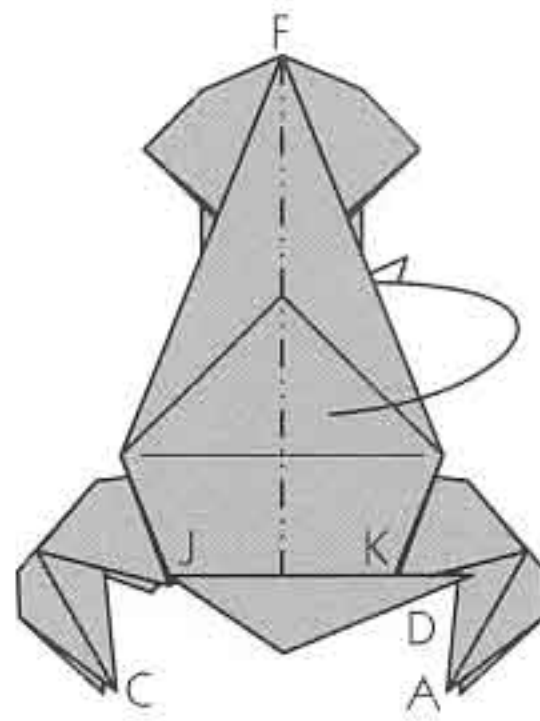

28 Mountain-fold the model in half, allowing point D to stand up from the body. Rotate the model 1/4 turn counterclockwise.

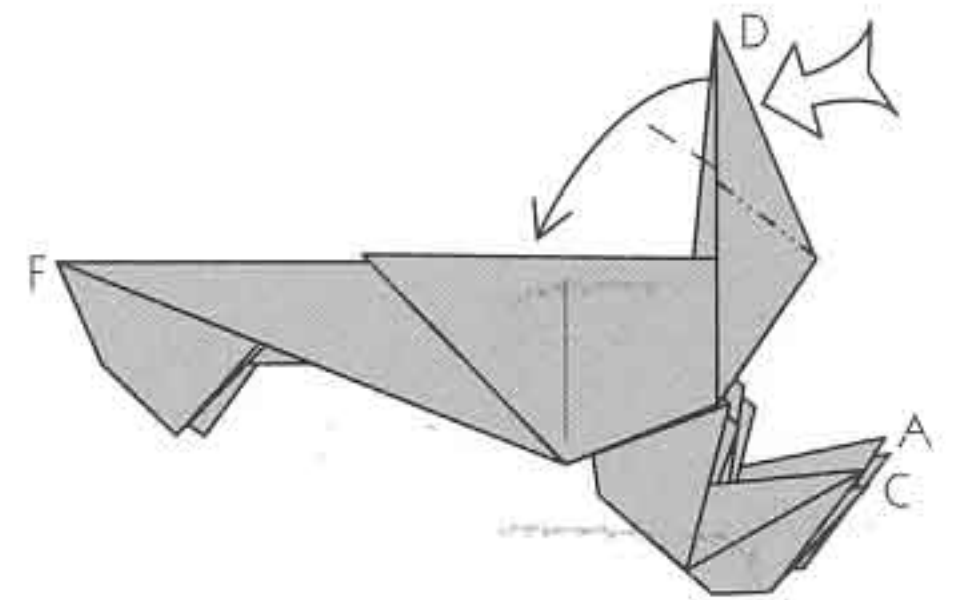

29 Reverse-fold corner D.

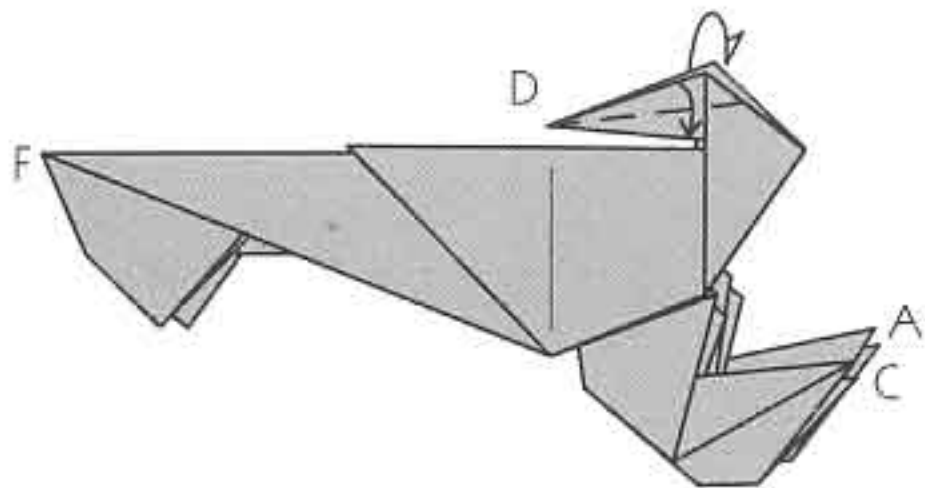

30 Narrow the antennae (point D) with valley folds.

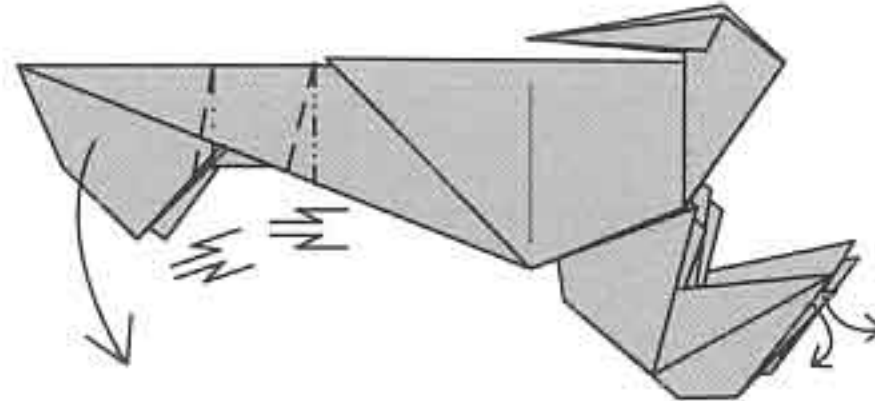

31 Crimp the tail downward. Open each claw.

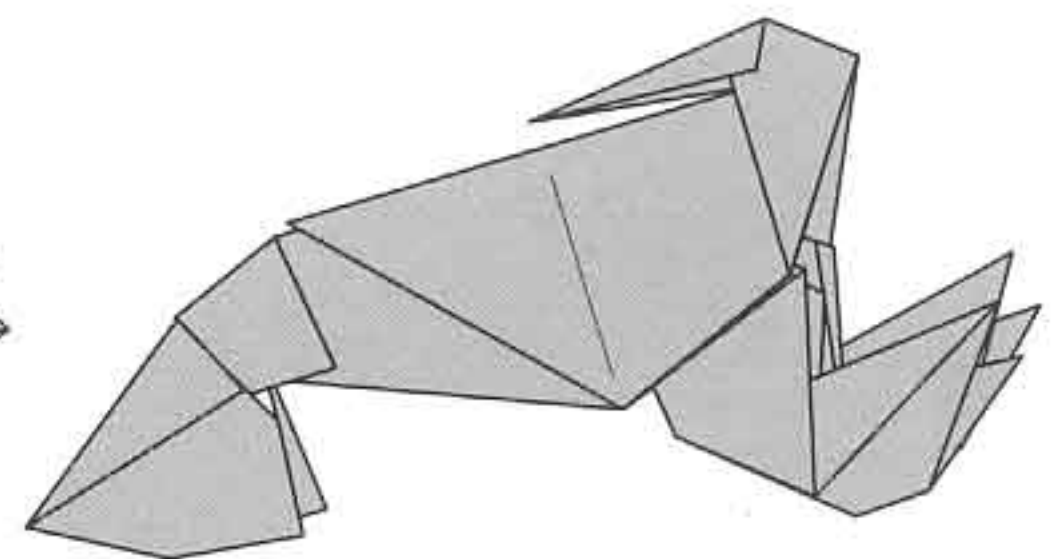

Finished Crawfish.

◆ turtle ◆

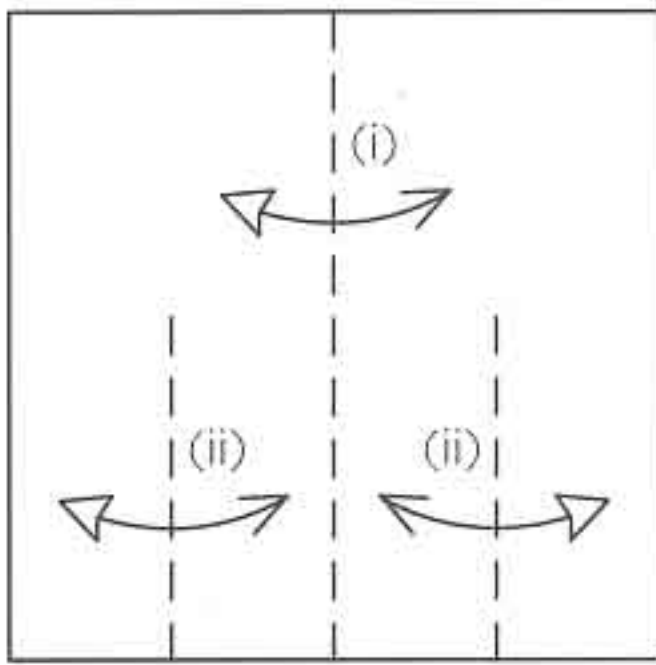
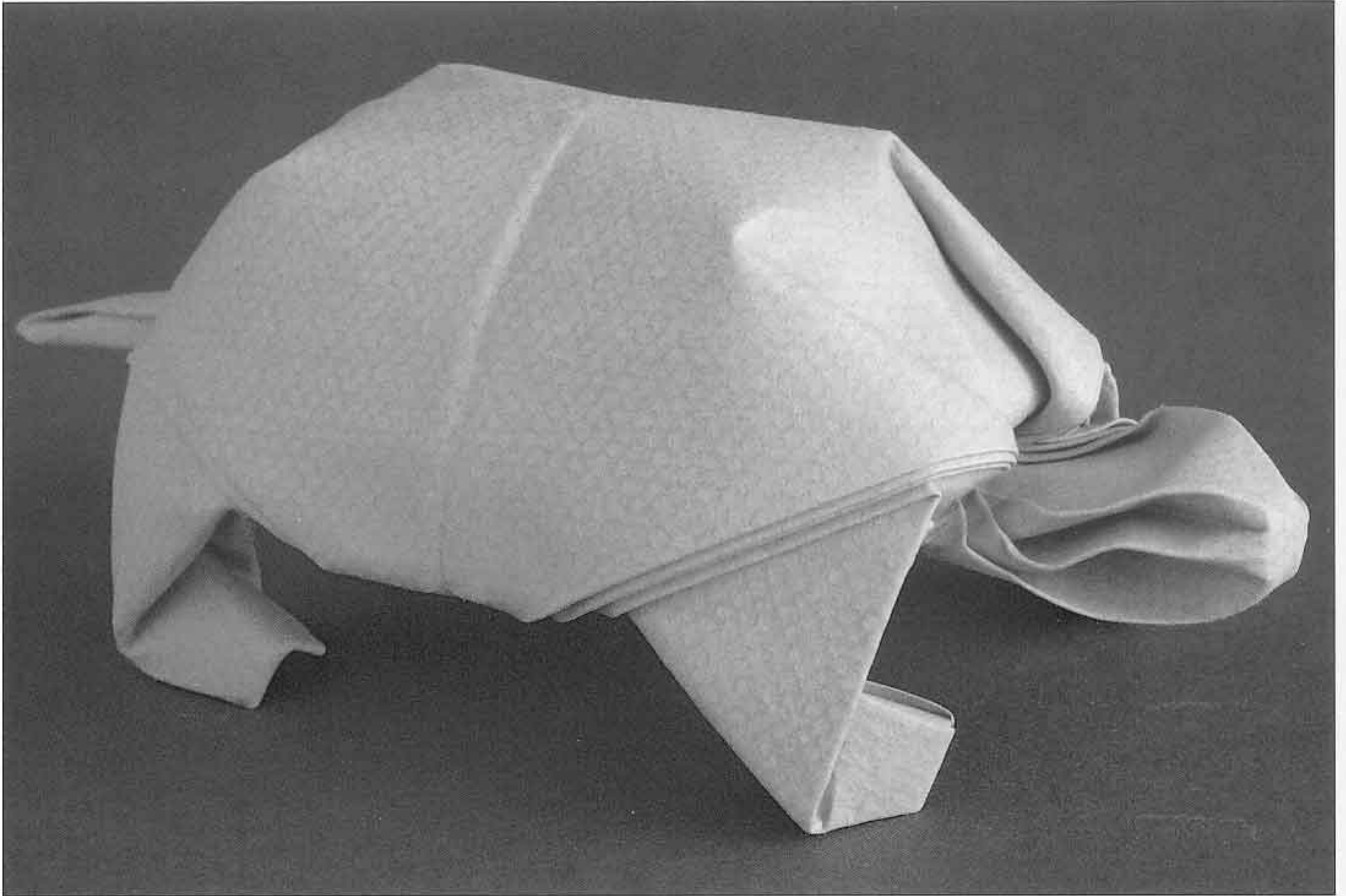

1 Begin with the white side up. Fold the paper in half vertically and unfold. Then fold the sides in to the center line, crease the lower part, and unfold.

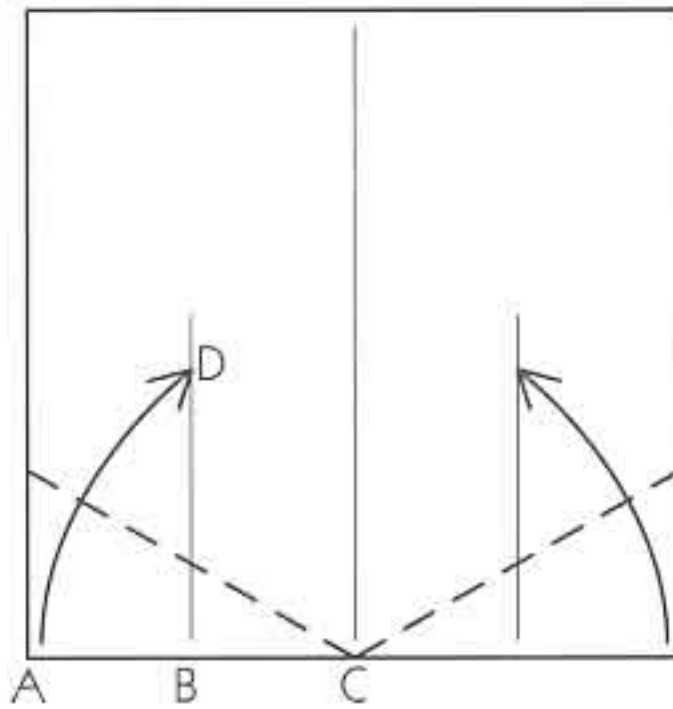

2 Fold corner A up to lie on line BD. Note that the crease hits the bottom edge of the paper at point C, the middle of the bottom edge. Repeat on the right side.

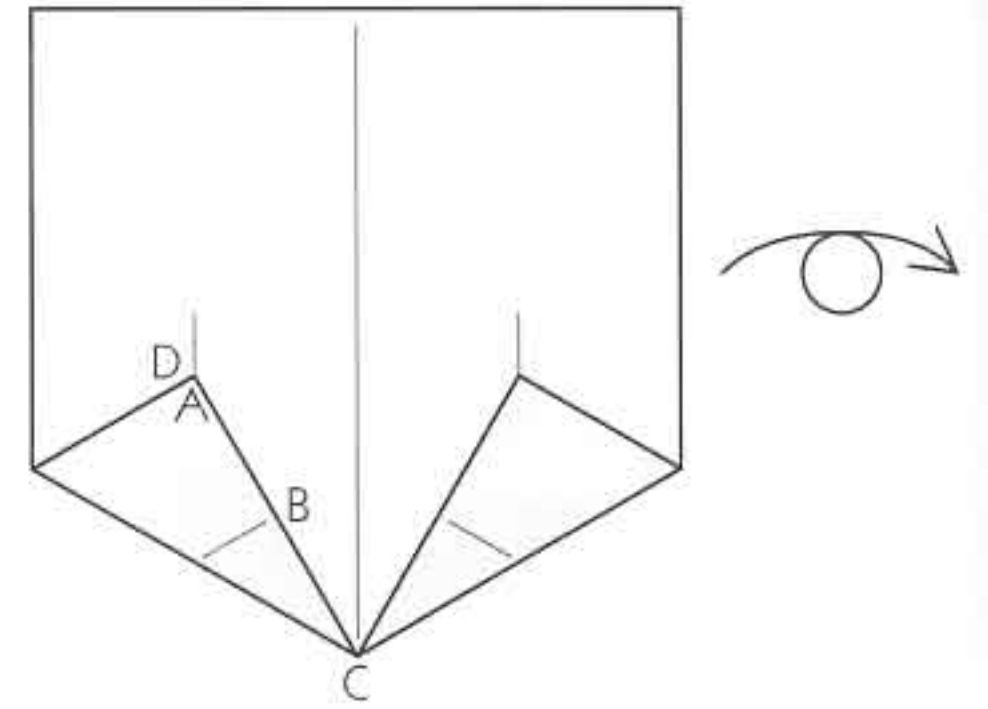

3 Turn the paper over.

turtle

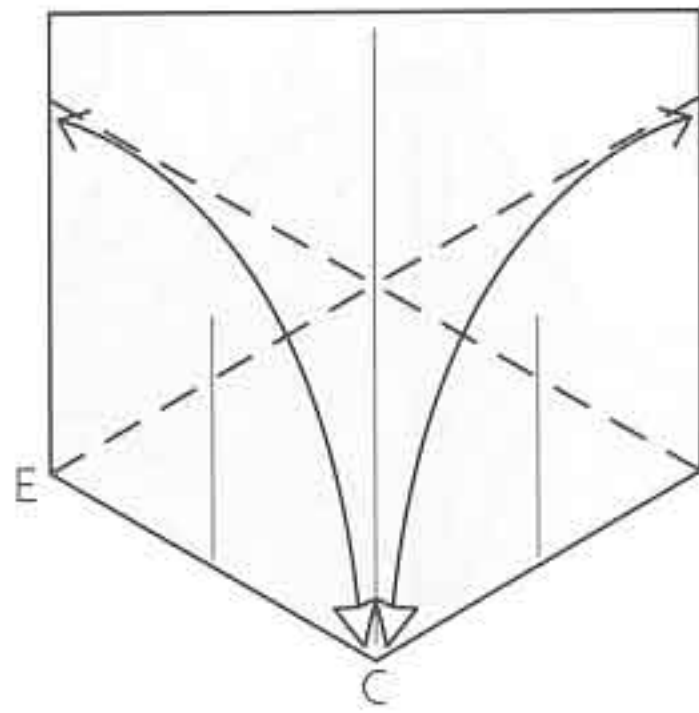

4 Fold corner C up to lie along the left edge—the crease runs through point E. Unfold. Repeat on the right.

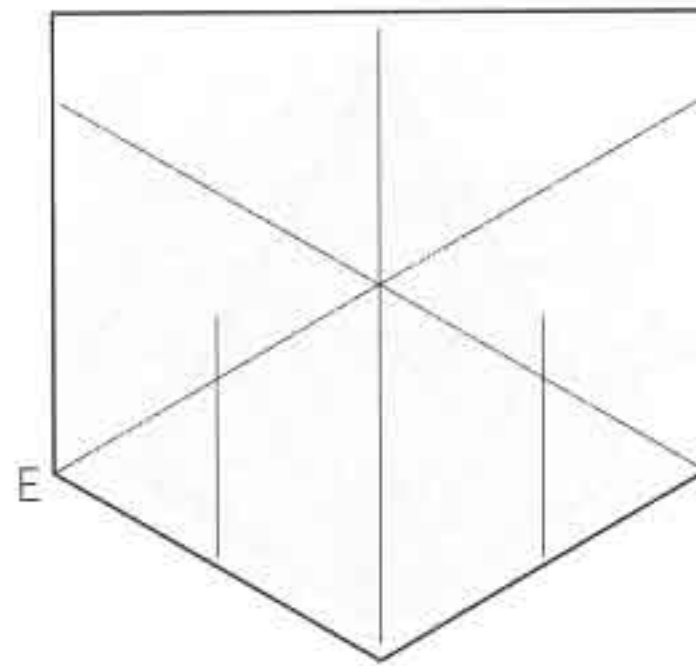

5 Turn over the paper.

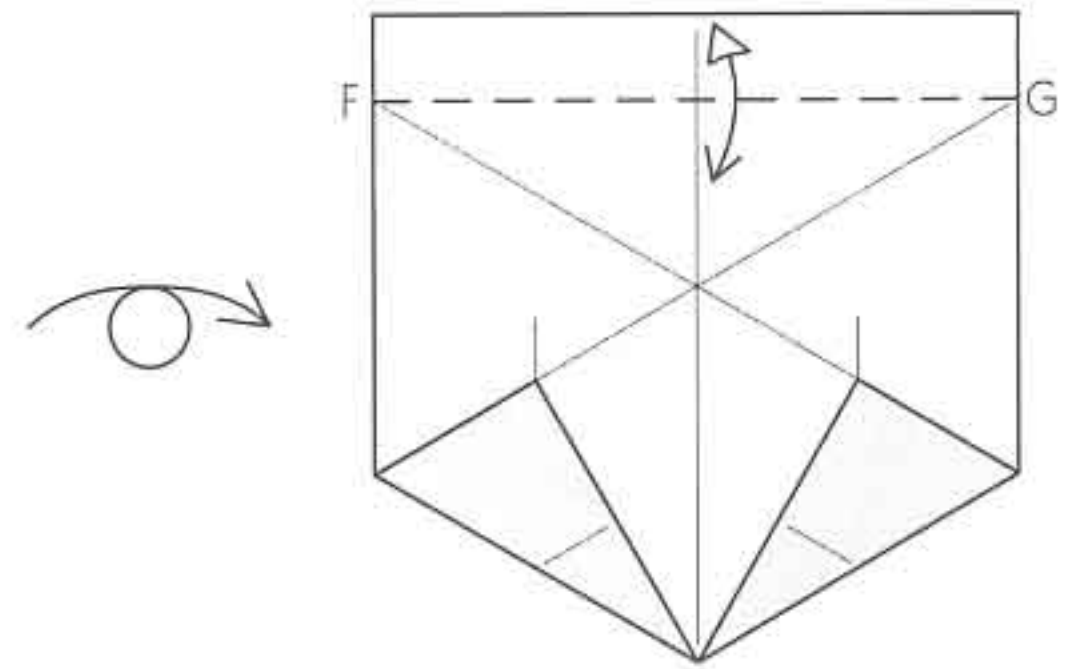

6 Fold down the top edge along a crease running between points F and G (where the two diagonal creases hit the edges). Unfold.

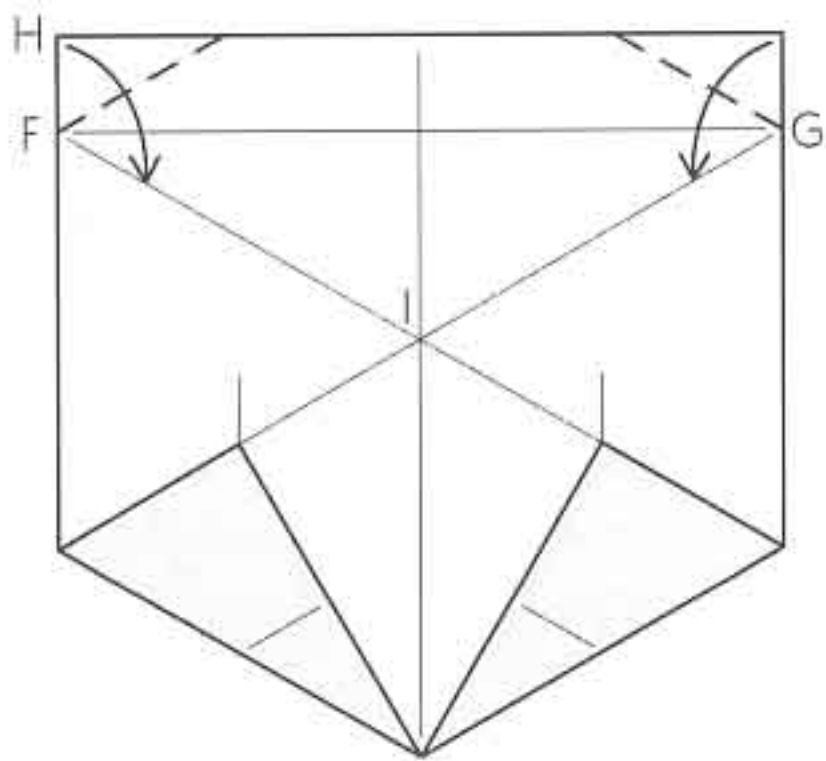

7 Fold down corner H to lie on line FI; the crease hits the edge at point F. Repeat on the right.

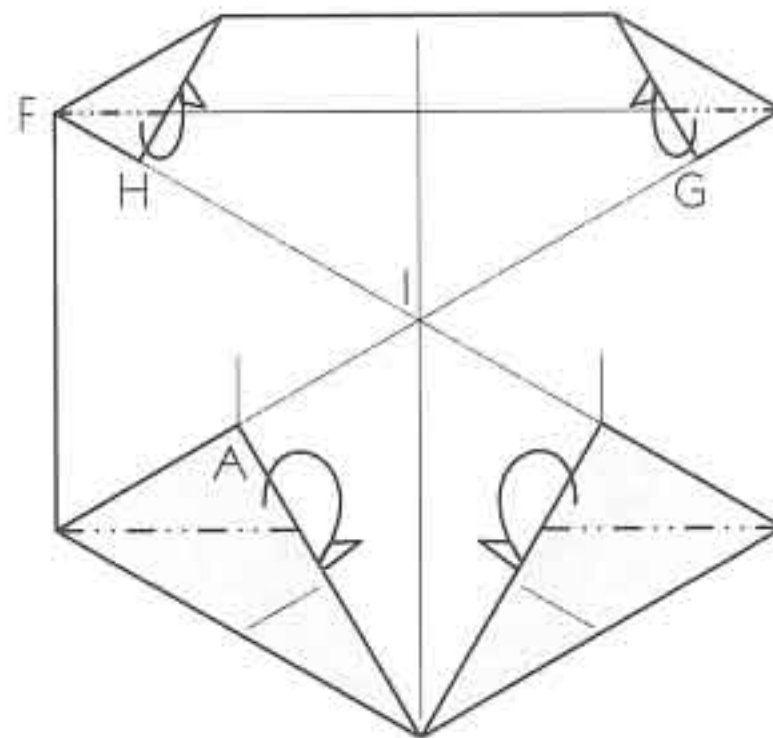

8 Fold corners A and H underneath. Repeat on the right. (This is easily done by unfolding flap A, making the fold, and refolding.)

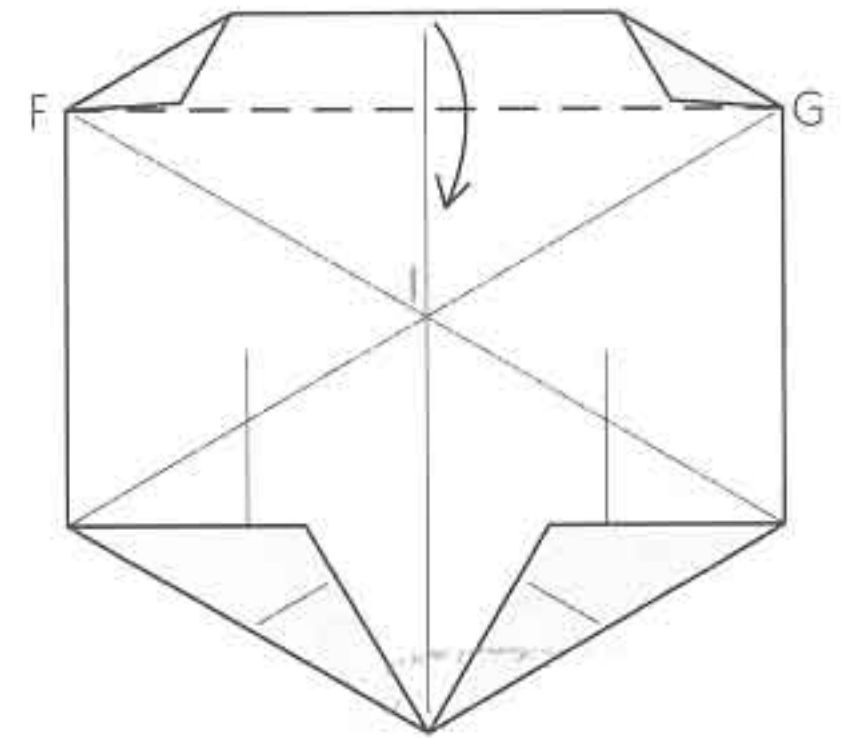

9 Fold the top edge down along the existing crease FG.

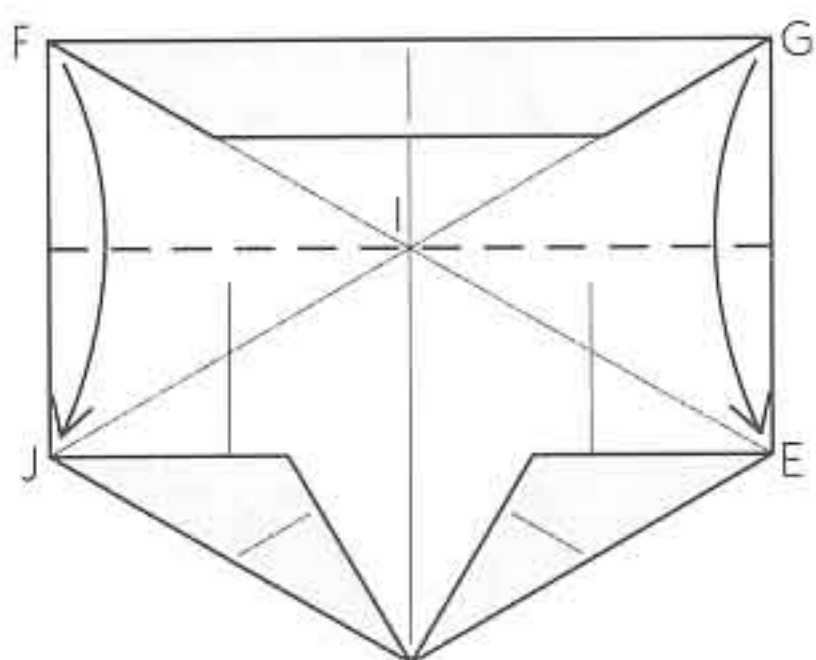

10 Fold down corners F and G to meet corners J and E, respectively.

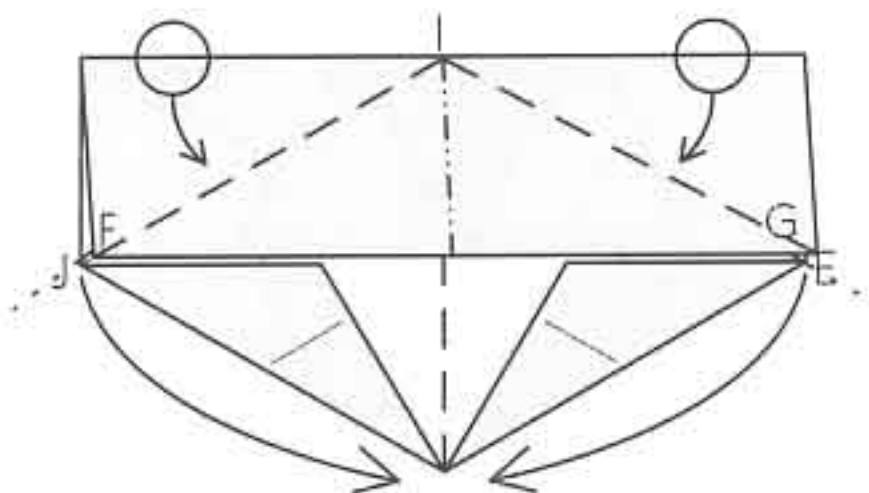

11 Bring corners J, F, G, and E together at the bottom of the model (it will not lie flat).

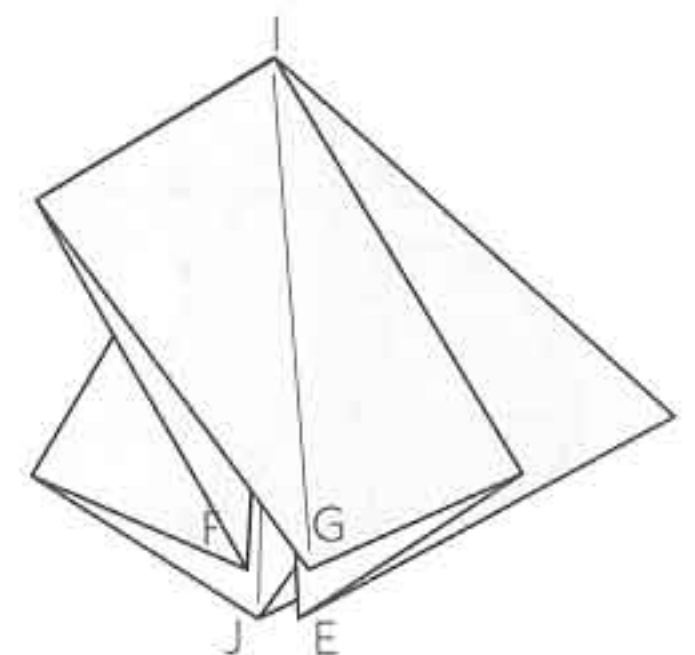

12 Flatten the paper out. Note that the top flap swings to the left and the rear flap swings to the right.

Louisiana bayou

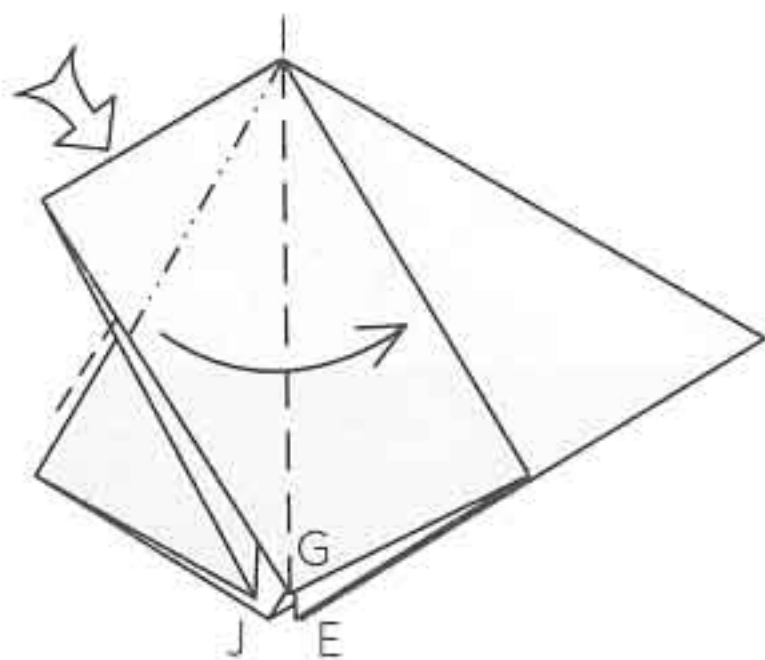

13 Squash-fold the top flap.

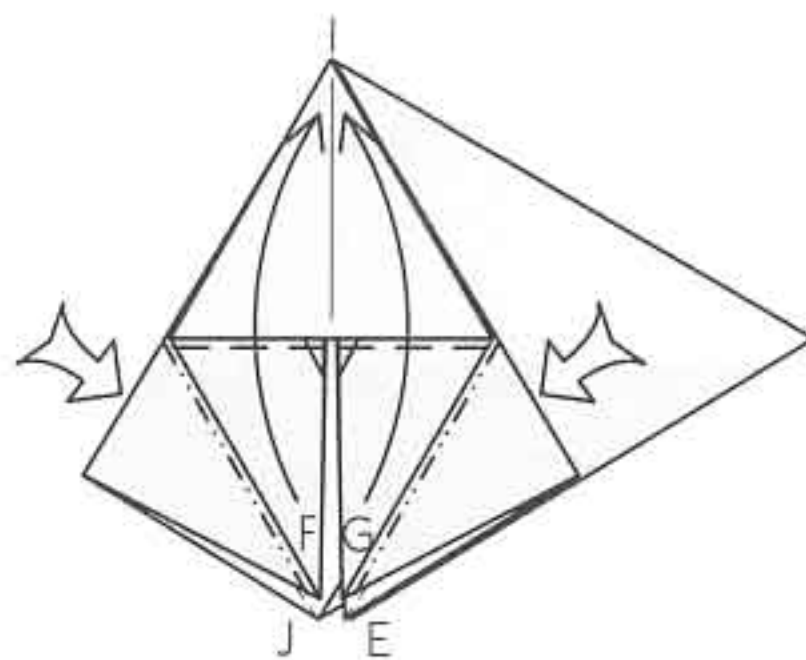

14 Squash-fold each side. Corners F and G get folded up to point I.

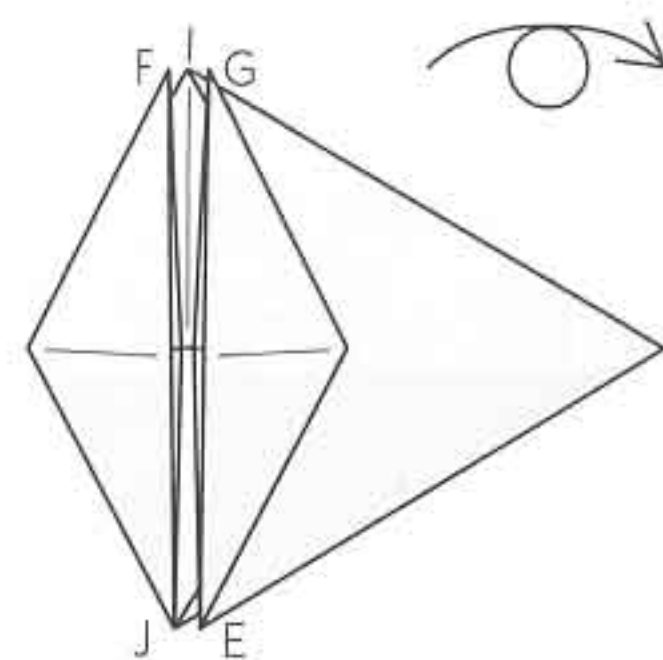

15 Turn the model over from side to side.

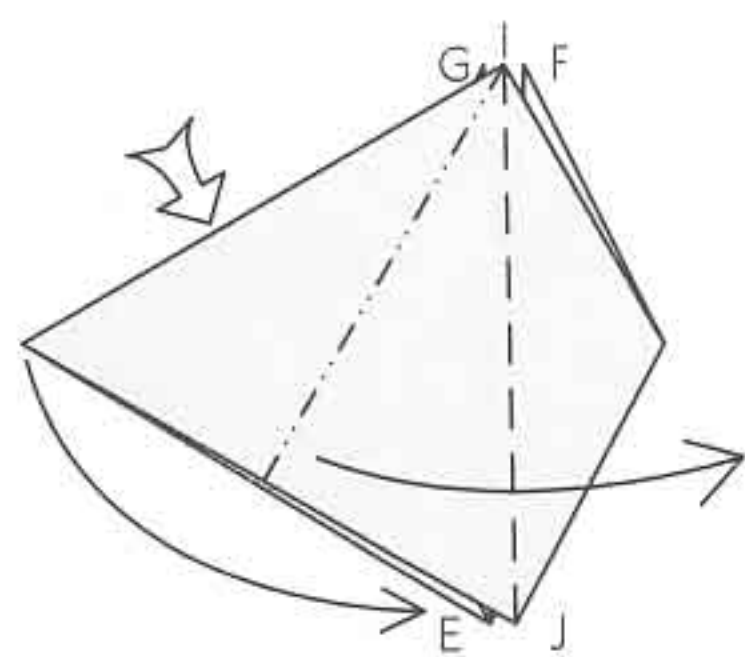

16 Squash-fold the large point.

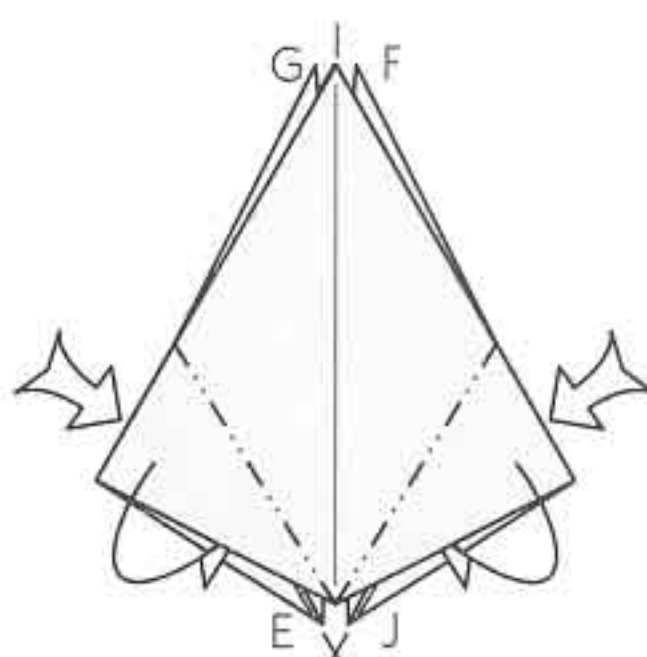

17 Reverse-fold the side corners.

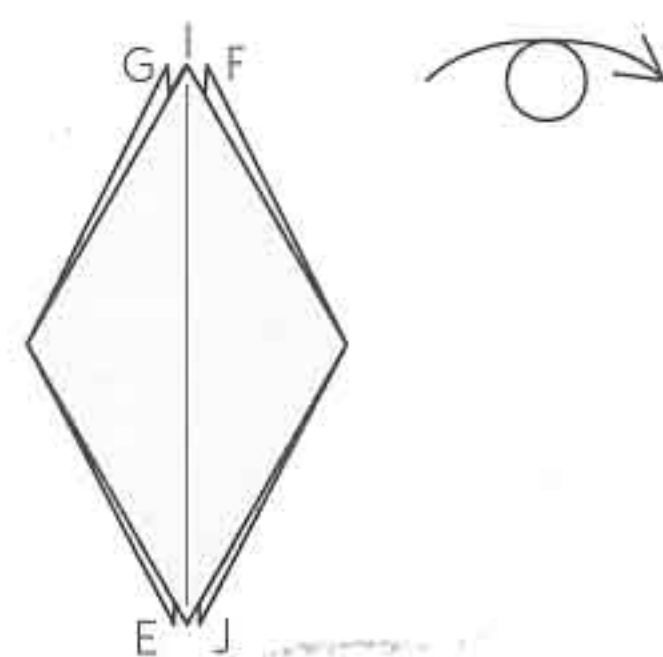

18 Turn the model over from side to side.

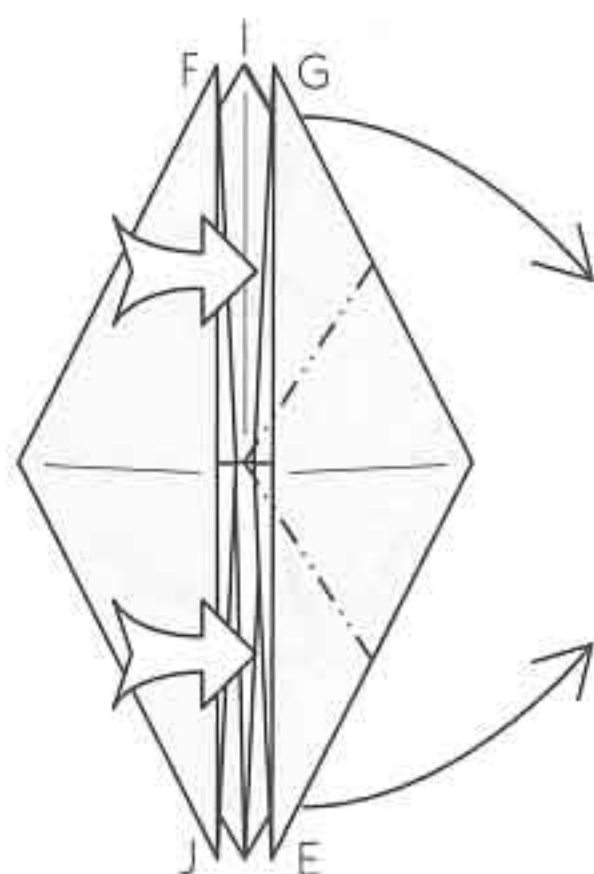

19 Reverse-fold two points to the right.

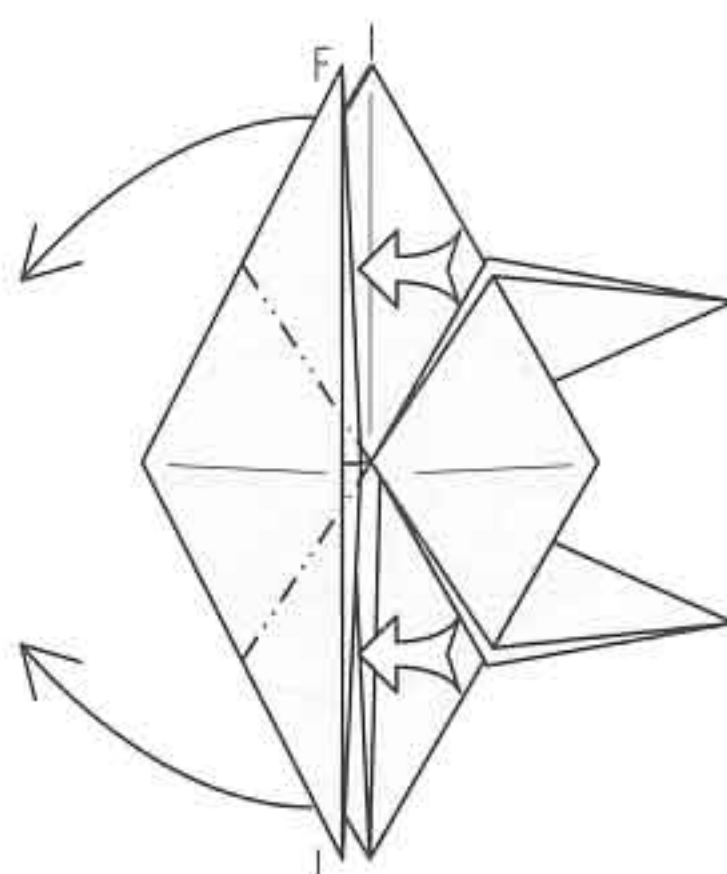

20 Repeat on the left.

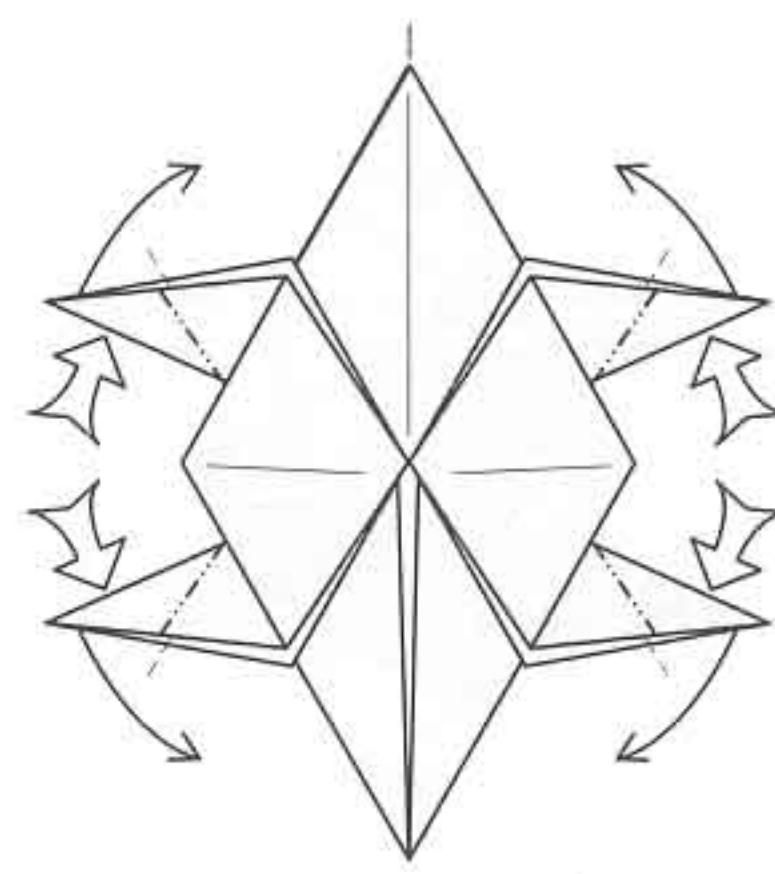

21 Reverse-fold all four points.

turtle

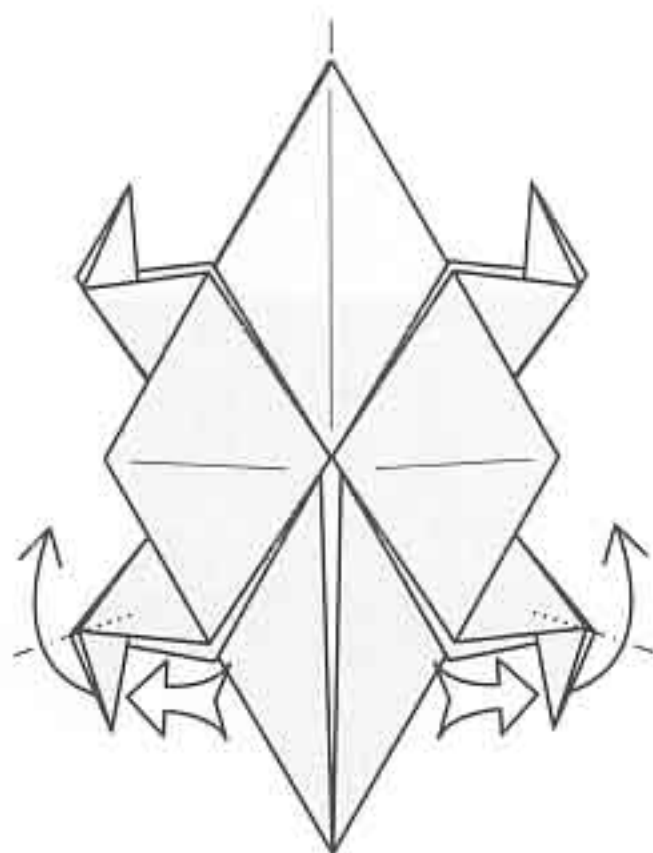

22 Reverse-fold the bottom pair of points upward. Be sure that point 1 (the thick point) is at the top.

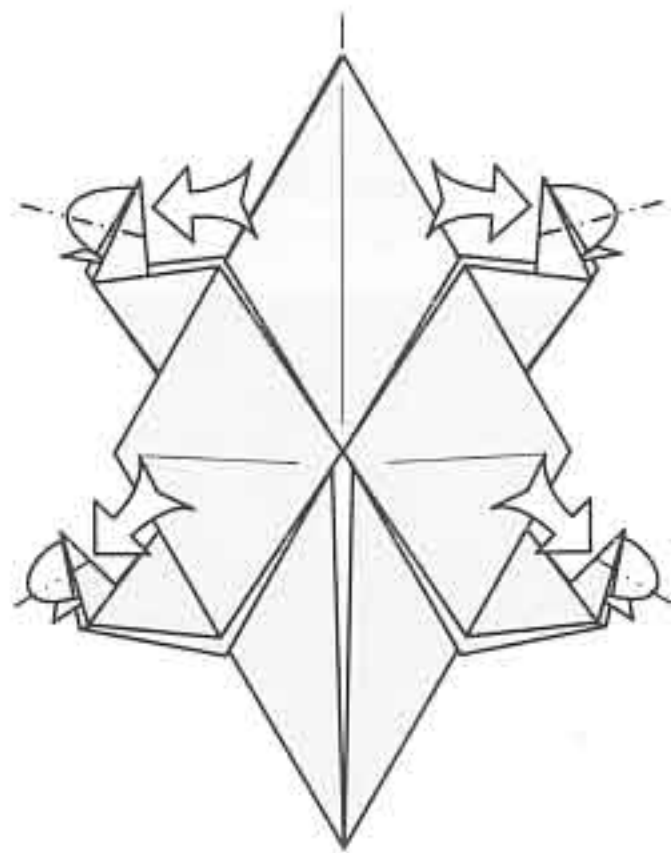

23 Reverse-fold the tips of all four points. Turn the model over.

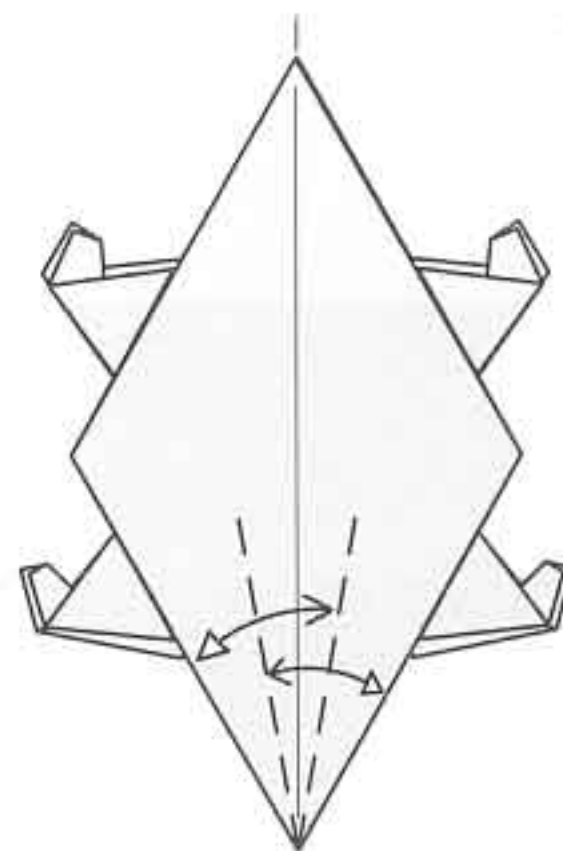

24 Fold the bottom point (the tail) in thirds and unfold. You don't need to make the creases run all the way up.

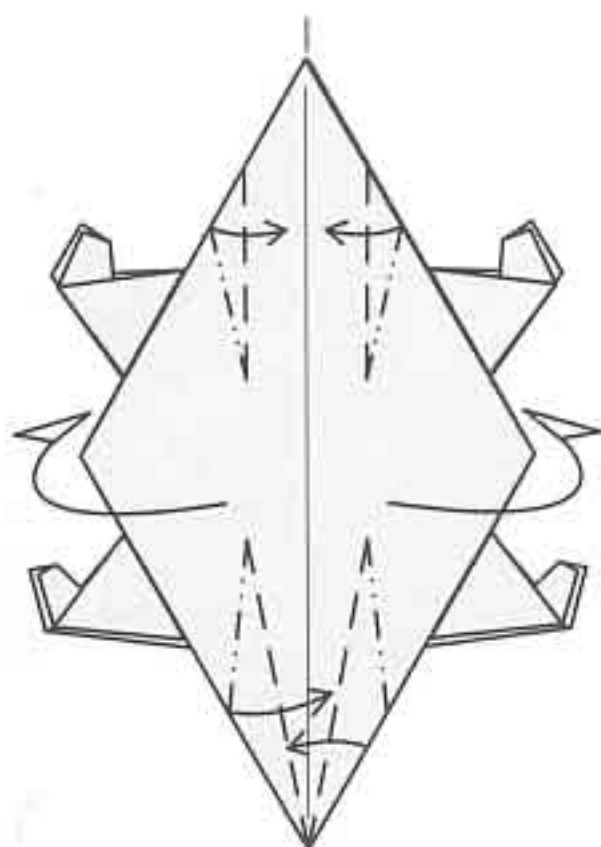

25 Curve the sides of the body away from you; at the same time, crimp the top and bottom of the model. On the bottom, the two edges overlap one another. On the top, they meet in the middle. The shell will bulge upward in the middle.

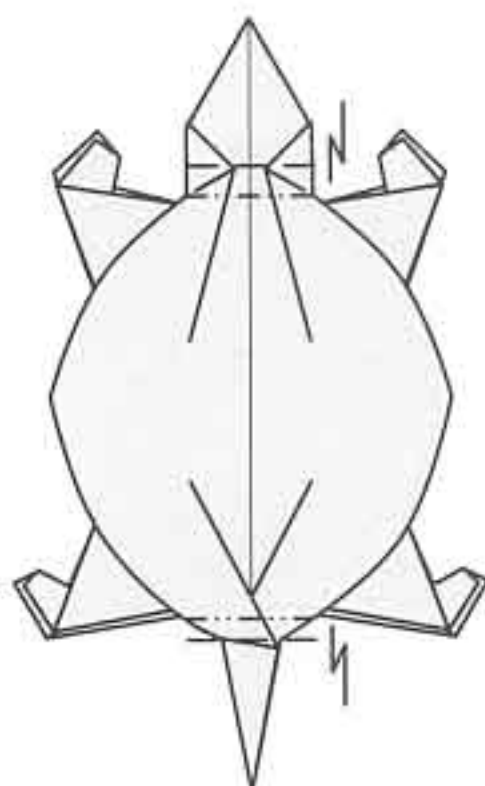

26 Pleat the neck and tail. This locks the crimps from step 25 in place.

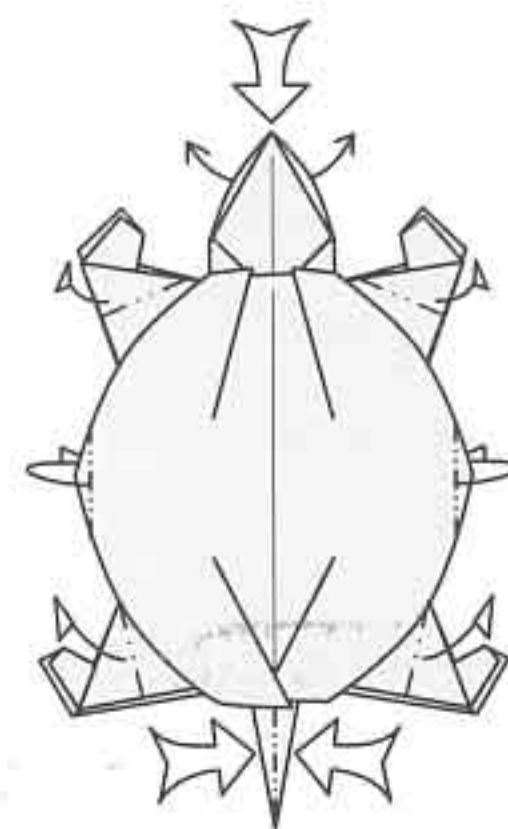

27 Final shaping. Pull out the middle layers of the head and puff it up slightly. Fold the feet down. Pinch the tail in half. Mountain-fold the sides of the shell and round it out.

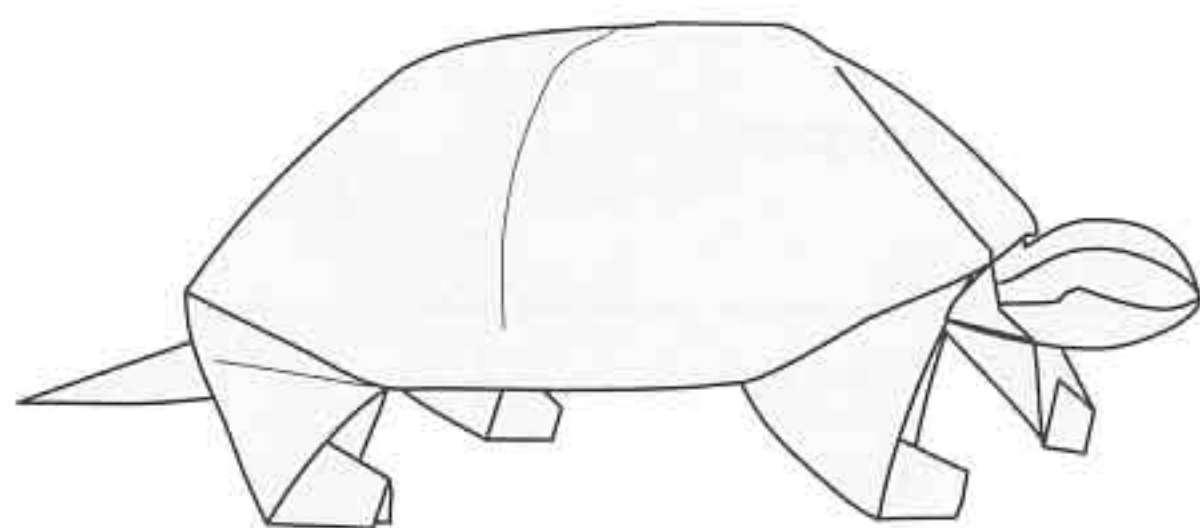

Finished Turtle.

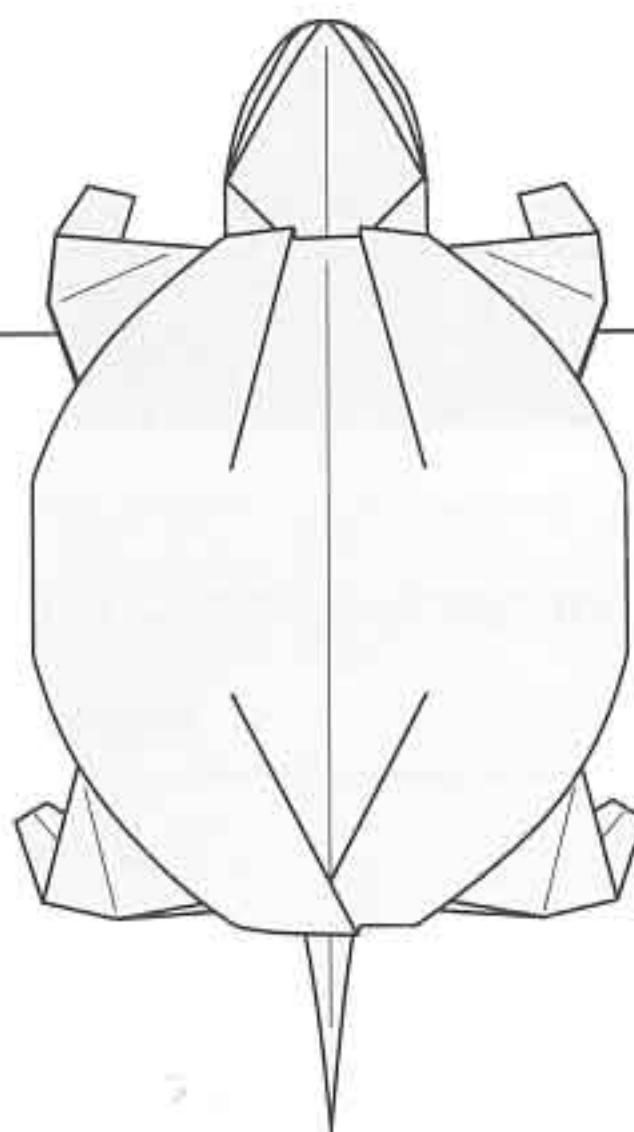

◆ ocean ◆

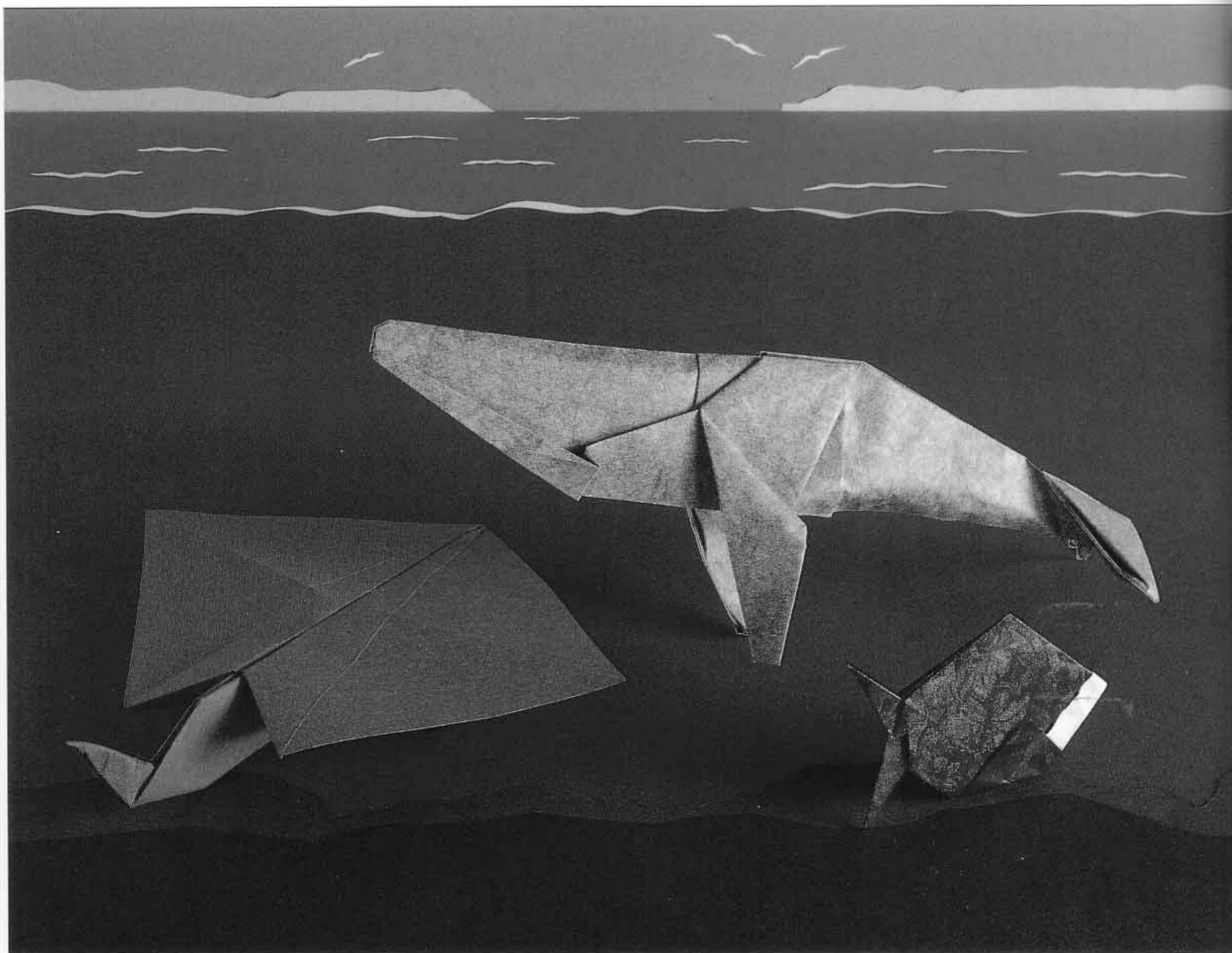

For this project, you will fold the following models:

Name	Page	Rating	Paper requirements
Fish	61	Easy	4 in (10 cm) square of blue paper
Skate	63	Low Intermediate	10 in (25 cm) square of gray paper
Gray Whale	65	High Intermediate	20 in (50 cm) square of gray paper

◆ fish ◆

designed by Karen Reeds

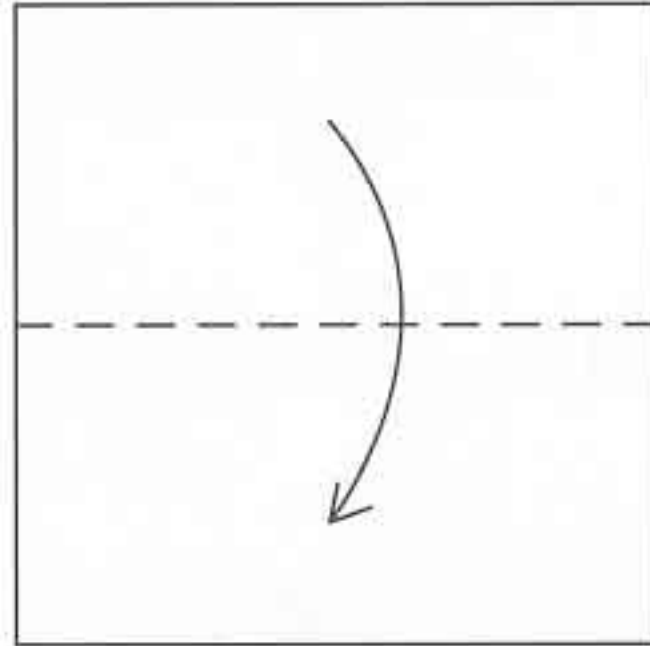
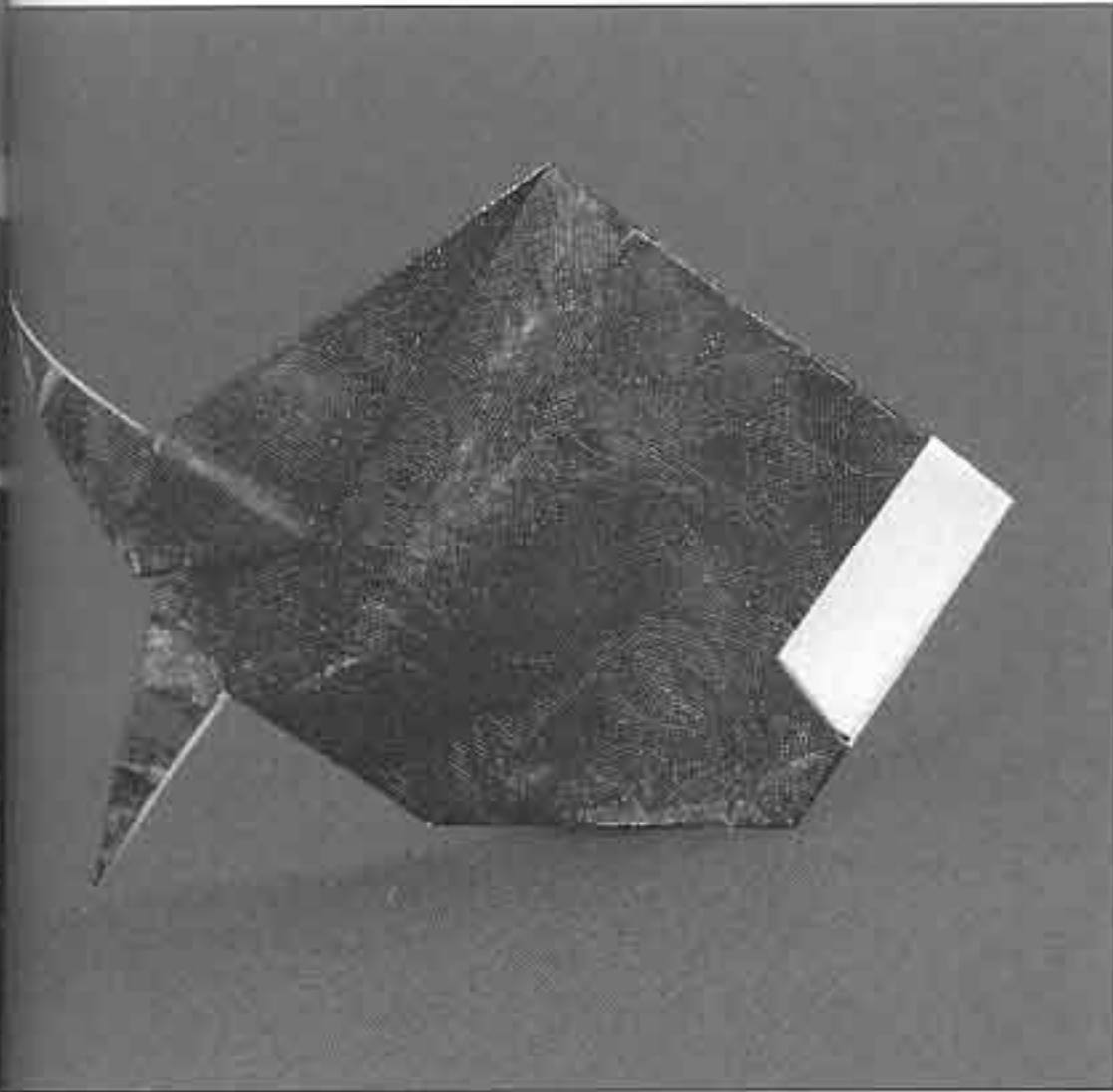

1 Begin with the white side up. Fold the paper in half from top to bottom.

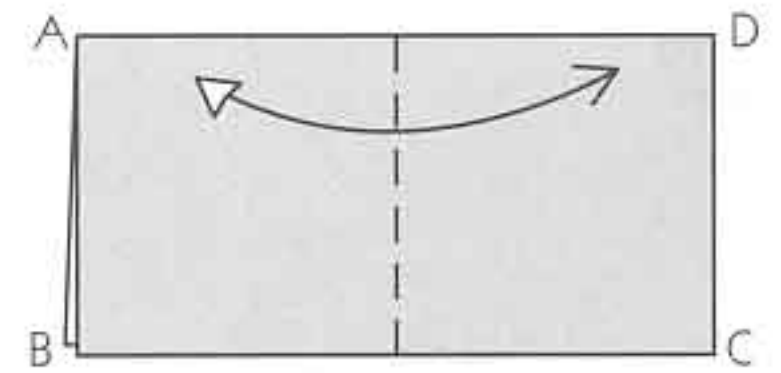

2 Fold edge AB over to edge DC and unfold.

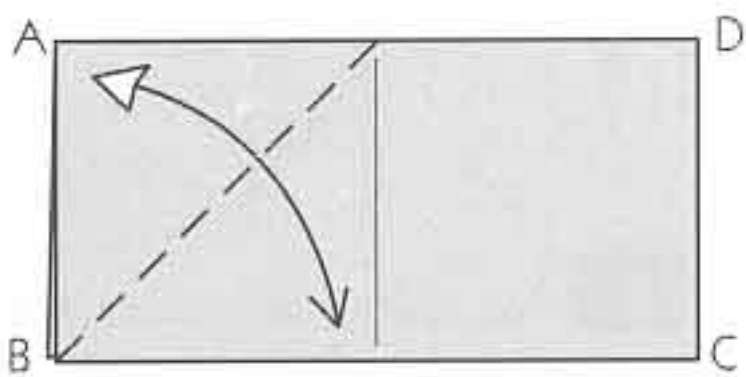

3 Fold down edge AB to edge BC and unfold.

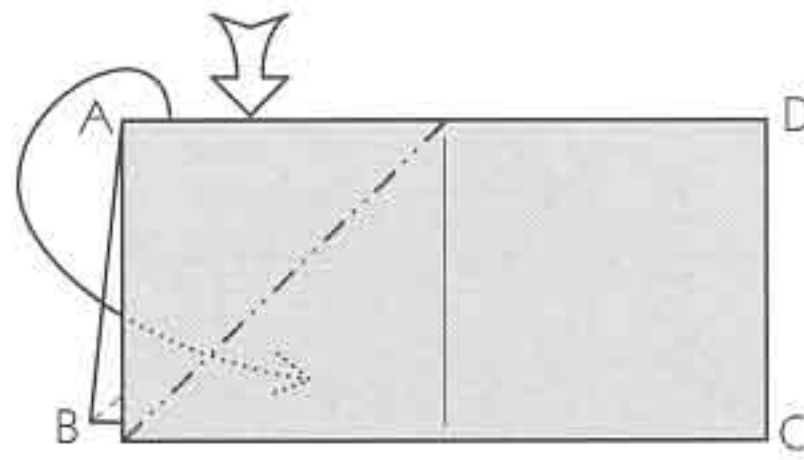

4 Reverse-fold corner A down inside the model on the existing creases.

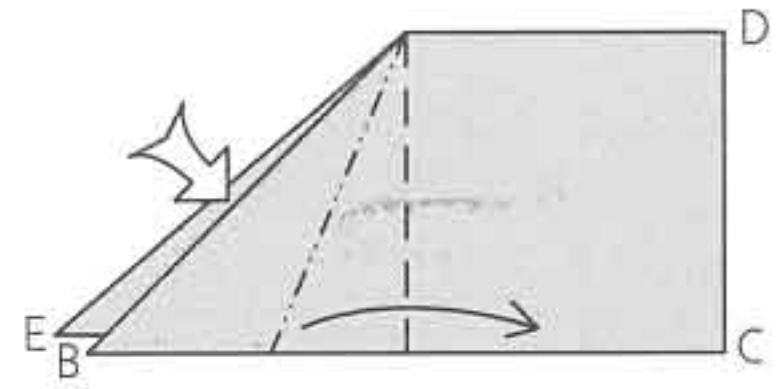

5 Squash-fold corner B symmetrically.

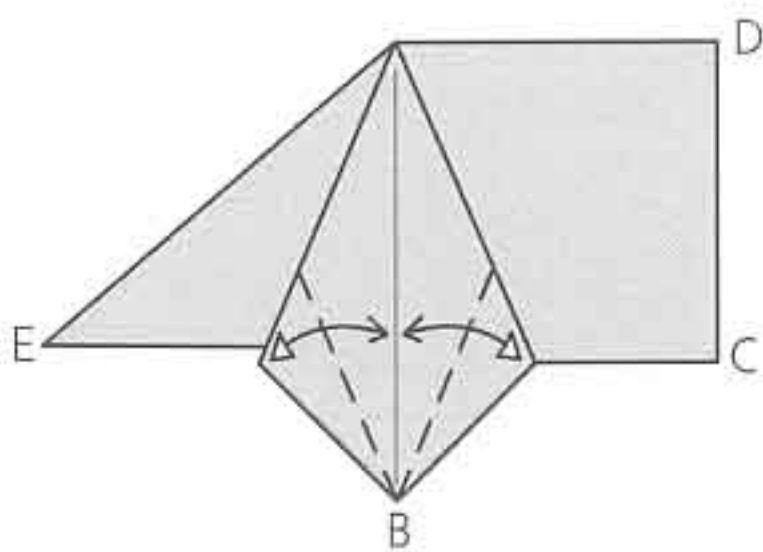

6 Fold in the raw edges to the center and unfold.

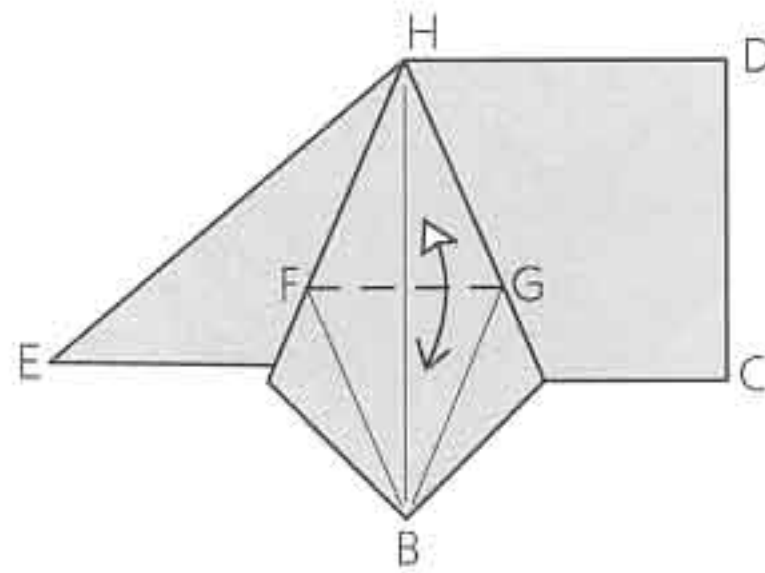

7 Fold down point H to point B along a crease that connects points F and G, folding through all layers of the model. Unfold.

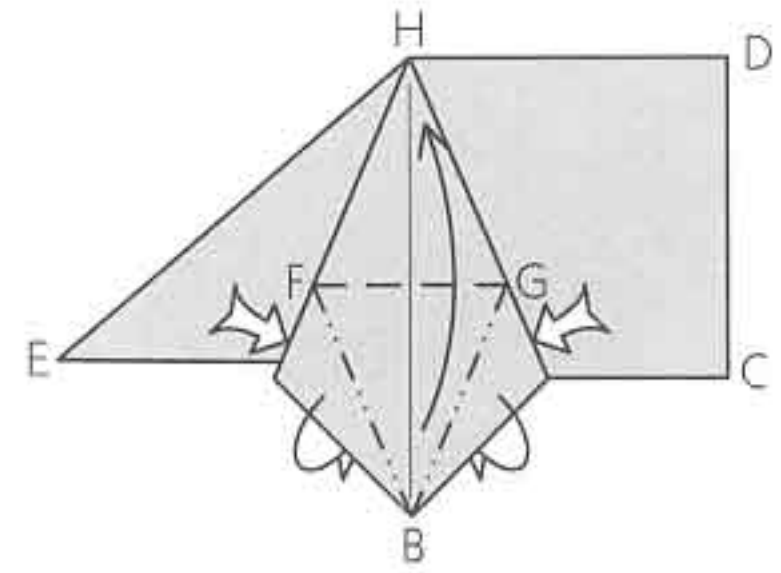

8 Petal-fold point B up to point H, using the existing creases.

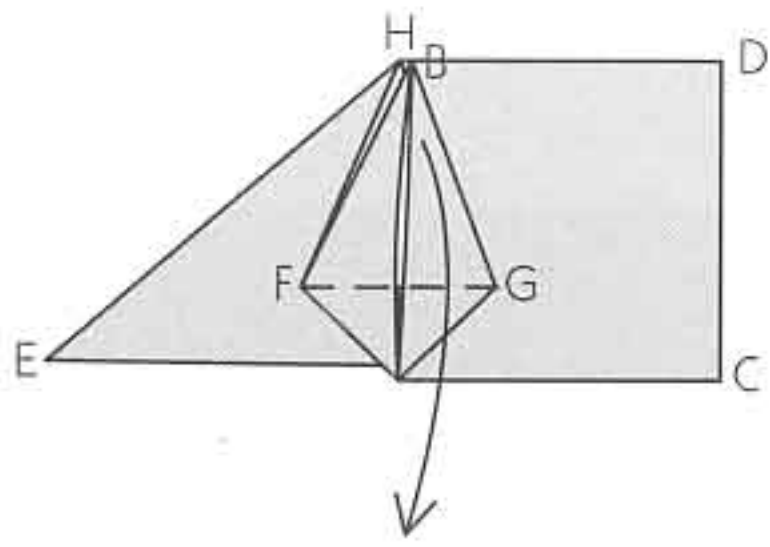

9 Fold point B back down.

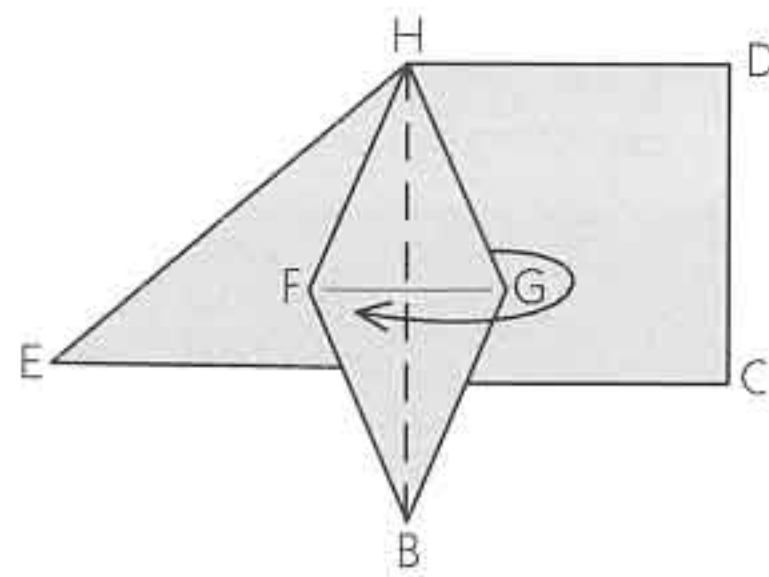

10 Fold corner G to the left.

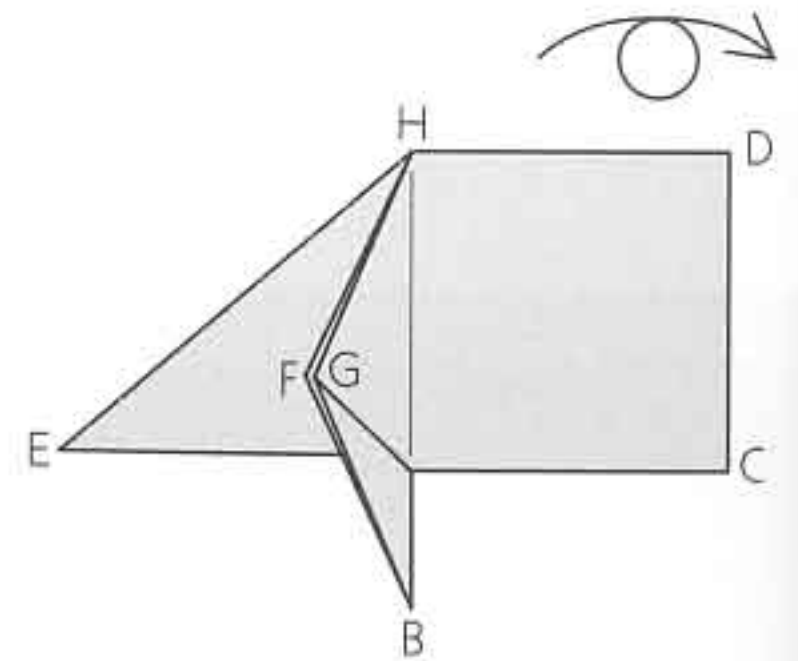

11 Turn over the model.

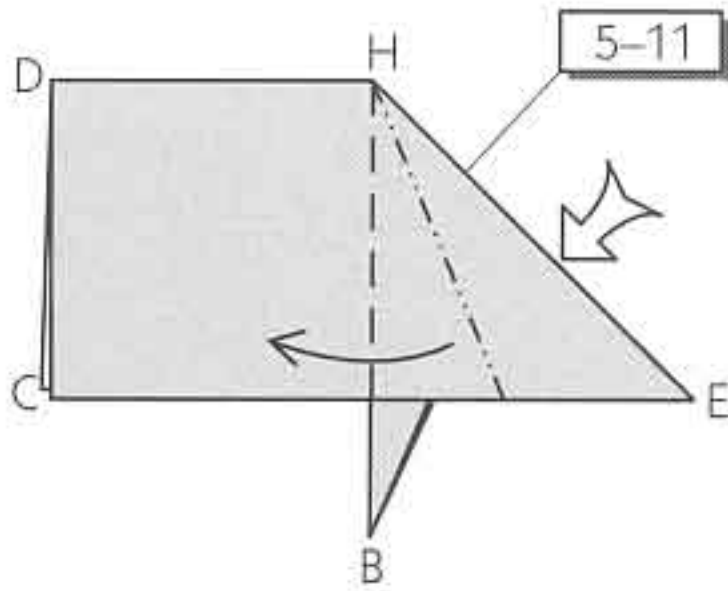

12 Repeat steps 5-11 on flap E (including turning the paper over at the end).

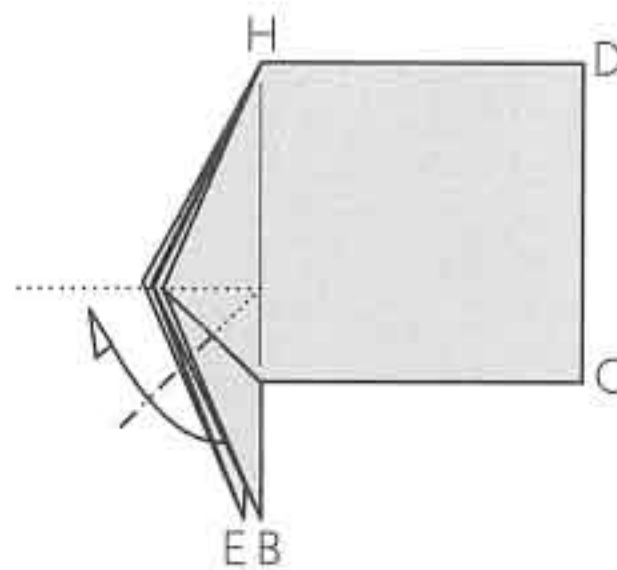

13 Mountain-fold point B underneath and to the left. Rotate the model 1/8 turn clockwise.

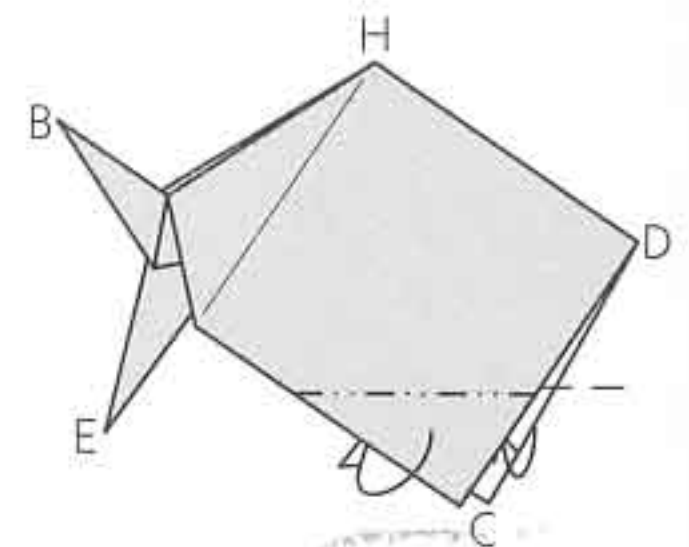

14 Mountain-fold the bottom corners inside. There are no reference points for these folds.

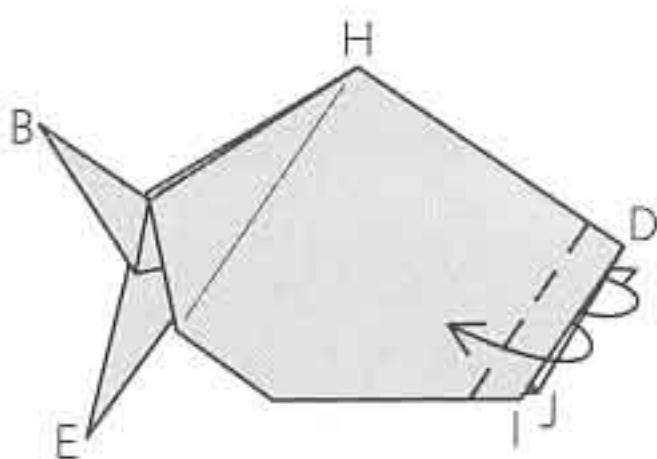

15 Outside-reverse-fold the right edge of the model. (If you spread corners I and J apart, this can be done with a valley fold that runs all the way from I to J.)

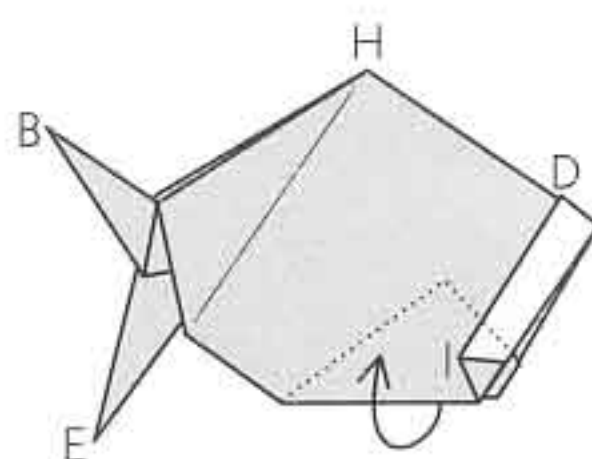

16 Tuck the near layer of the model underneath the colored flap inside.

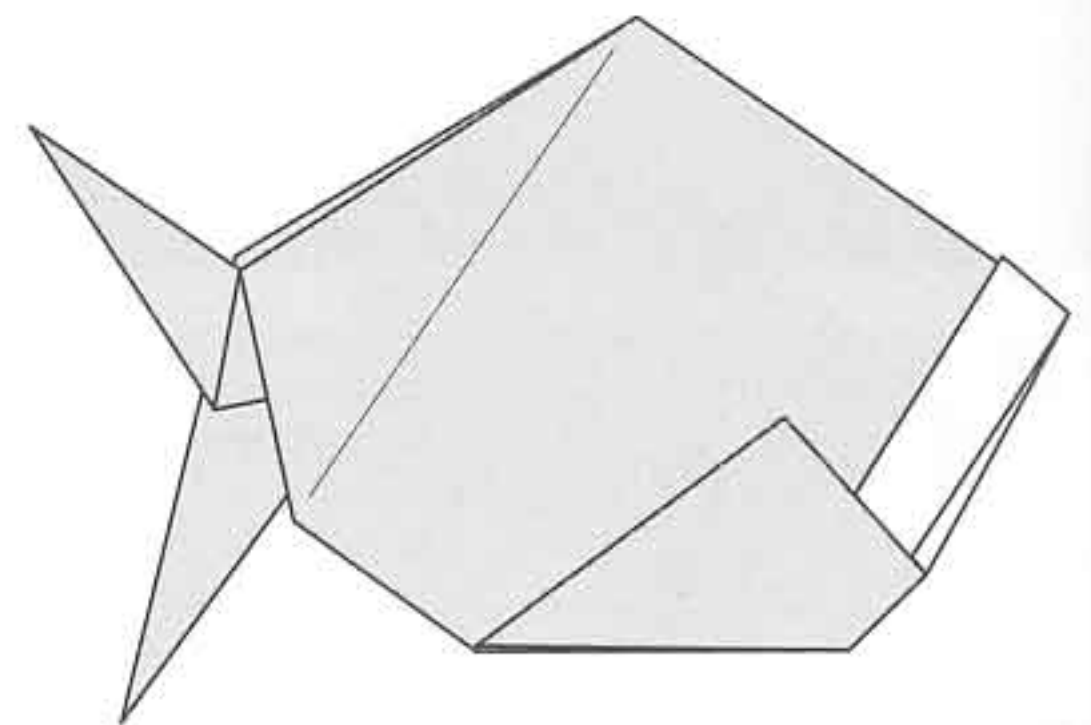

Completed Fish.

◆ skate ◆

designed by Wayne Rickard

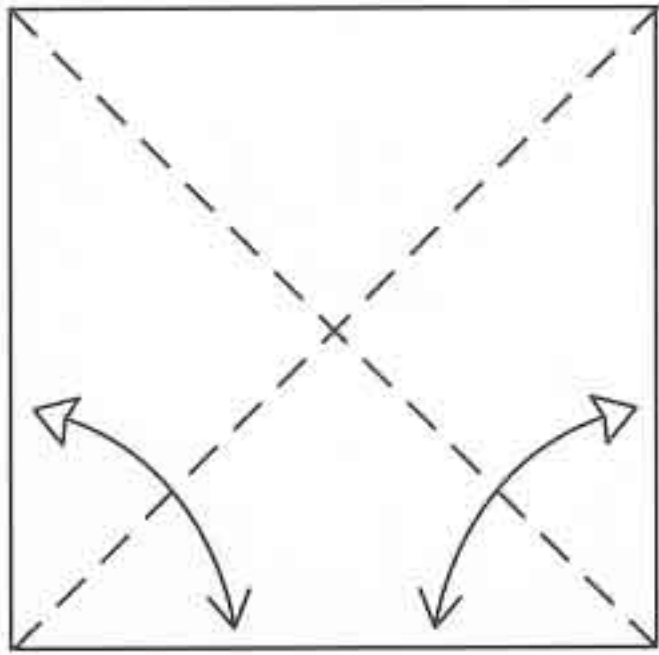

1 Begin with the white side up. Fold the paper in half along the diagonals and unfold.

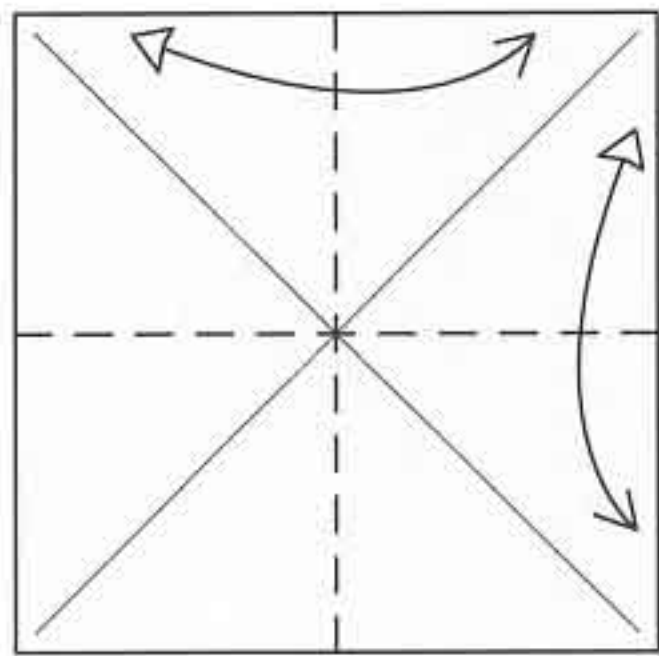

2 Fold the paper in half vertically and horizontally.

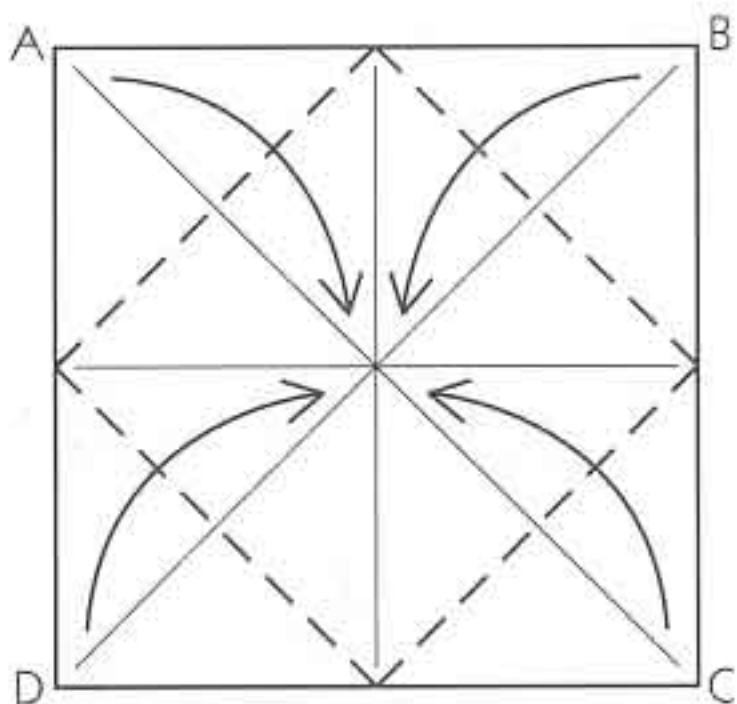
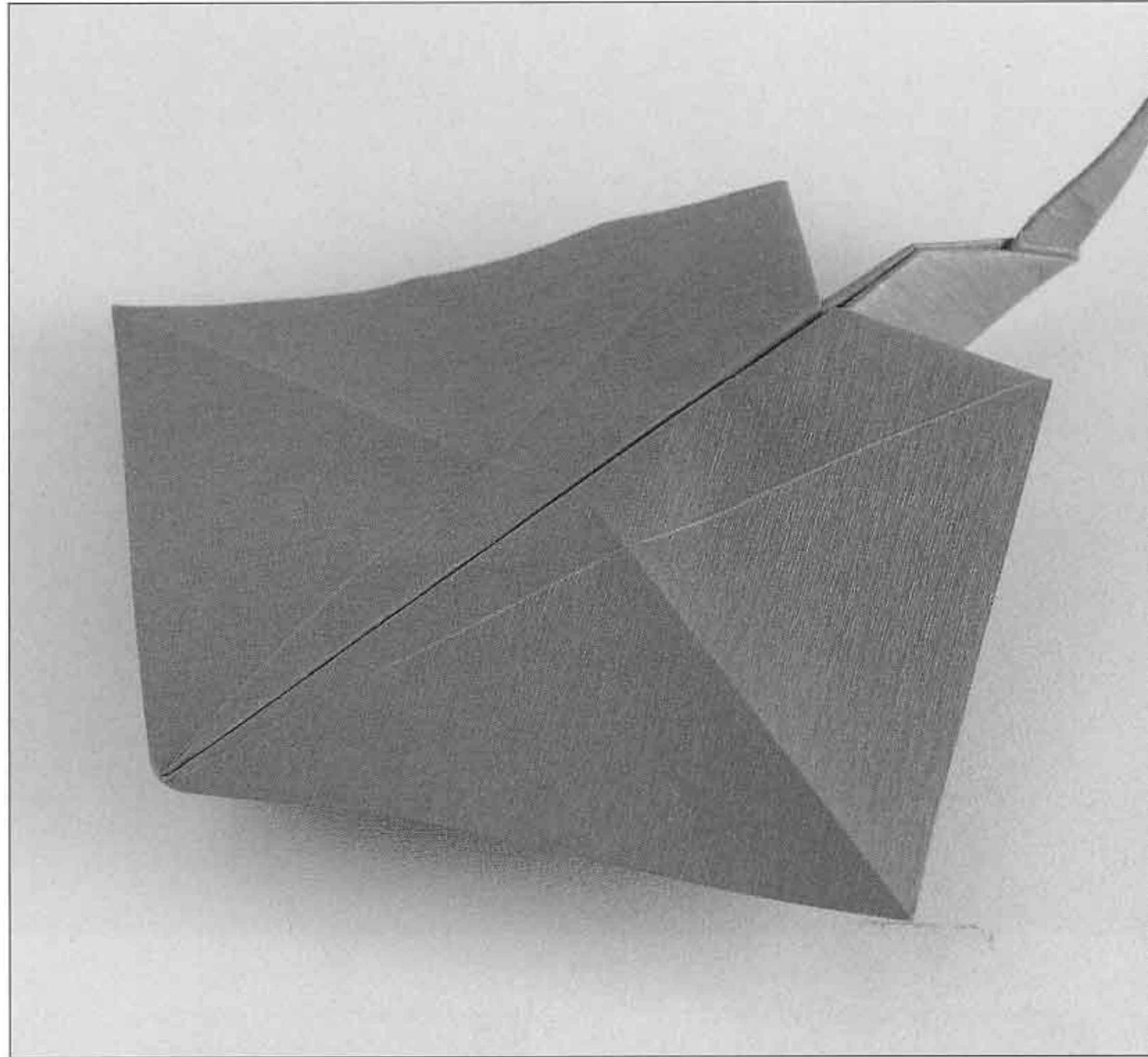

3 Fold the four corners to the center.

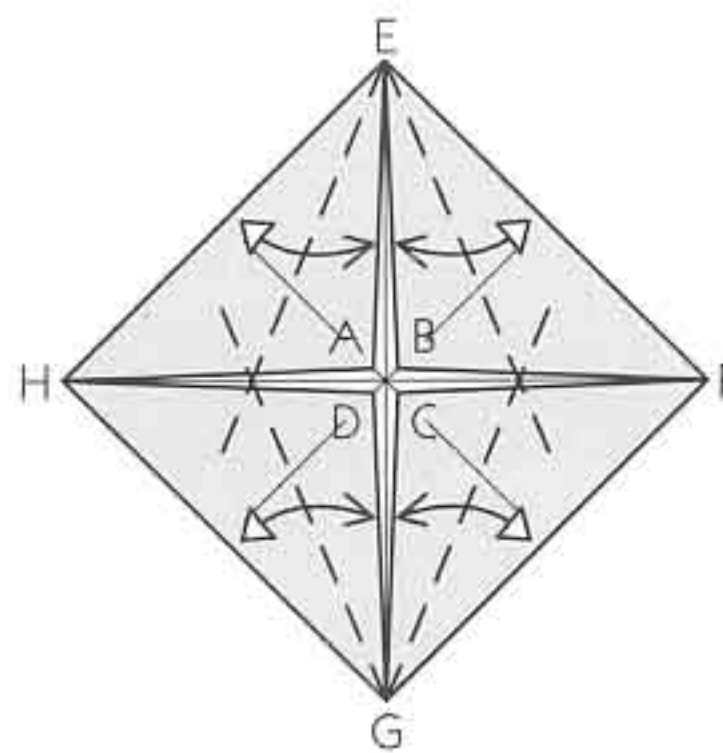

4 Fold edge HG in to lie along the center line EG; crease through both layers and unfold. Repeat on each of the other four edges.

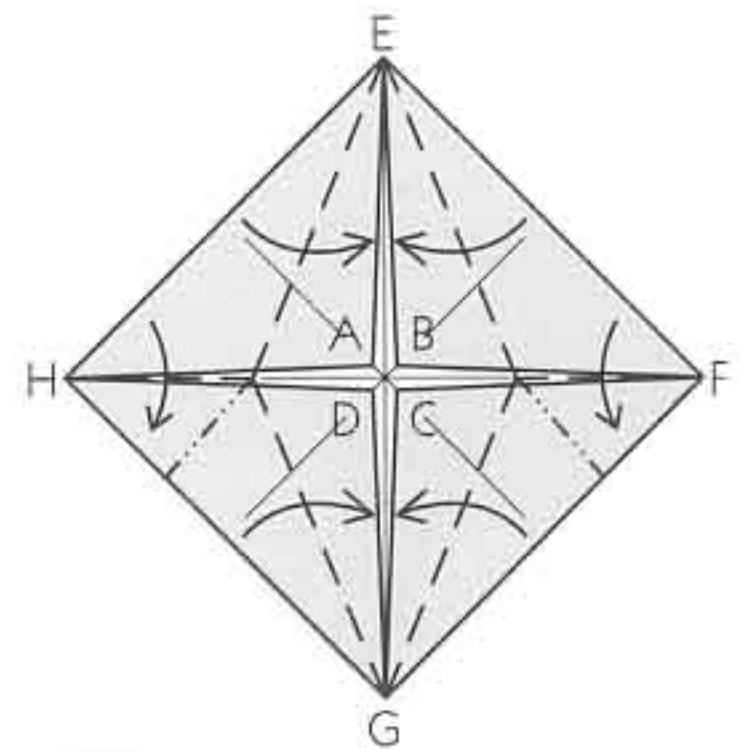

5 Fold a rabbit ear from corners H and F, using the existing creases.

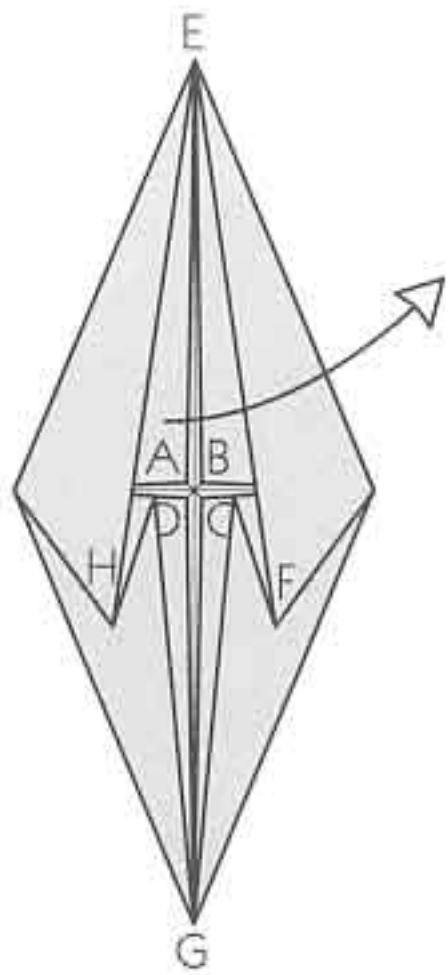

6 Pull corner A out completely.

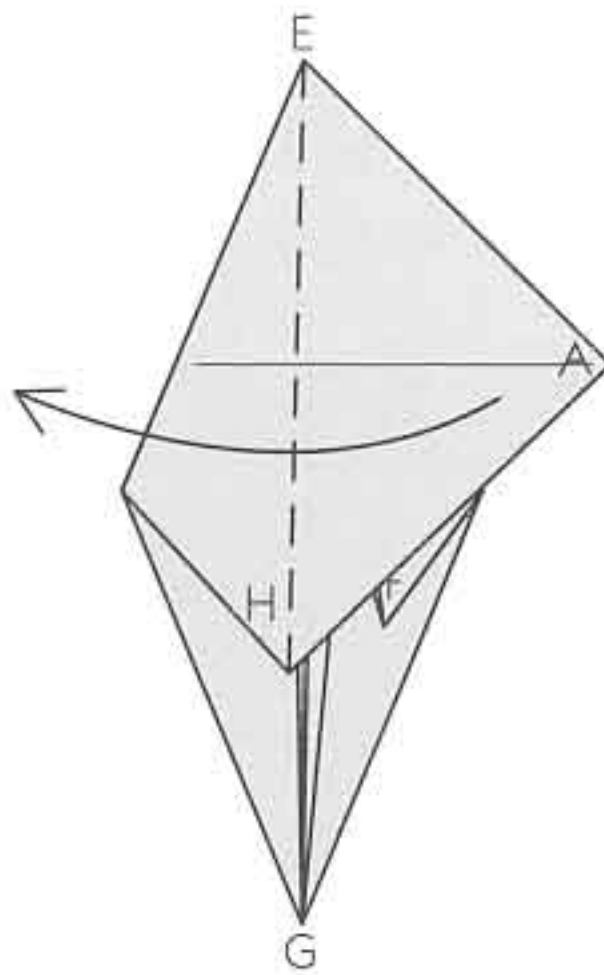

7 Fold corner A back to the left.

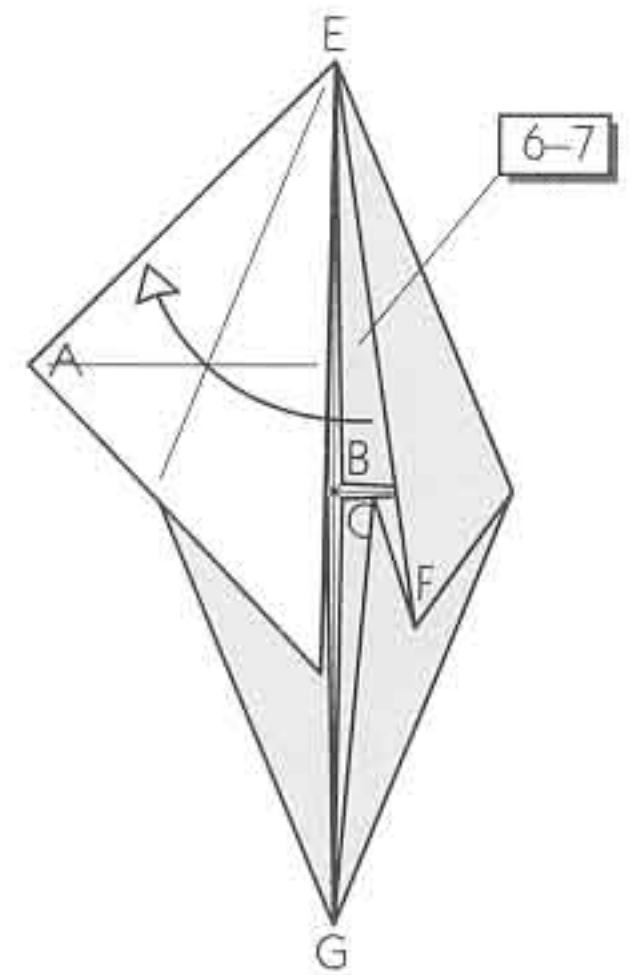

8 Repeat steps 6-7 on corner B.

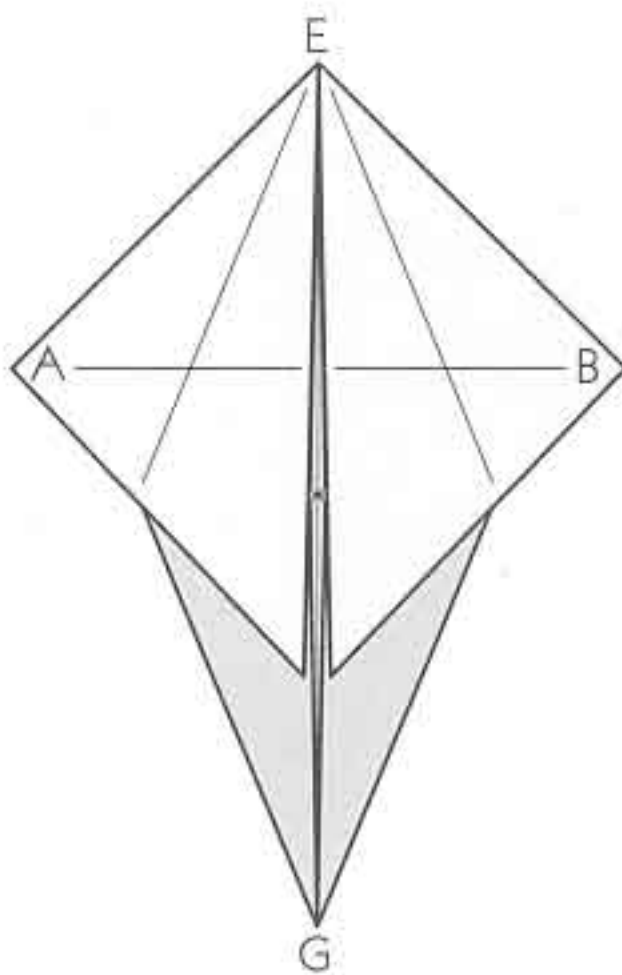

9 Turn the model over.

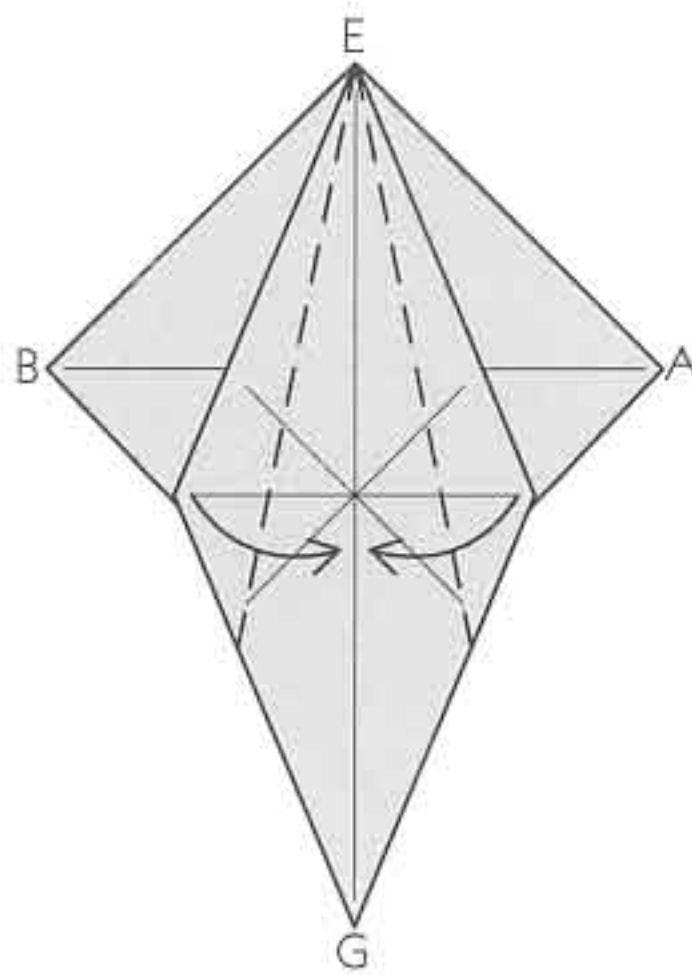
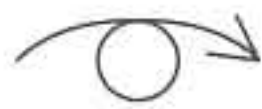

10 Fold the inner edges in to the center.

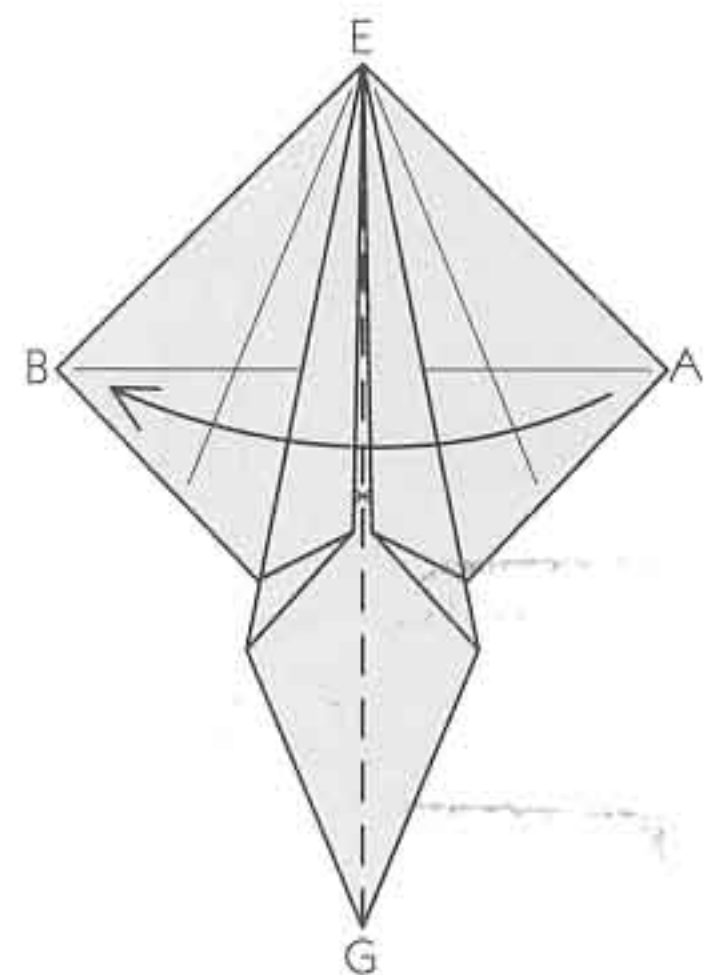

11 Fold the model in half.

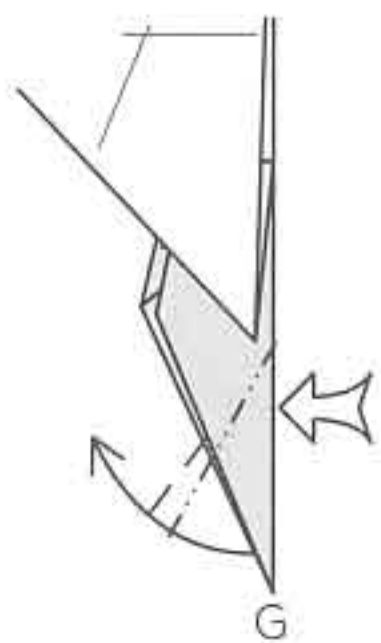

12 Reverse-fold corner G to the left. Then rotate the model 1/4 turn clockwise.

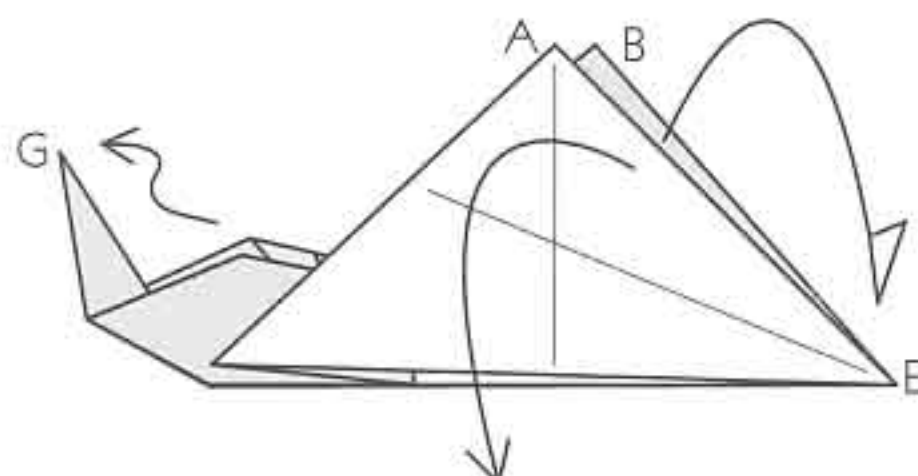

13 Fold corners A and B down to the sides and spread them out. Curl the tail (point G).

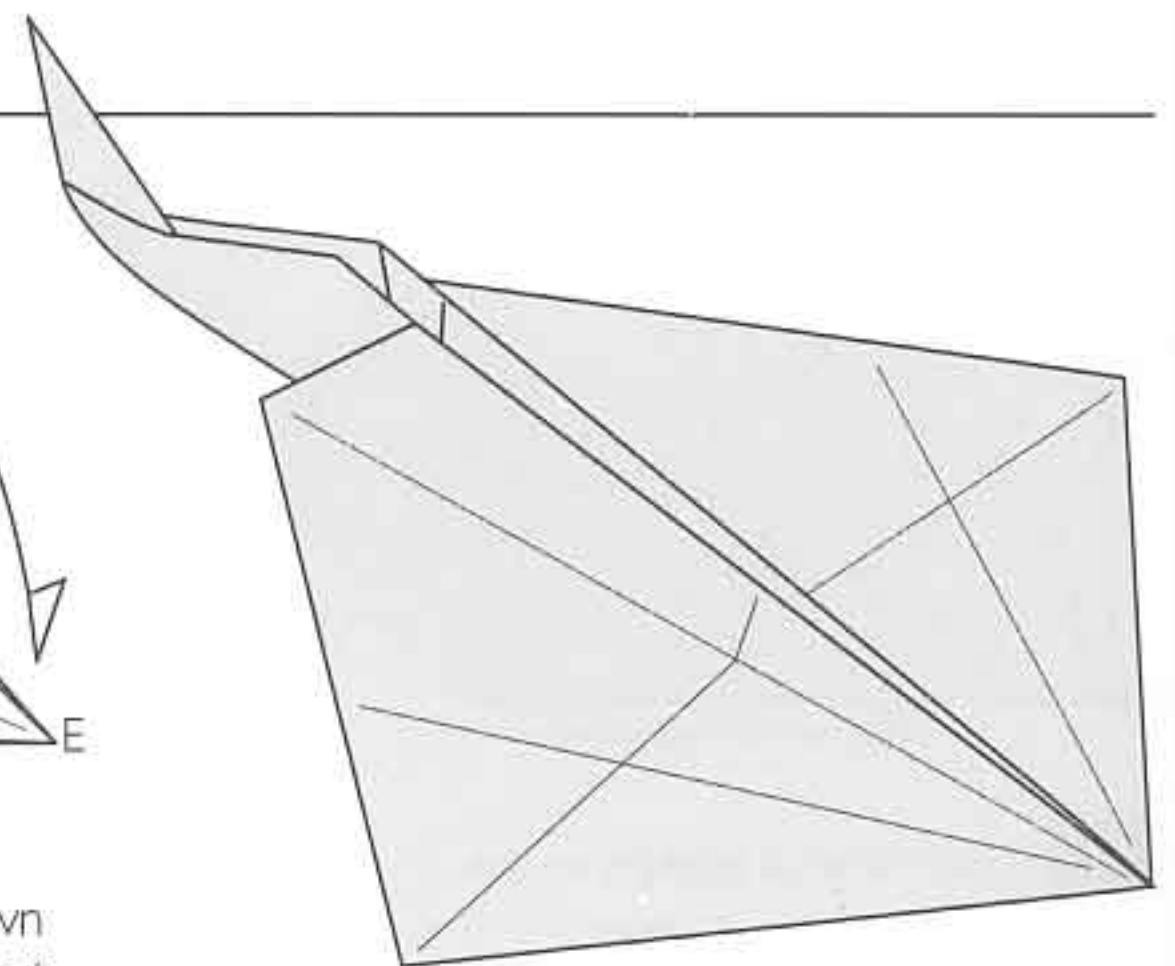

Finished Skate.

◆ gray whale ◆

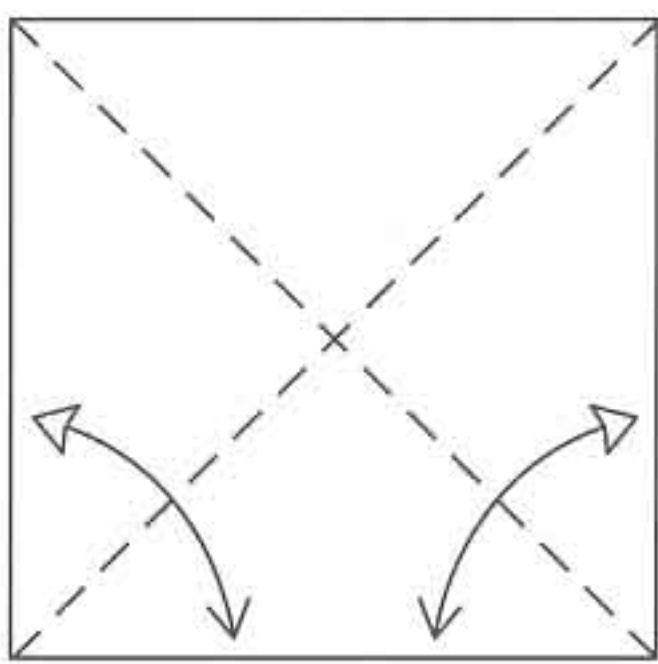
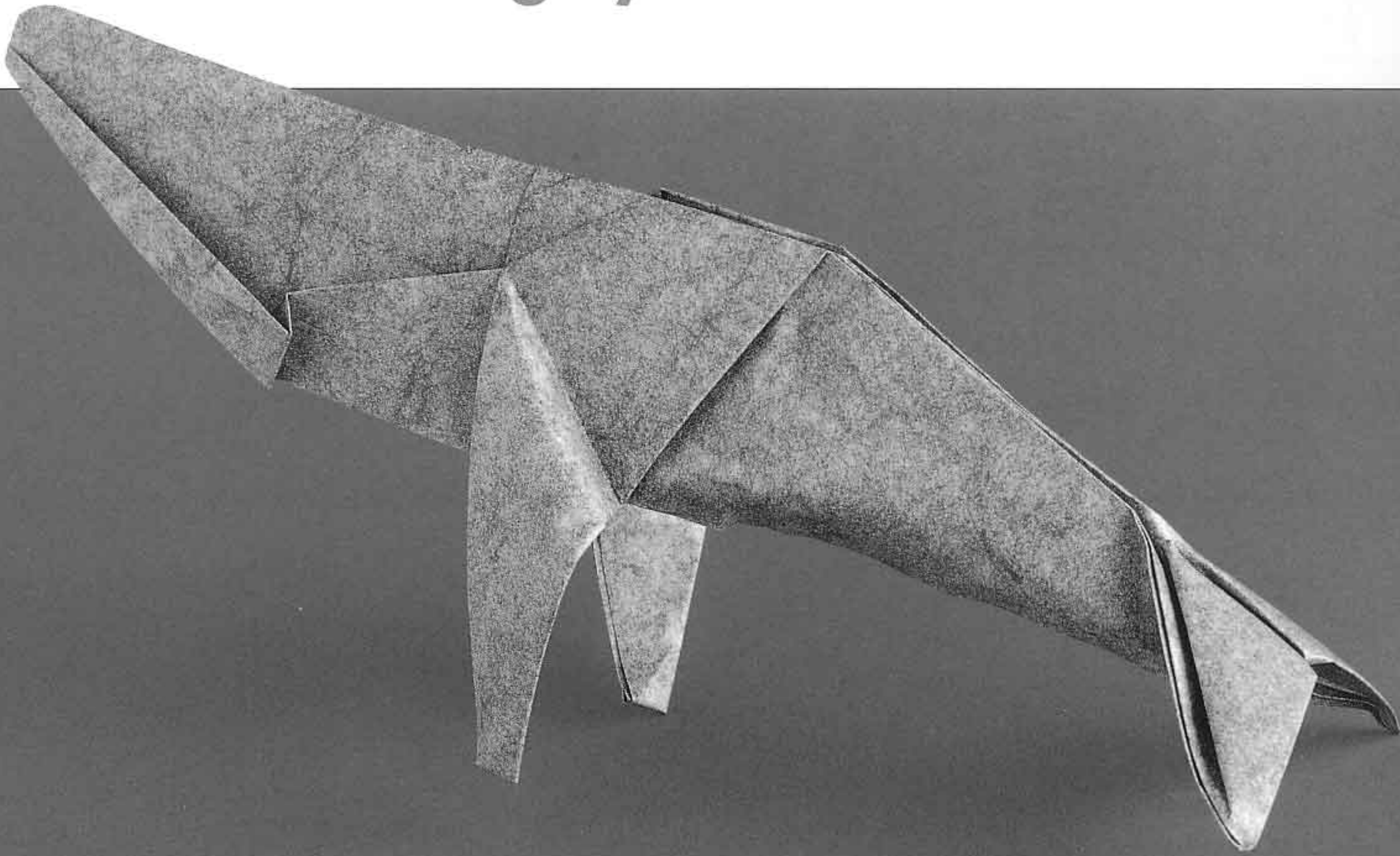

1 Begin with the white side up. Fold the paper in half along the diagonals and unfold. Turn the paper over.

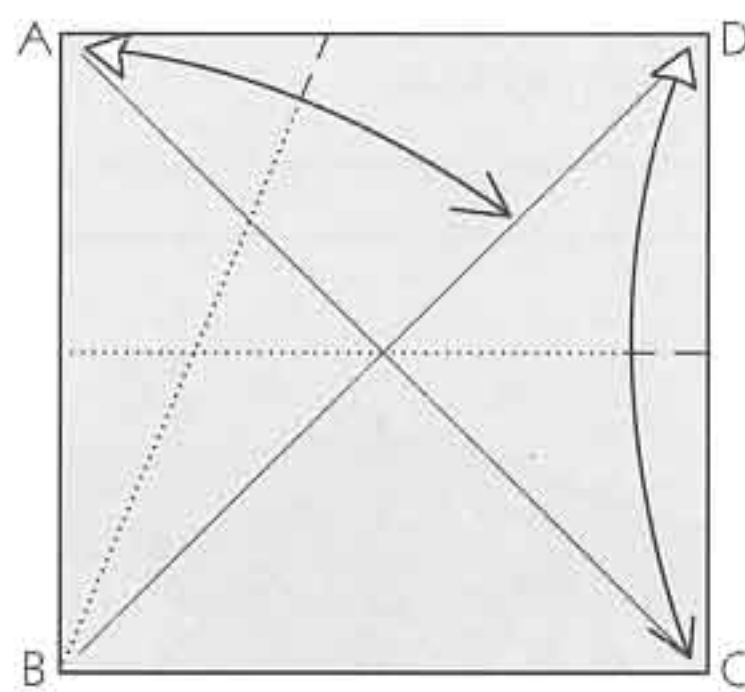
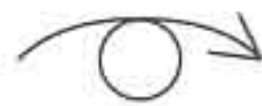

2 Fold edge AB over to lie along the diagonal BD, making the crease sharp only where it hits the top edge (AD). Then fold corner D down to corner C, making the crease sharp only where it hits the right edge (CD).

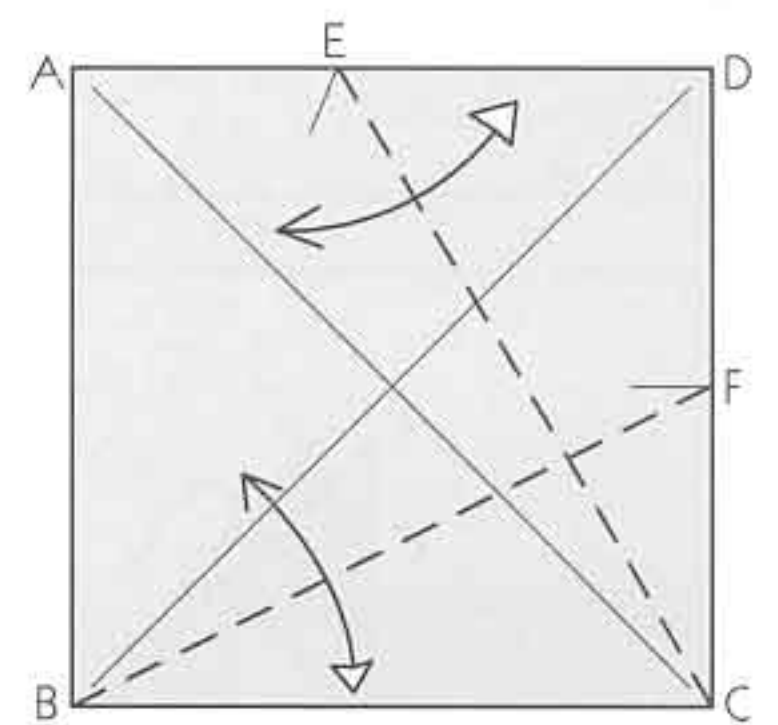

3 Fold corner D down so that the crease runs from corner C to point E and unfold. Fold corner C up so that the crease runs from corner B to point F and unfold.

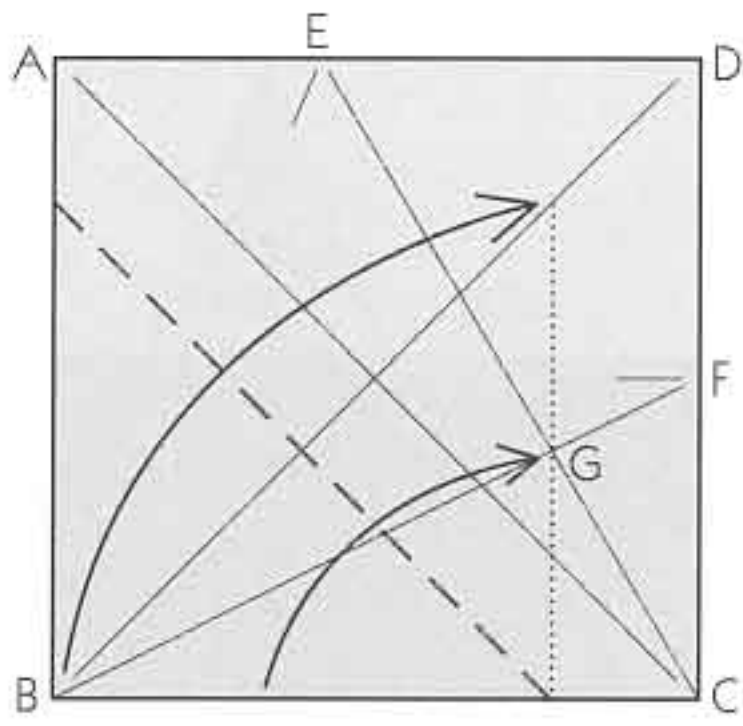

4 Point G marks the intersection of the two creases you just made. Fold corner B up to lie on the diagonal BD while the bottom edge BC runs through point G.

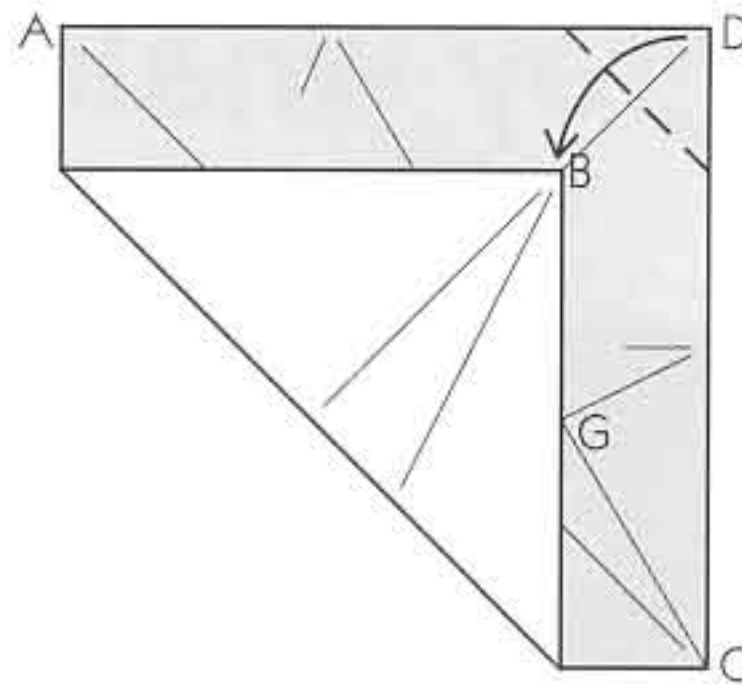

5 Fold corner D down to corner B.

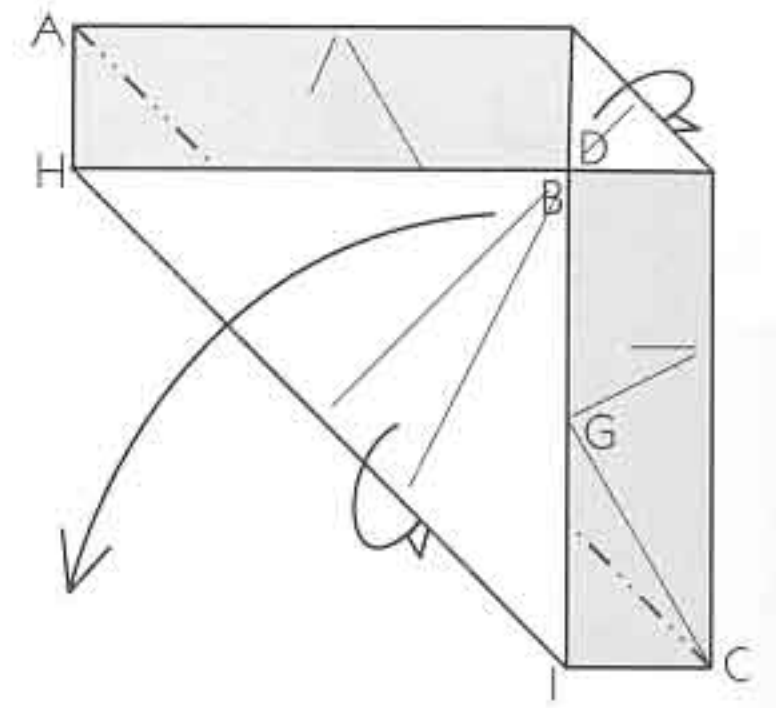

6 Mountain-fold edge HI behind with the crease running along AC, allowing corner B to swing down to the left. Fold corner D behind as well.

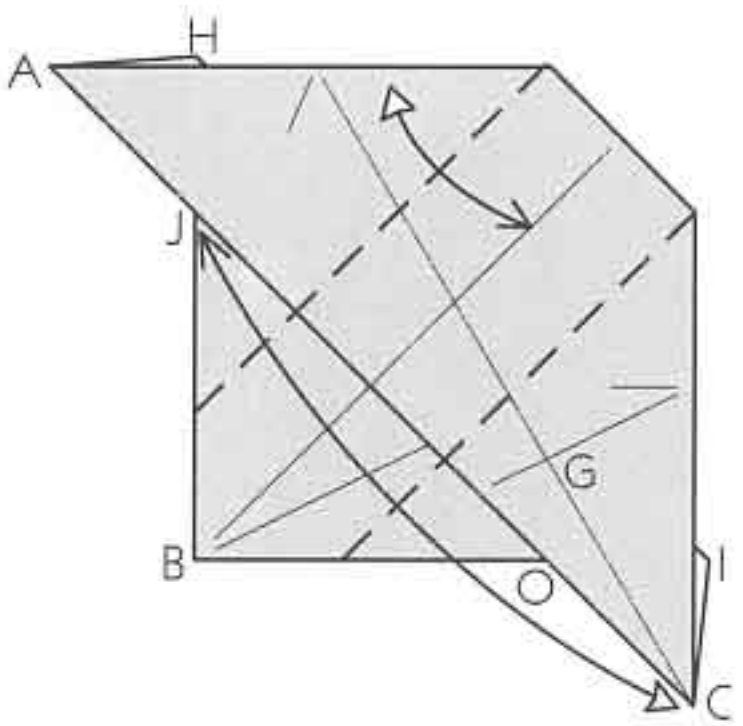

7 Fold corner C up to point J and unfold. Fold point A down to point O and unfold.

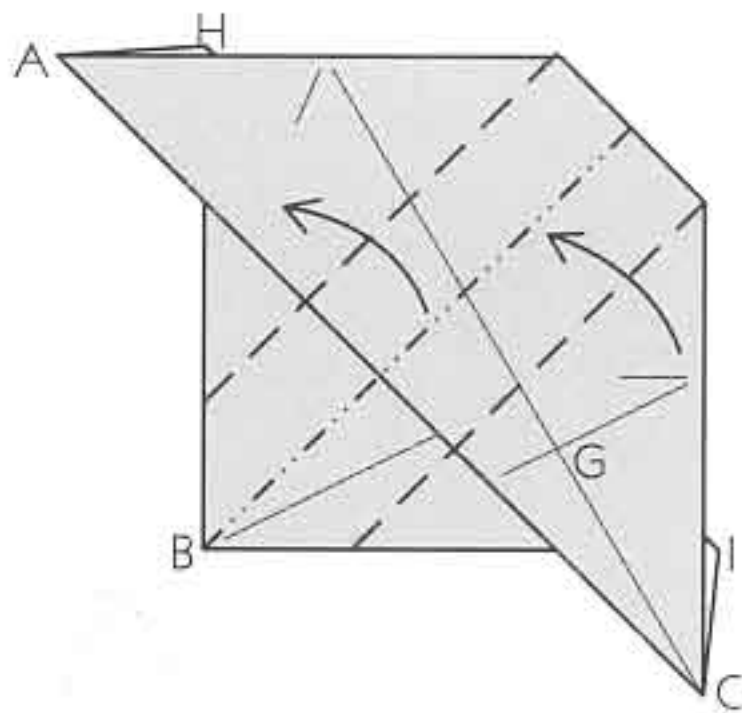

8 Pleat the model using the creases you just made. Rotate 1/8 turn clockwise.

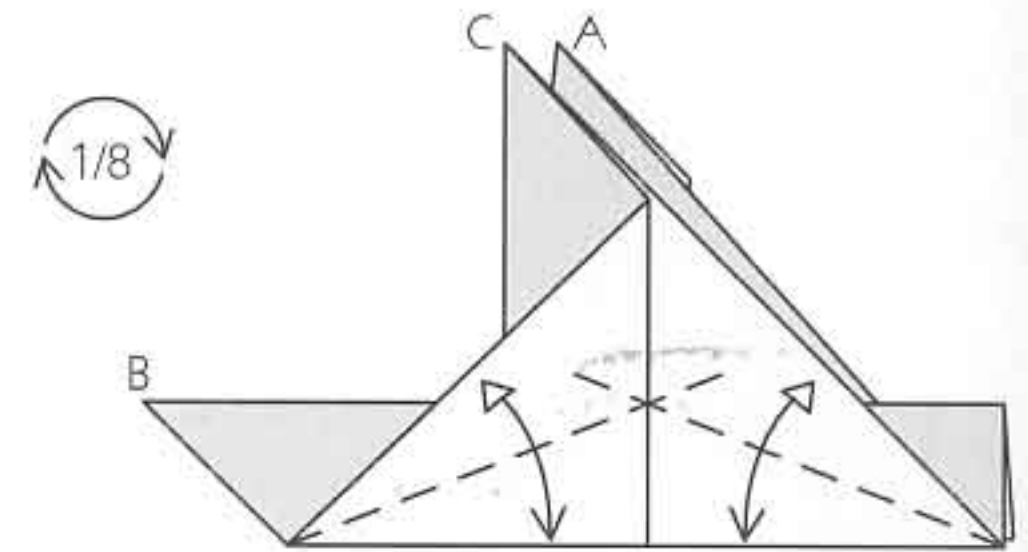

9 Fold and unfold through a single layer of paper. Repeat behind.

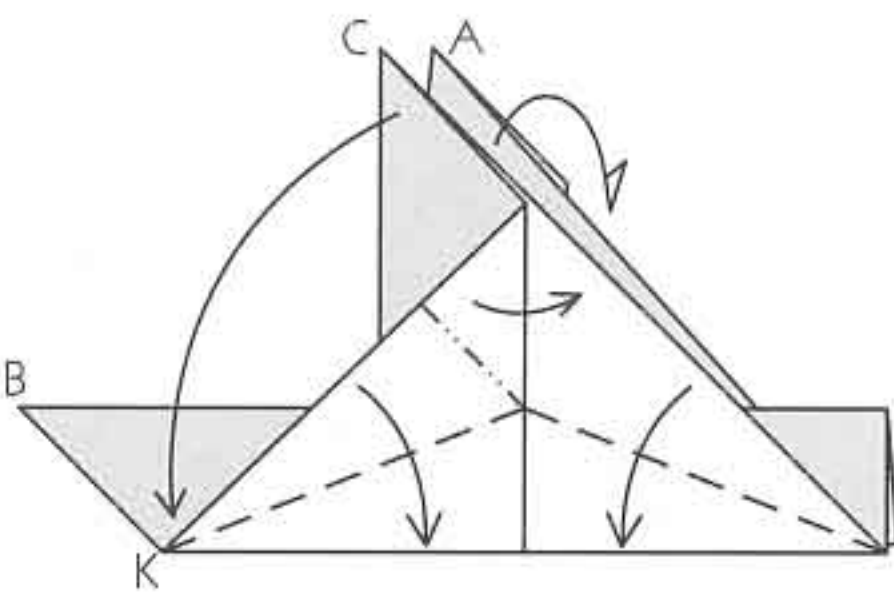

10 Fold a rabbit ear and bring point C down to corner K. Repeat behind on point A.

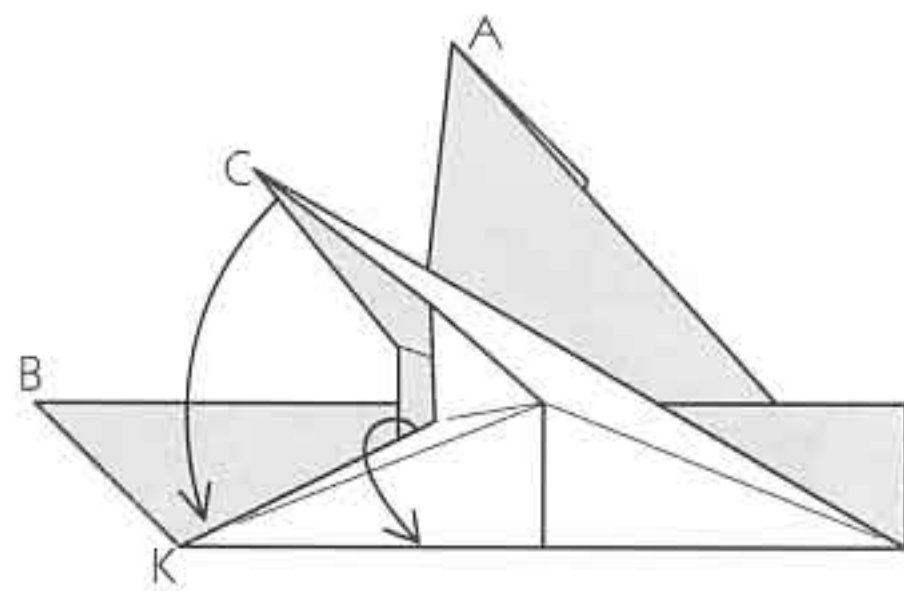

11 In progress.

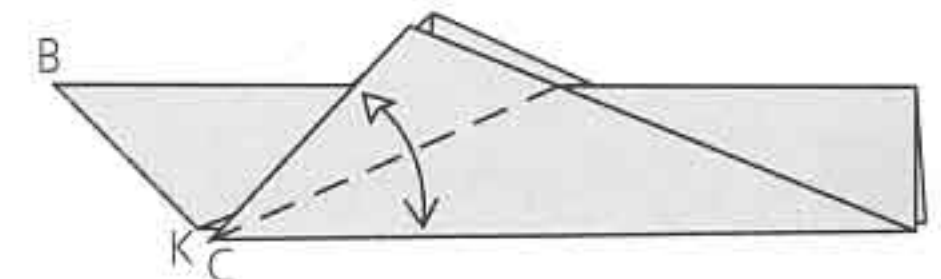

12 Fold and unfold. Repeat behind.

gray whale

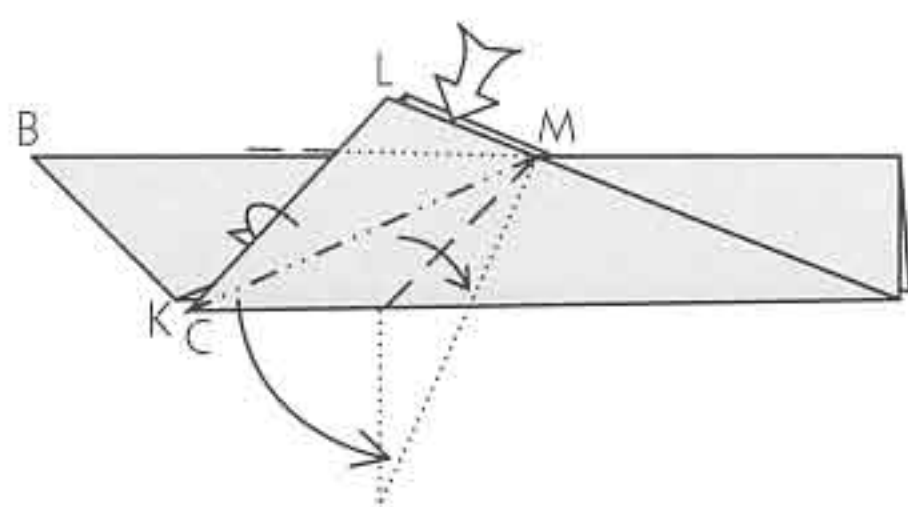

13 Squash the top of edge LM; pinch edge CM in half on the crease you just made (changing it to a mountain fold) and swing it downward.

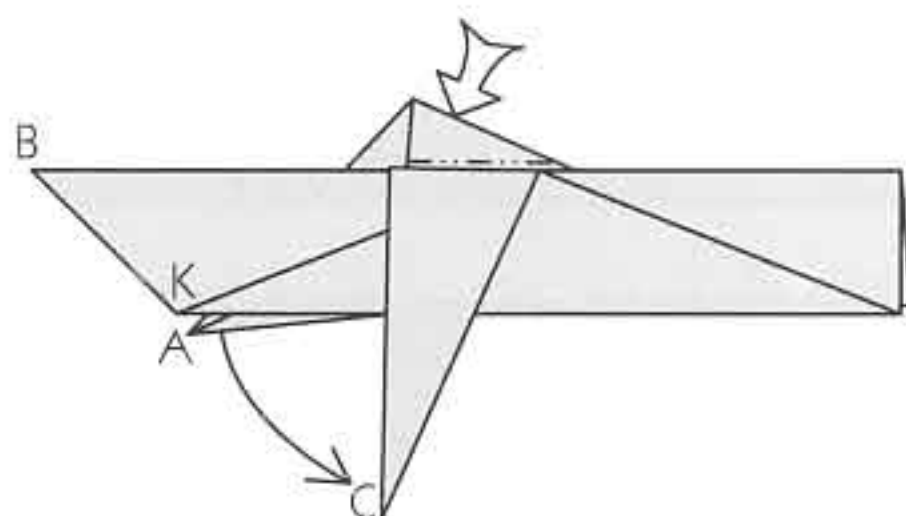

14 Repeat behind on flap A.

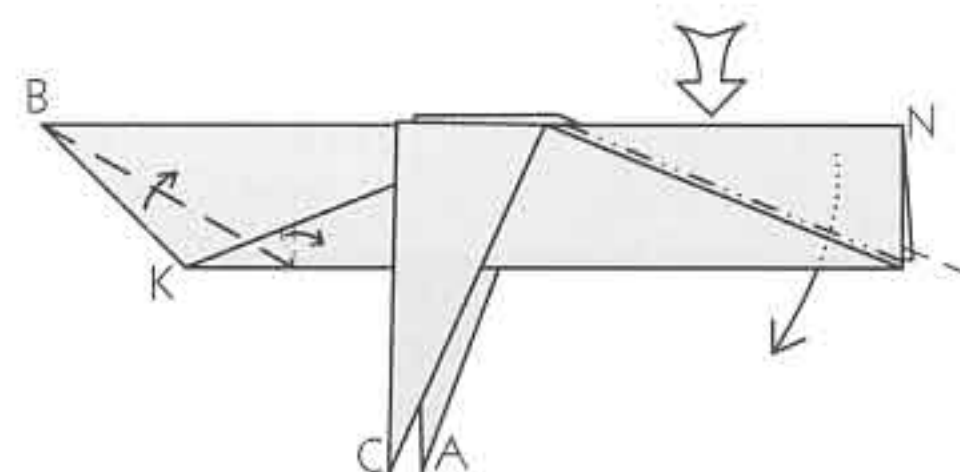

15 Valley-fold corner K upward. Pull the excess paper to the right and pinch flat. Repeat behind. Reverse-fold corner N downward.

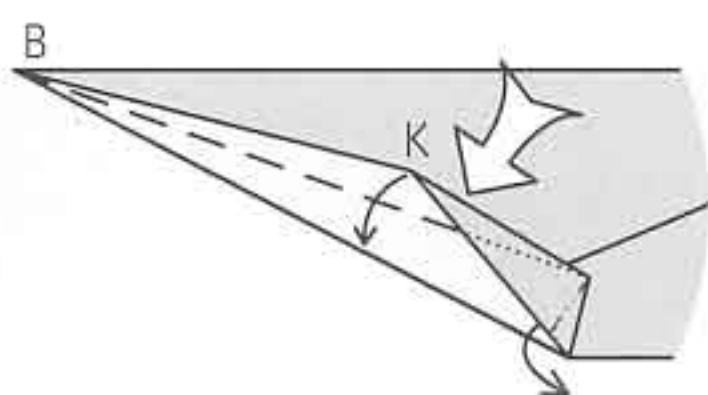

16 Enlarged view of head. Valley-fold corner K downward and pull out the pocket at the lower right to lie flat. Repeat behind.

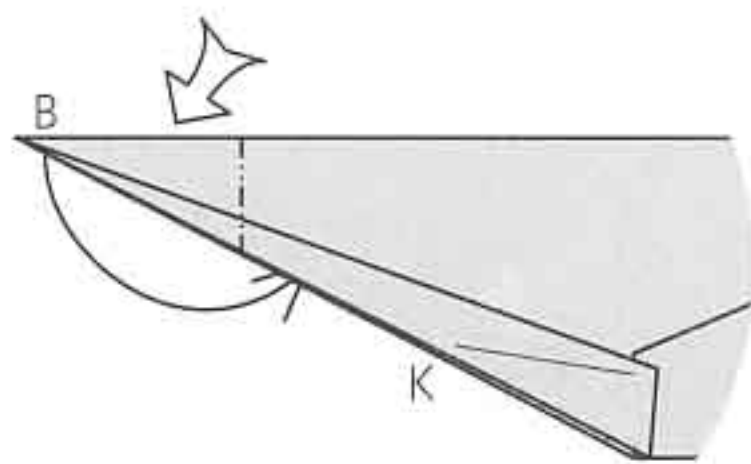

17 Reverse-fold corner B.

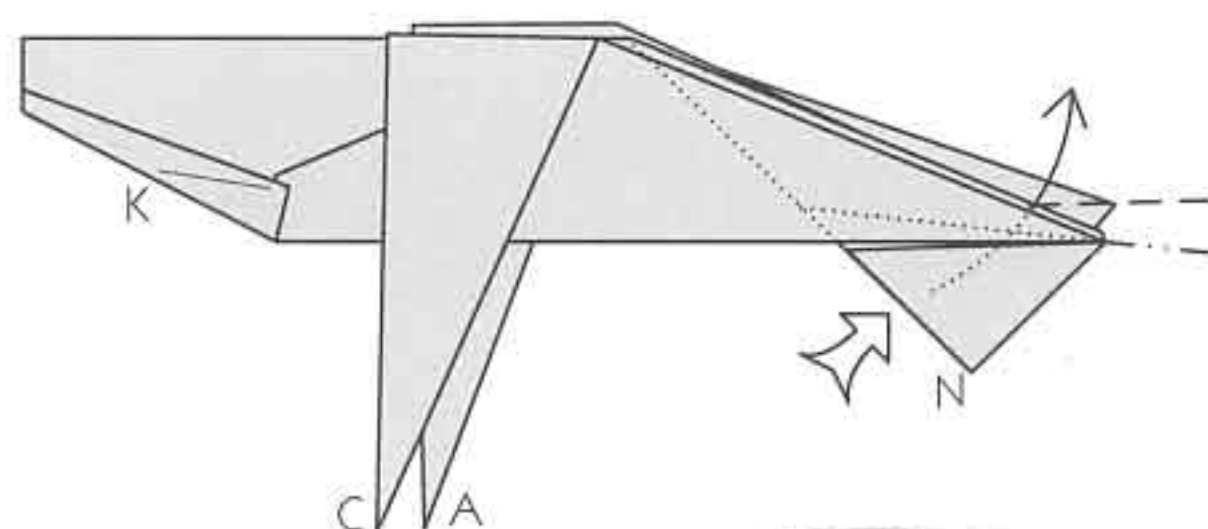

18 Reverse-fold corner N upward.

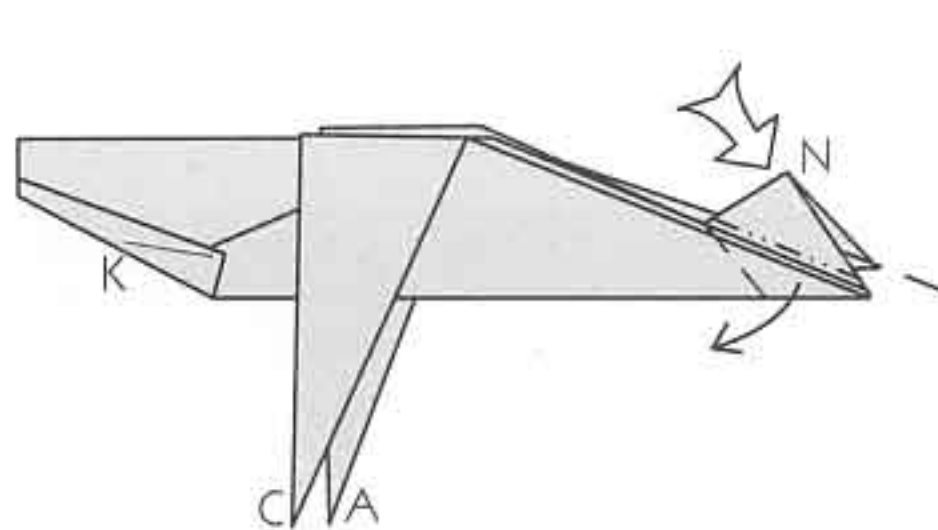

19 Squash-fold the tail (corner N) and spread the flukes.

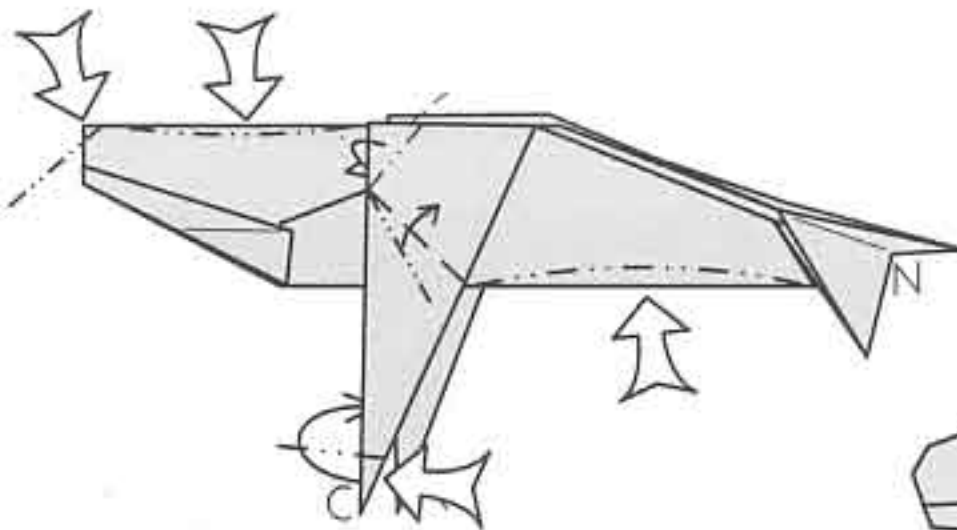

20 Reverse-fold the nose and the tips of the pectoral flukes. Round the body and forehead, and lift and curve the pectoral flukes.

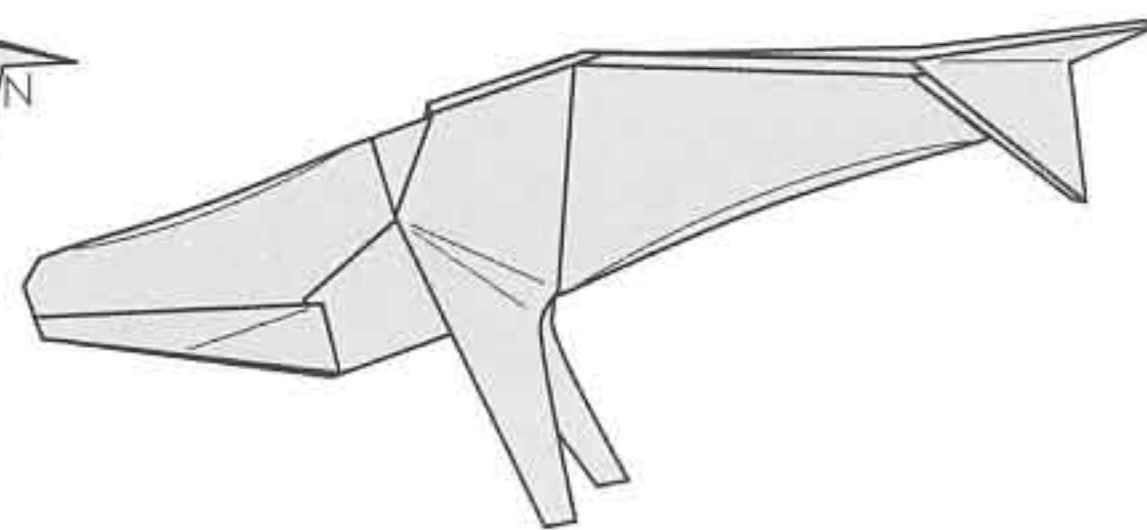

Finished Gray Whale.

◆ Arctic ice ◆



For this project, you will fold the following models:

Name	Page	Rating	Paper requirements
Paddle	69	Easy	6 in (15 cm) square of brown paper
Kayak	71	High Intermediate	10 in (25 cm) square of thin brown paper
Eskimo	74	High Intermediate	12 in (30 cm) square of gray paper
Polar Bear	78	Low Intermediate	12 in (30 cm) square of white or ivory paper

◆ paddle ◆

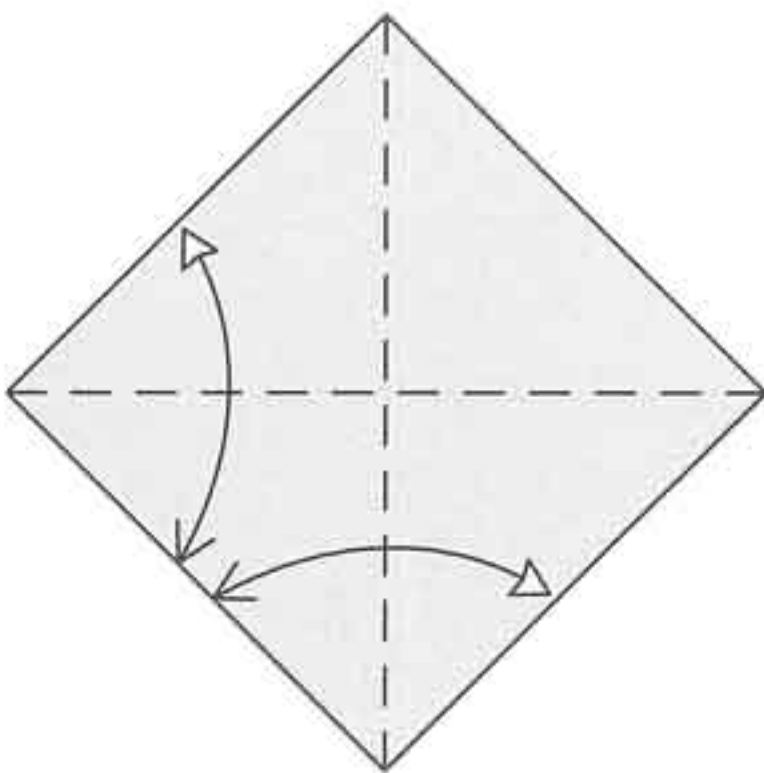
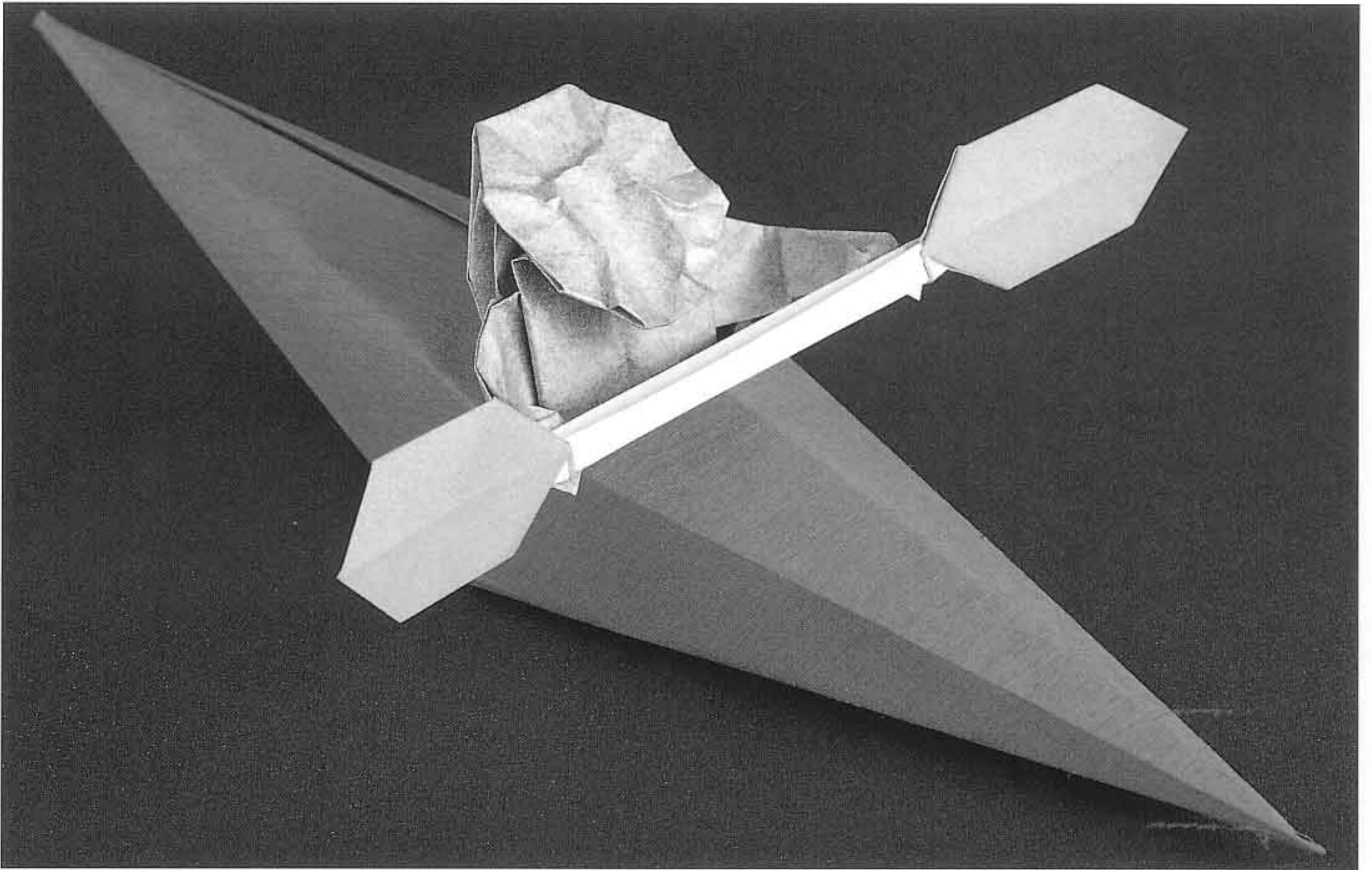

1 Begin with the colored side up. Crease the diagonals.

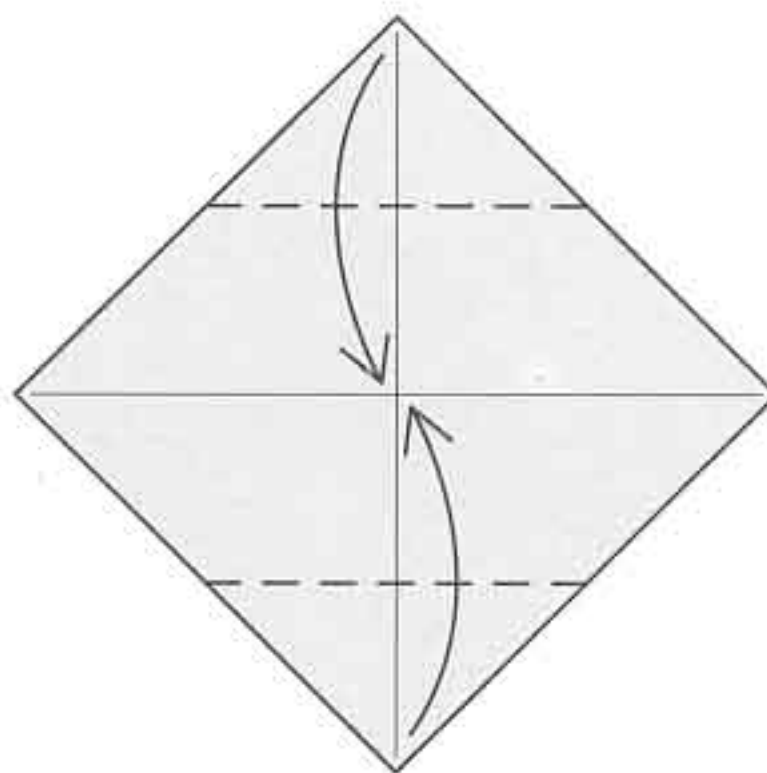

2 Fold the top and bottom corners to the center of the paper.

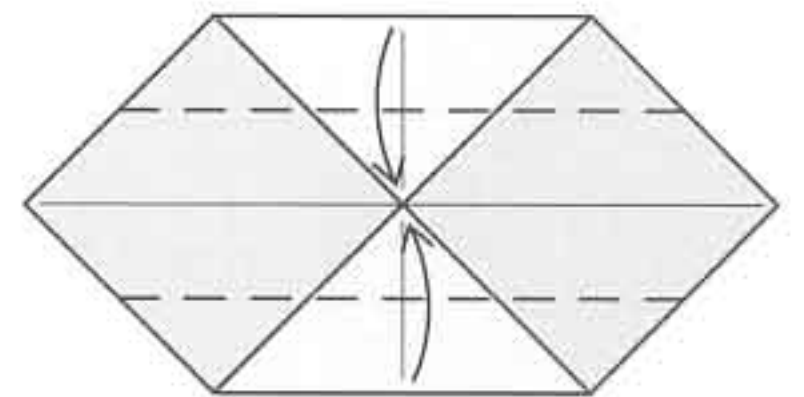

3 Fold the top and bottom edges to the horizontal crease. Be sure that the two corners stay touching in the middle.

Arctic ice

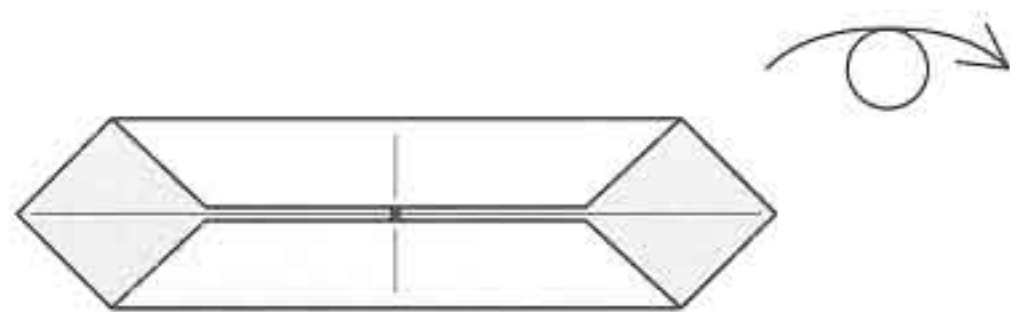

4 Turn the model over.



5 Fold the top and bottom edges to the horizontal crease.

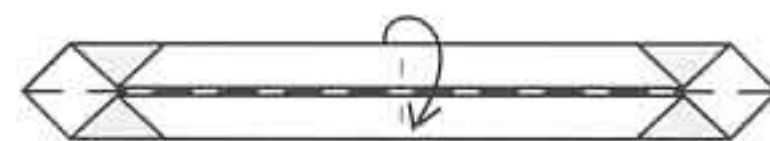

6 Fold down the top half over the bottom.

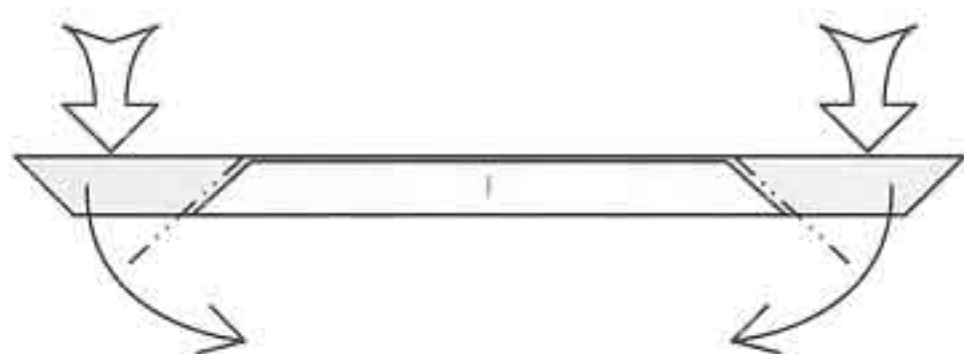

7 Reverse-fold the ends downward on a crease that runs along the border between the white and colored regions.

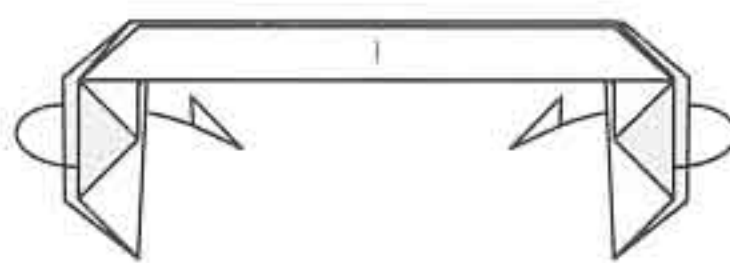

8 Fold the rear layer of each of the downward-pointing flaps behind and toward the center.

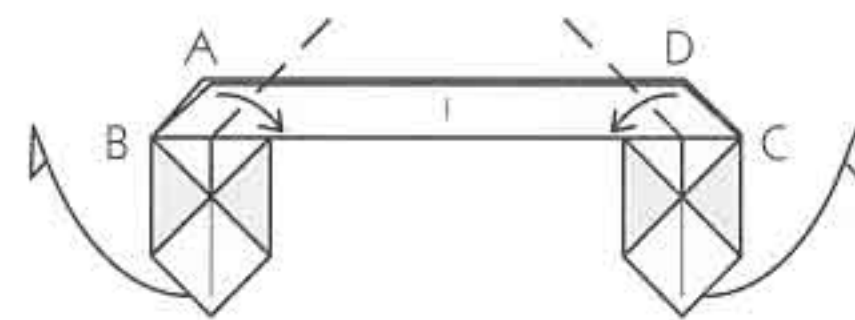

9 Fold down corners A and D to lie on edge BC; the two downward-pointing flaps swing out to the sides.

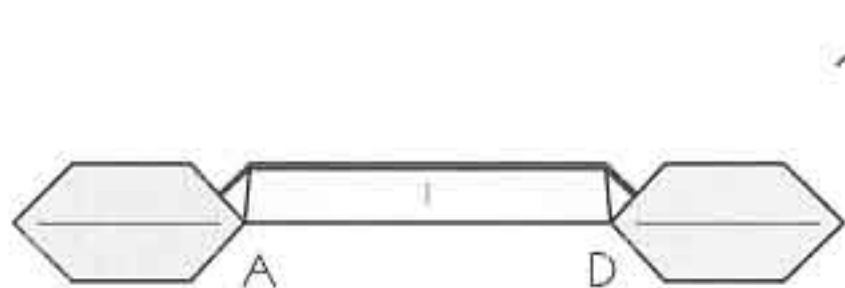

10 Turn the model over.

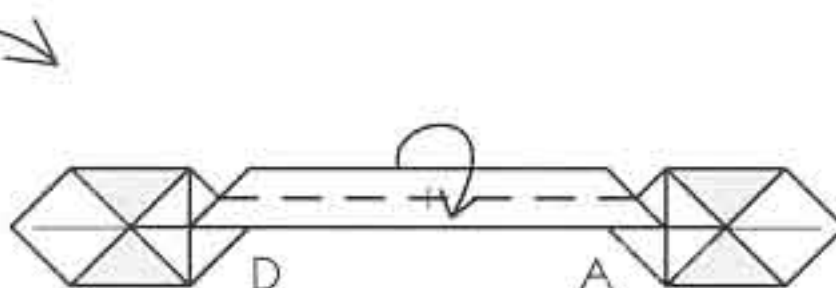

11 Fold the handle in half again. Turn the model over.

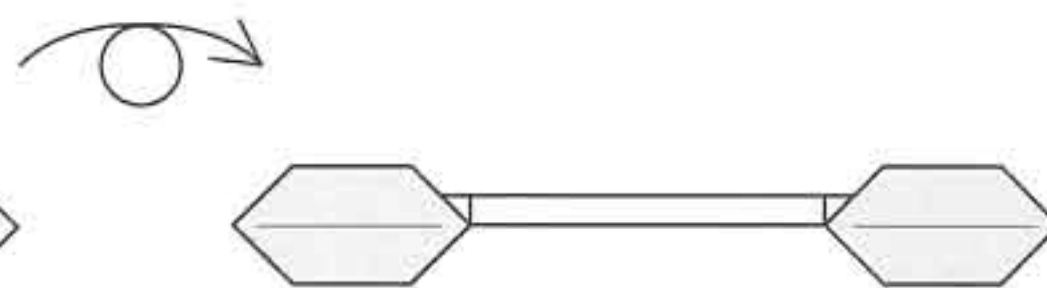

12 Finished Paddle.

◆ kayak ◆

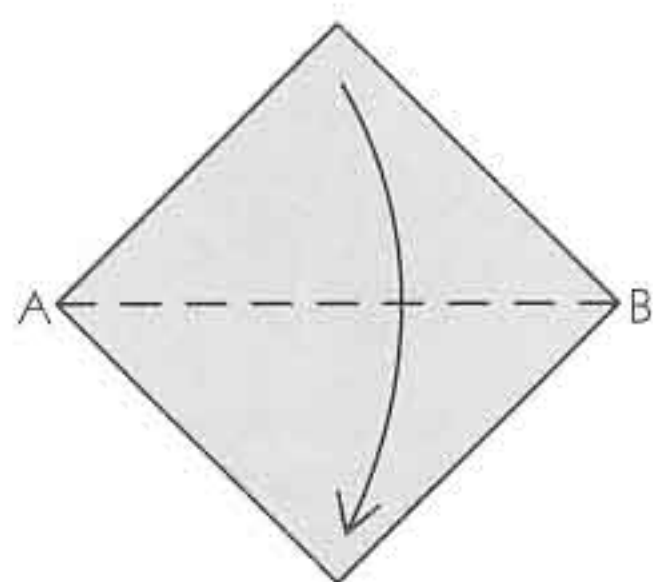

1 Begin with the colored side up. Fold down the top corner to the bottom along line AB.

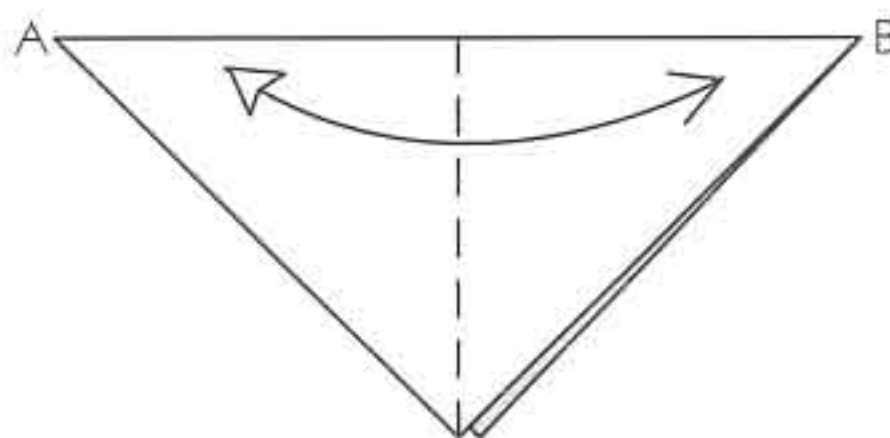

2 Fold the left corner (A) over to the right (B) and unfold.

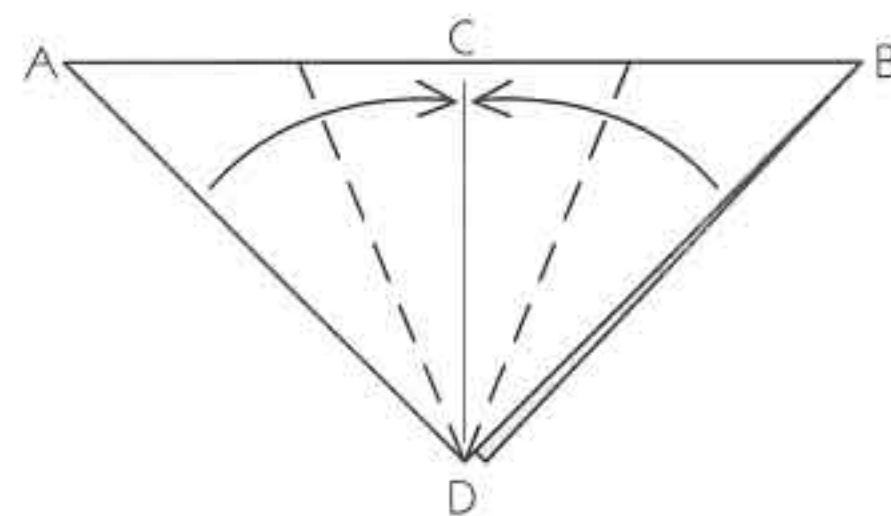

3 Fold in edge AD to lie along the center line CD. Fold edge BD in the same way.

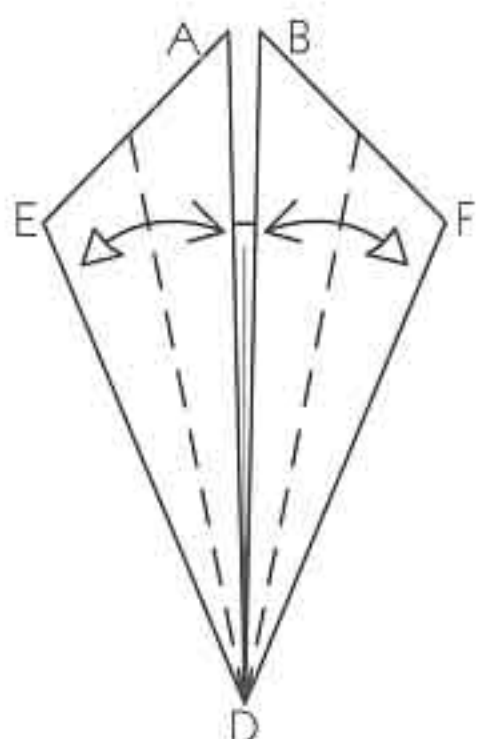

4 Fold in edges ED and FD to meet at the center line; crease firmly and unfold.

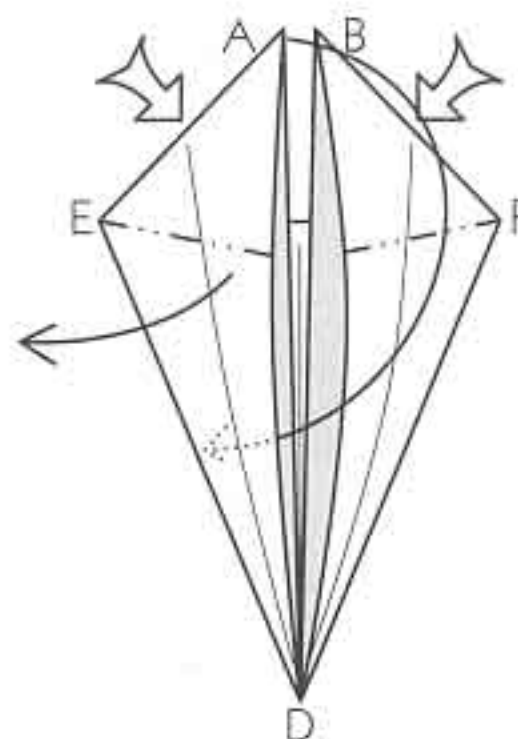

5 Squash-fold point A down to lie on line ED. Repeat on the right on point B.

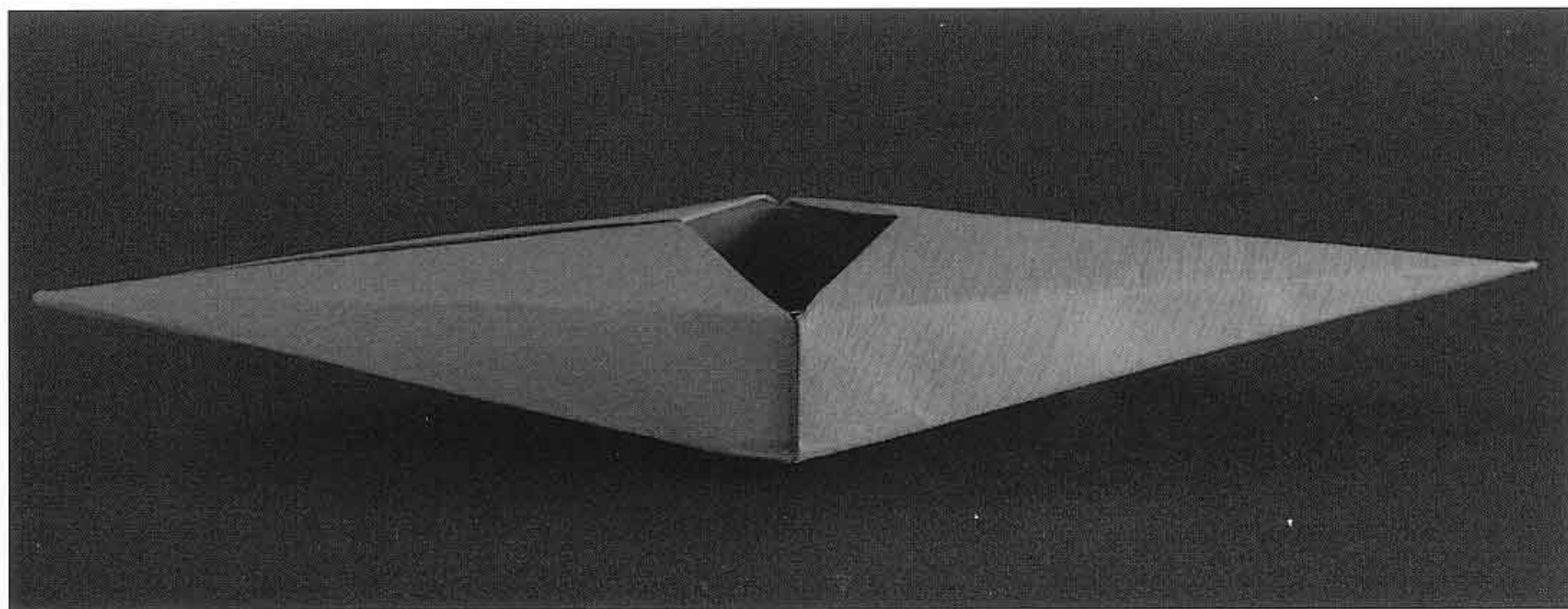

Arctic ice

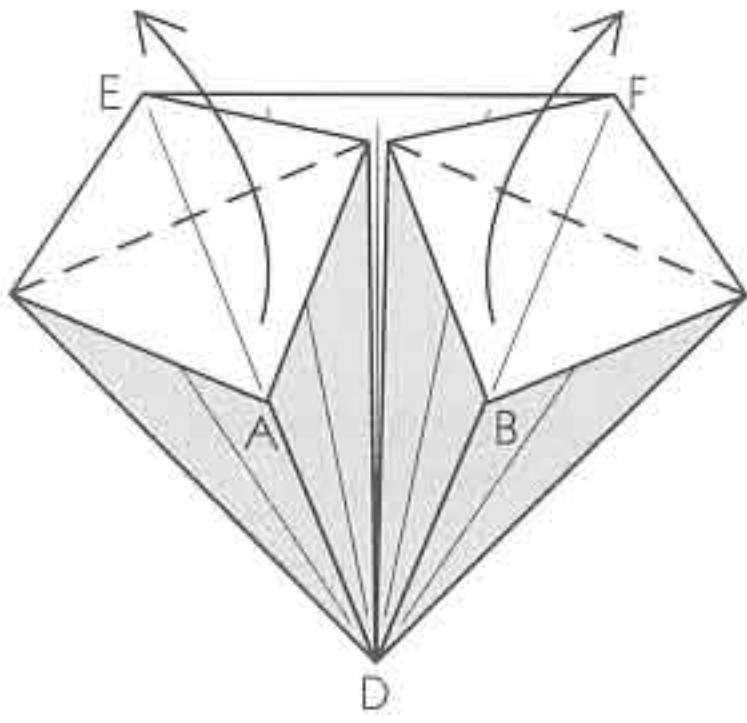

6 Fold corners A and B up as far as possible.

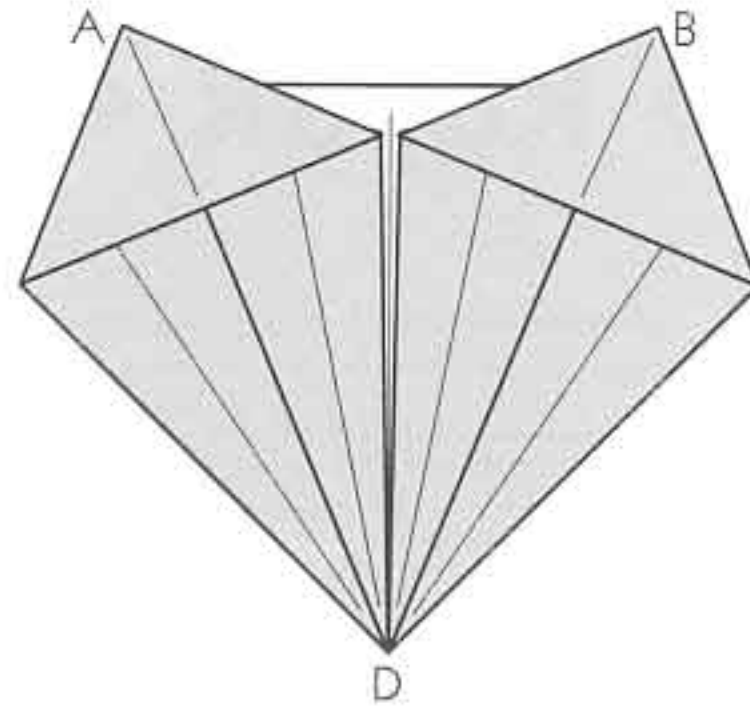

7 Turn over the model.

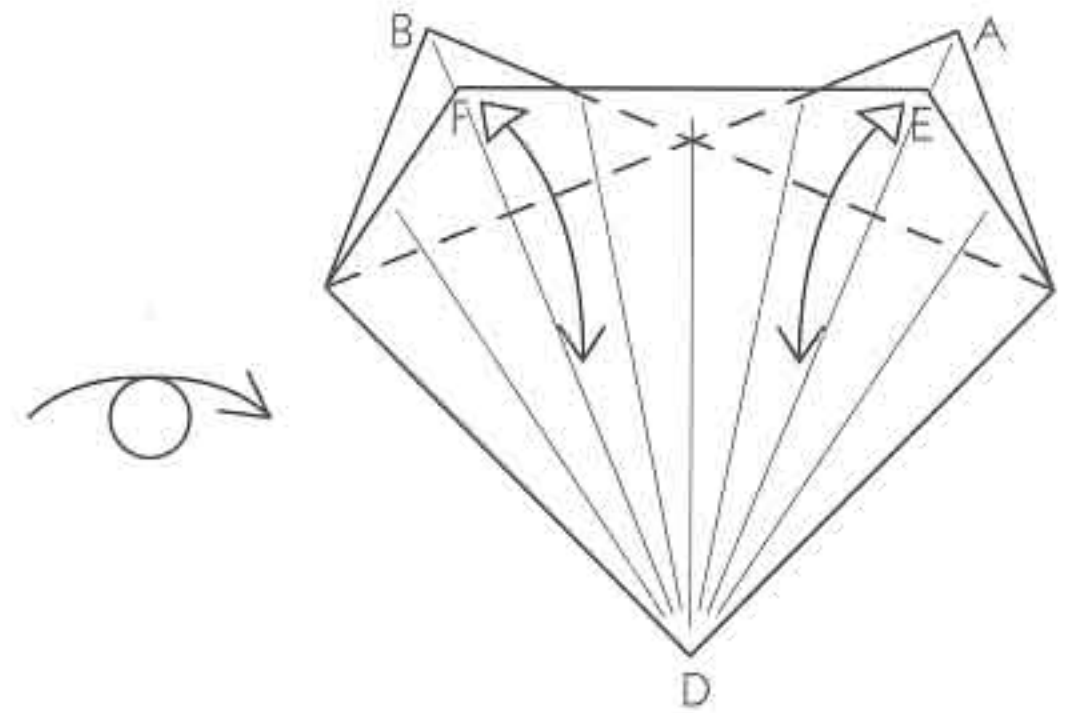

8 Fold down corner F, crease, and unfold. Repeat on the right on corner E.

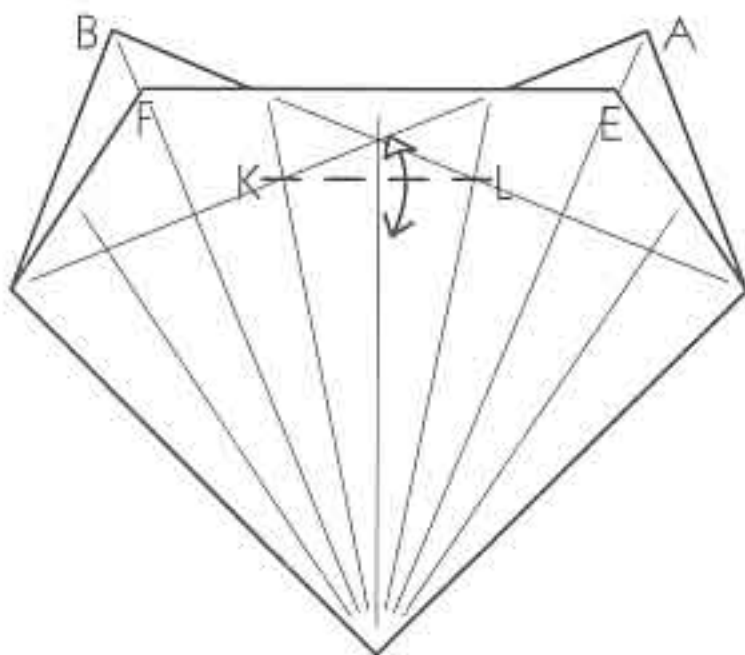

9 Make a crease that connects points K and L. Fold through all layers, crease firmly, and unfold.

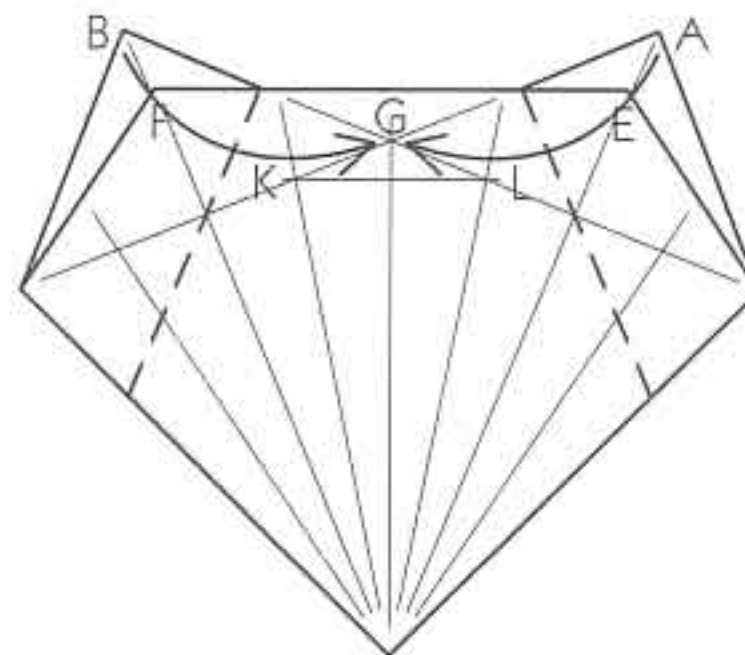

10 Fold point B in to point G, which is the intersection of the two creases you made in step 8. Repeat on the right with point A.

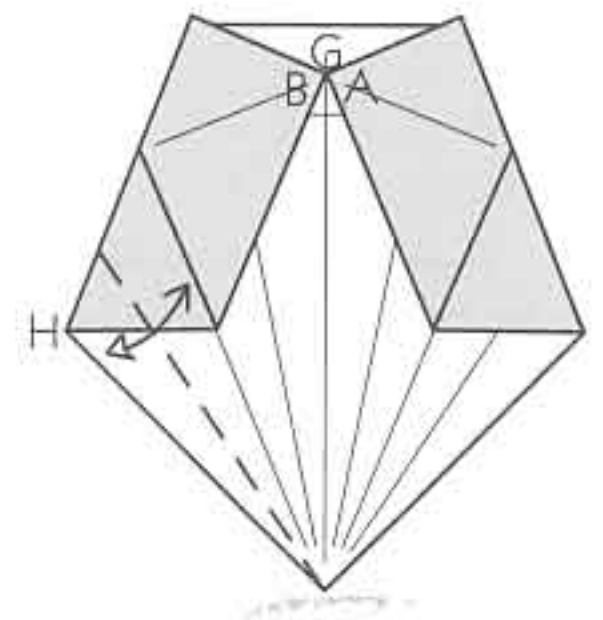

11 Fold corner H in on an existing crease, crease firmly and unfold.

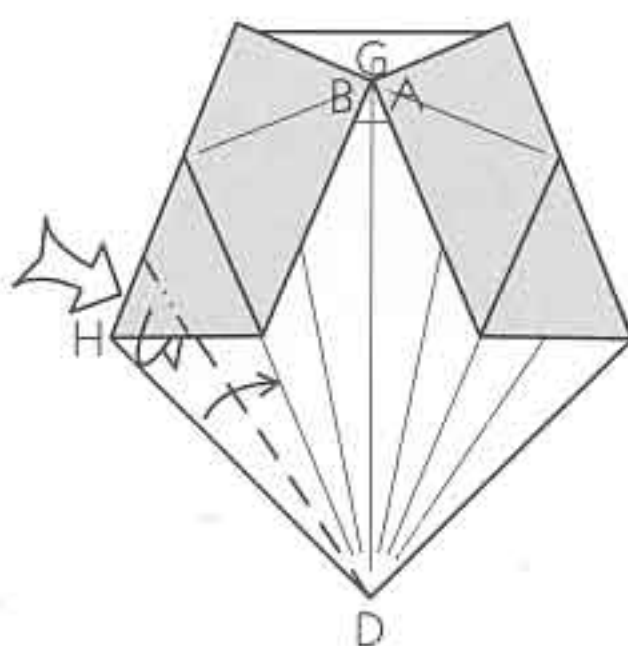

12 Reverse-fold corner H and fold in edge HD on the crease you just made. Do not repeat on the right.

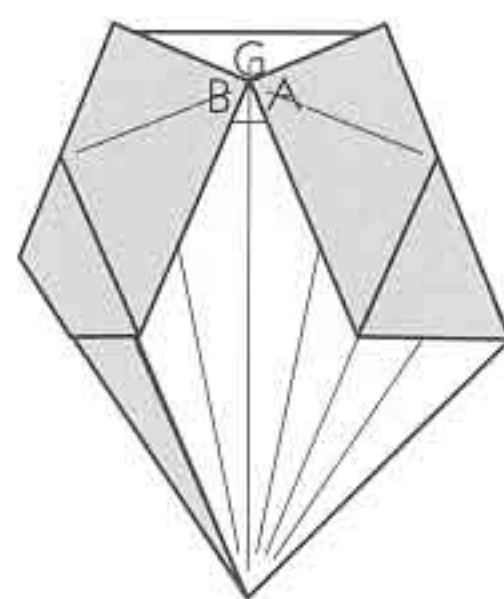

13 Turn over the model.

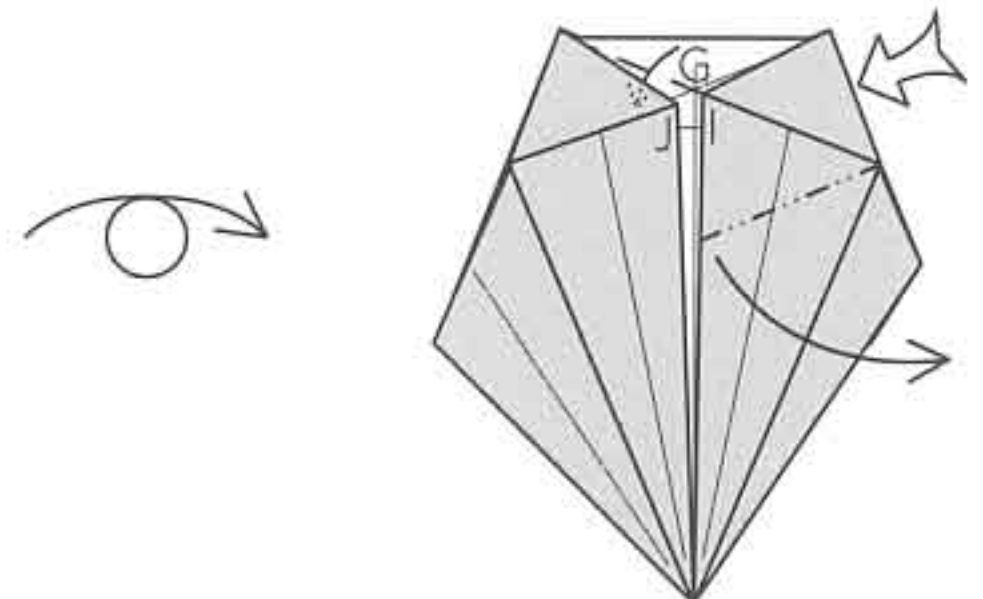

14 Squash-fold the upper right edge. Look at step 15 to see the final position of corner I. Note also that the top edge goes underneath corner J.

kayak

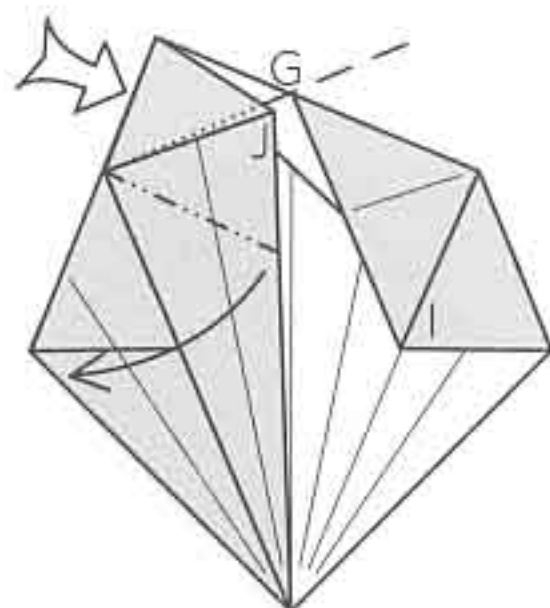

15 Squash-fold the upper left edge in the same way. Note that corner I landed on an existing crease; corner J does the same.

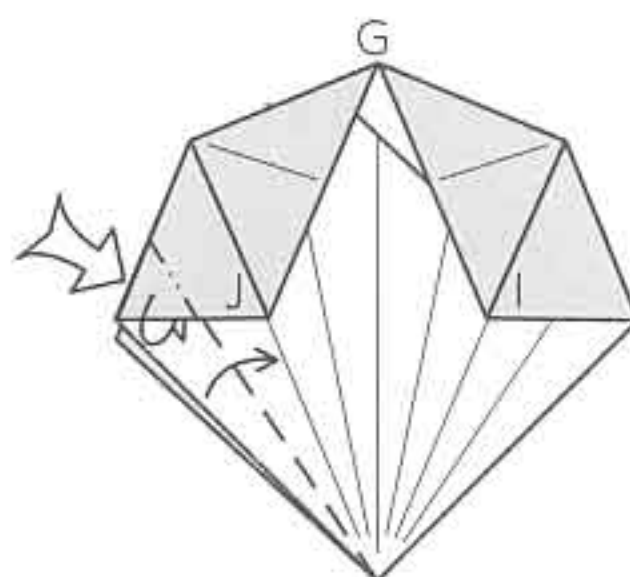

16 Reverse-fold the edge just as you did in steps 11–12. Do not repeat on the right.

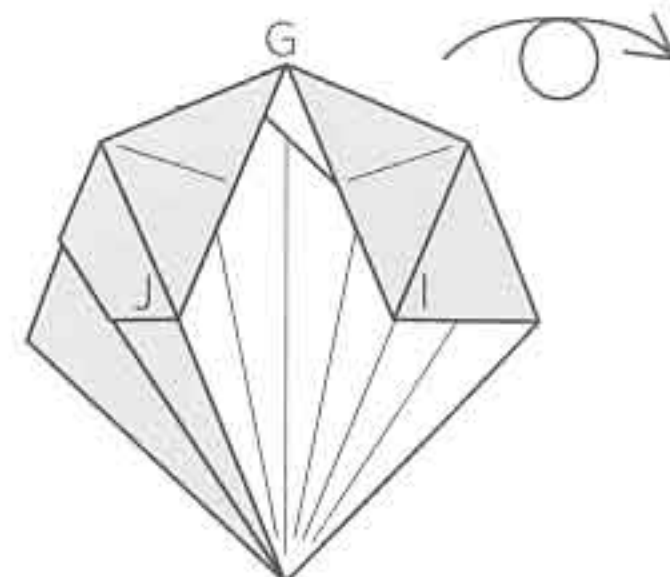

17 Turn over the model.

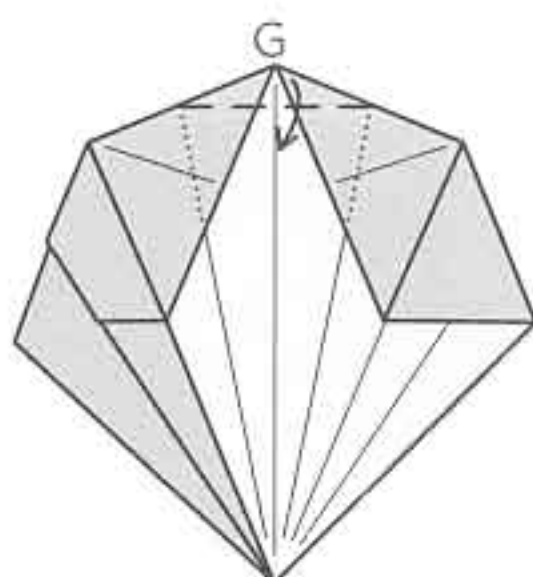

18 Carefully fold down the thick point on the crease you made in step 9.

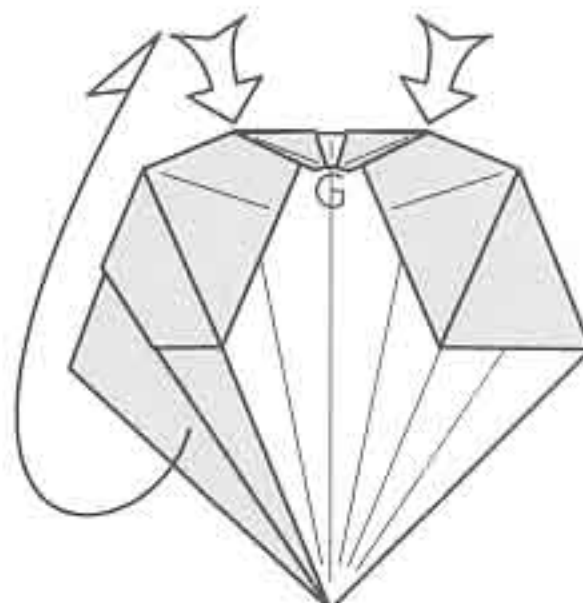

19 Fold the rear layer upward, pushing down on the two corners; the model will not lie flat.

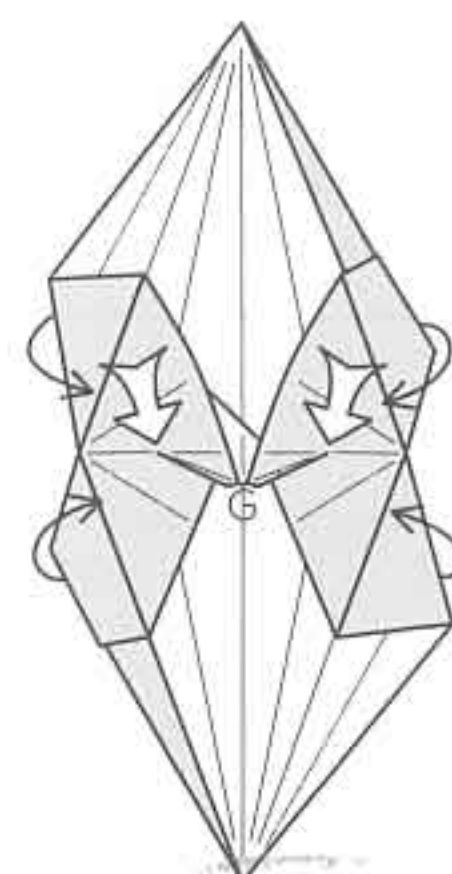

20 Push down on the two corners shown and bring the edges toward you; the model “pops” inside-out. It should end up with the bulge away from you.

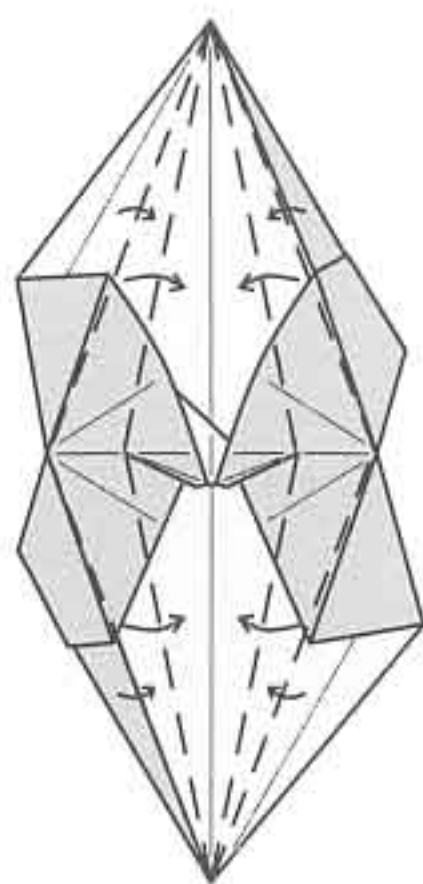

21 Crease each of the valley folds sharply through all layers.

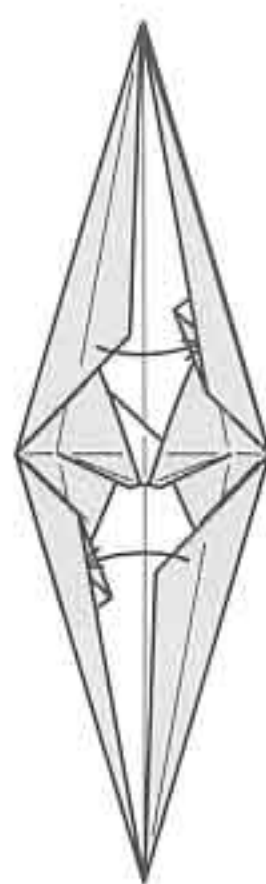

22 Tuck the wider flap on each side into the pocket on the other side.

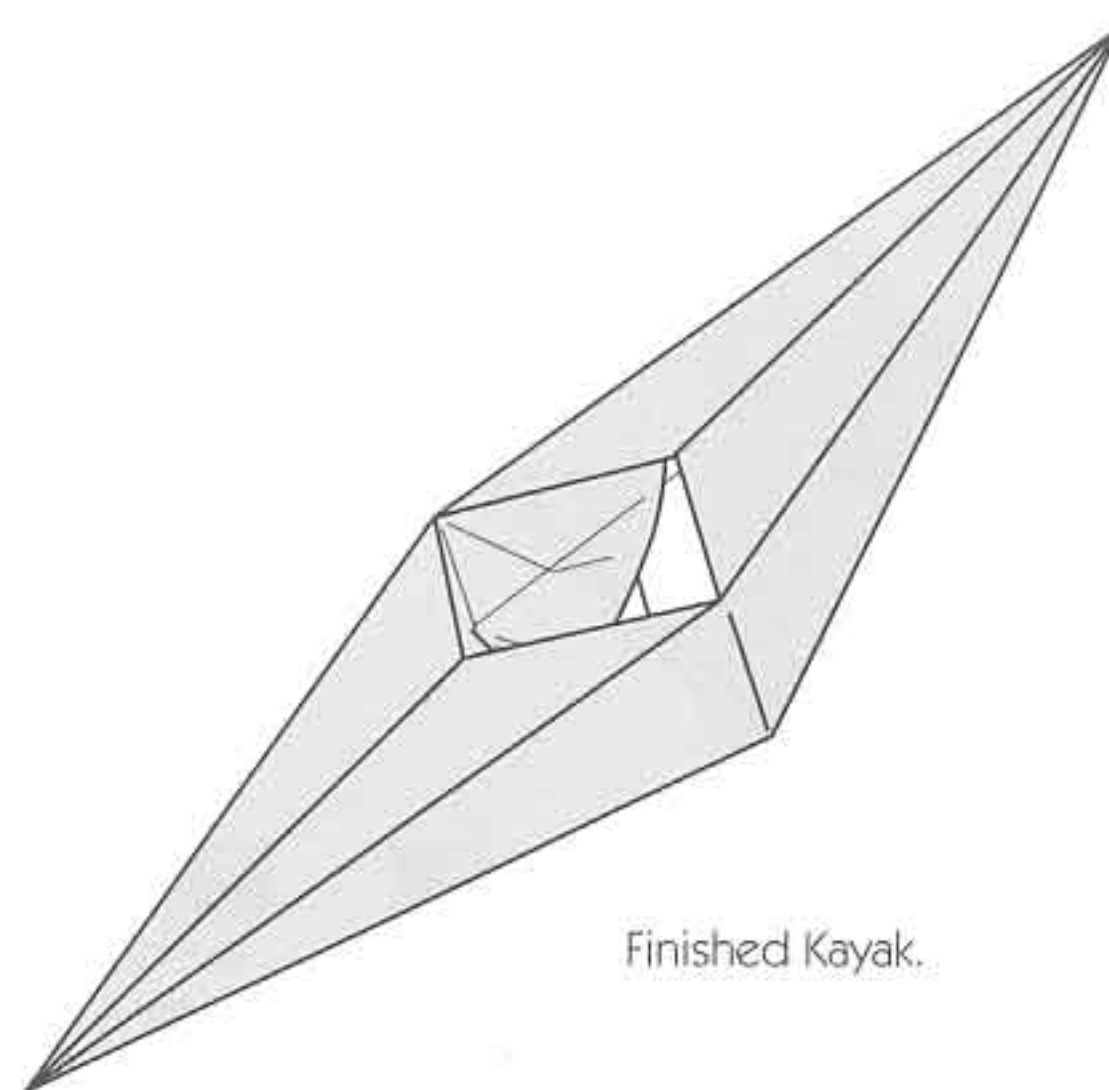

Finished Kayak.

◆ eskimo ◆

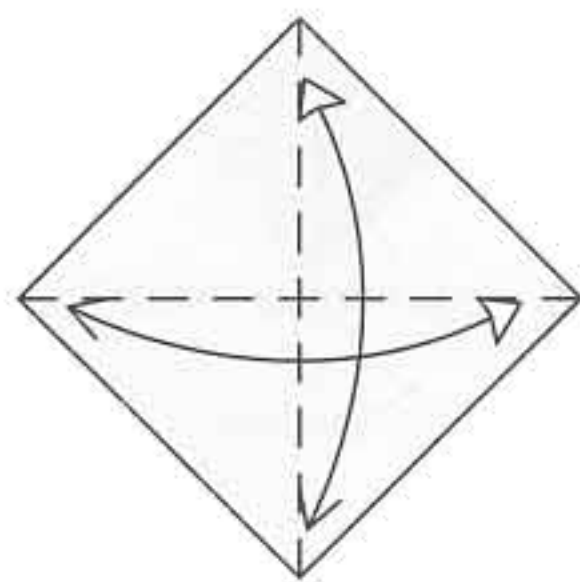

1 Begin with the colored side up. Crease both diagonals. Then turn the paper over.

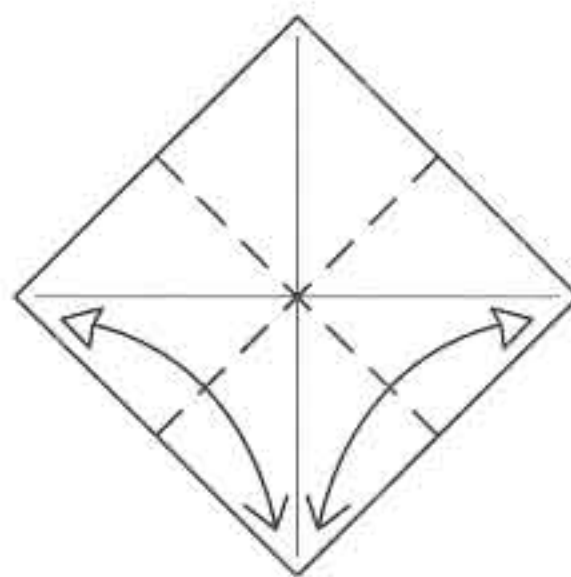
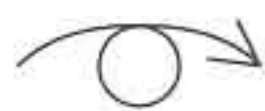

2 Fold the paper in half along the other two directions and unfold.

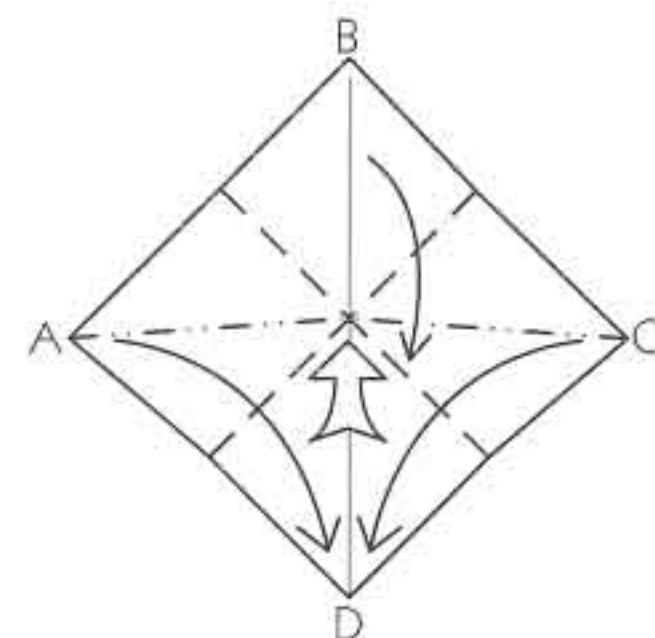

3 Push in the center of the paper and bring corners A, B, and C together at the bottom point D.

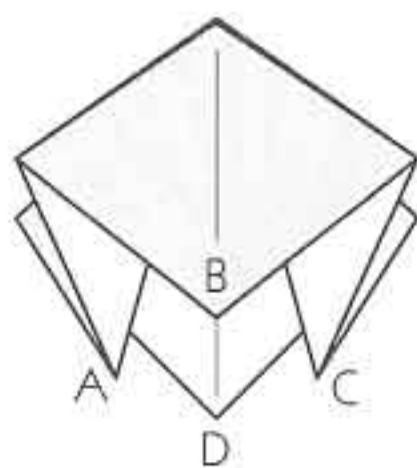

4 Flatten the model.

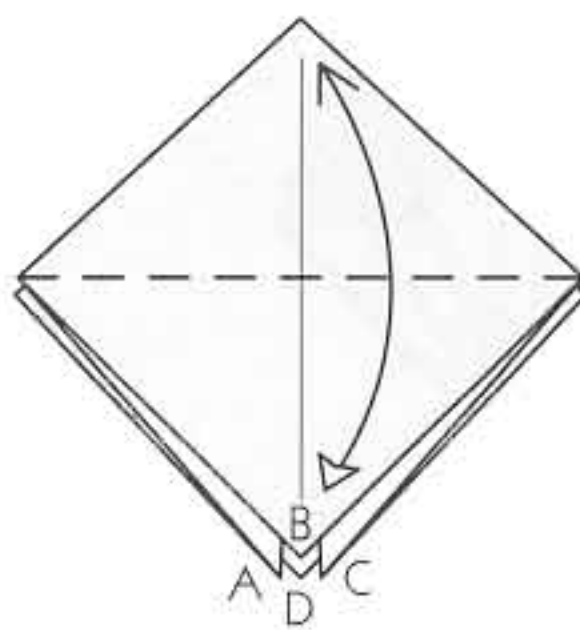

5 Fold point B (single layer only) up to the top and unfold.

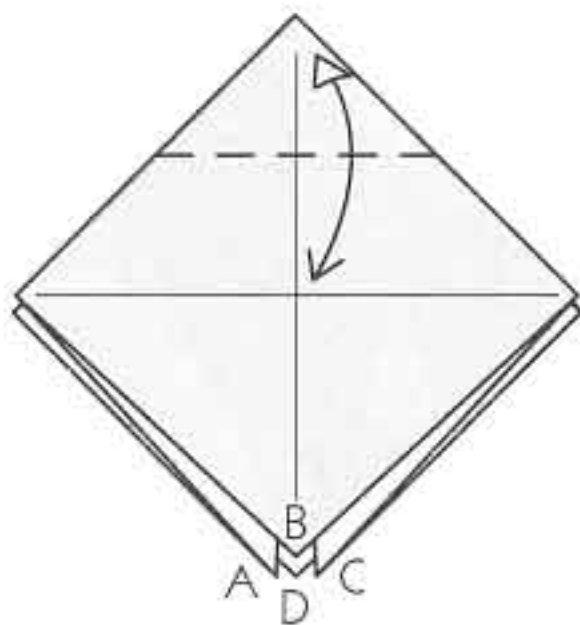

6 Fold the top point down to the crease you just made and unfold.

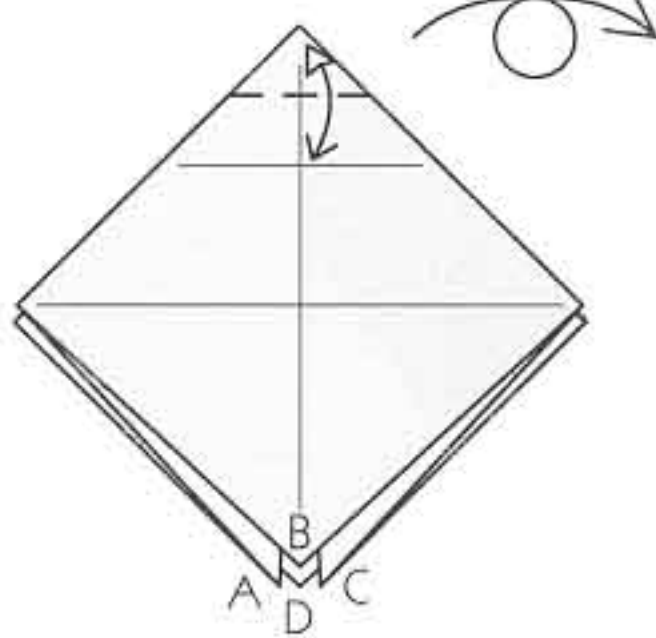

7 Fold the top point down to the crease you just made; crease firmly and unfold. Turn the model over.

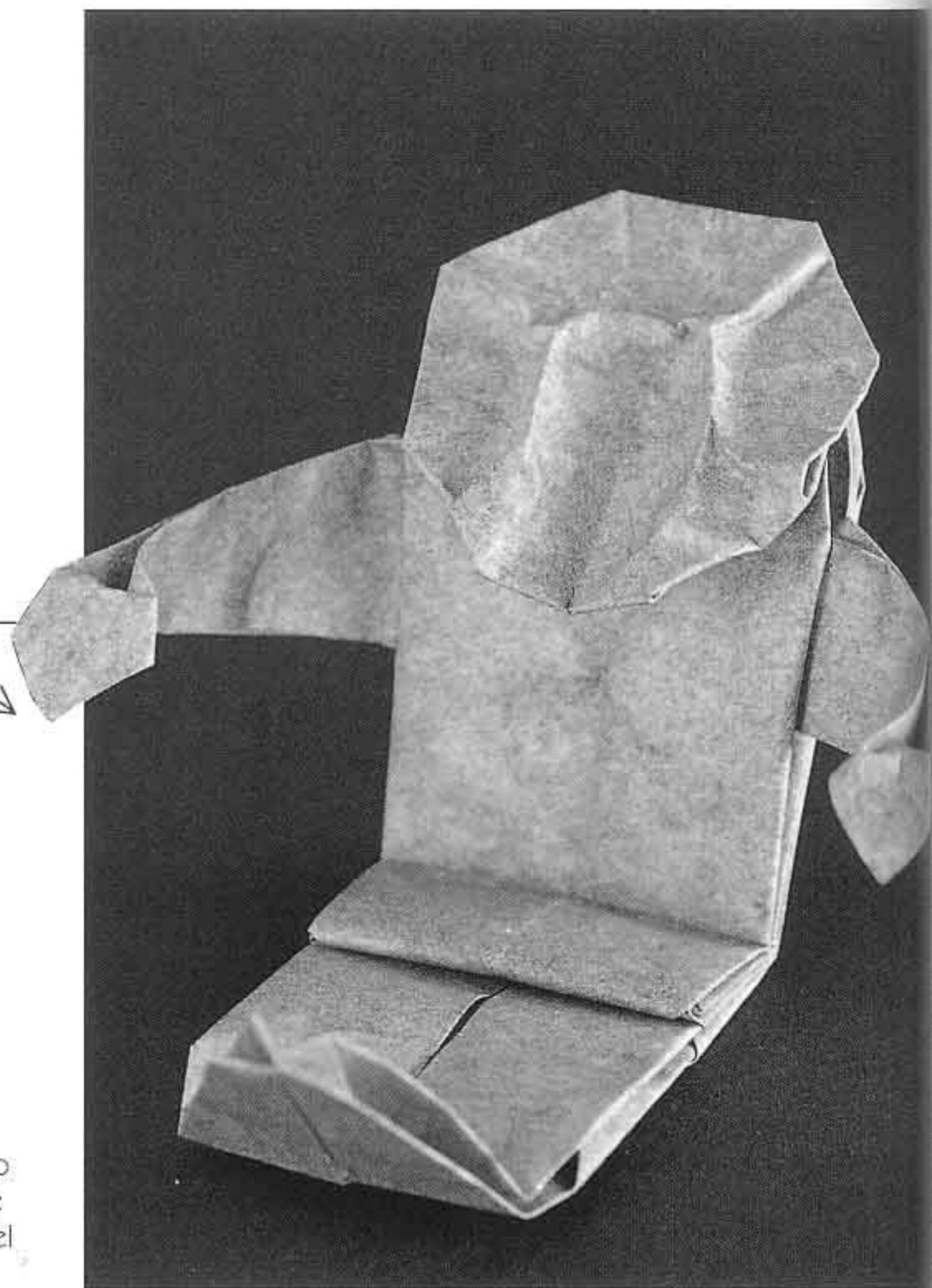

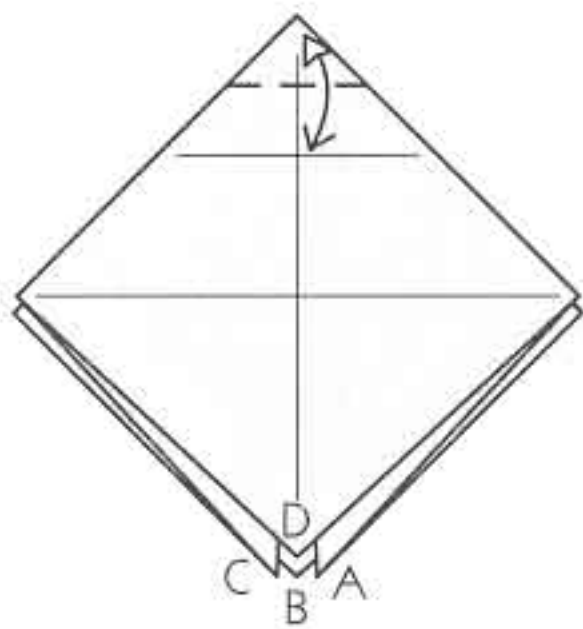

8 Fold the top point down on the same crease; crease firmly and unfold. Do this on both sides of the paper several times until the point folds easily in either direction.

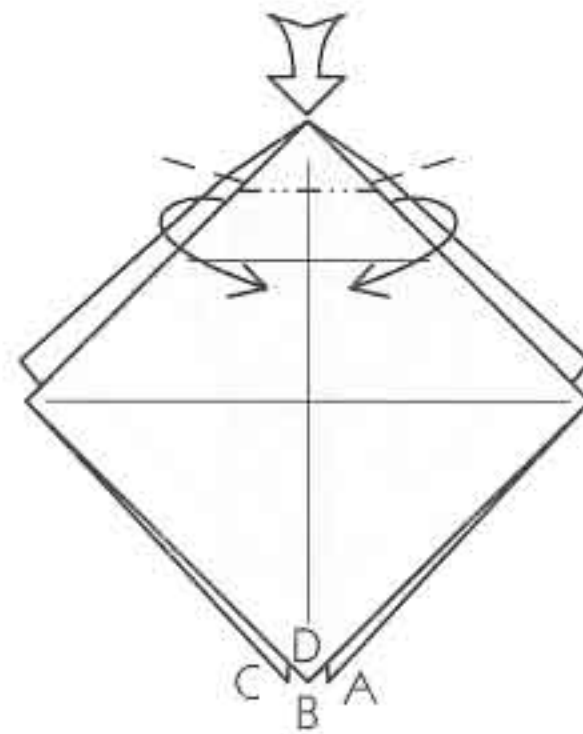

9 Pull the near edges toward you and press down on the top point so that it begins to flatten out. Try to keep points A–D together at the bottom.

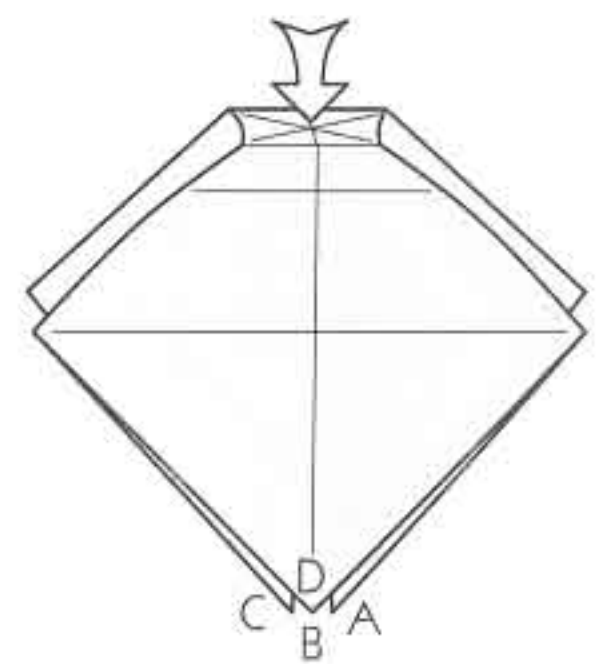

10 Push the flat part down inside the model, changing the direction of some of the creases.

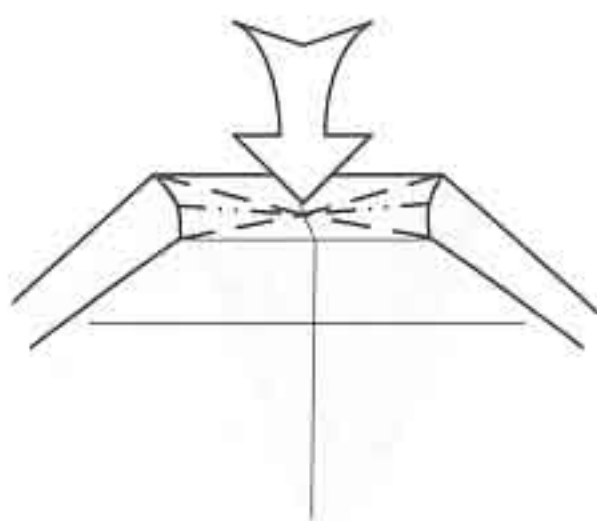

11 Close-up view showing the creases. Push down the middle and flatten the model.

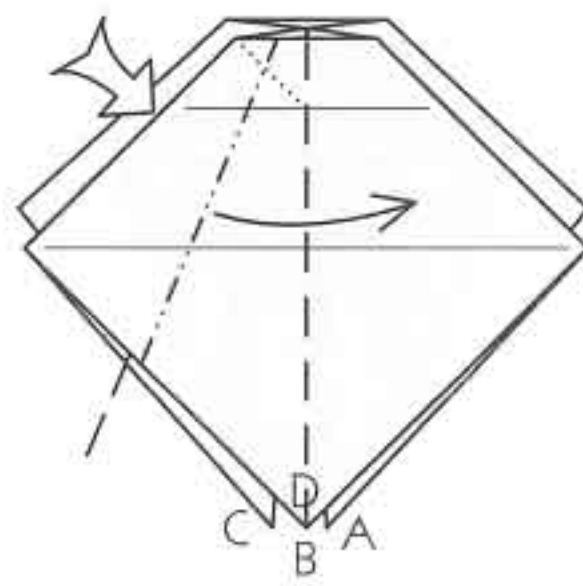

12 Squash-fold the edge by following steps 13–14.

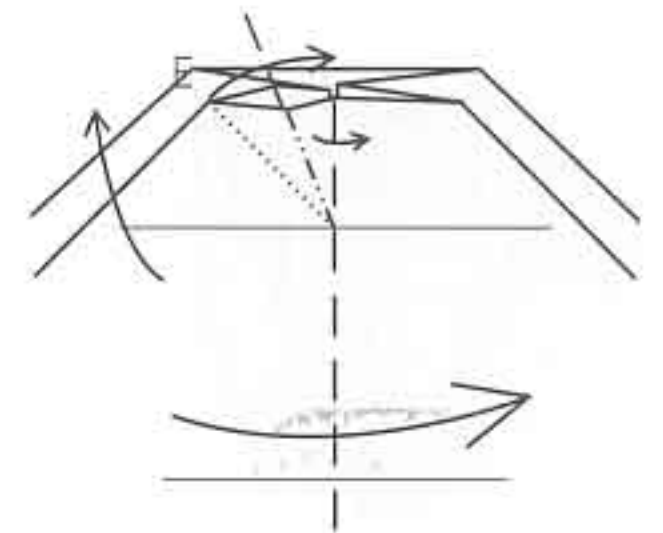

13 First, squash-fold the tiny pocket at the top. It helps to put a pencil or other sharp point inside to spread the layers.

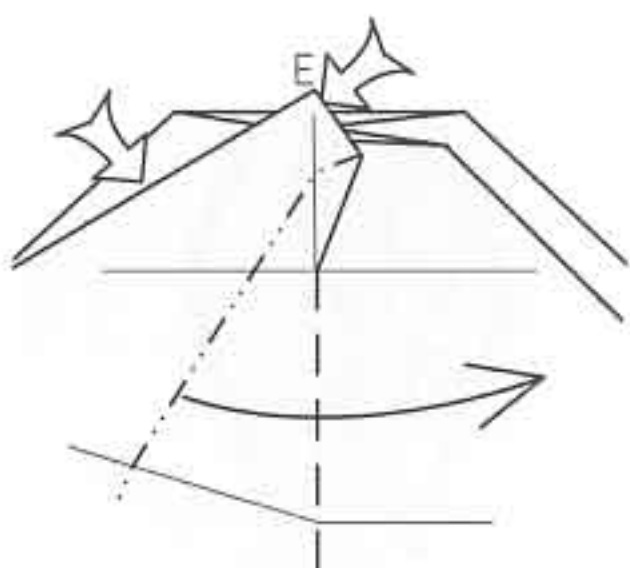

14 Then squash-fold the main edge. point-E disappears in the process. The left flap will come to the center.

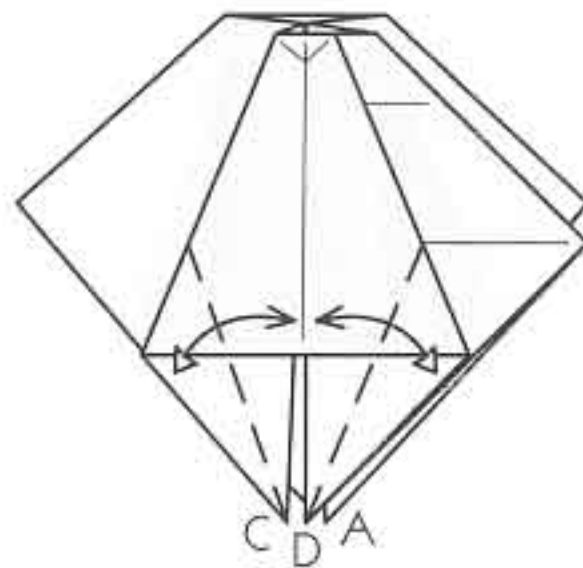

15 Fold a single edge to the center line on each side. Unfold.

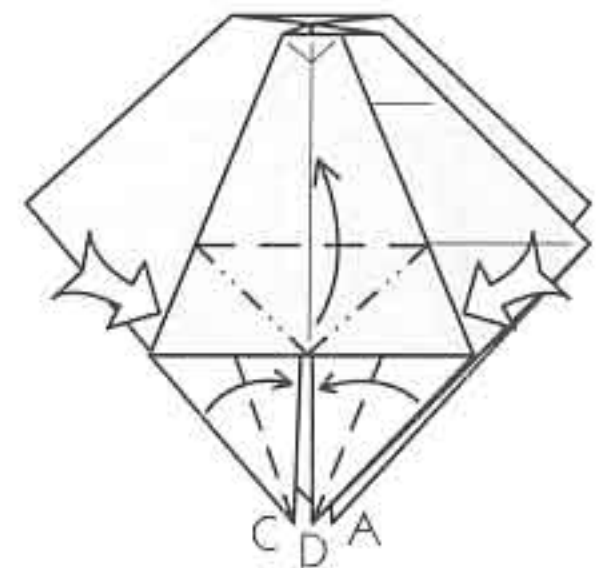

16 Push in the sides and fold the center of the exposed edge up in a petal fold. (It helps to pre-crease the horizontal valley fold.)

Arctic ice

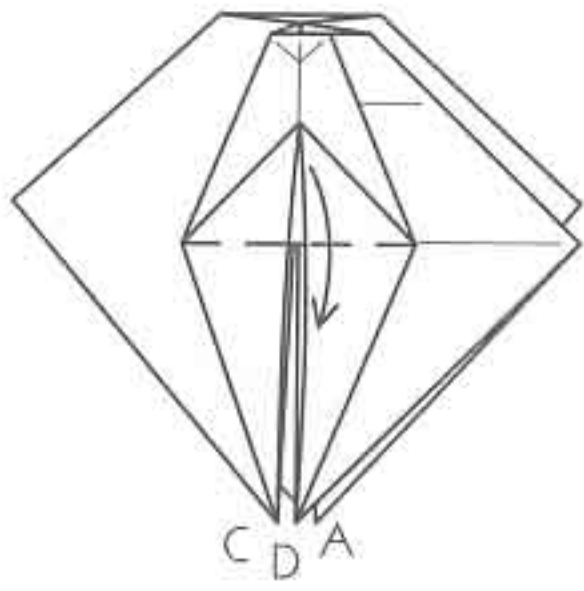

17 Fold the small point back down.

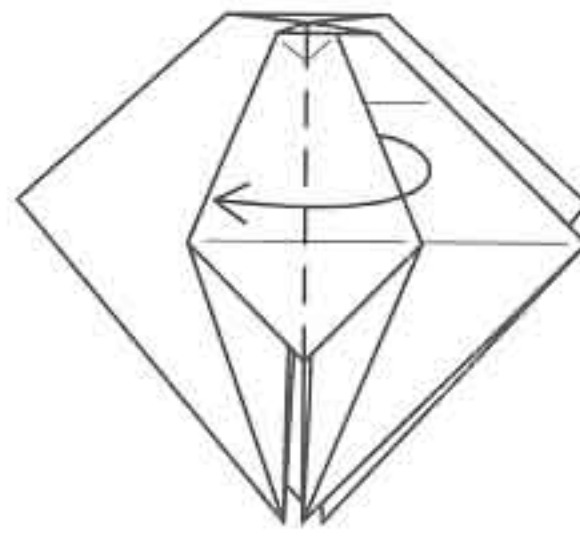

18 Fold one narrow layer to the left.

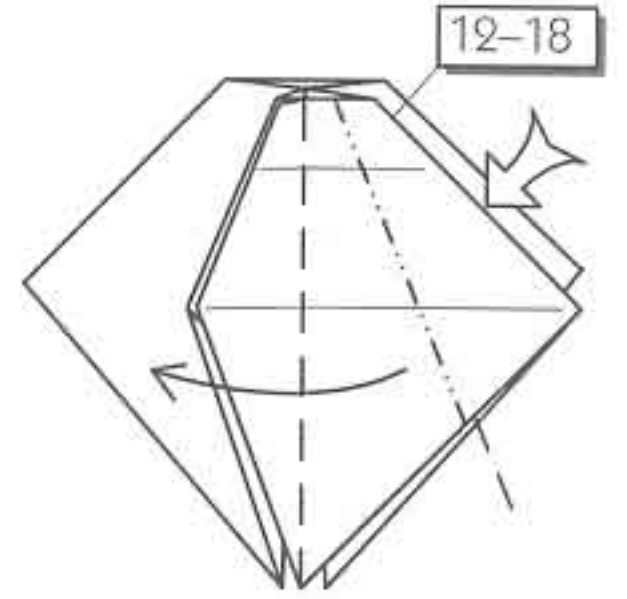

19 Repeat the squash and petal folds of steps 12–18 on the right and on both flaps behind.

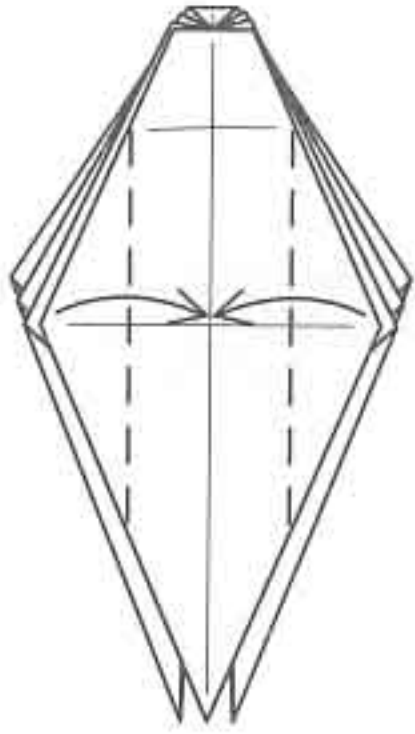

20 Fold in one corner to the center line on each side.

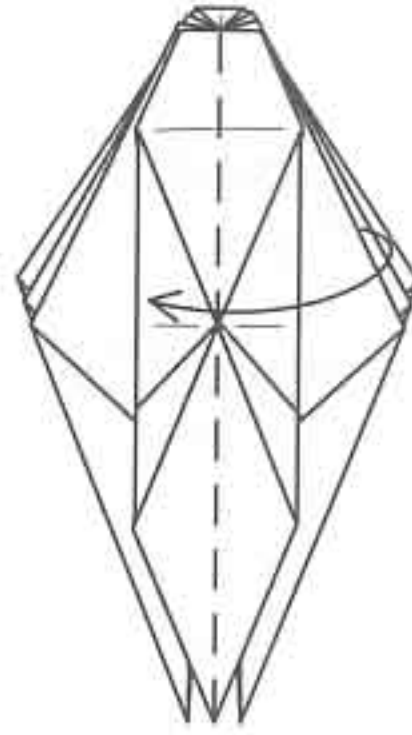

21 Fold one narrow layer and one wide layer to the left.

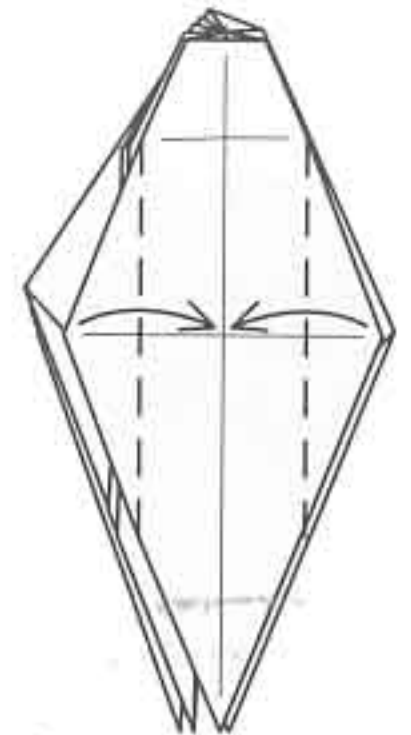

22 Fold in one corner on each side to the center line.

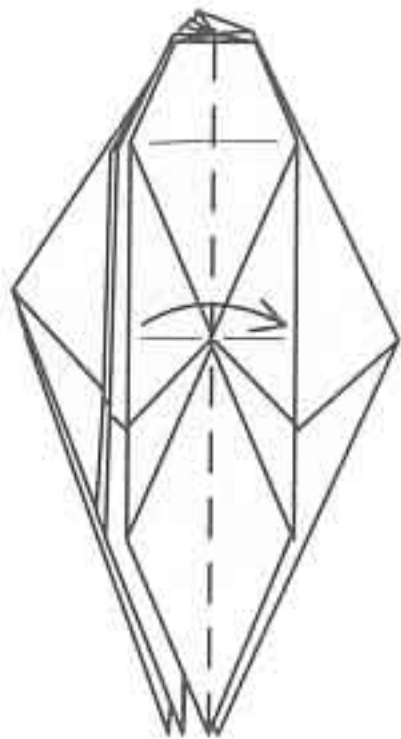

23 Fold one layer to the right.

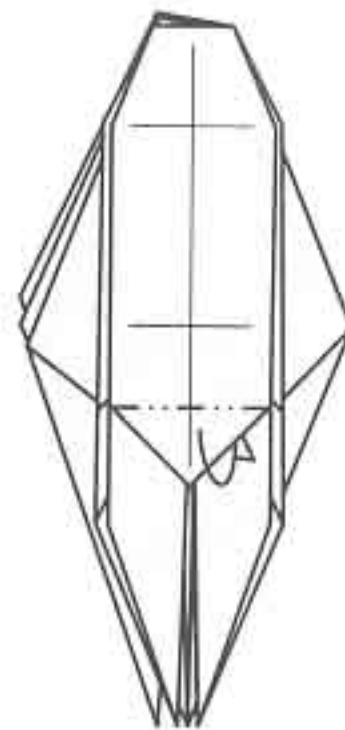

24 Tuck the point underneath and turn the model over.

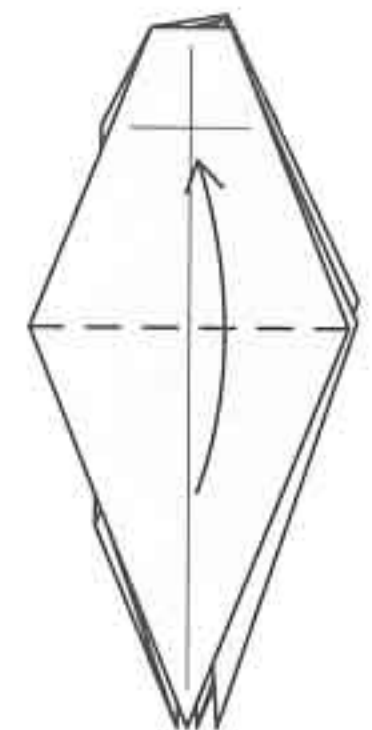
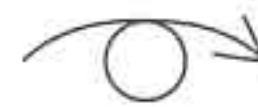

25 Fold one point up.

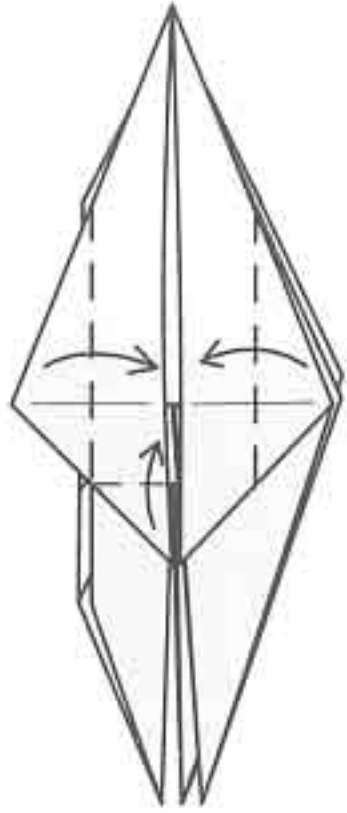

26 Fold in one corner on each side and fold up the left point on the bottom.

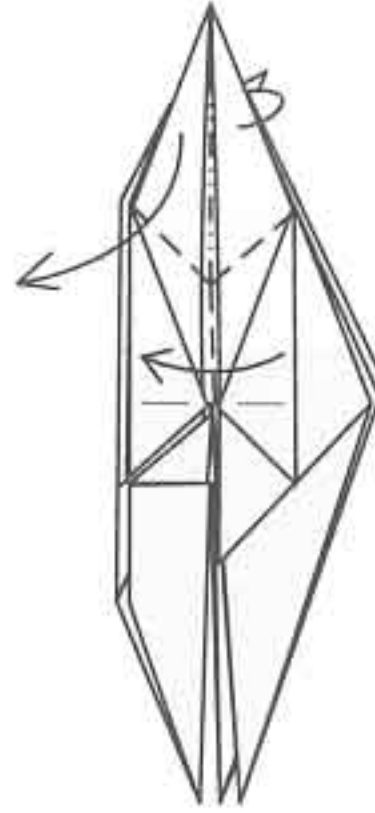

27 Fold one layer to the left while you fold down the top corner and pinch it in half.

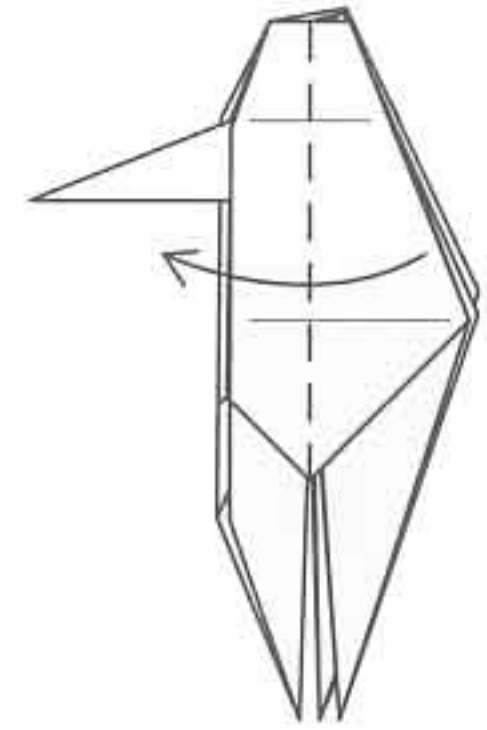

28 Fold one layer to the left.

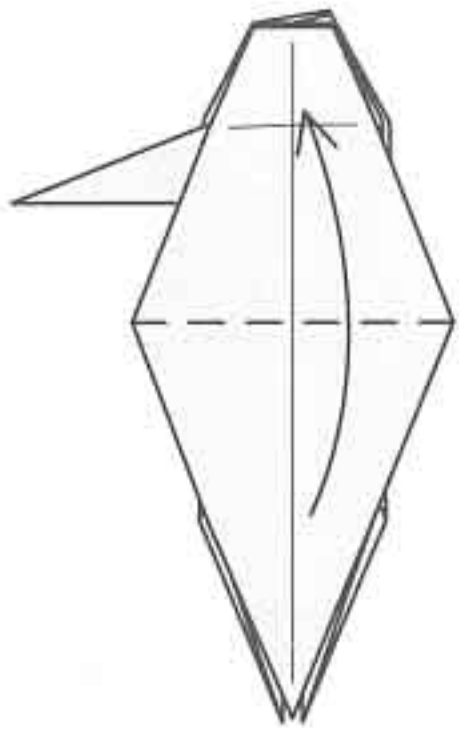

29 Fold up one flap.

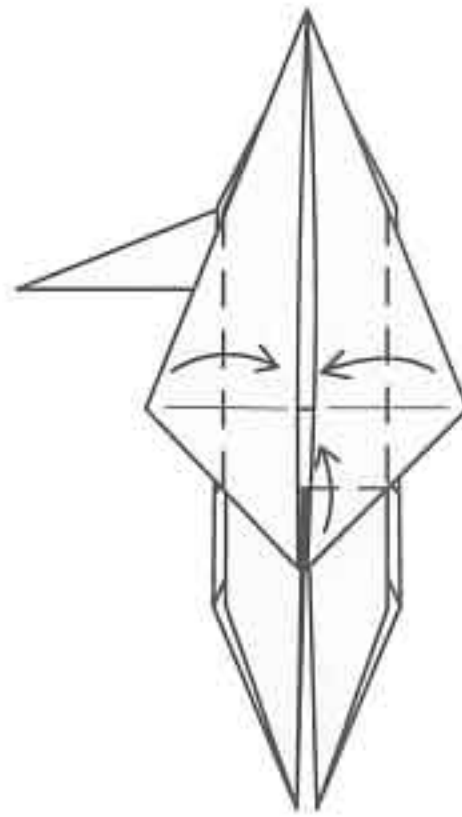

30 Fold in one corner on each side and fold up the right point on the bottom.

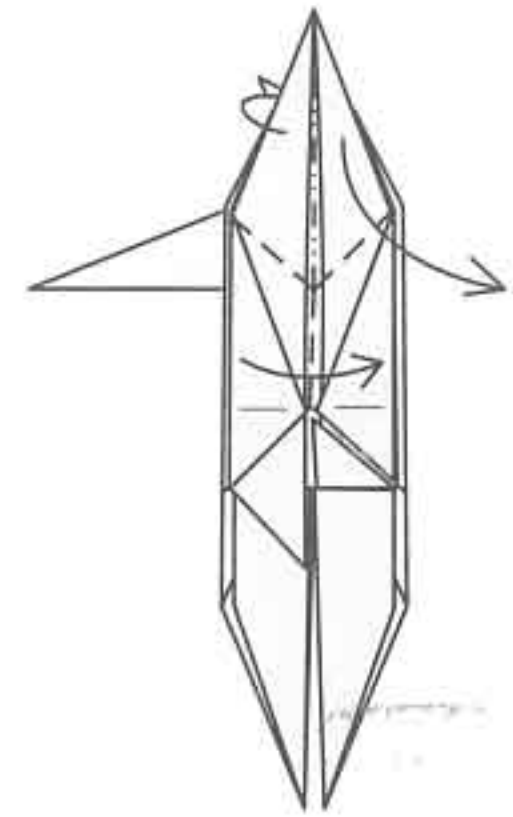

31 Fold one layer to the right while you fold down the top corner and pinch it in half.

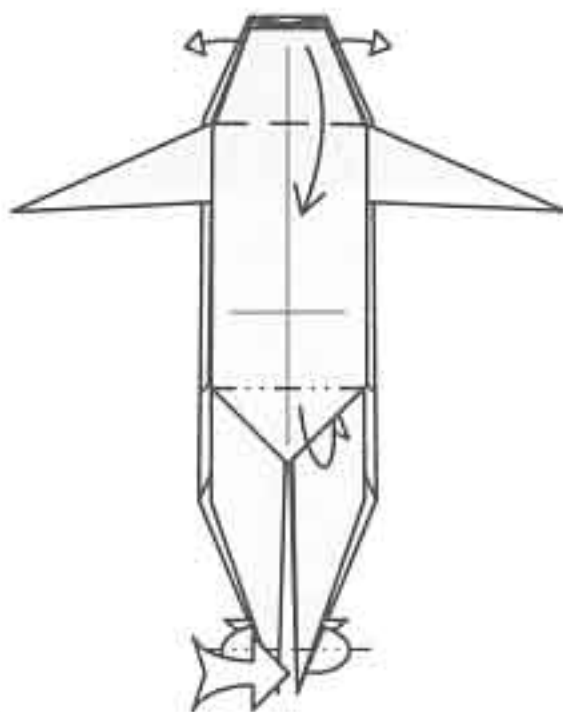

32 Open out the top of the model. Tuck the bottom point up underneath. Reverse-fold the tip of each of the two bottom points.

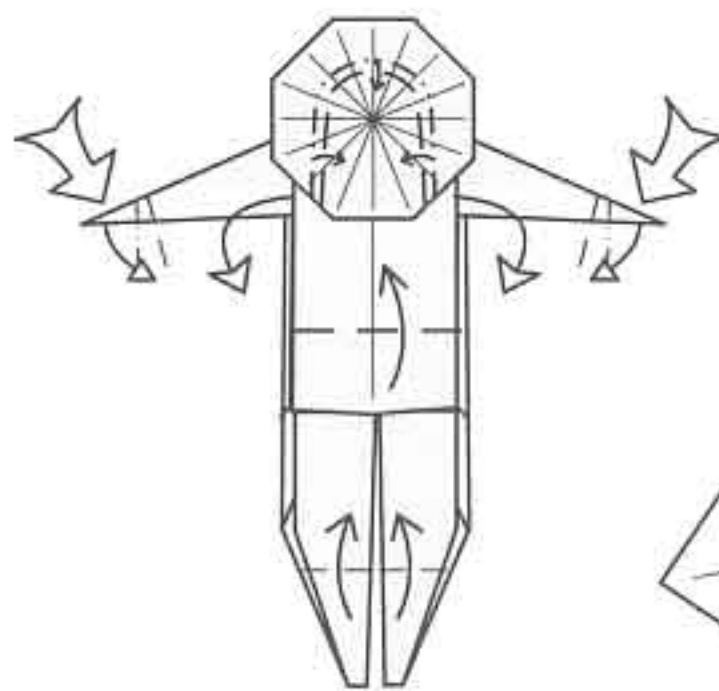

33 Pleat a single layer of paper all the way around the head. Squash-fold the hands and curve the arms around toward the front. Fold the feet up. (If you are putting the Eskimo into a kayak, bend him at the waist.)

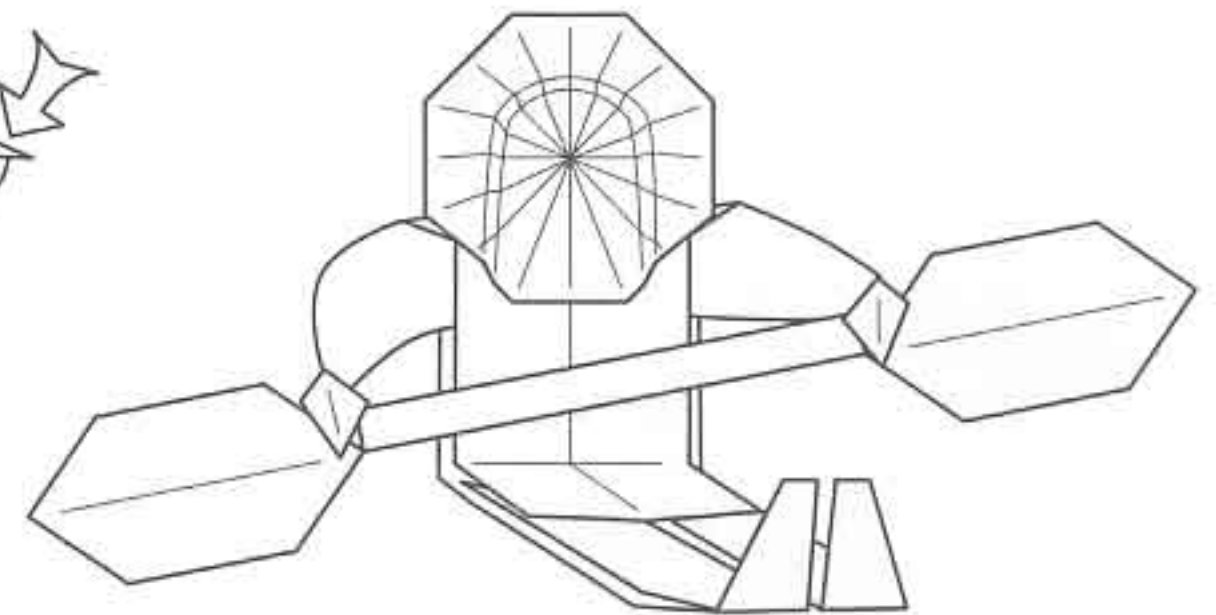

Finished Eskimo.

◆ polar bear ◆

designed by Marc Kirschenbaum

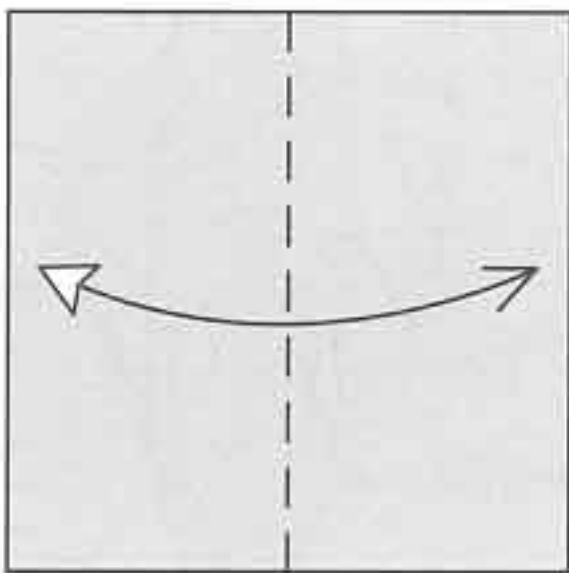
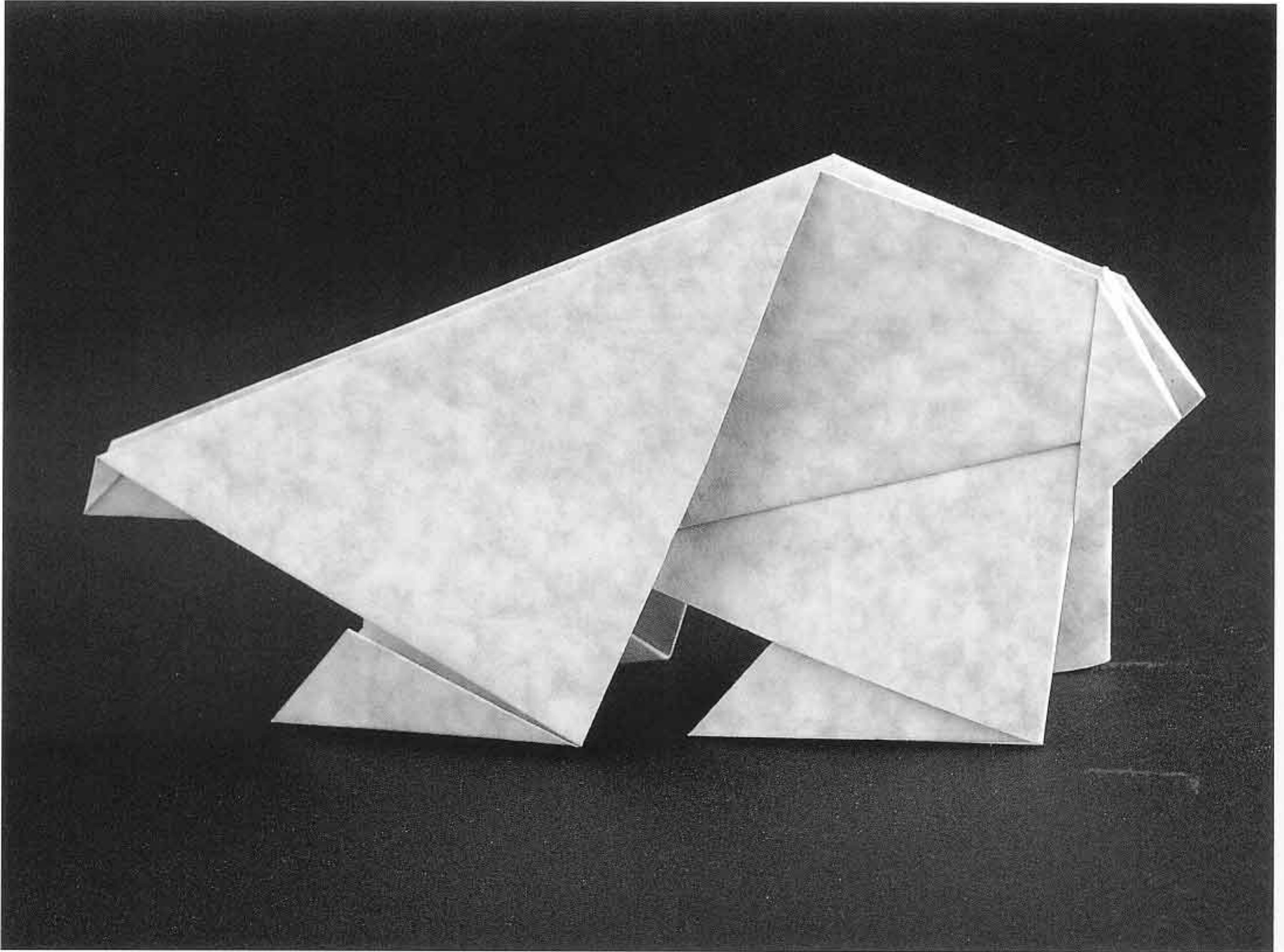

1 Begin with the colored side up. Fold the paper in half and unfold.

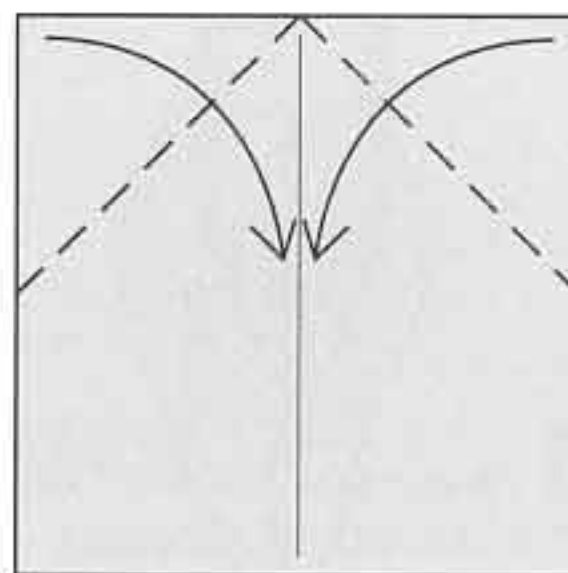

2 Fold down the top edges to meet along the vertical crease.

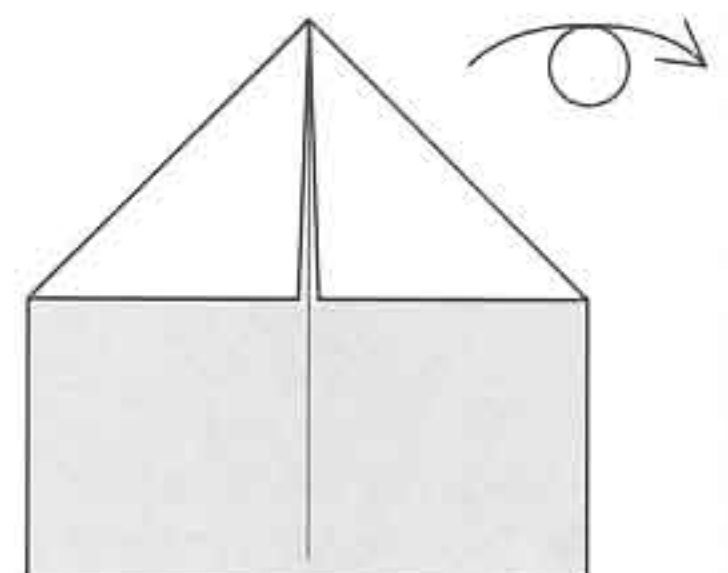

3 Turn over the model.

polar bear

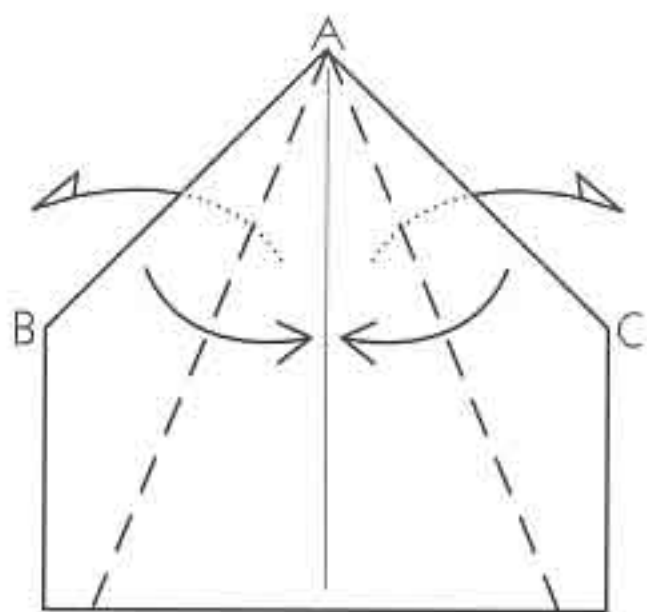

4 Fold in edges AB and AC to meet along the vertical center line; allow the two flaps of paper behind to swing out to the sides.

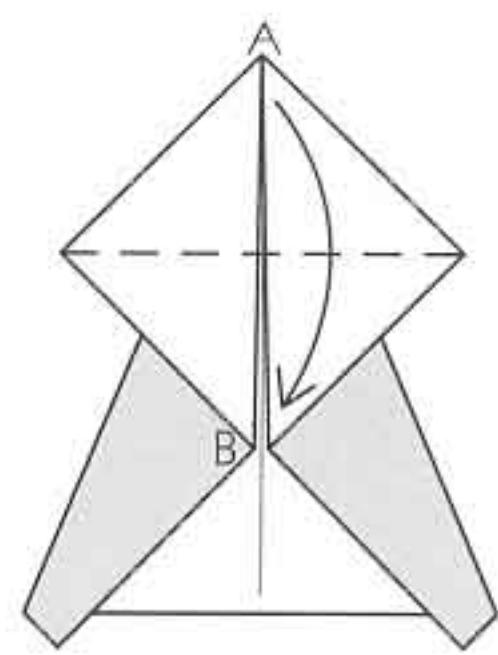

5 Fold point A down to point B.

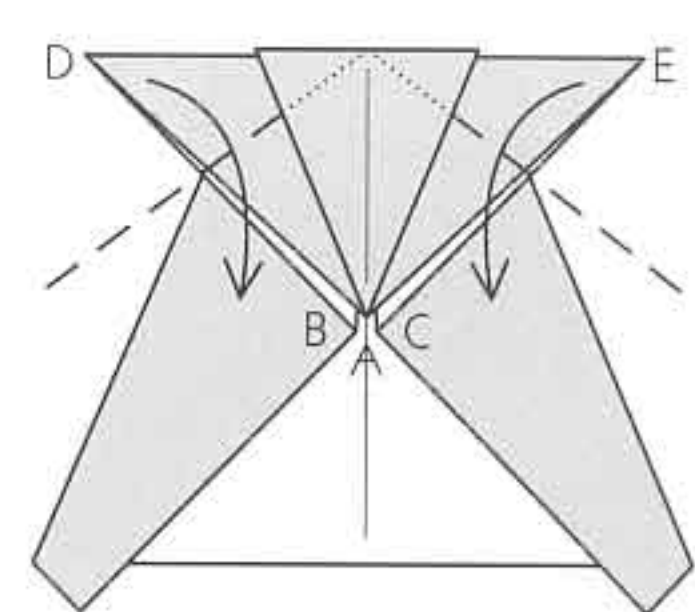

6 Valley-fold corners D and E down. Note that the crease runs all the way up under the pocket, and it hits the edge where two edges come together.

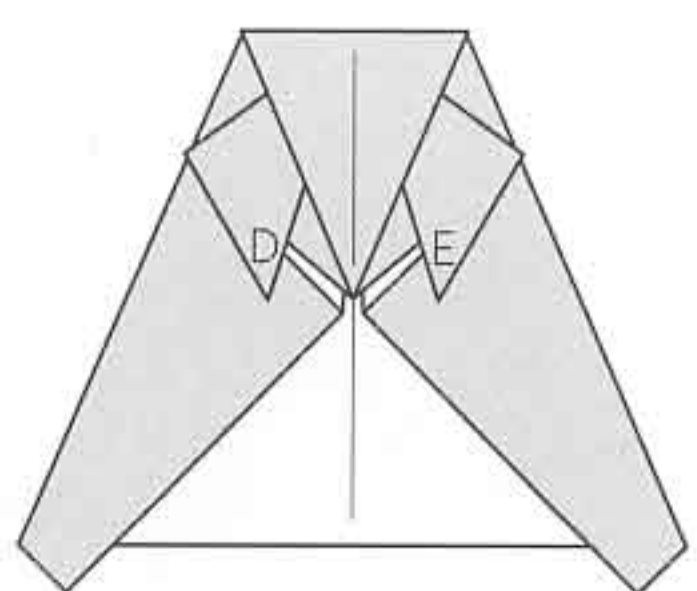

7 Turn the model over.

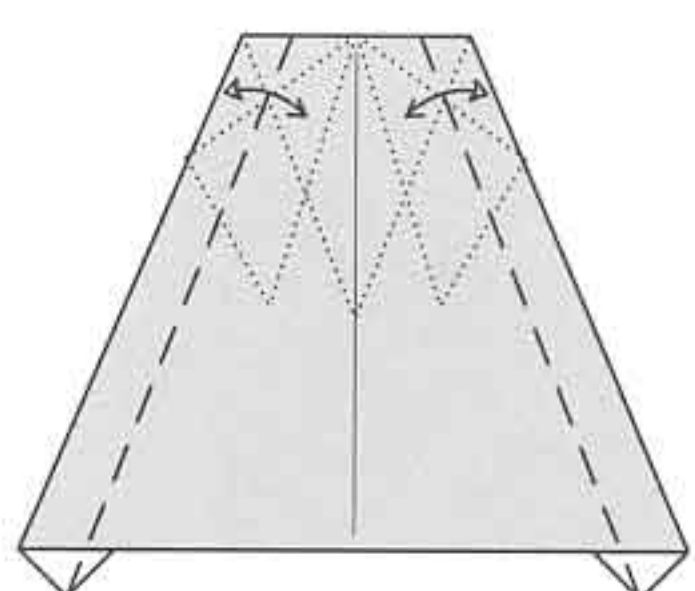
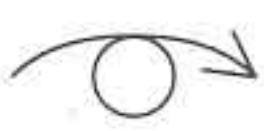

8 Crease lightly with valley folds. Note that near the top of the model, each crease crosses the intersection of two hidden edges.

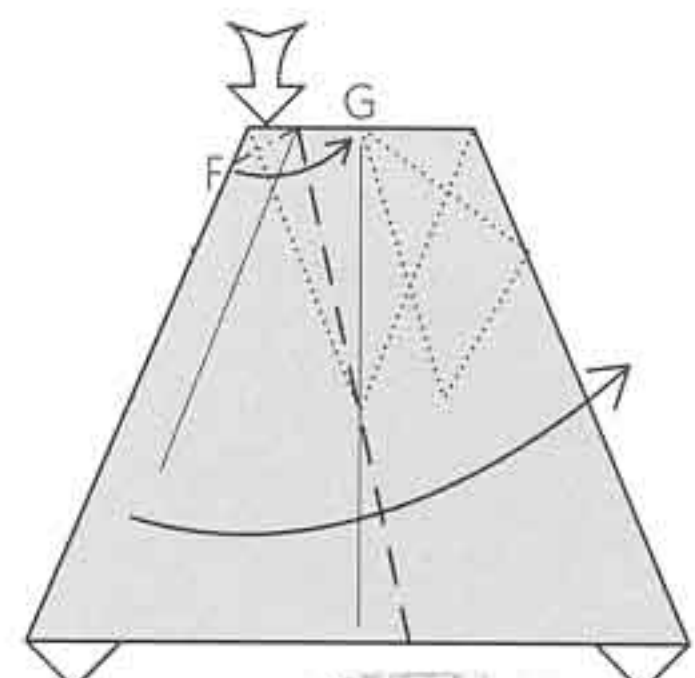

9 Squash-fold the upper left corner and fold the left side up to the right. You should adjust the fold so that point F hits point G.

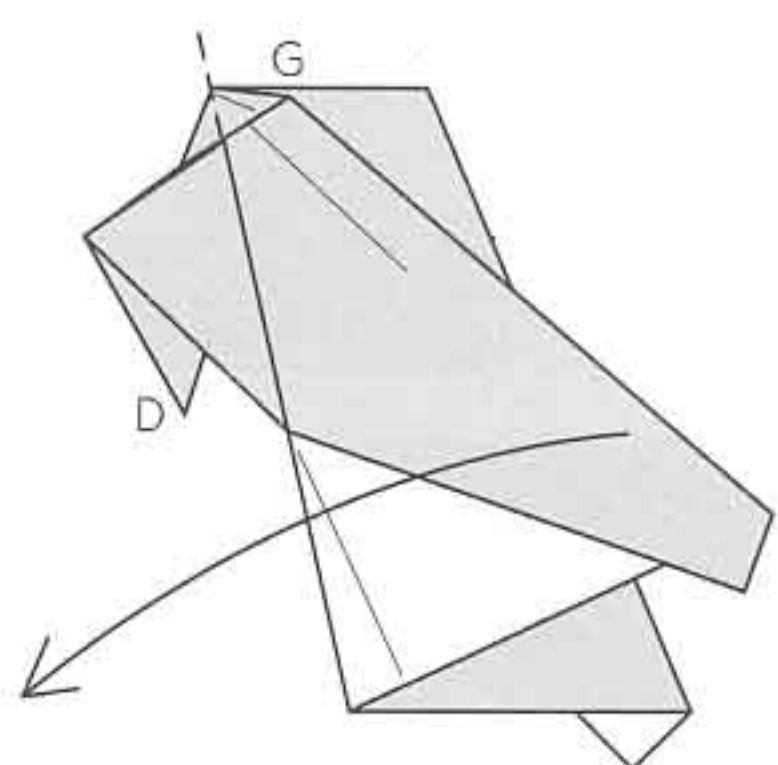

10 Fold the flap back to the left, but keep the squash fold at the top in place.

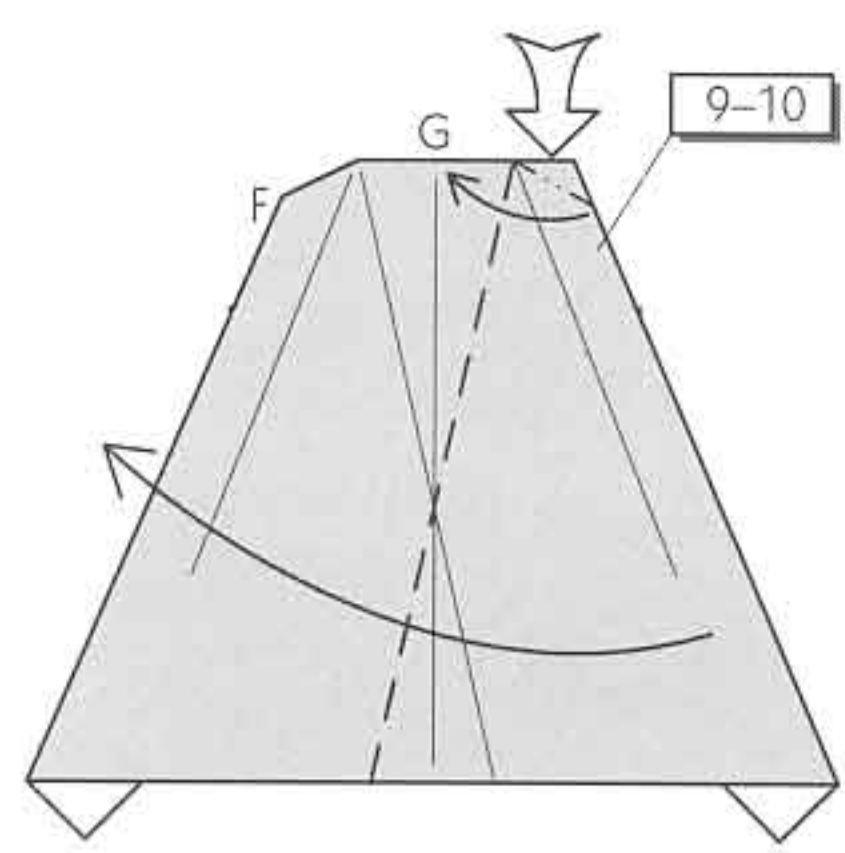

11 Repeat steps 9-10 on the right.

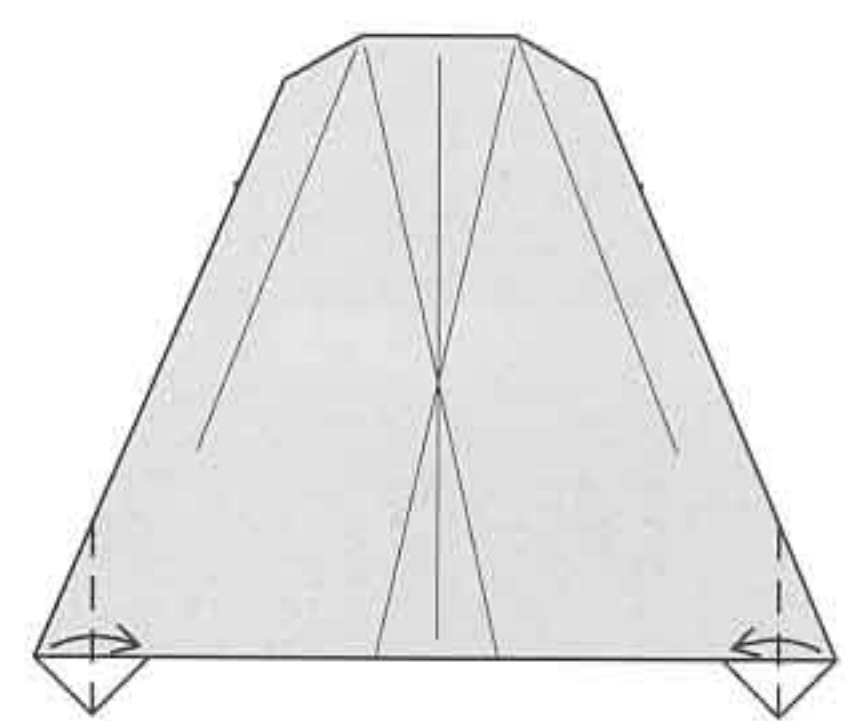

12 Fold the bottom corners in half.

Arctic ice

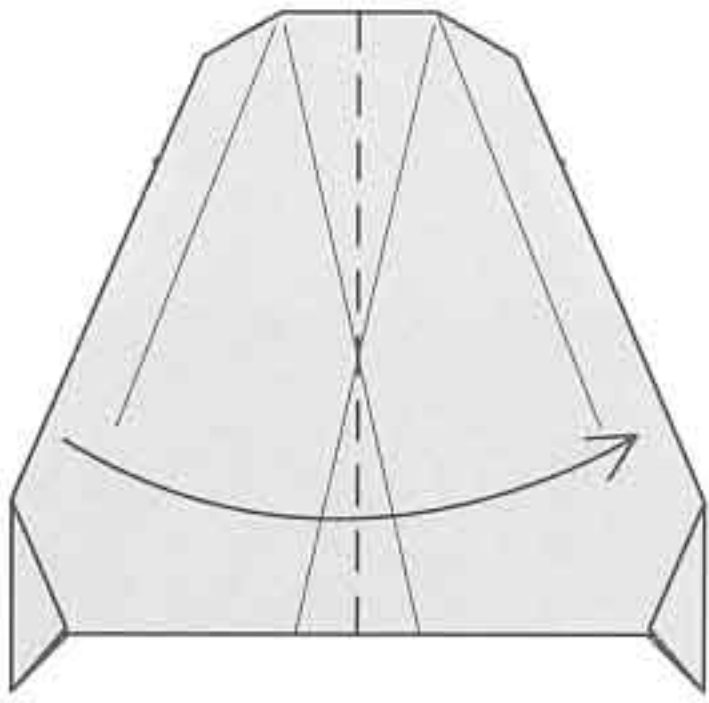

13 Fold the model in half.

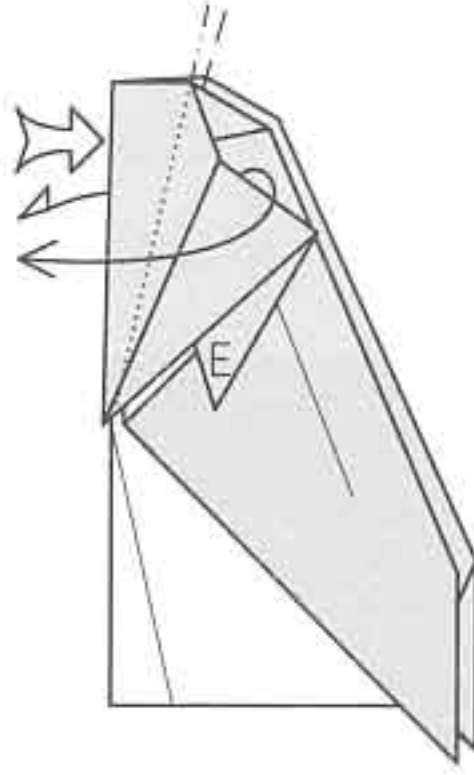

14 Push in the top of the left edge; at the same time, swing points E and D (behind) to the left. Flatten.

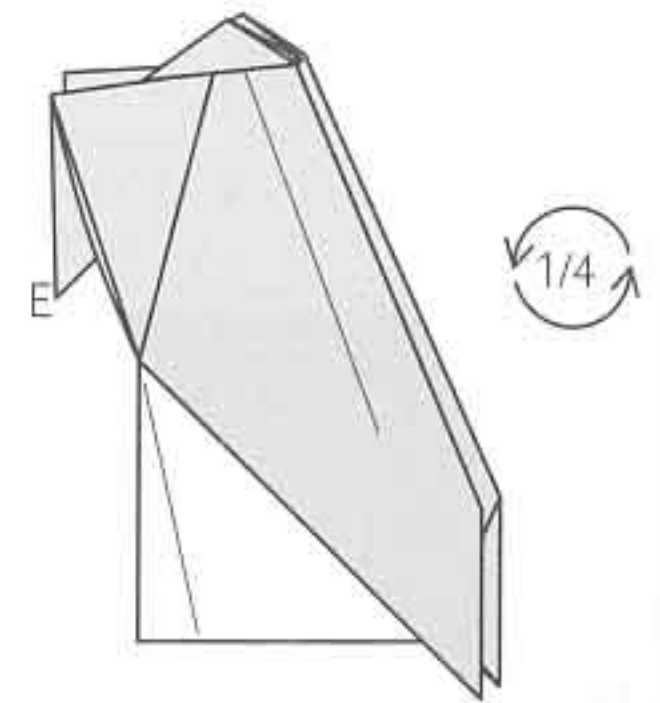

15 Rotate the model 1/4 turn counterclockwise.

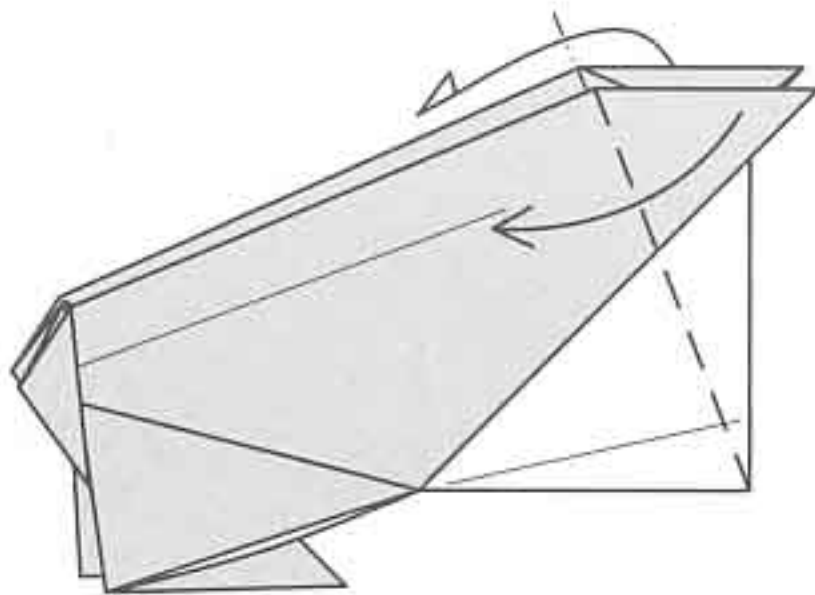

16 Fold one point to the left in front and one to the right behind.

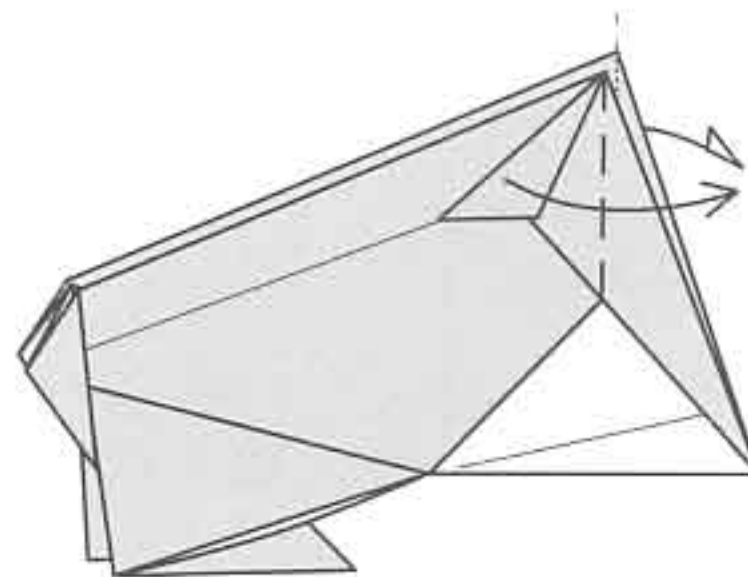

17 Fold one point to the right in front and behind.

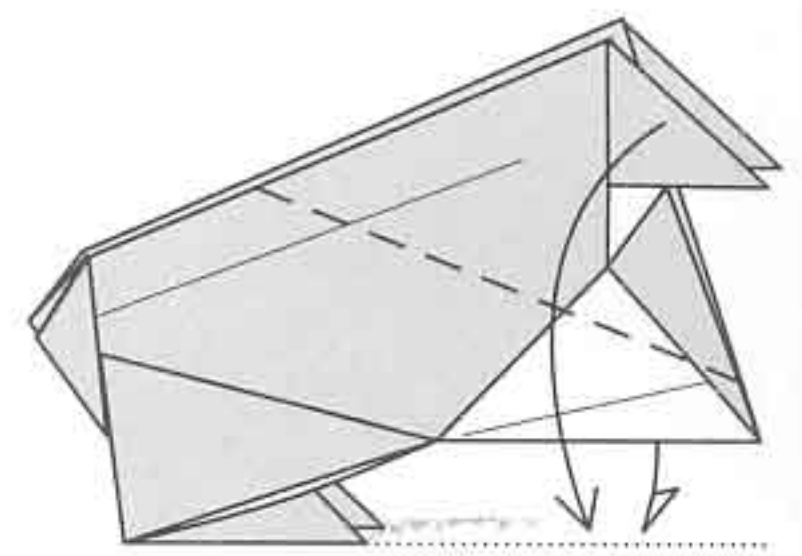

18 Fold down the top edges so that the small flaps (the feet) line up with the rear feet.

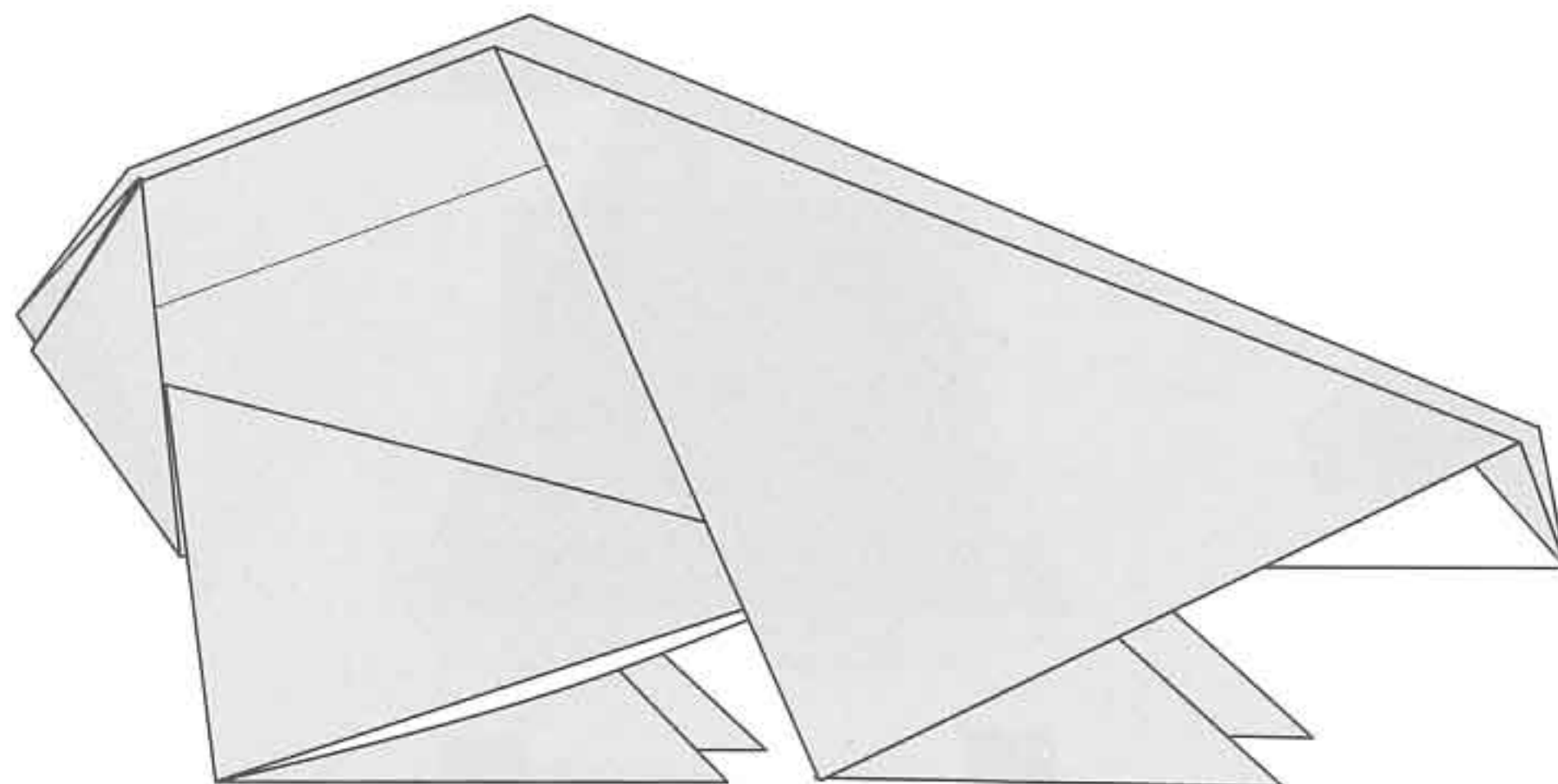

Finished Polar Bear.

◆ Australian forest ◆

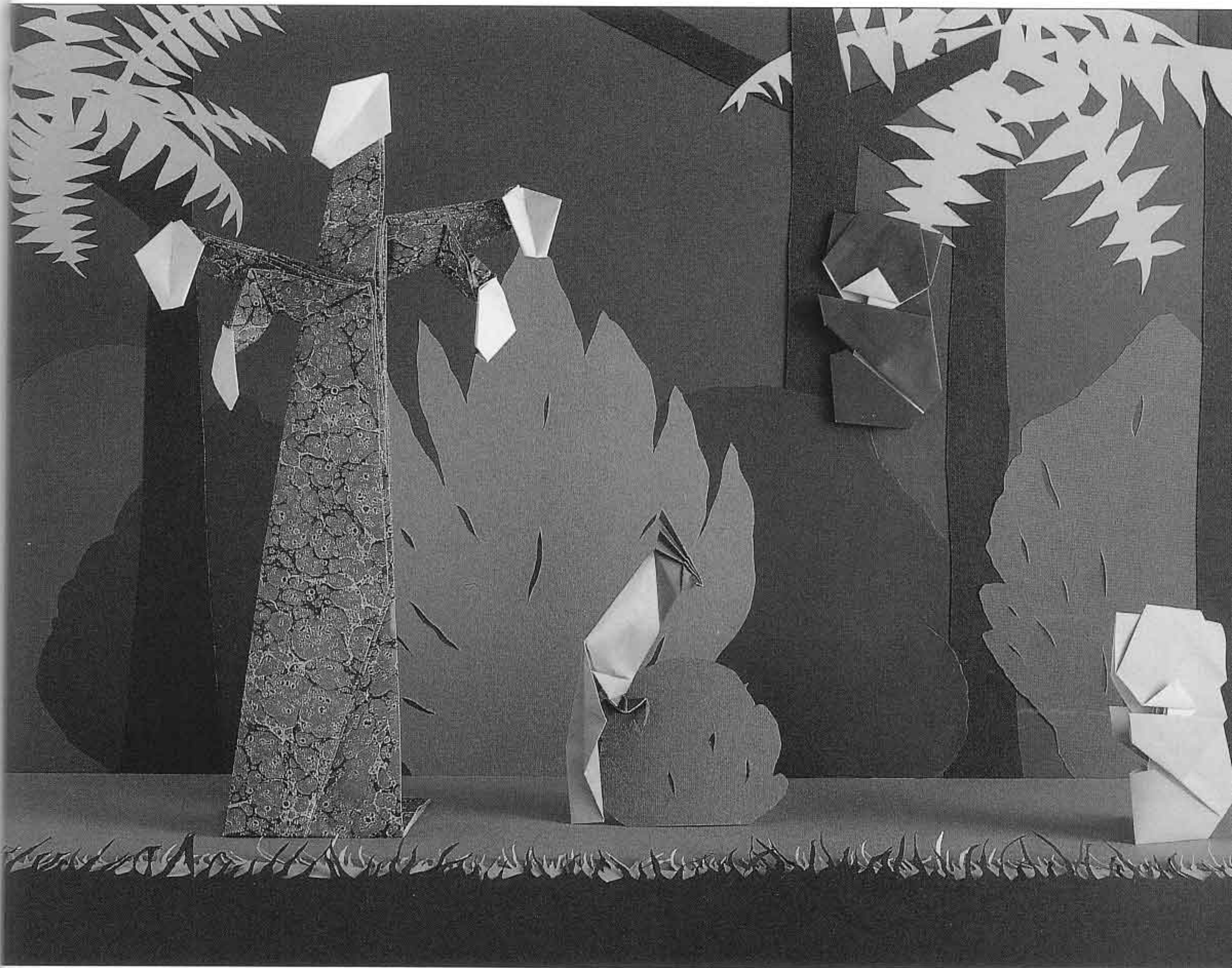

For this project, you will fold the following models:

Name	Page	Rating	Paper requirements
Koala	82	Low Intermediate	6 in (15 cm) square of brown and white paper.
Gum Tree	86	High Intermediate	20 in (50 cm) square of green and brown paper
Cockatoo	90	High Intermediate	6 in (15 cm) square of white and yellow paper

◆ koala ◆

designed by Edwin Corrie

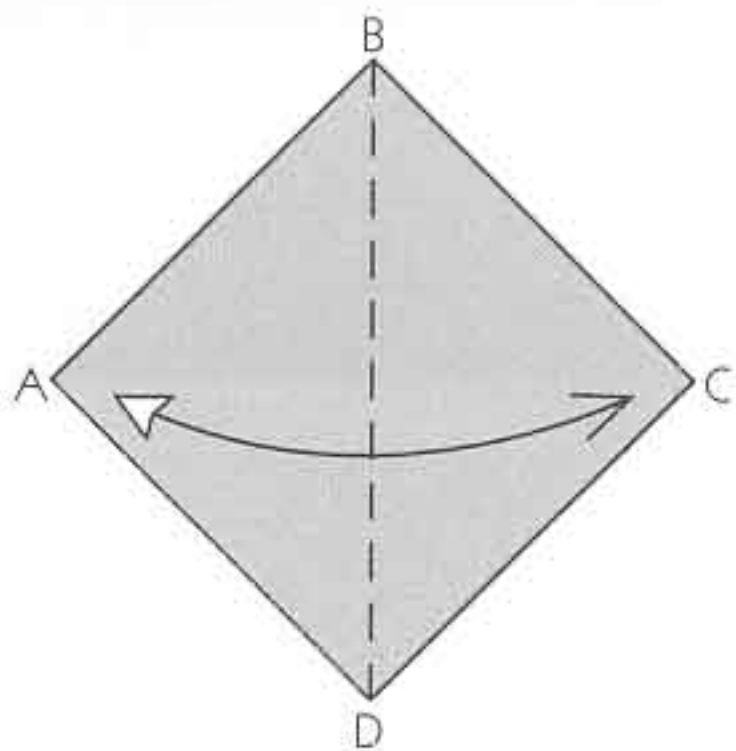
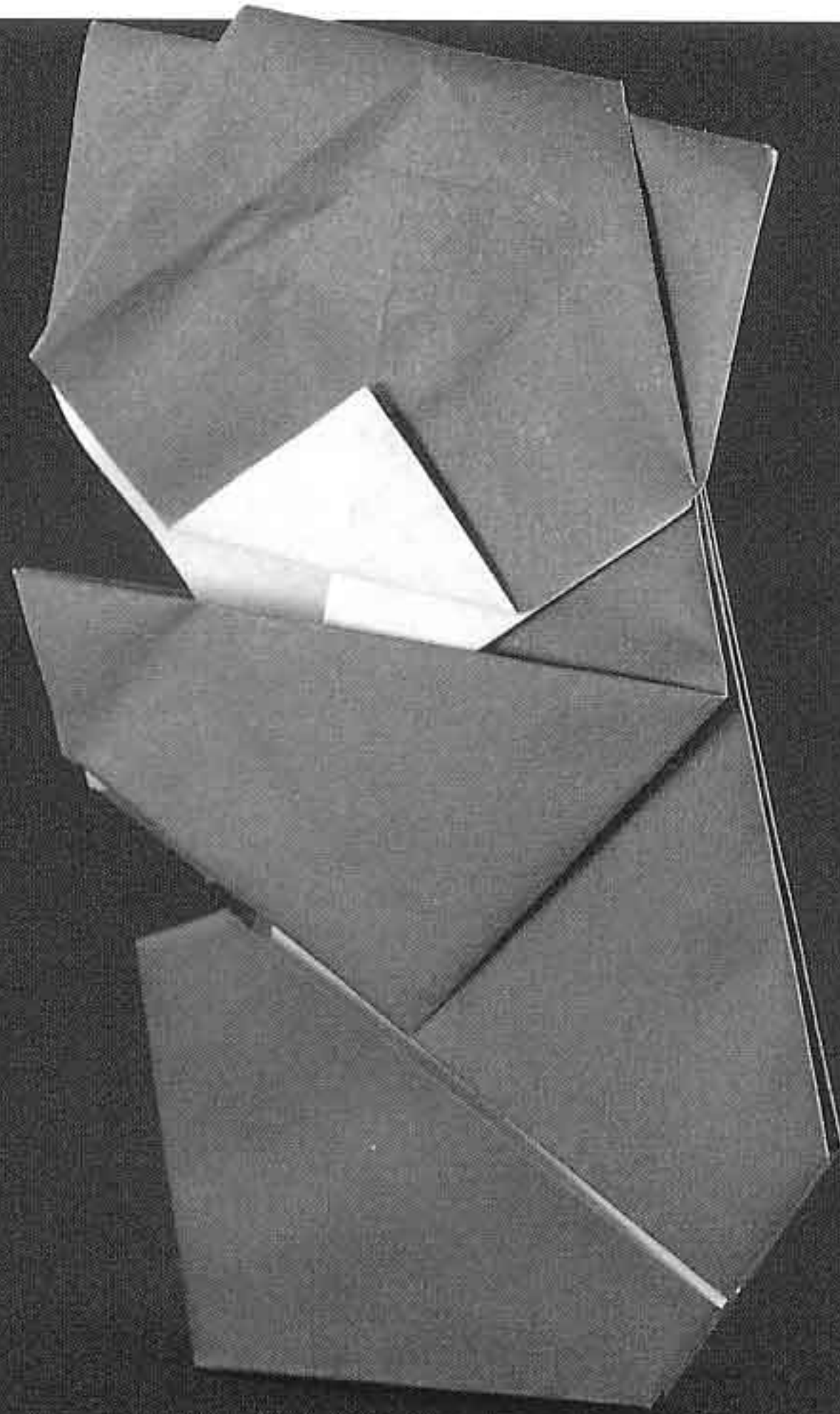

1 Begin with the colored side up. Fold the paper in half along one diagonal and unfold.

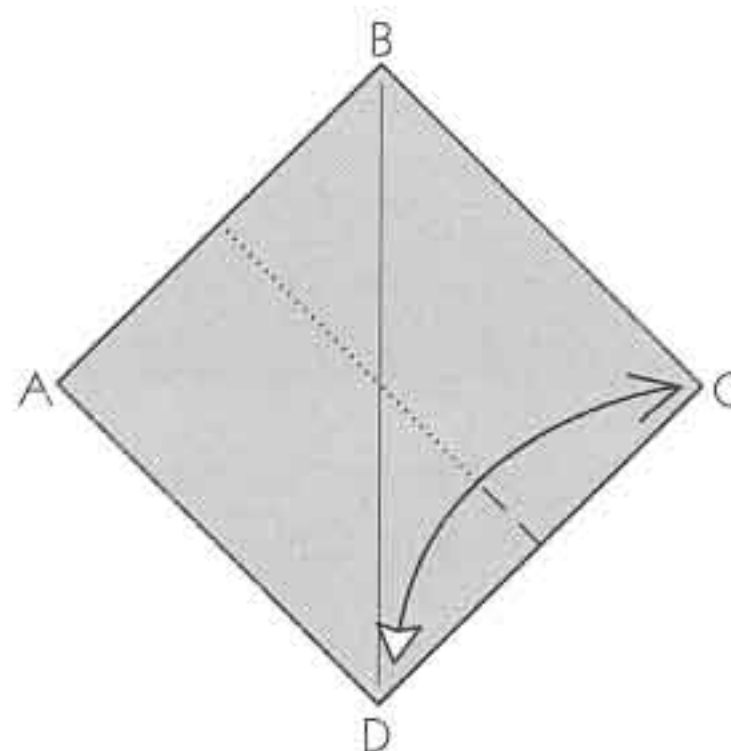

2 Fold edge AD up to edge BC; pinch at the right (along edge DC) and unfold.

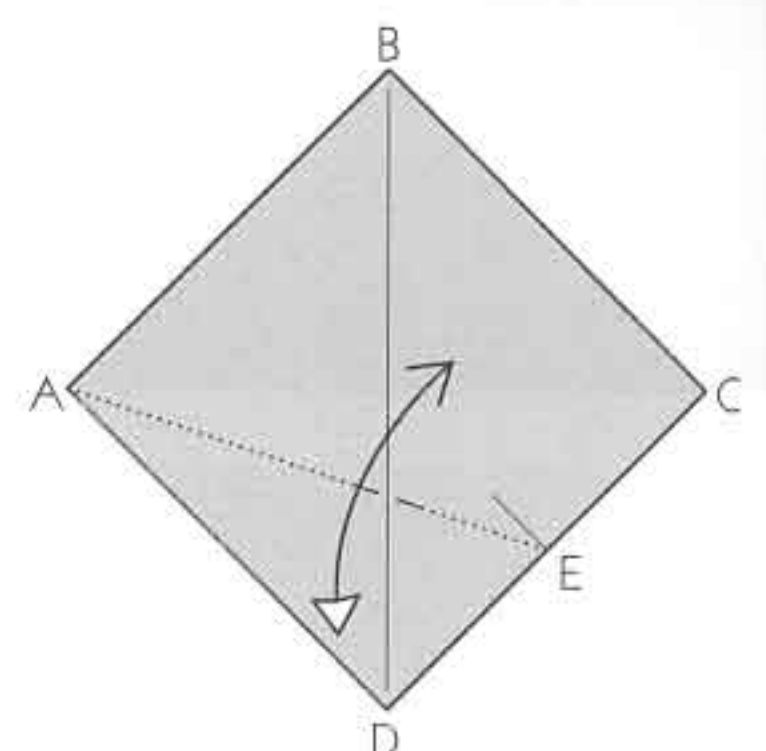

3 Fold edge AD up to form a crease running from point A to point E, making the crease sharp only where it crosses the diagonal BD. Unfold.

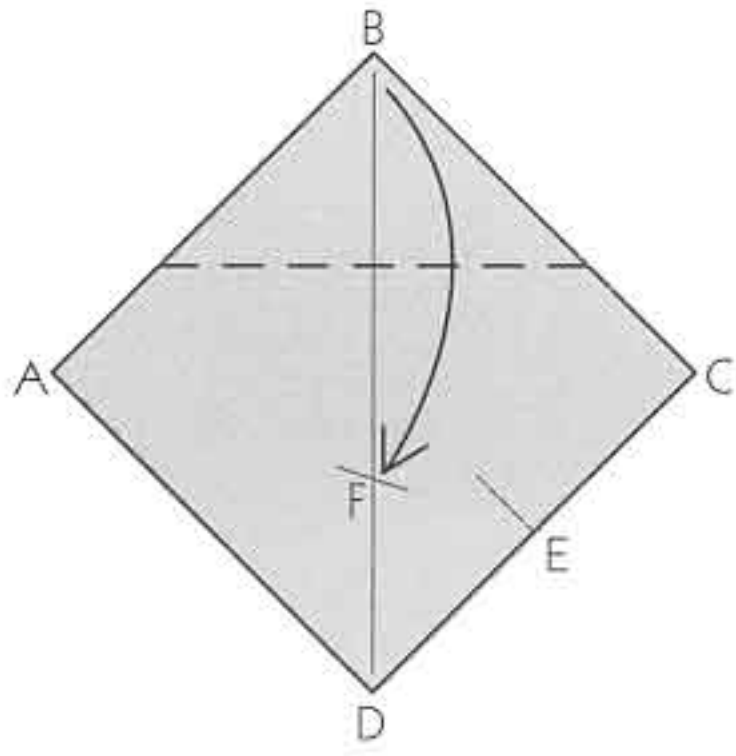

4 Fold down point B to the intersection of the two creases (point F).

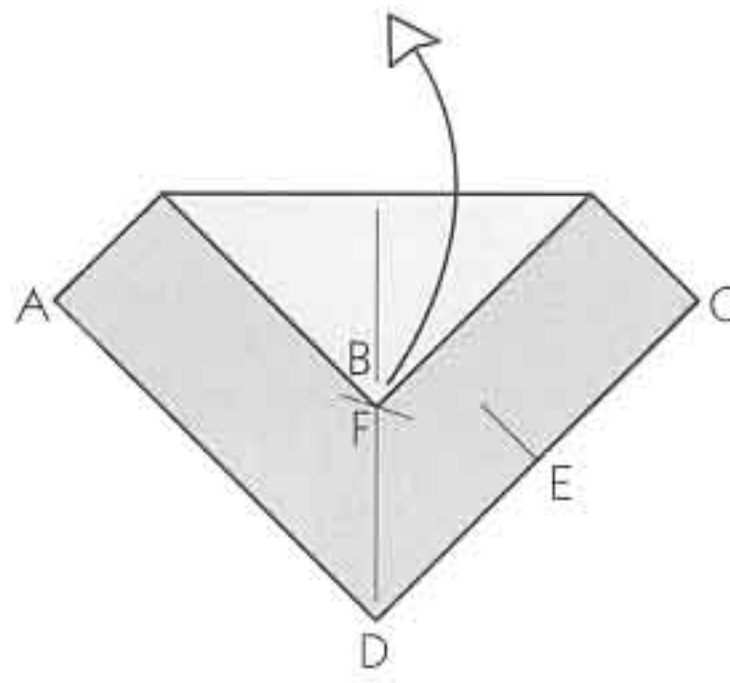

5 Unfold point B and turn the paper over.

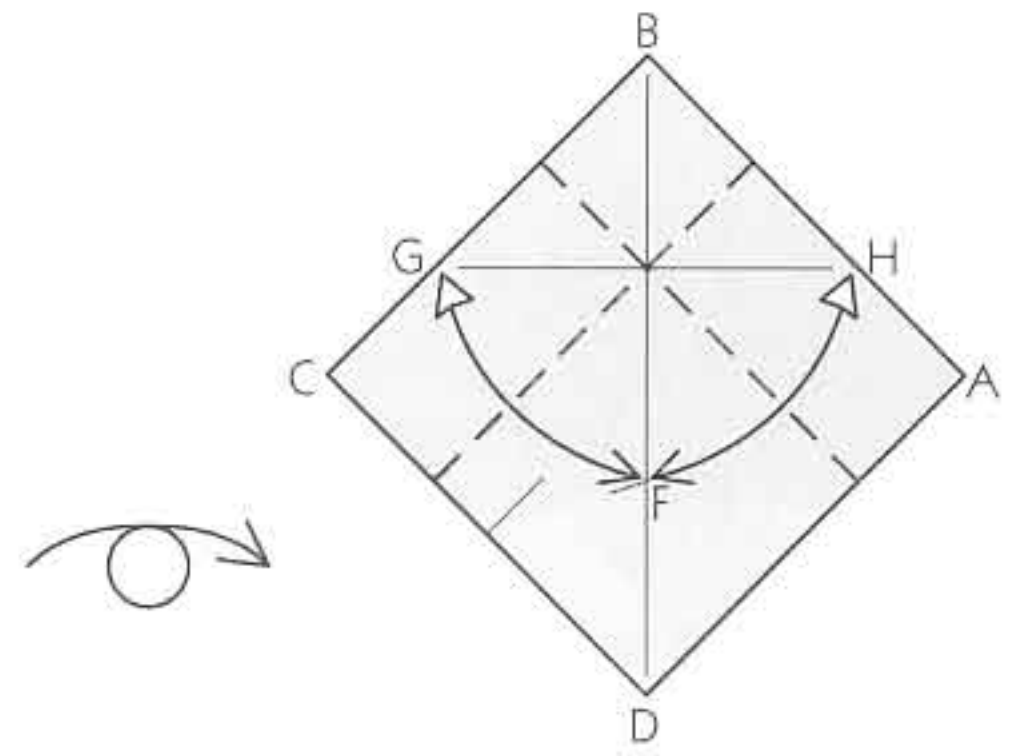

6 Fold edge BC so that point G lands on point F and unfold. Repeat on the right with edge BA and point H.

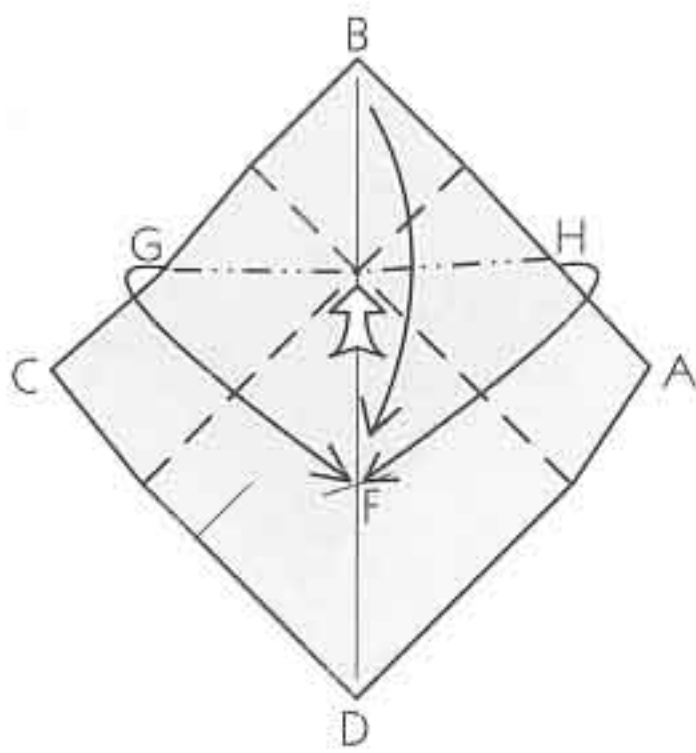

7 Push down in the middle while you bring points G, B, and H together at point F.

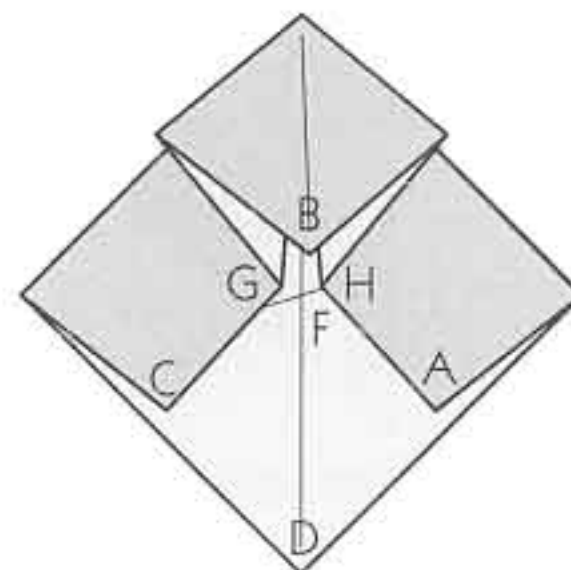

8 Flatten the model.

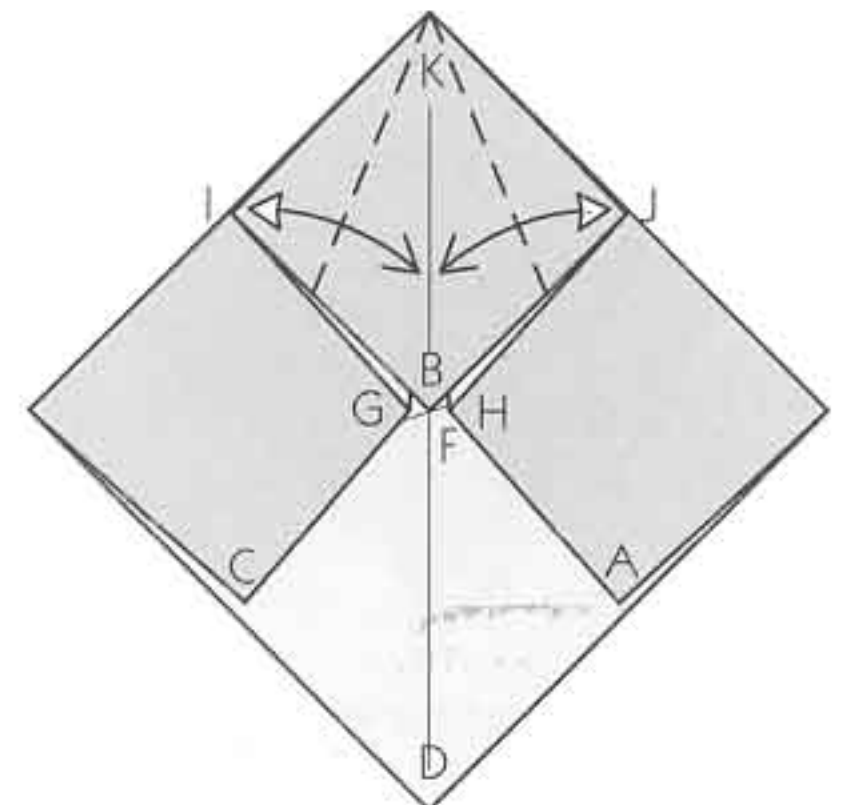

9 Fold in edges IK and JK (the two flaps at the top) to lie along the center line BK. Unfold.

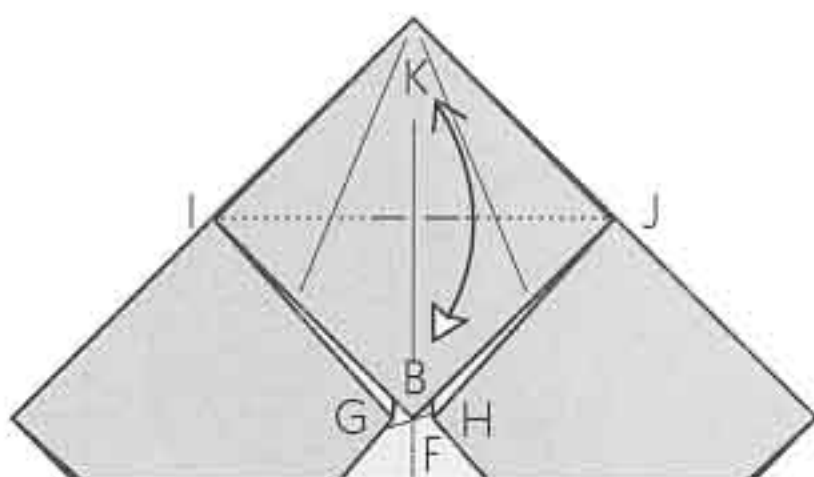

10 Fold corner B up to point K; pinch in the middle and unfold.

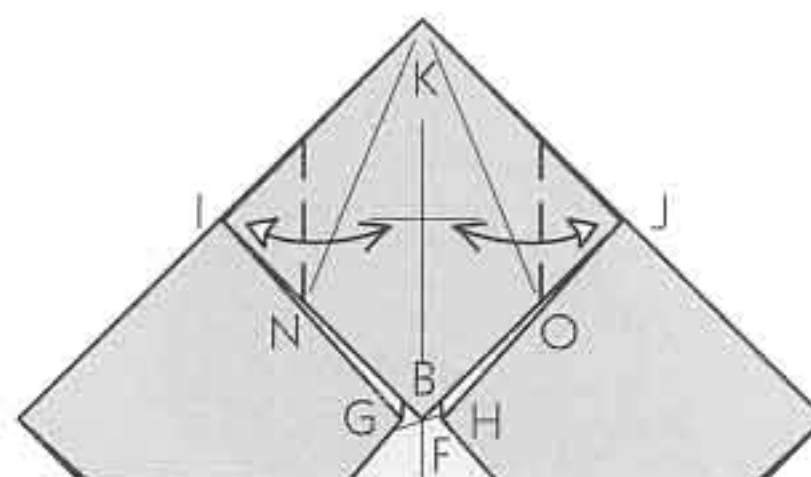

11 Fold in corners I and J so that the new creases hit points N and O and points I and J lie on the horizontal crease you just made (they will not meet in the middle). Unfold.

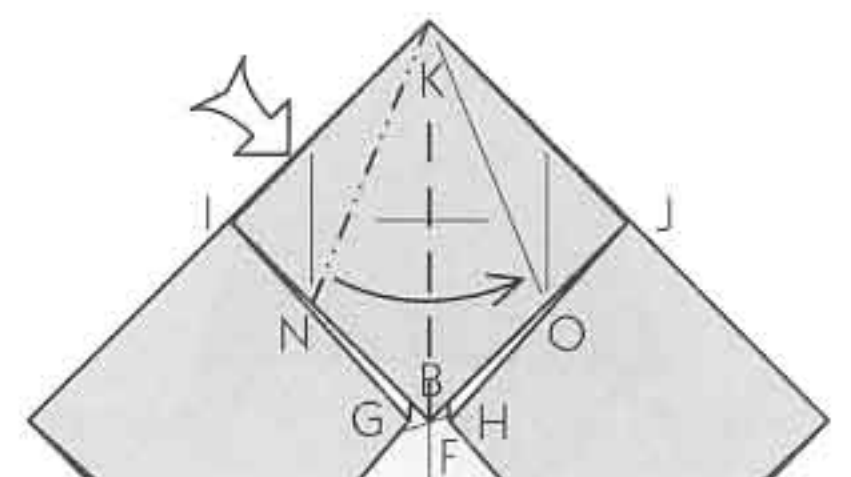

12 Squash-fold edge IK.

Australian forest

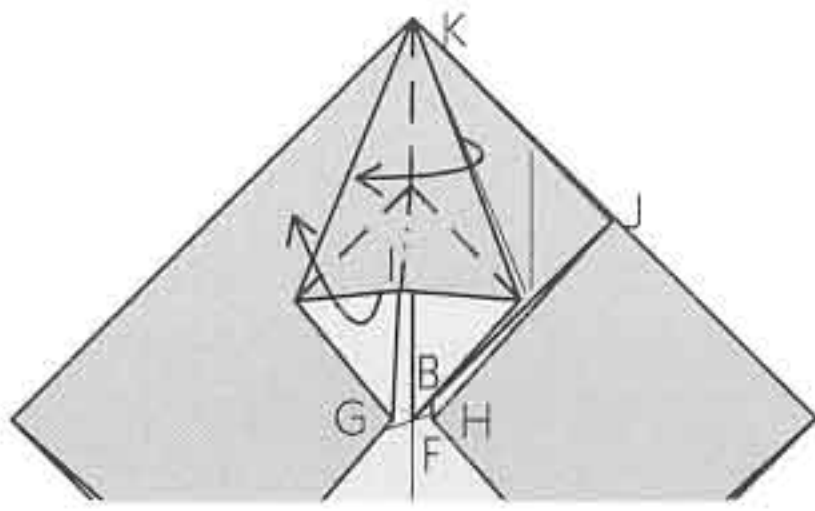

13 Close up the squash fold while you lift up point I. The valley folds lie on existing creases.

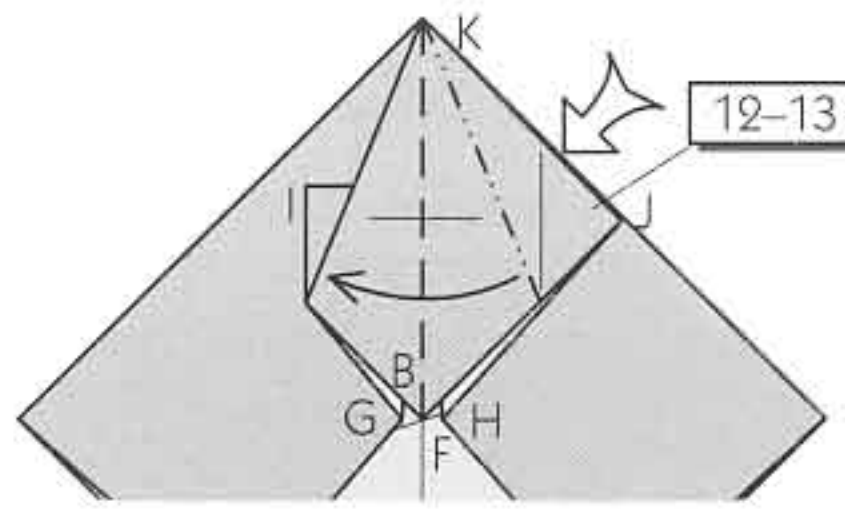

14 Repeat steps 12–13 on the right.

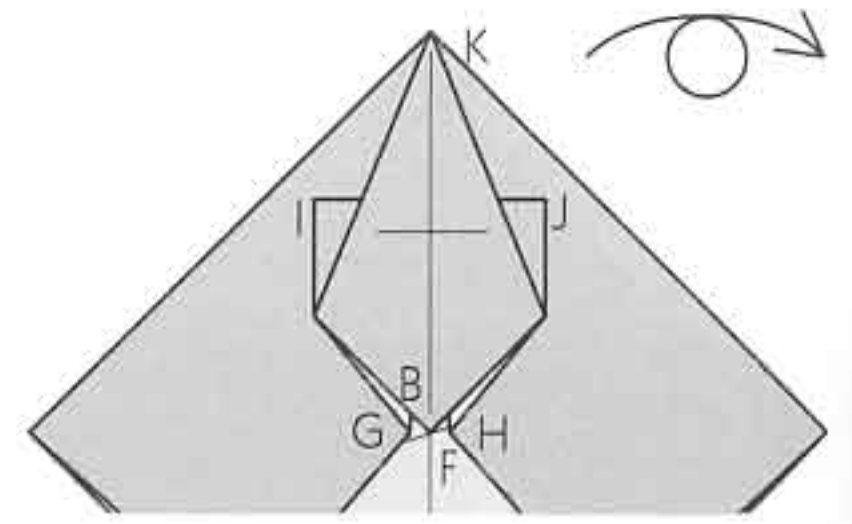

15 Turn over the model.

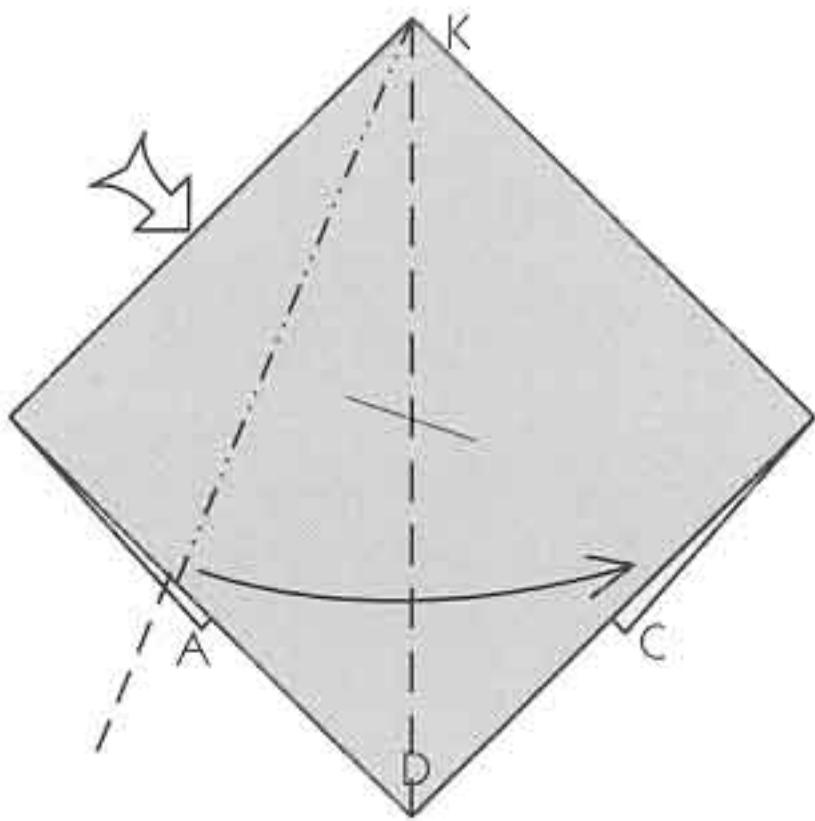

16 Squash-fold the left edge.

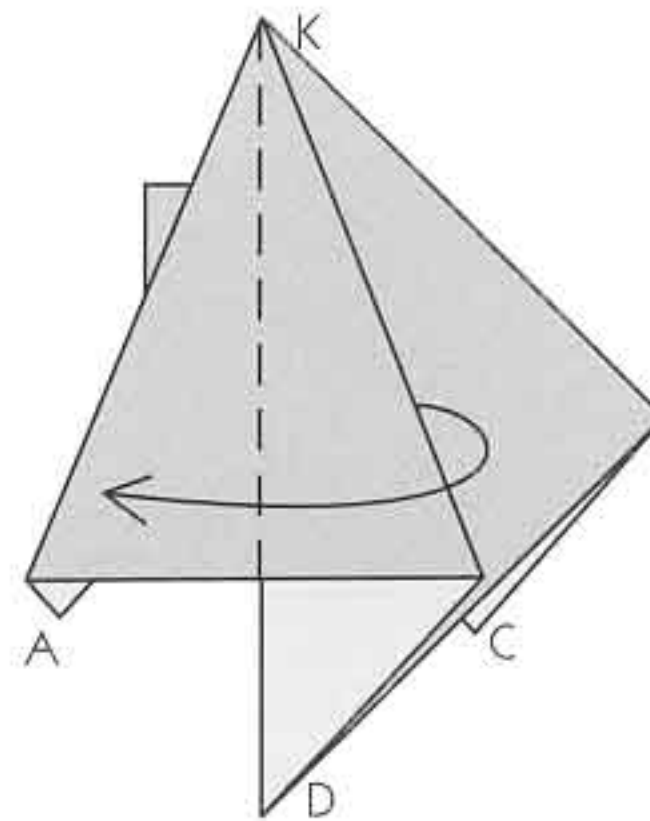

17 Fold the squashed edge to the left.

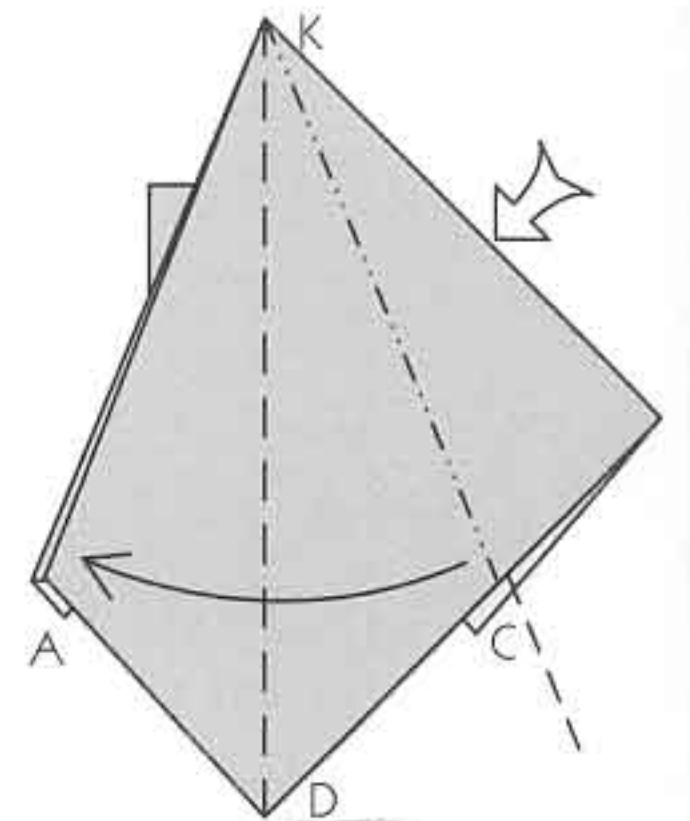

18 Squash-fold the right edge.

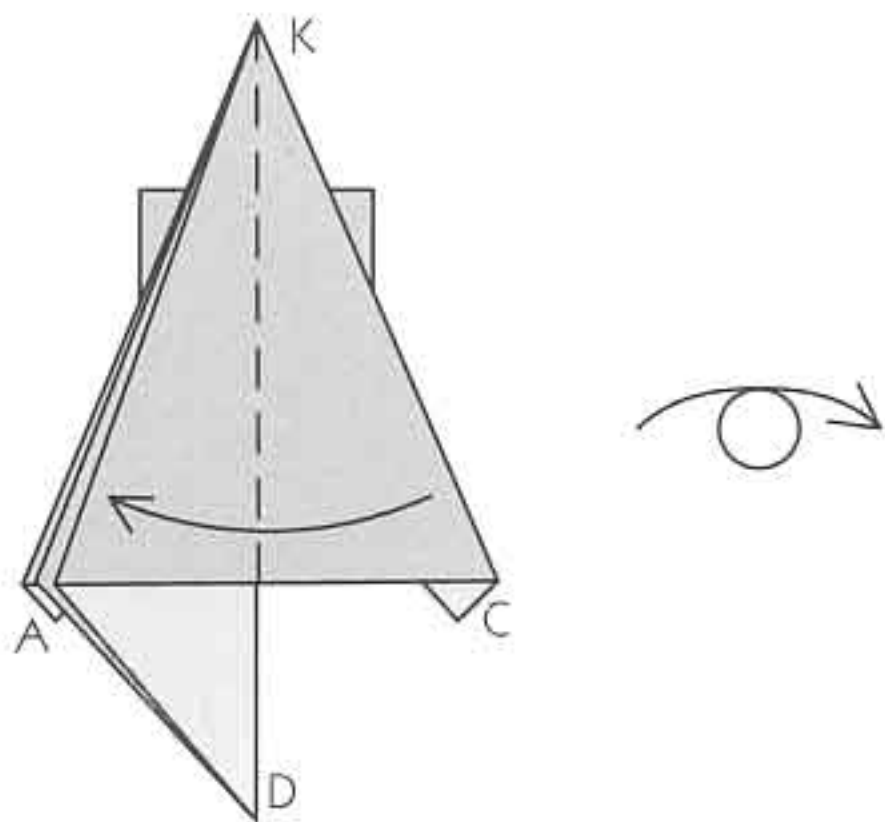

19 Fold corner C to the left and turn over the model.

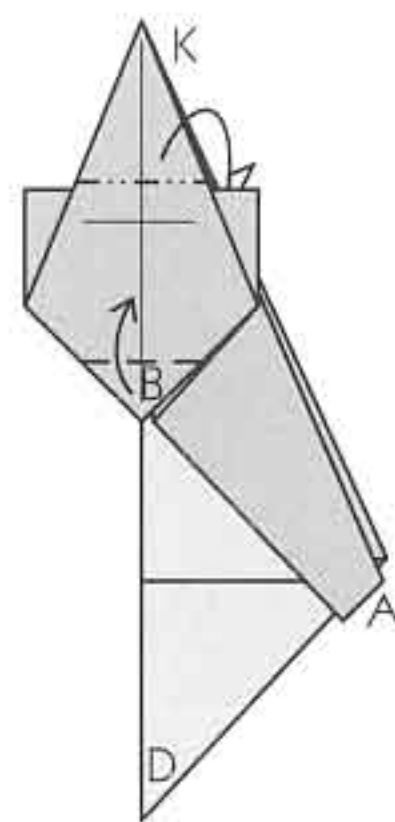

20 Mountain-fold corner K behind. Fold up corner B.

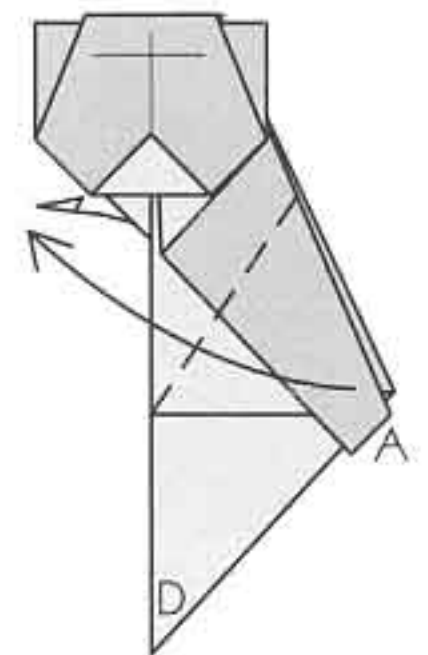

21 Fold flap A over to the left so that its upper edge is horizontal and parallel to the bottom of the nose. Fold the corresponding flap behind to match.

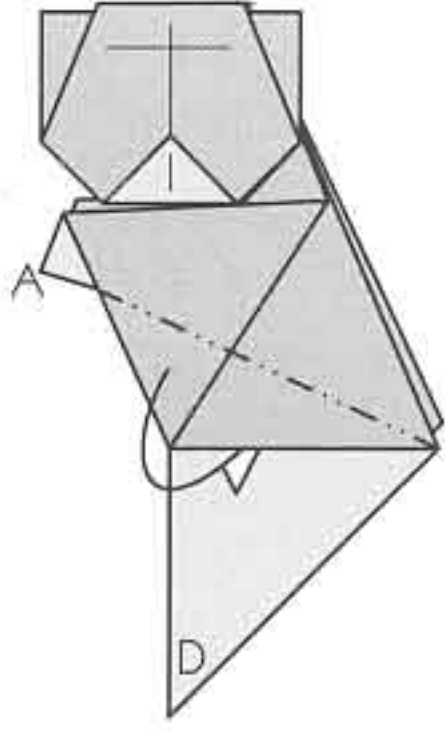

22 Mountain-fold the corner underneath.

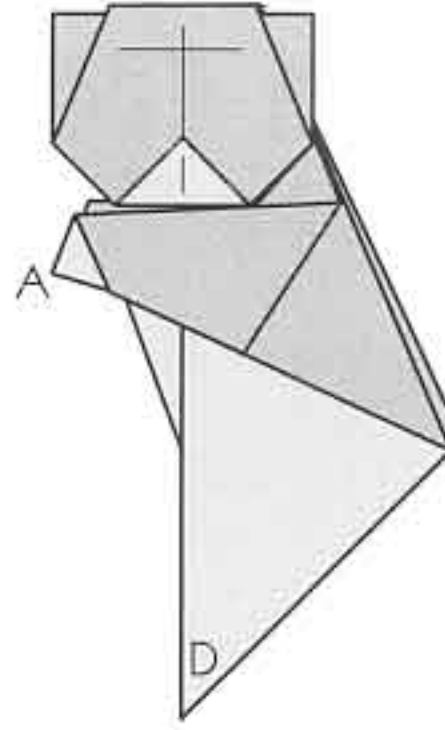

23 Turn over the model.

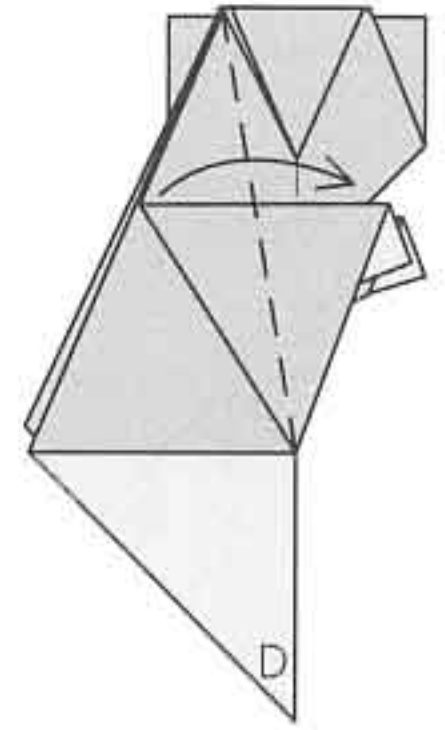
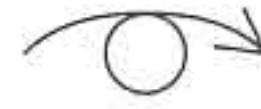

24 Fold one layer to the right. Be careful that the two flaps at the right (the forelegs) remain matched.

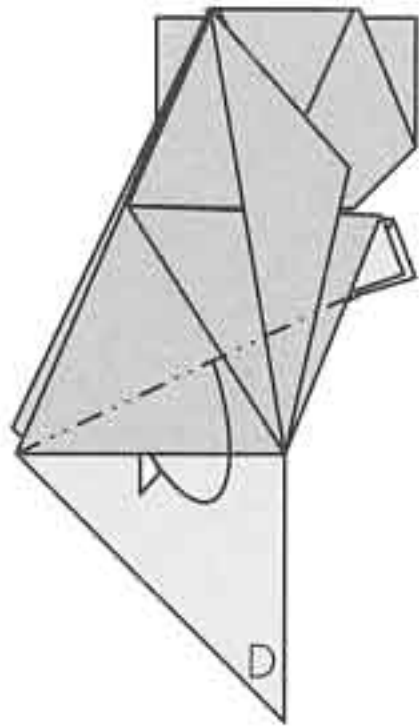

25 Mountain-fold the corner underneath.

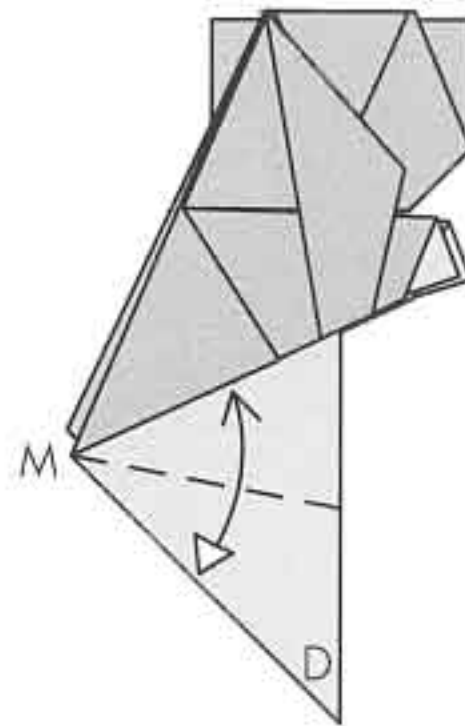

26 Fold edge MD up to the folded edge, crease, and unfold. Turn over the model.

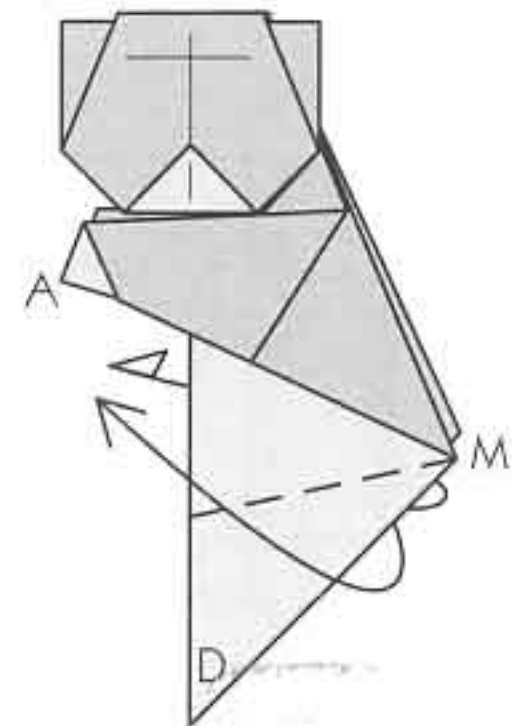
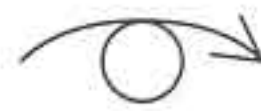

27 Outside reverse-fold point D.

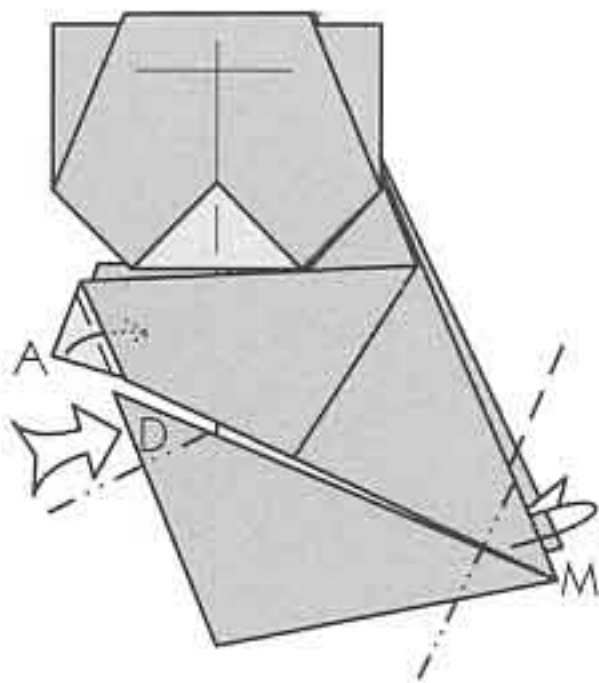

28 Reverse-fold point D. Mountain-fold point M inside; repeat behind. Fold corner A into the pocket; repeat behind.

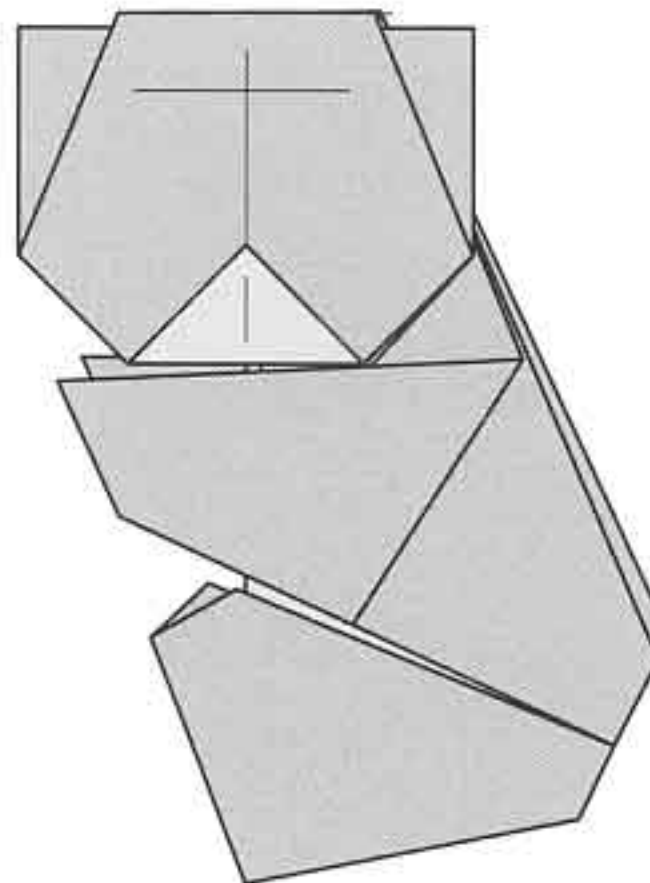

Finished Koala.

◆ gum tree ◆

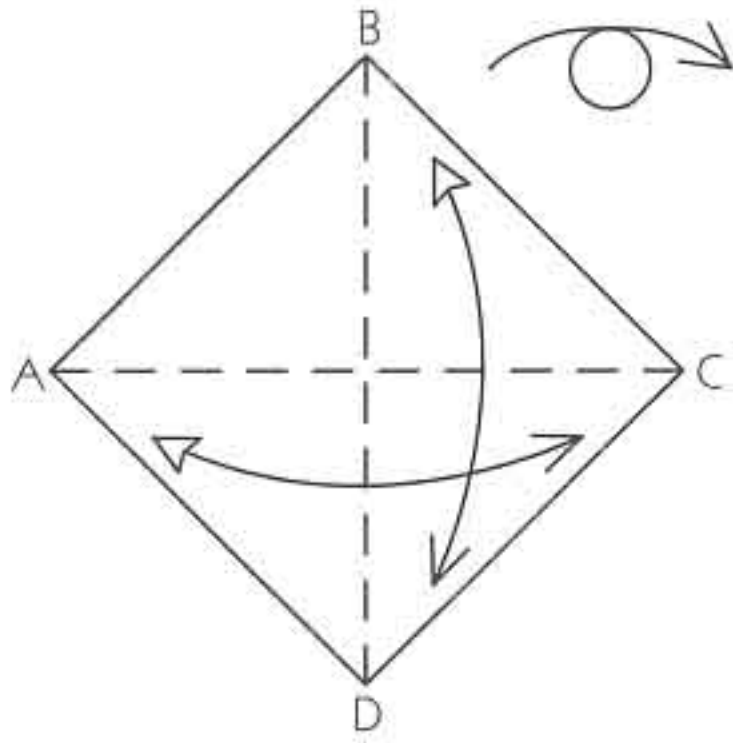

1 Begin with the colored side up. Fold and unfold along the diagonals. Turn over the paper.

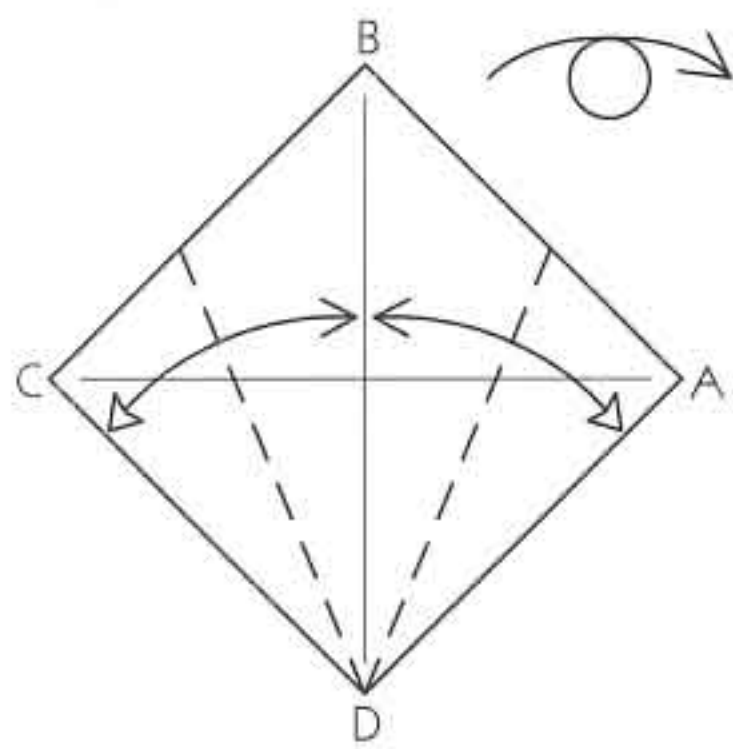

2 Fold in edges CD and AD to meet along the center line; unfold and turn the paper back over.

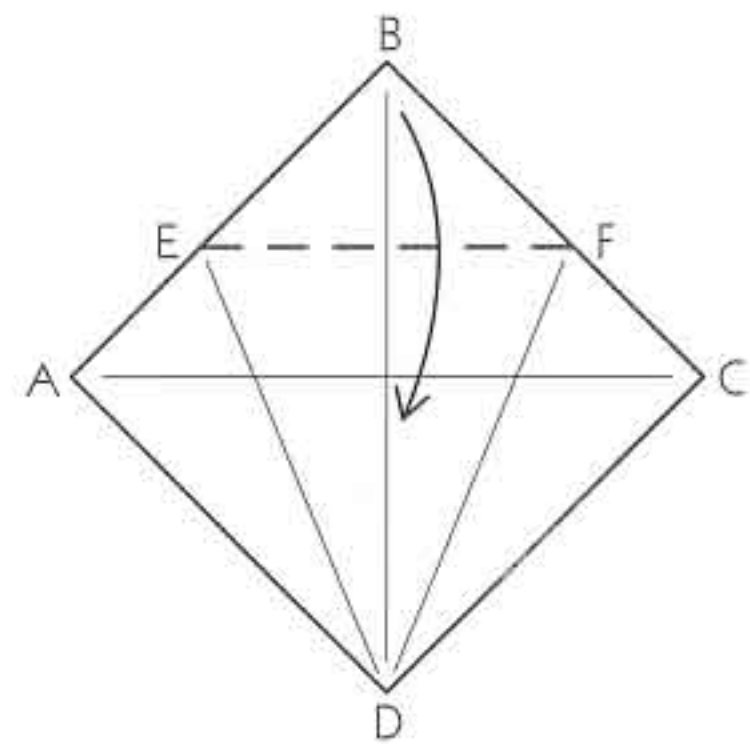

3 Fold corner B down along a crease that runs from point E to point F.

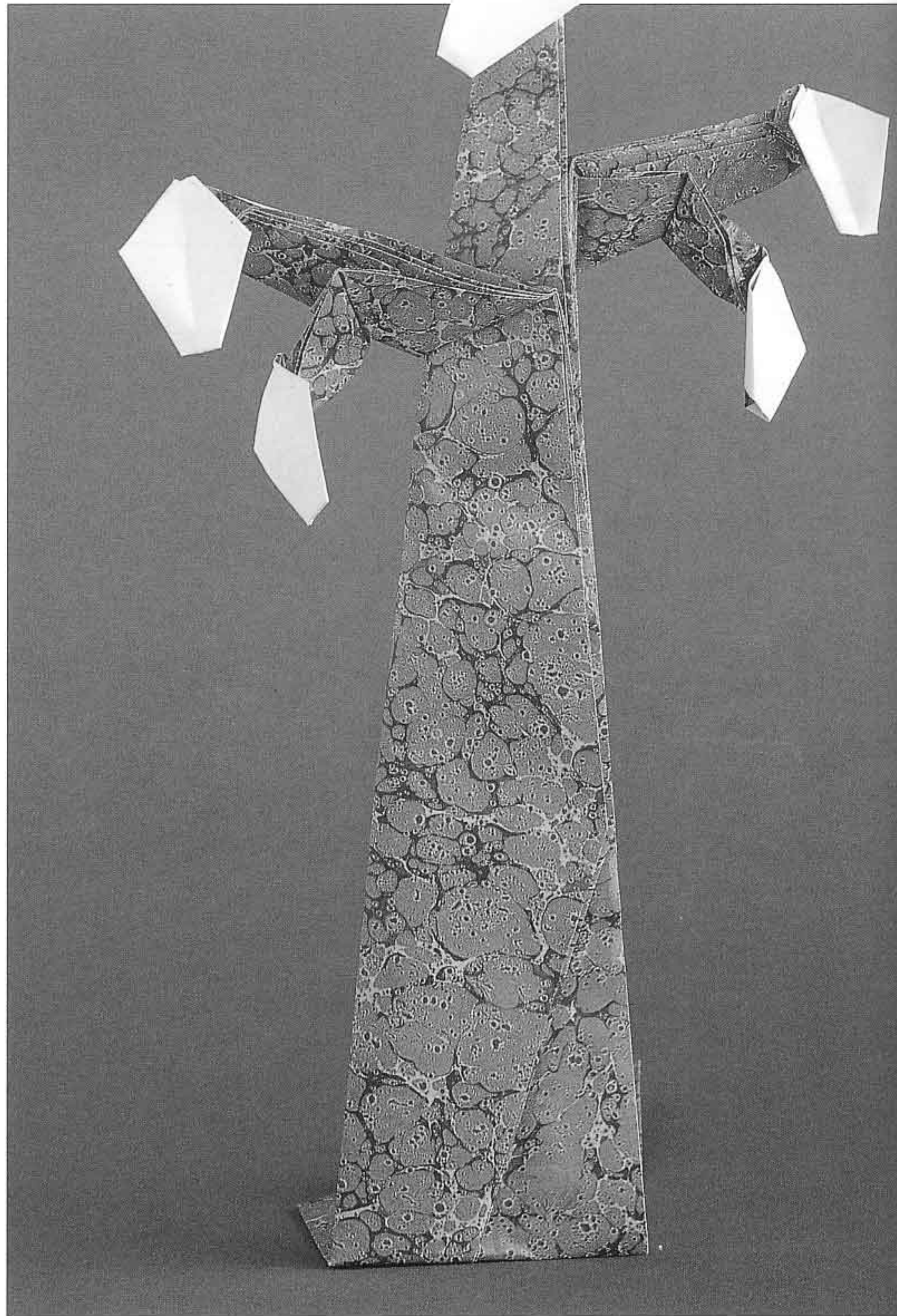

gum tree

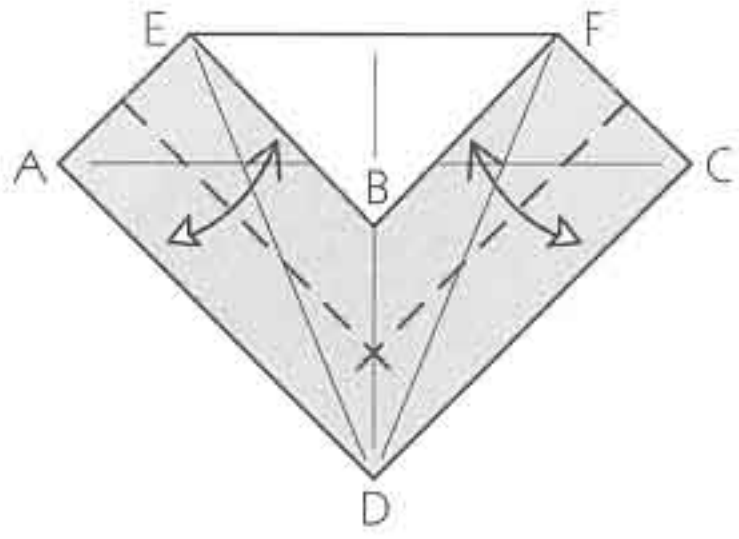

4 Fold edge AD to edge EB and unfold. Fold edge DC to edge BF and unfold.

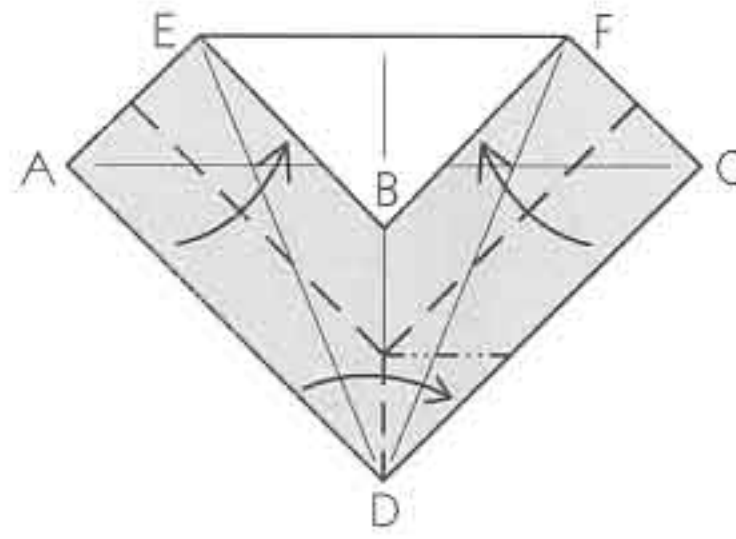

5 Use the creases you just made to fold a rabbit ear from point D.

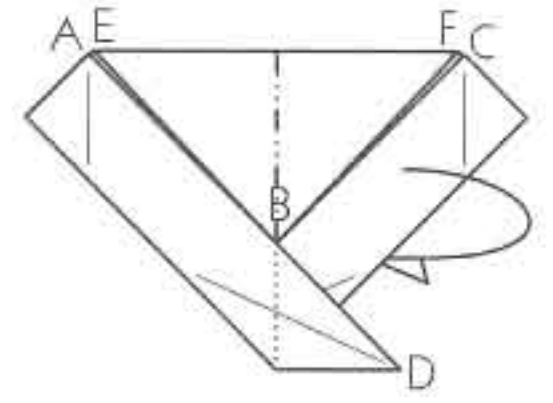

6 Mountain-fold the right half of the model behind.

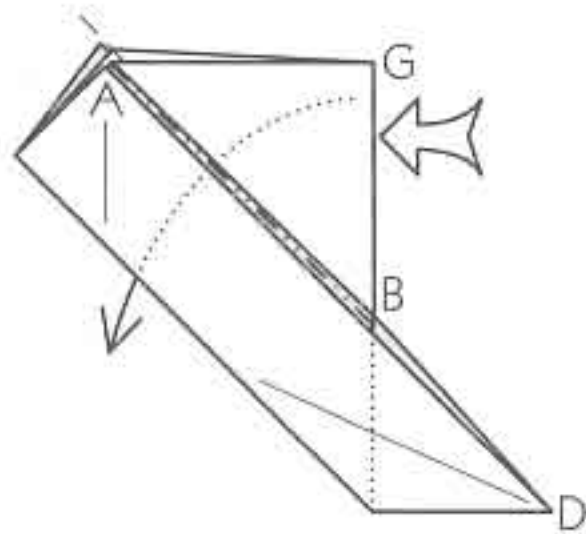

7 Reverse-fold corner G. Rotate the model 1/8 turn clockwise.

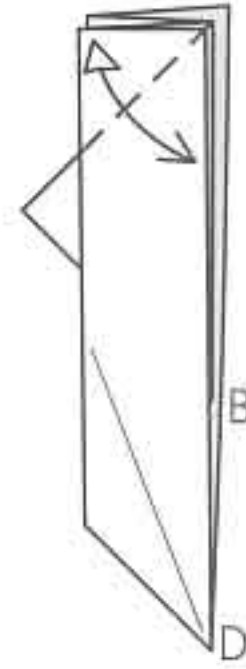

8 Fold and unfold. Repeat behind.

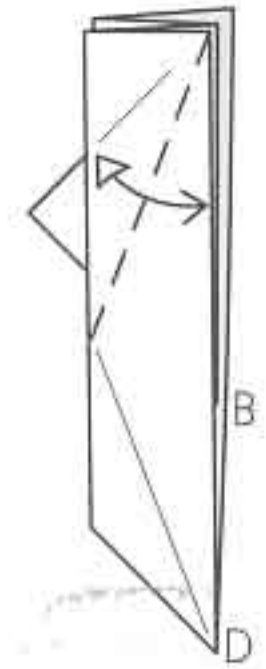

9 Fold and unfold. Repeat behind.

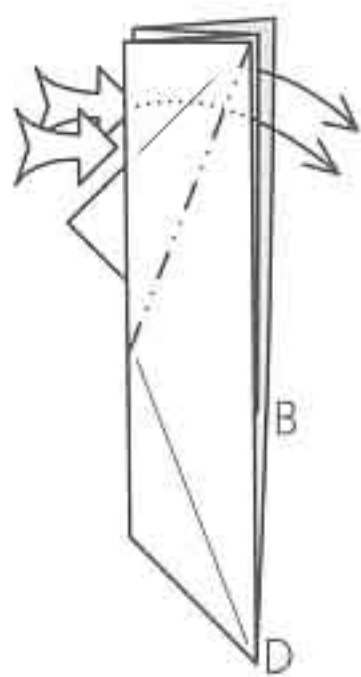

10 Reverse-fold two edges on the creases you made in step 9.

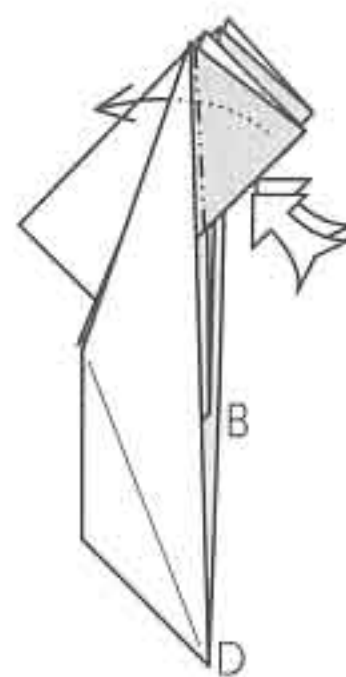

11 Reverse-fold the two edges back to the left.

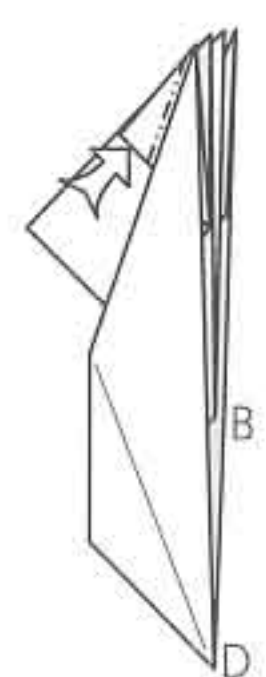

12 Reverse-fold the edge. Repeat behind.

Australian forest

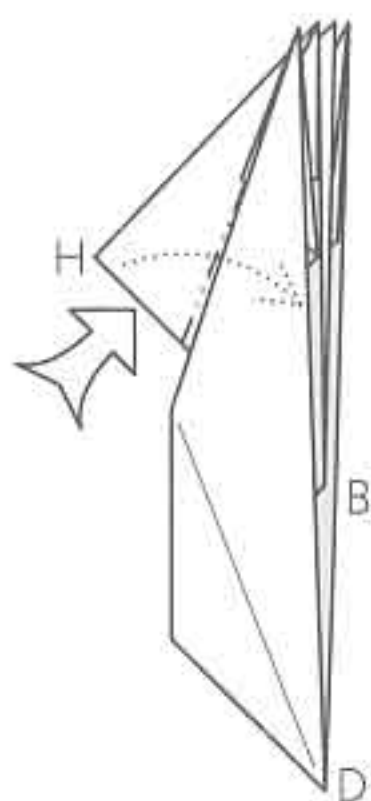

13 Reverse-fold corner H.

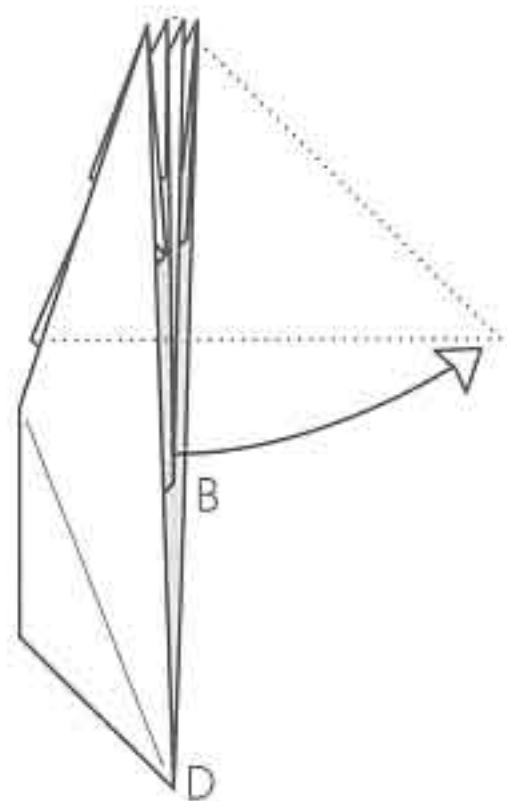

14 Pull corner B (one of the original corners of the square) as far out as possible.

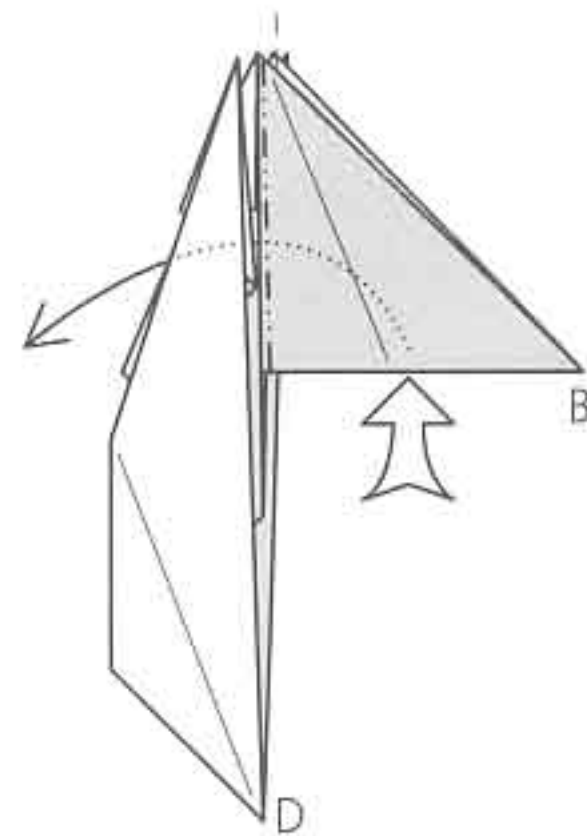

15 Reverse-fold corner B to the left along the center line.

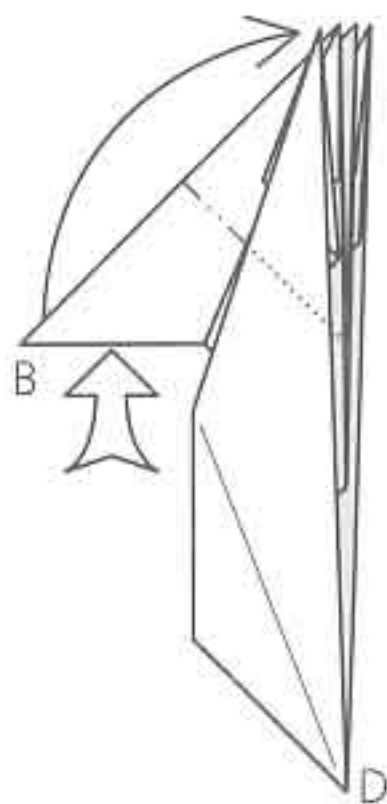

16 Reverse-fold corner B upward to line up with the other points.



17 Reverse-fold both edges.

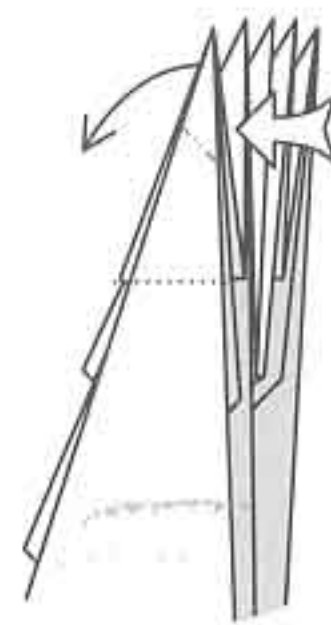

18 This is a close-up of the top of the model; there should be five points at the top. Reverse-fold a little less than half of the near point to the left.

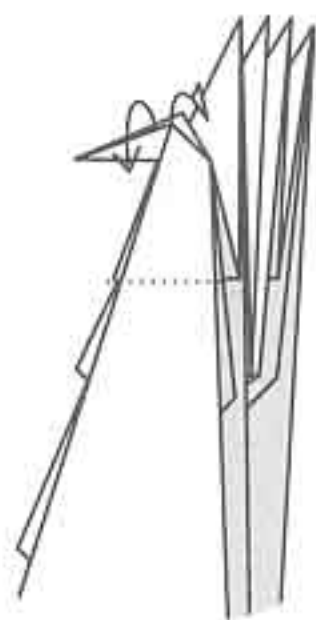

19 Wrap all layers from the inside to the outside. This is much easier if you open out the point, wrap the layers, and then re-fold.

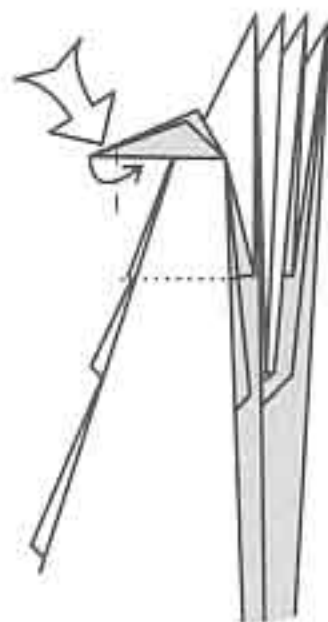

20 Fold the tip of the colored point inside and underneath.

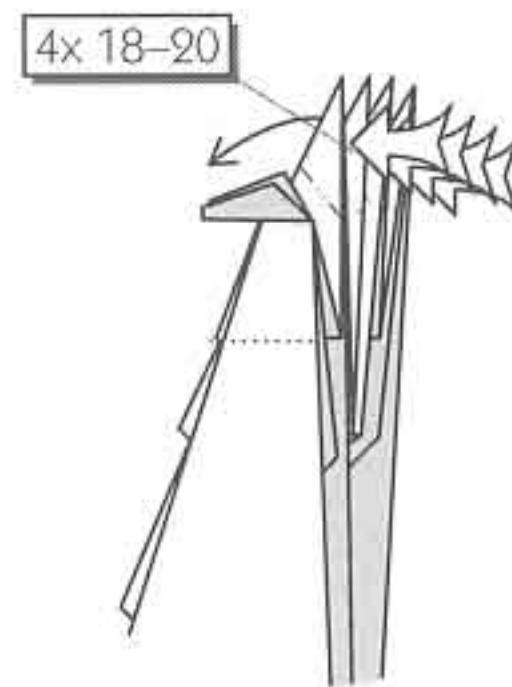

21 Repeat steps 18-20 on the other four flaps.

gum tree

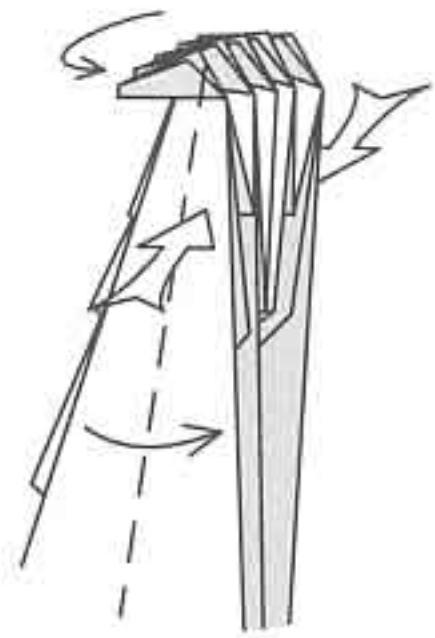

22 Press all the layers together and carefully valley-fold through them all. The colored points at the top swing to the right.

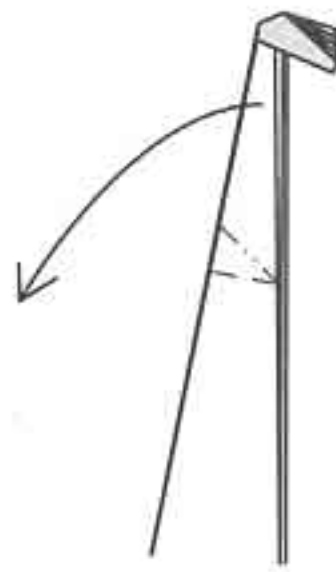

23 Crimp two points downward, folding them together as one. It will be easier if you partially unfold the previous step to accomplish this.

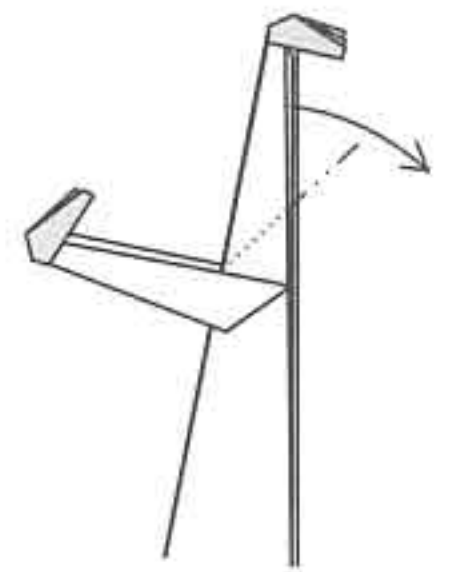

24 Reverse-fold out two more points, folding them together as one.

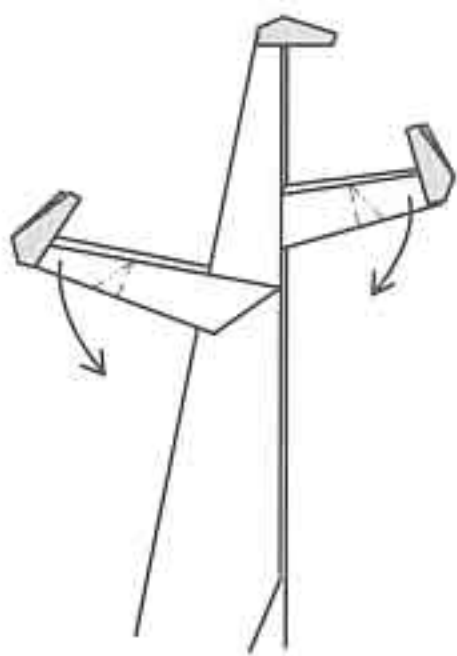

25 Crimp one of the two points downward on each side.

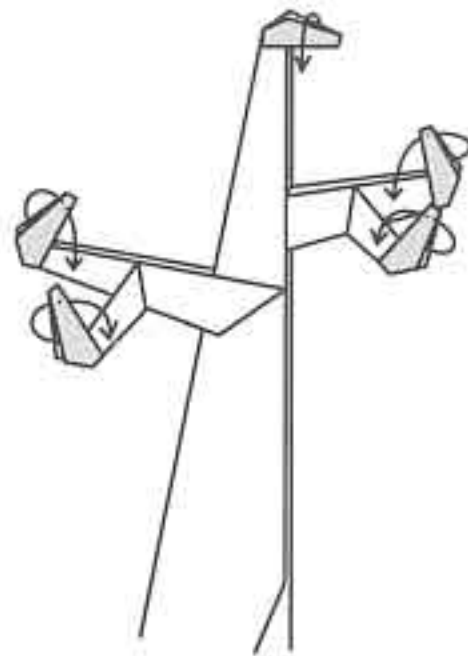

26 Open up each of the leaves and twist them around to a natural position.

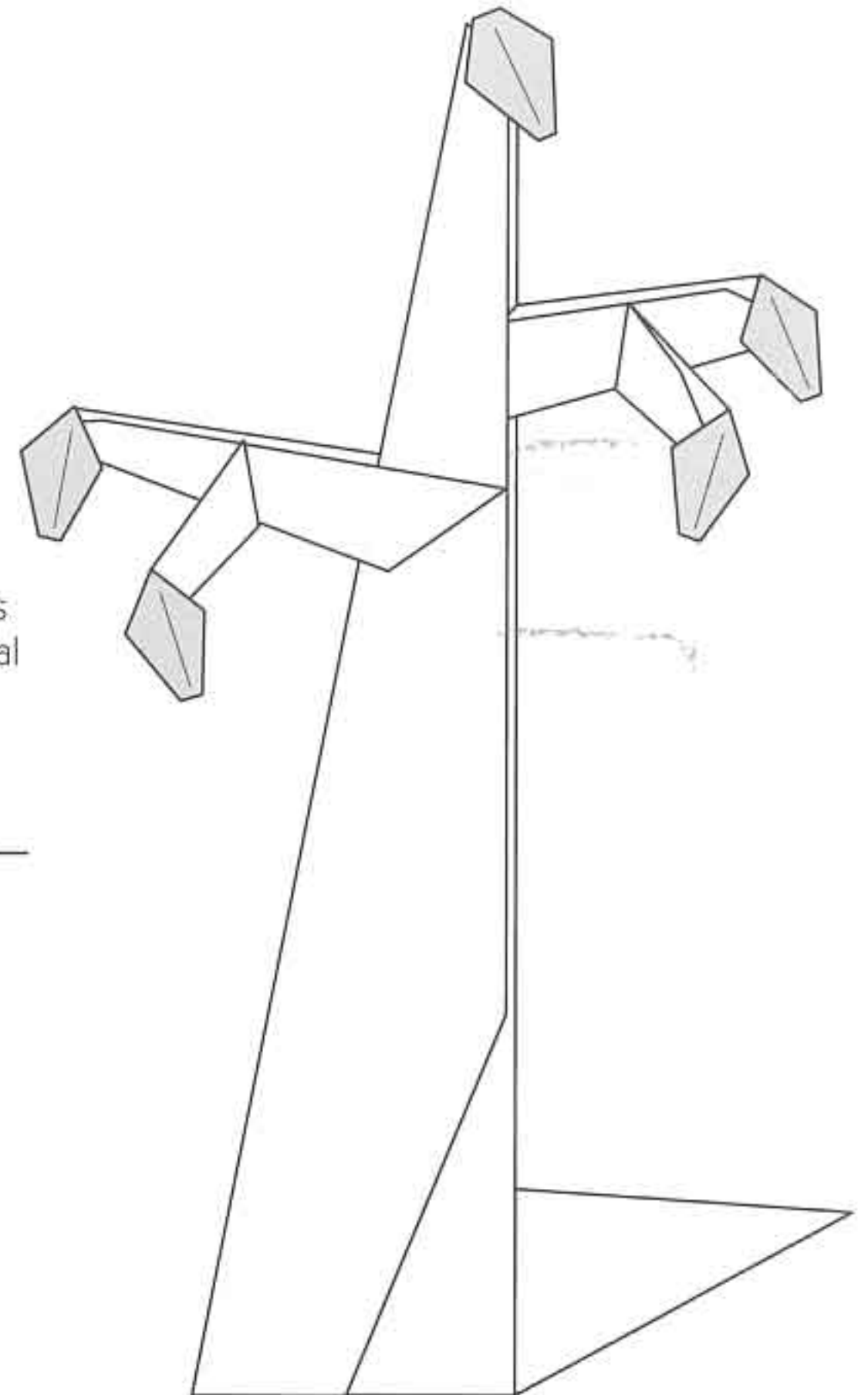

Finished Gum Tree.

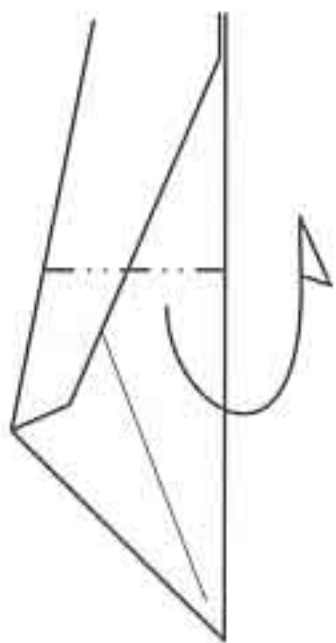

27 Mountain-fold a portion of the bottom behind to make a base.

◆ cockatoo ◆

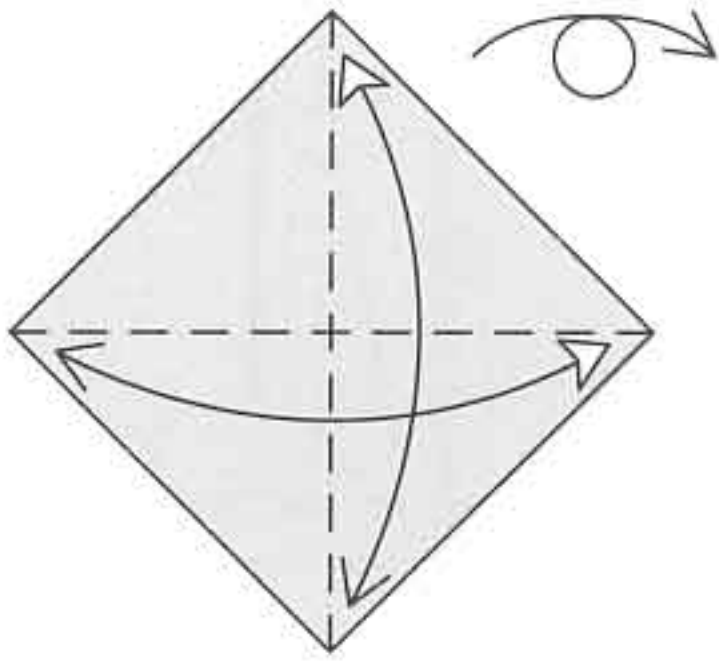

1 Begin with the colored side up. Fold and unfold along the diagonals. Turn the paper over.

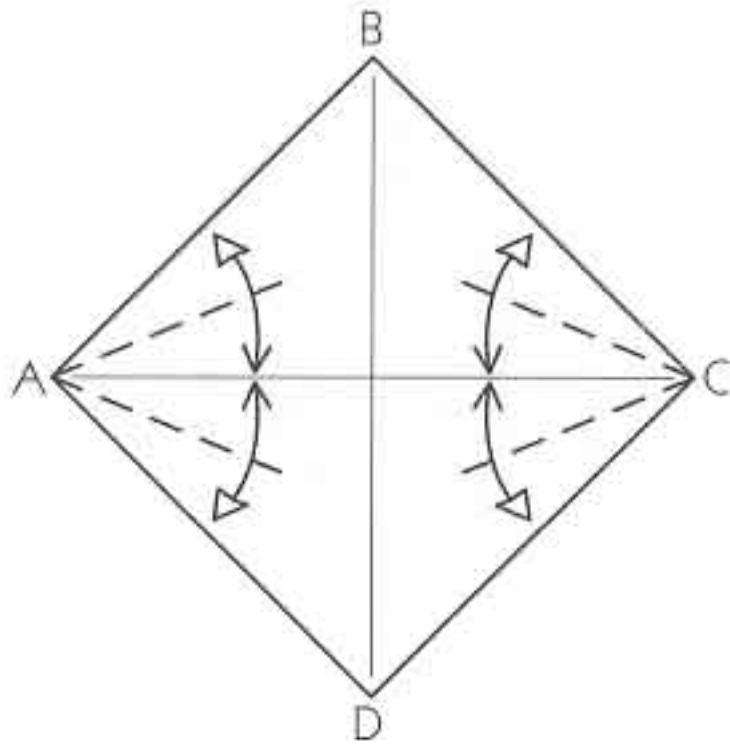

2 Fold edge AB to the horizontal crease AC, making the crease sharp only about halfway to the middle; unfold. Repeat on the other three edges.

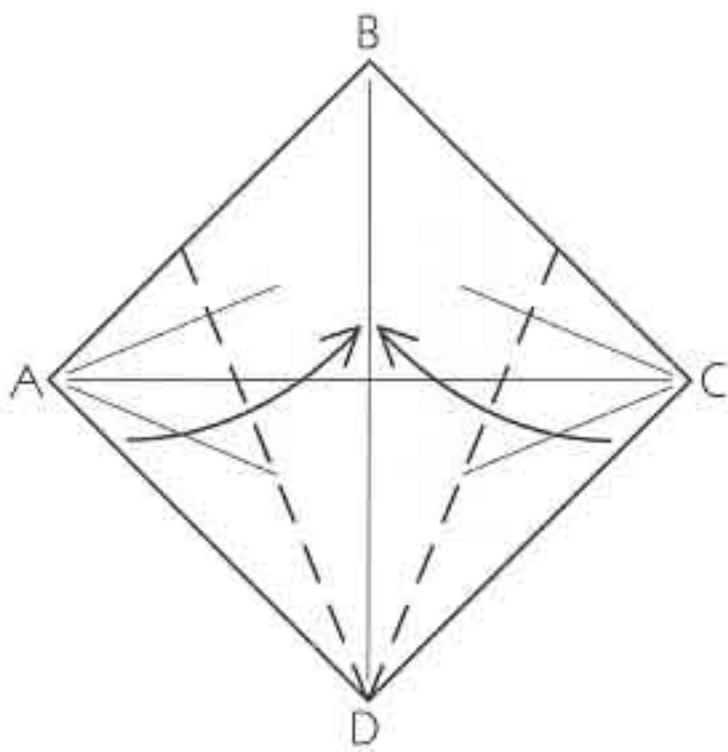

3 Fold in edges AD and CD to the center line.

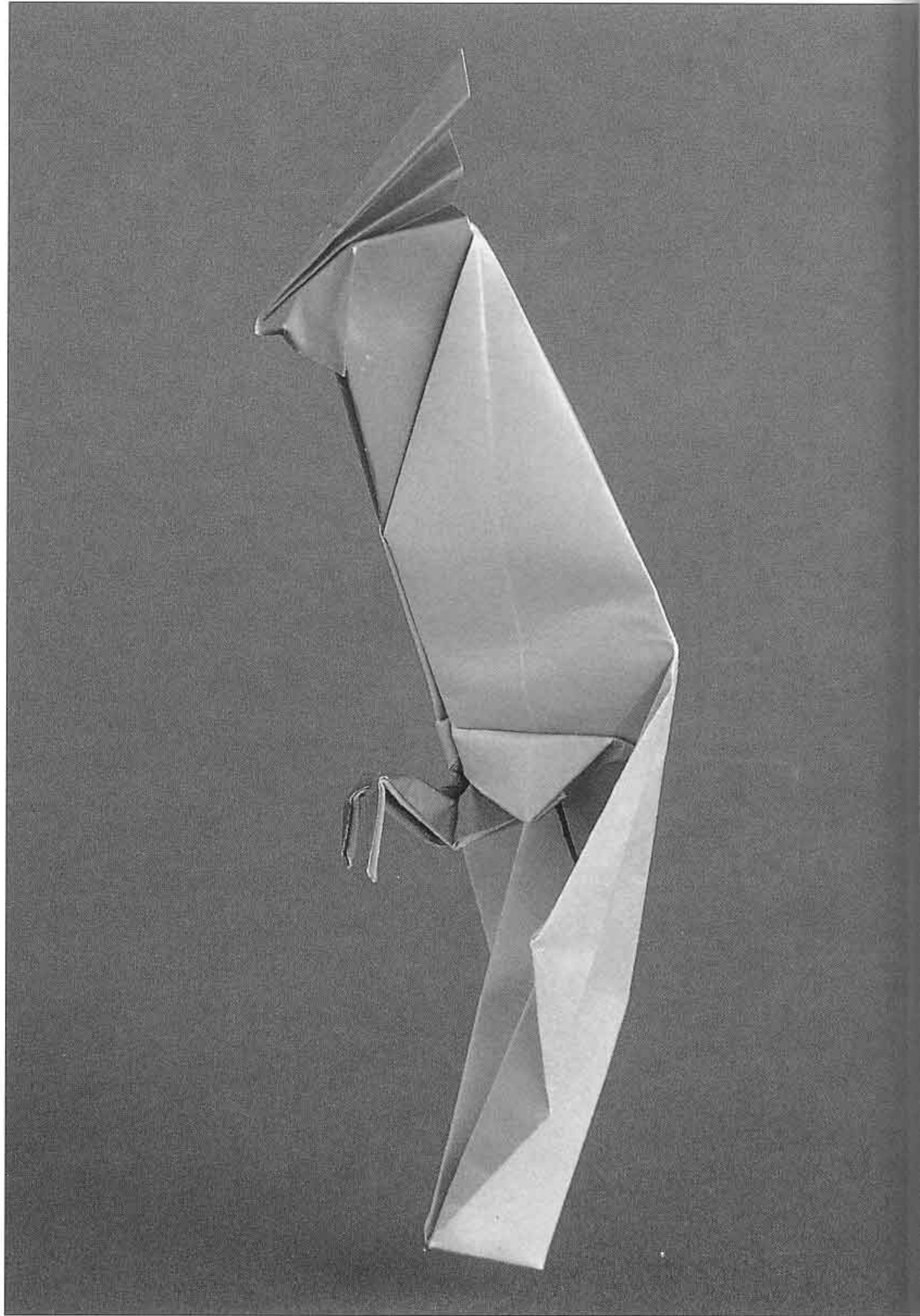

cockatoo

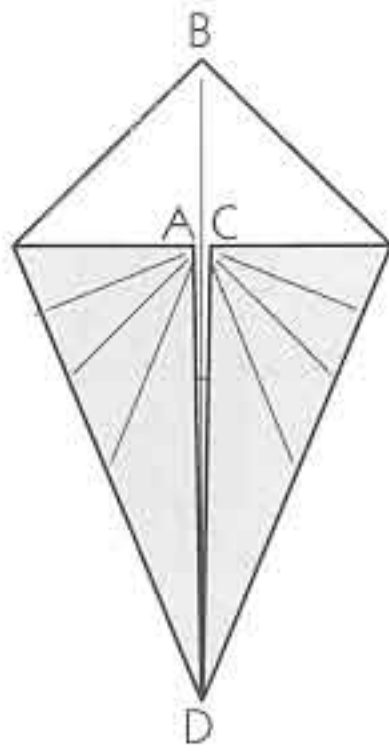

4 Turn over the model.

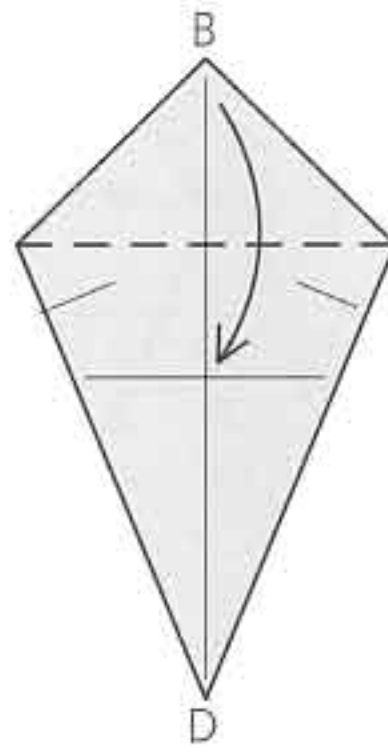
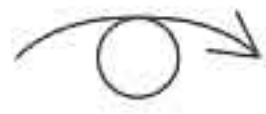

5 Fold down corner B.

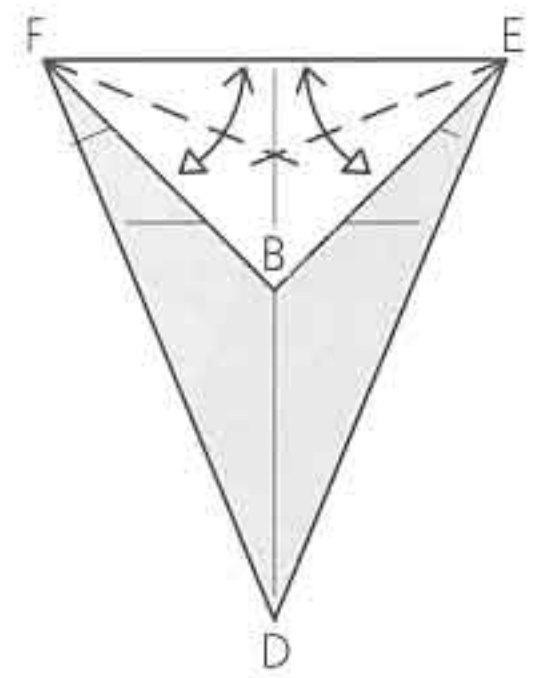

6 Fold edge BF up to the top edge EF and unfold. Repeat on the right with edge BE.

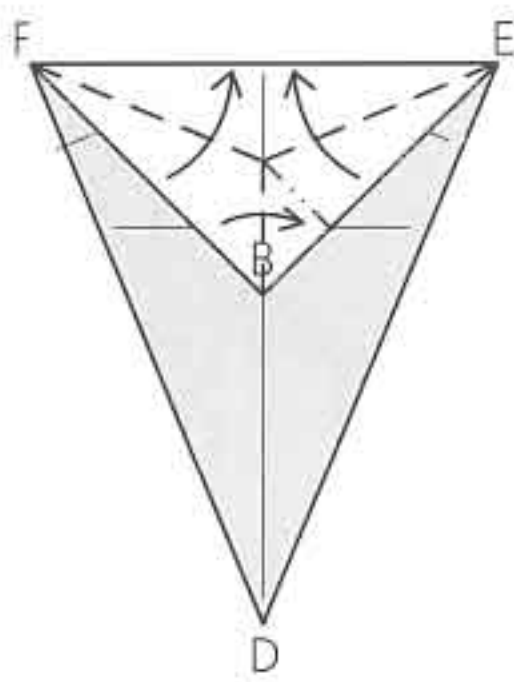

7 Fold a rabbit ear from flap B.

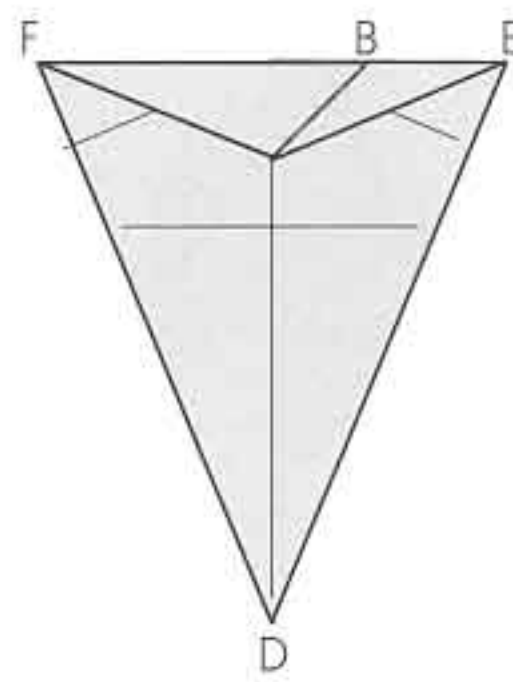

8 Turn over the model.

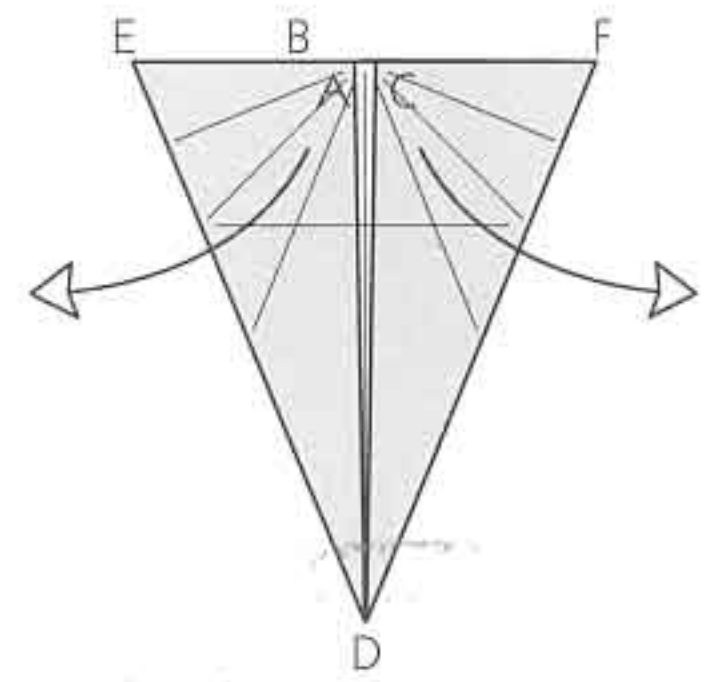
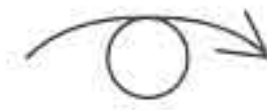

9 Unfold flaps A and C.

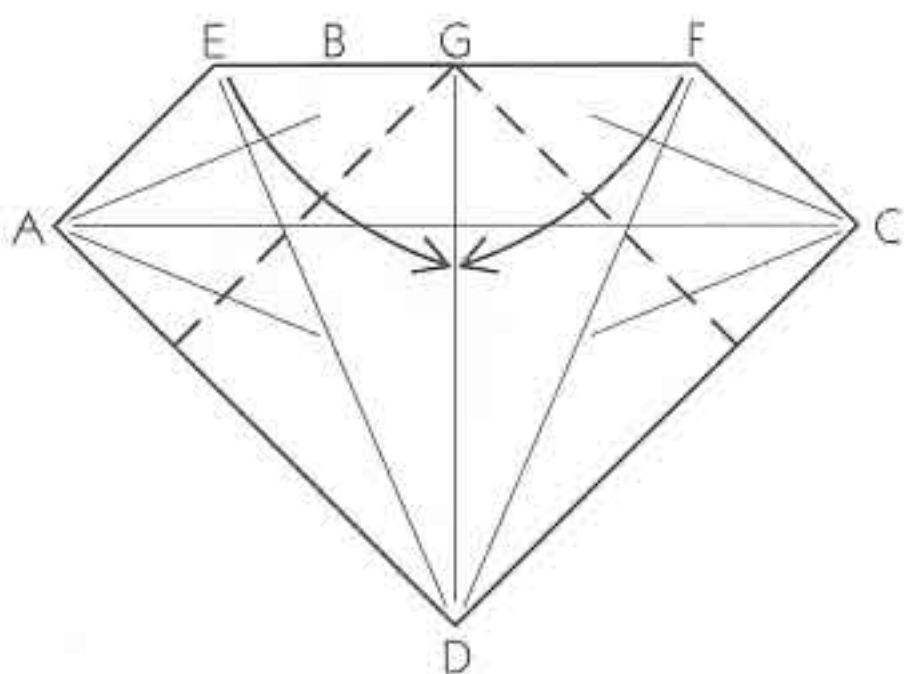

10 Fold edges EG and GF down to meet along the center line.

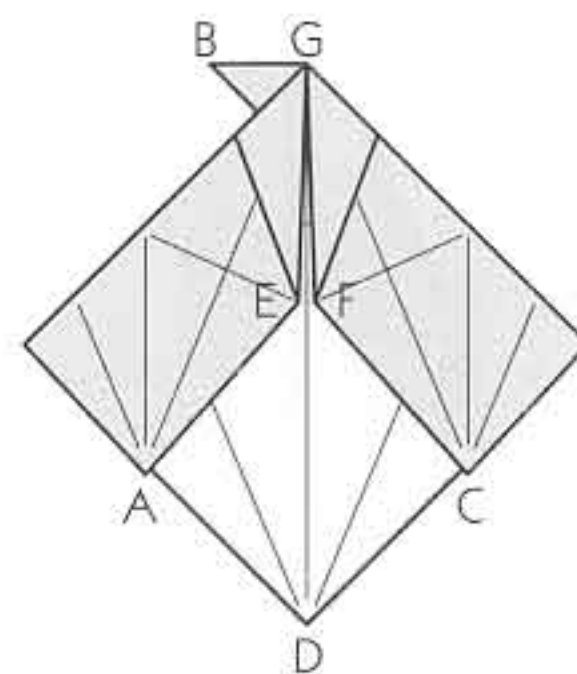

11 Turn over the model.

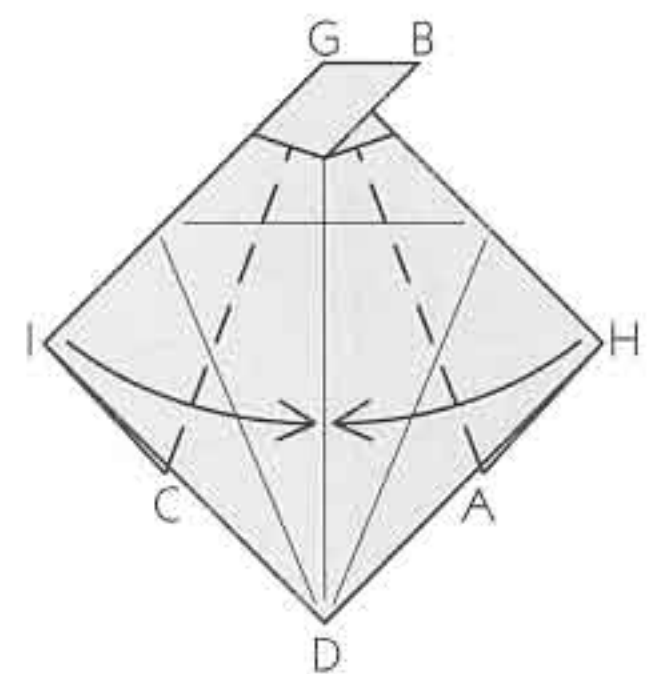

12 Fold in edges IG and HG to meet along the center line. Note that the folds run all the way to point G, up under the little hood.

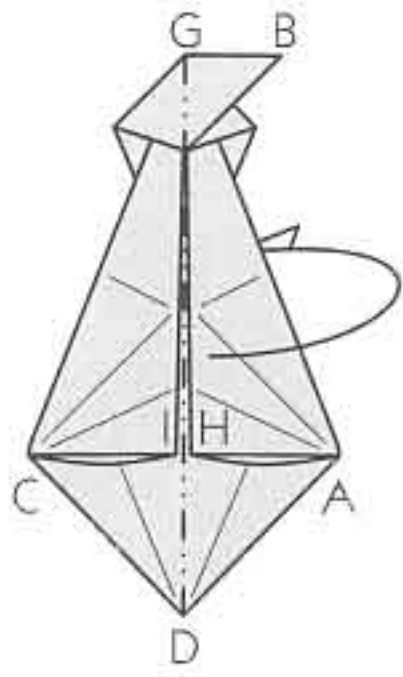

13 Mountain-fold the right side of the model behind.

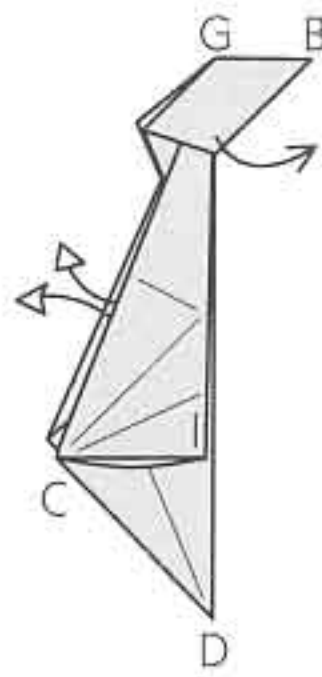

14 Pull the loose layers of paper out of the left side of the model and swivel point B upward and to the right.

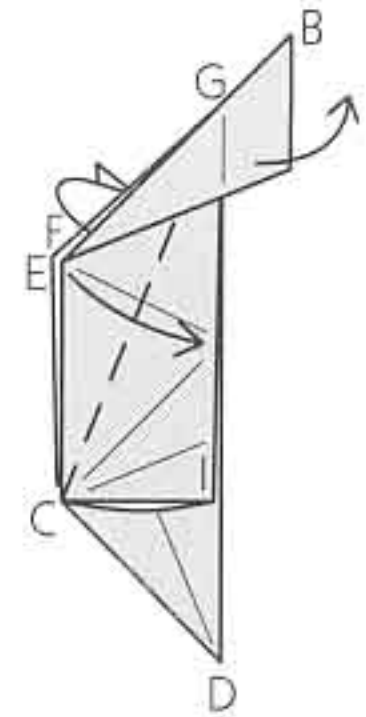

15 Fold corners E and F down to edge GD and swivel point B farther upward.

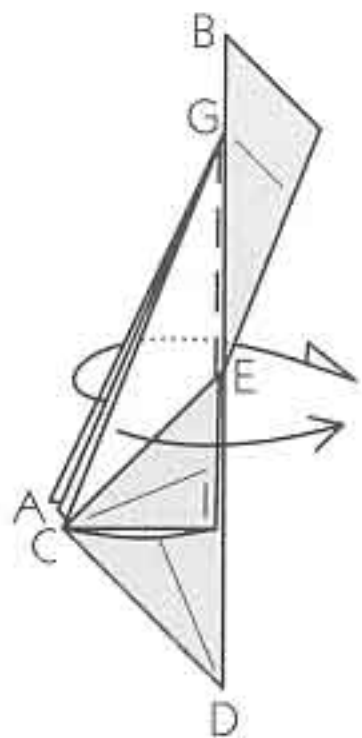

16 Fold corners A and C to the right. Be careful to keep point E (and the corresponding point behind) in place.

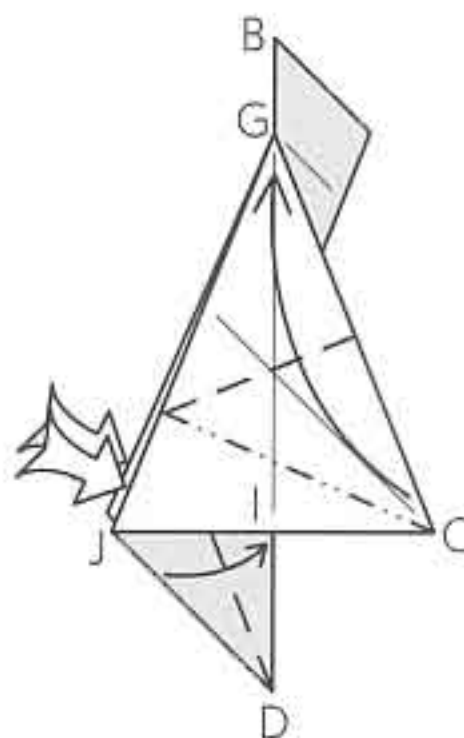

17 Simultaneously fold corner C up to point G and squash-fold corner J in a swivel fold. Repeat behind.

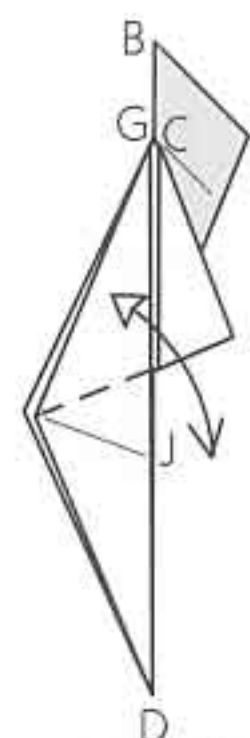

18 Fold and unfold. Repeat behind.

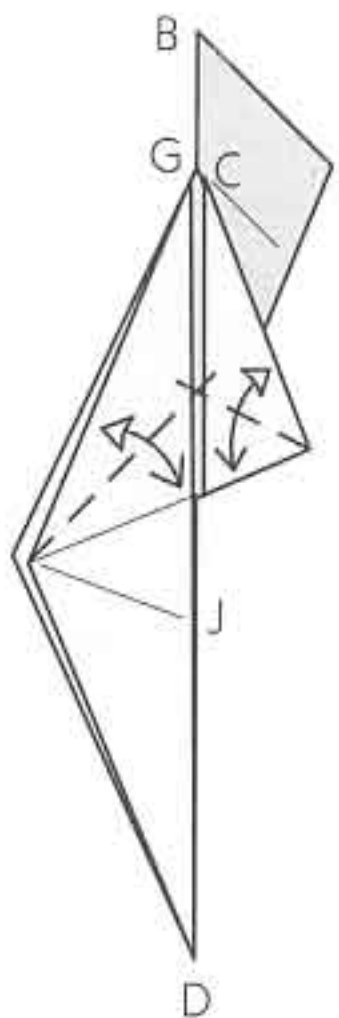

19 Crease flap C along two angle bisectors. Repeat behind.

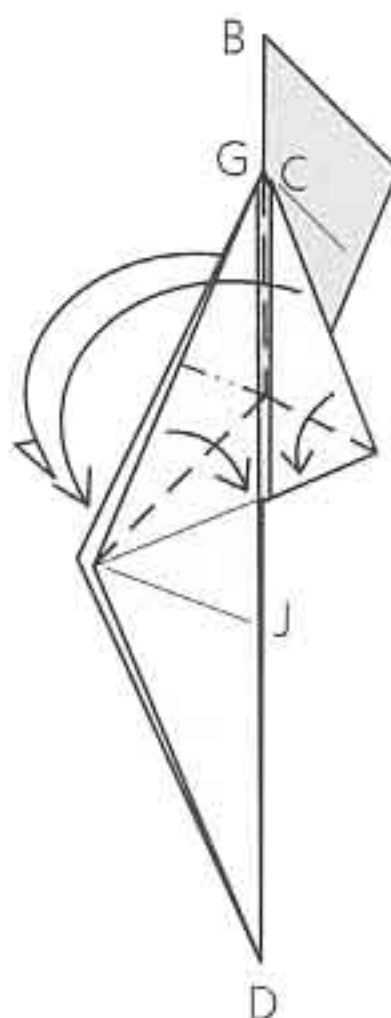

20 Fold a rabbit ear from flap C. Repeat behind.

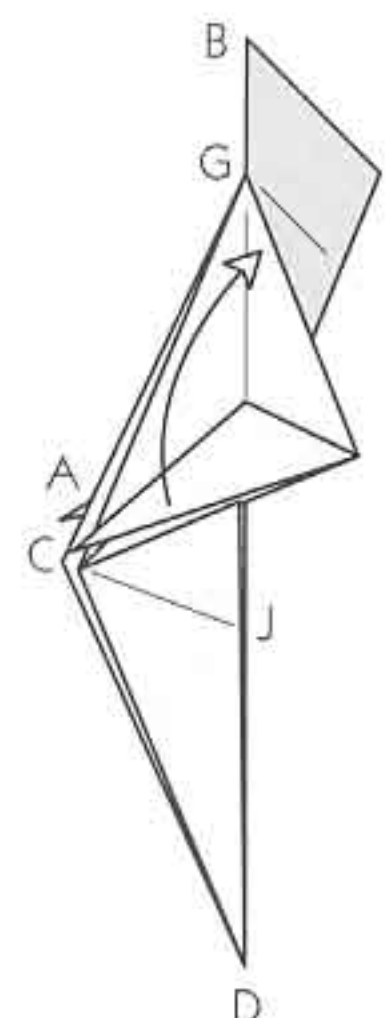

21 Unfold flap C. Repeat behind.

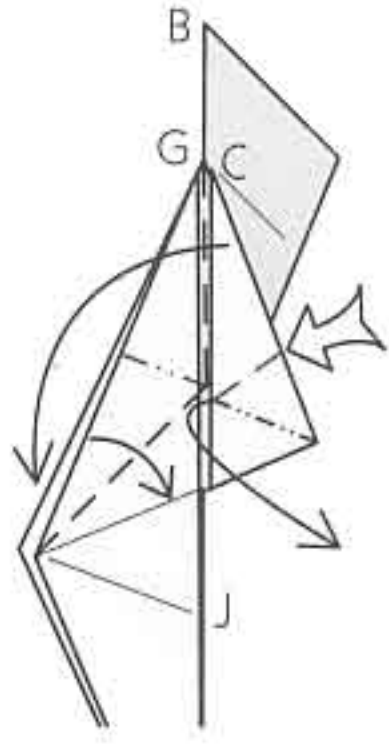

22 Re-fold the rabbit ear, but pull the right raw edge of the paper as far out as possible as you refold it.

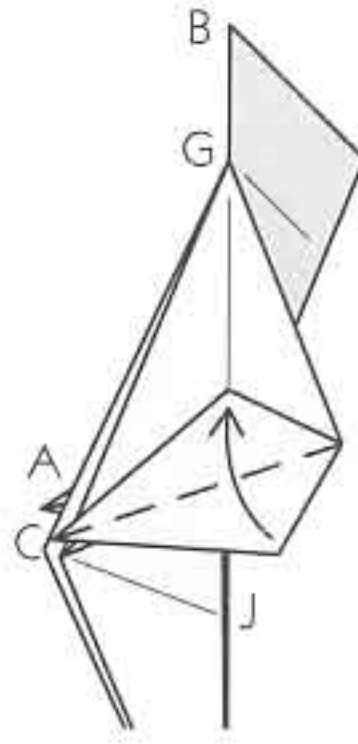

23 Fold the raw edge upward on an existing crease.

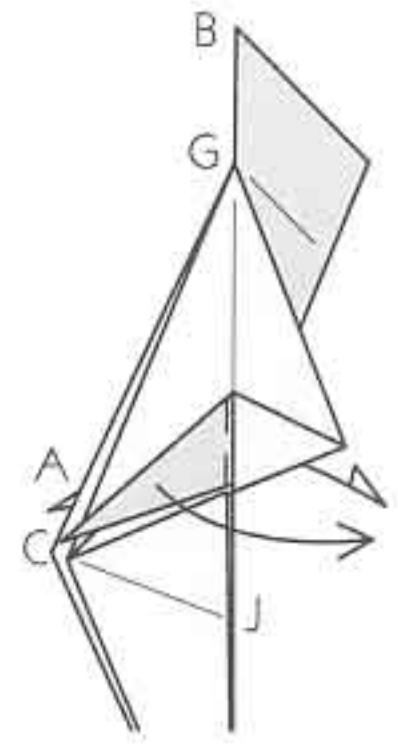

24 Fold point C to the right. Repeat behind with point A.

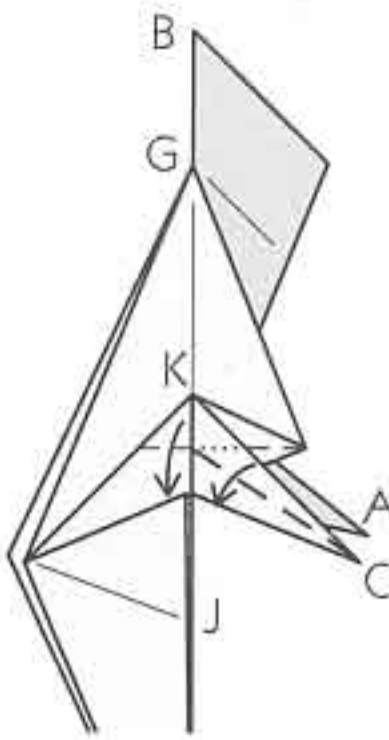

25 Fold point C in half while you fold point K down; you must do these two folds simultaneously. Repeat behind on point A.

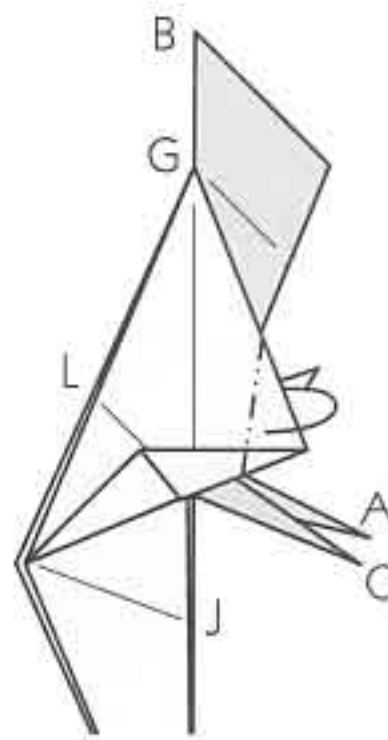

26 Fold the corner inside. Repeat behind.

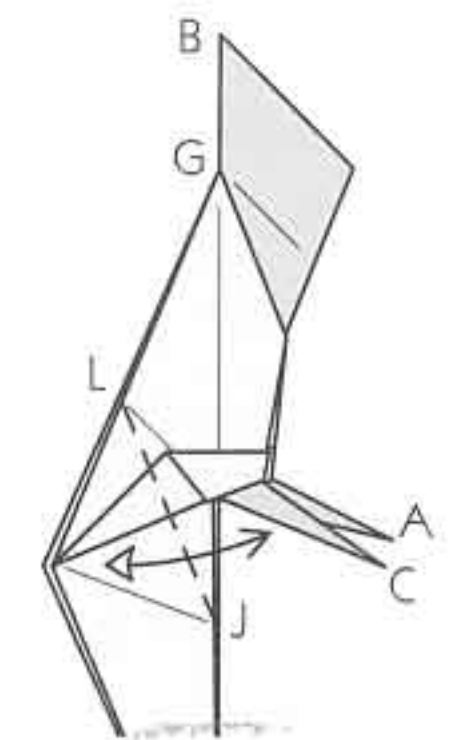

27 Make a crease that runs from point L to point J through the near layer. Repeat behind.

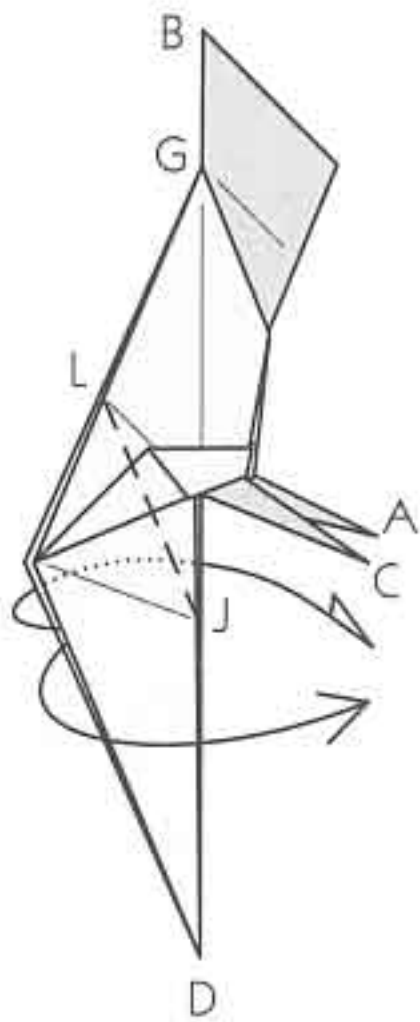

28 Outside-reverse-fold point D to the right on the creases you just made.

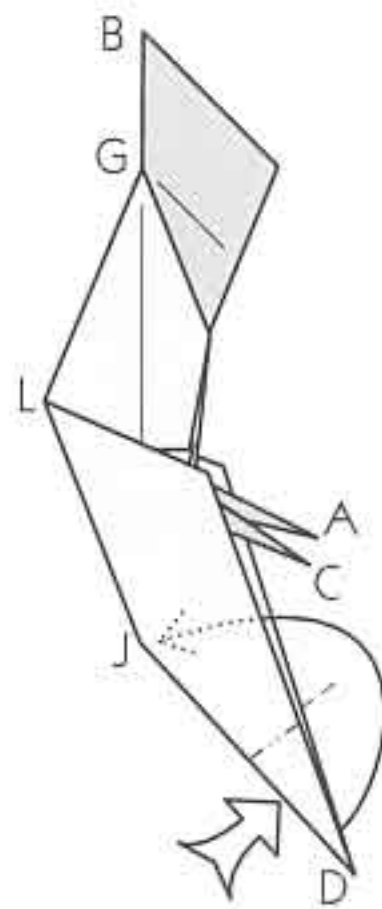

29 Reverse-fold point D inside to point J.

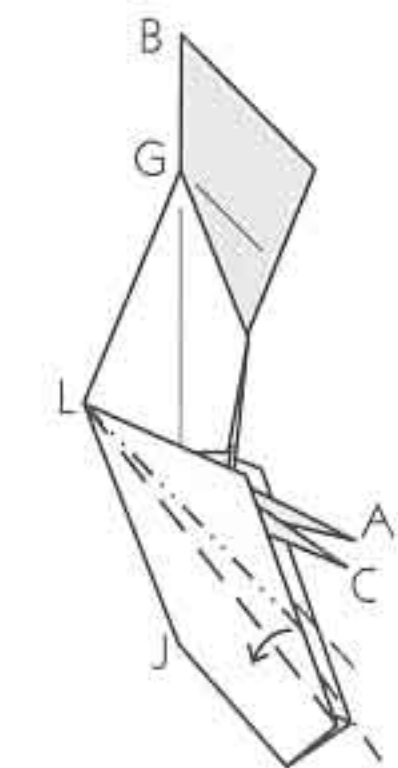

30 Pleat the near layer of the tail. Repeat behind.

Australian forest

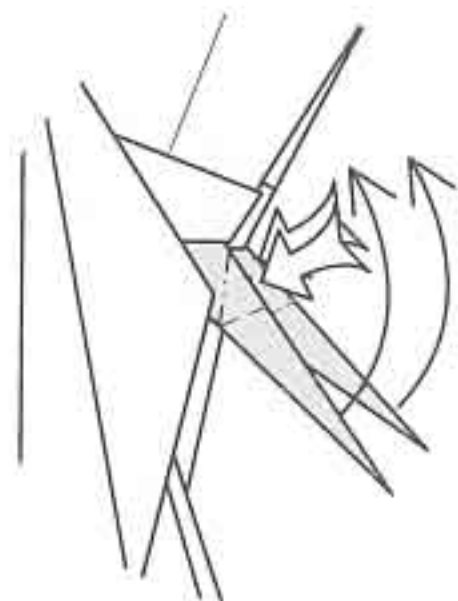

31 Crimp the feet upward.



32 Reverse-fold each foot twice so that it points downward.

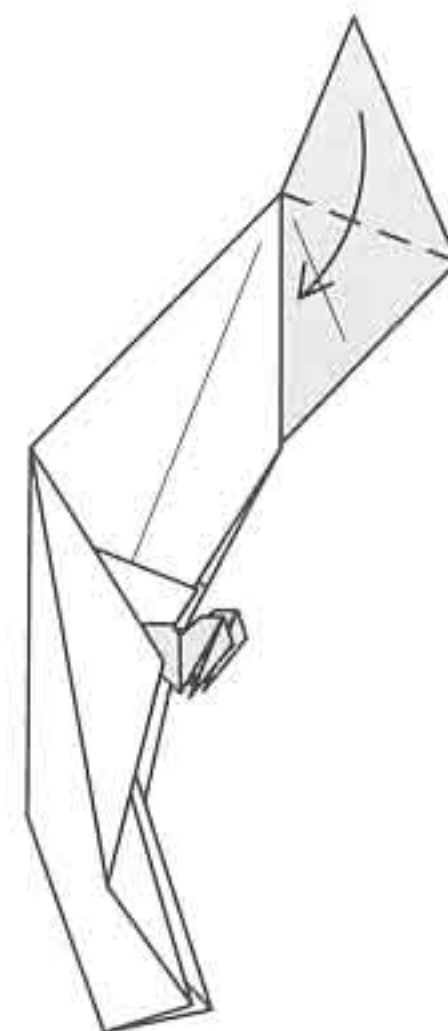

33 Enlarged view of head. Fold the top point down.

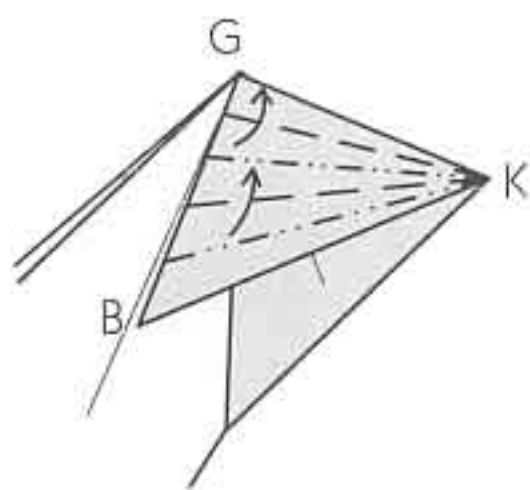

34 Pleat edge BK up to edge GK. The exact number of pleats isn't important, but each crease should run all the way to point K.

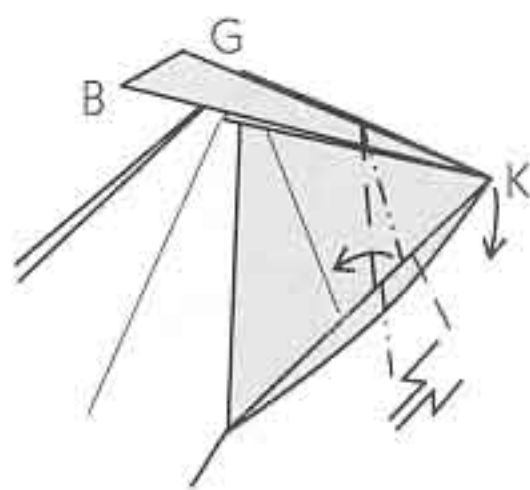

35 Crimp point K downward.

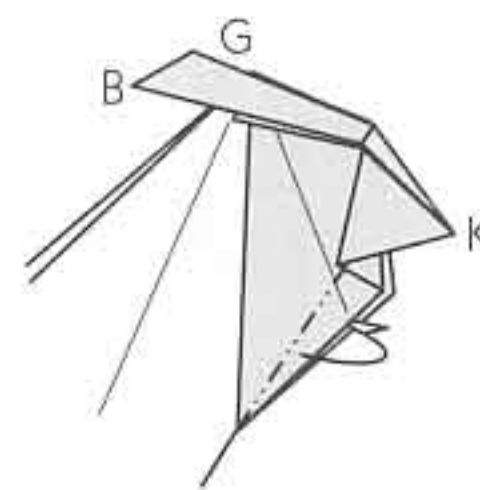

36 Fold the edge under the beak inside. Repeat behind.

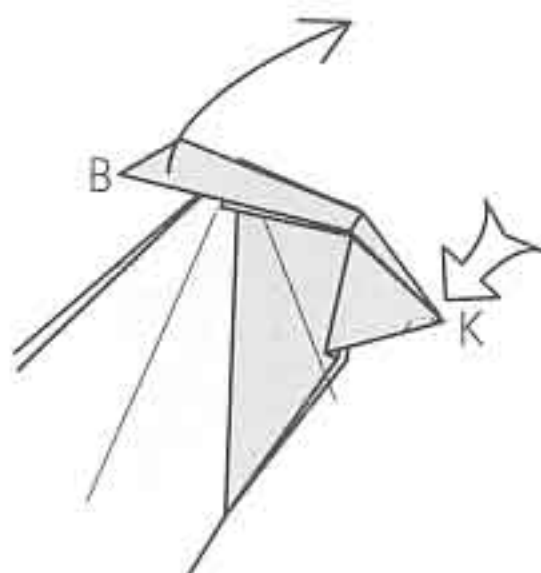

37 Push the tip of the beak down slightly. Lift up the crest (point B) and fan out the pleats.



38 Put your finger in the slot in the belly and open out the back to make the body three-dimensional.

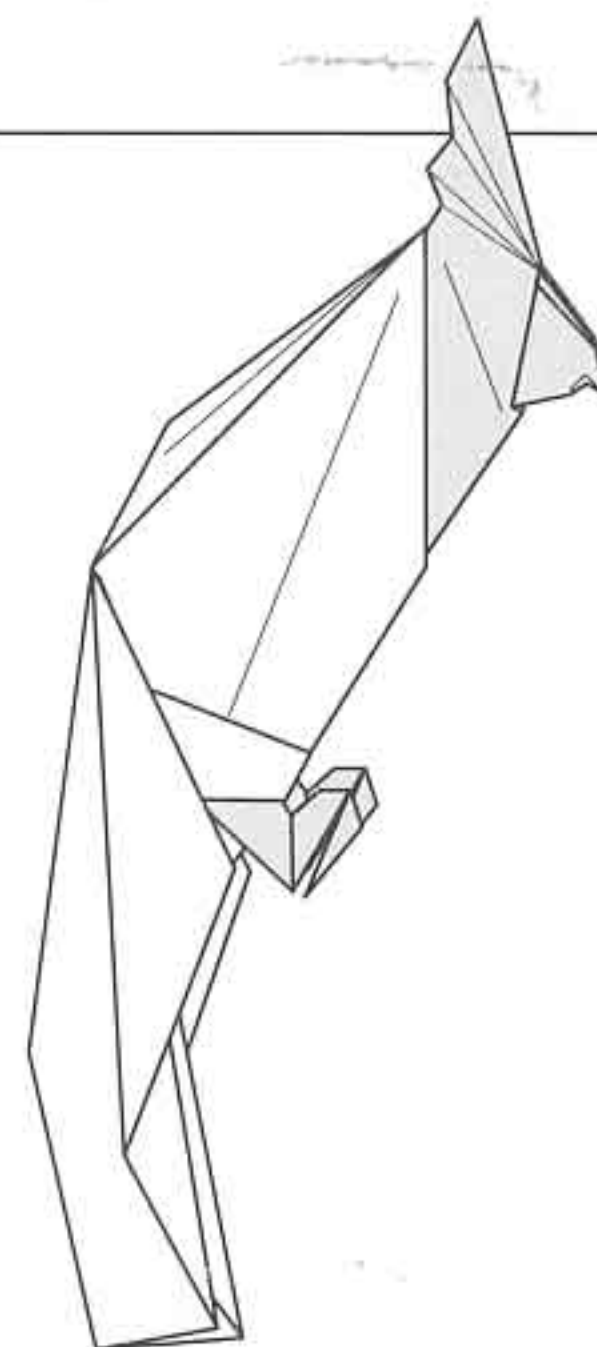

Finished Cockatoo.

◆ African savanna ◆

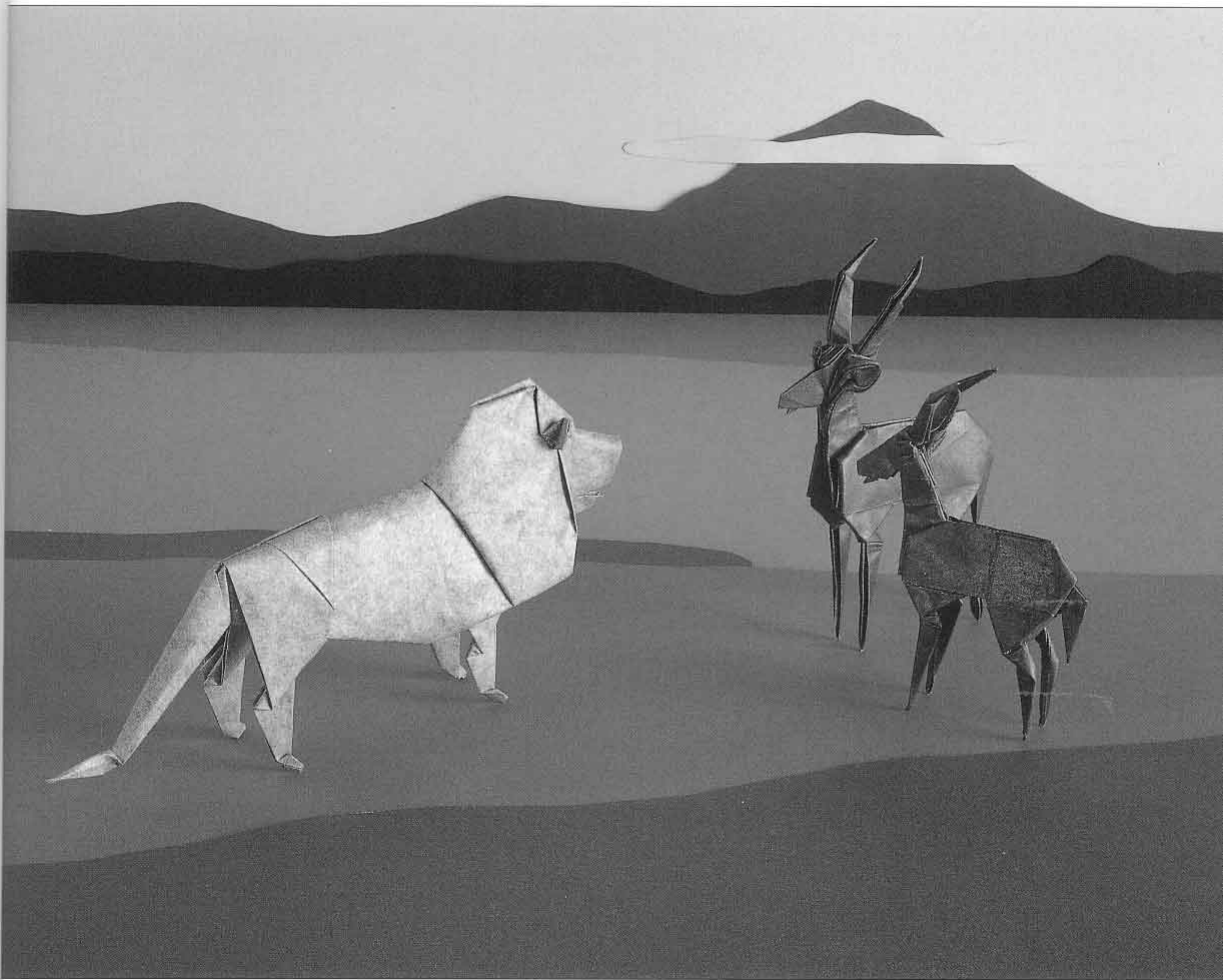

For this project, you will fold the following models:

Name	Page	Rating	Paper requirements
Lion	96	Difficult	16 in (40 cm) square of thin yellow paper
Gazelle	104	Difficult	12 in (30 cm) square of thin brown paper

◆ lion ◆

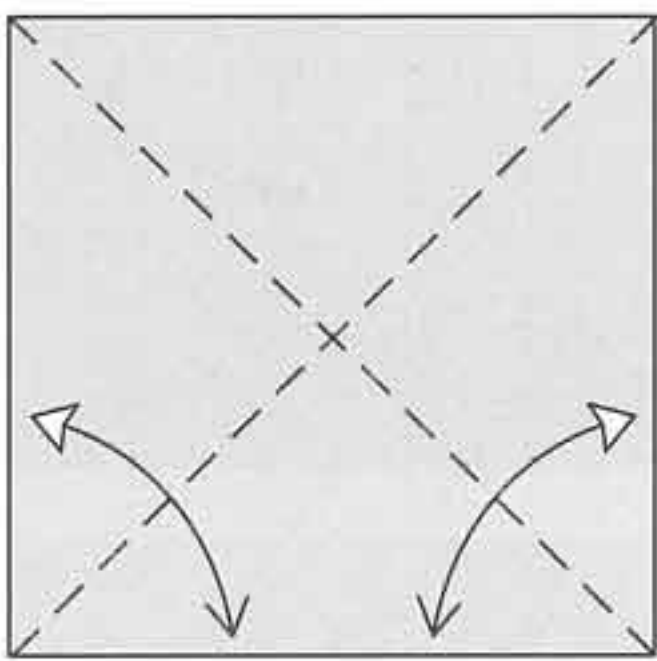
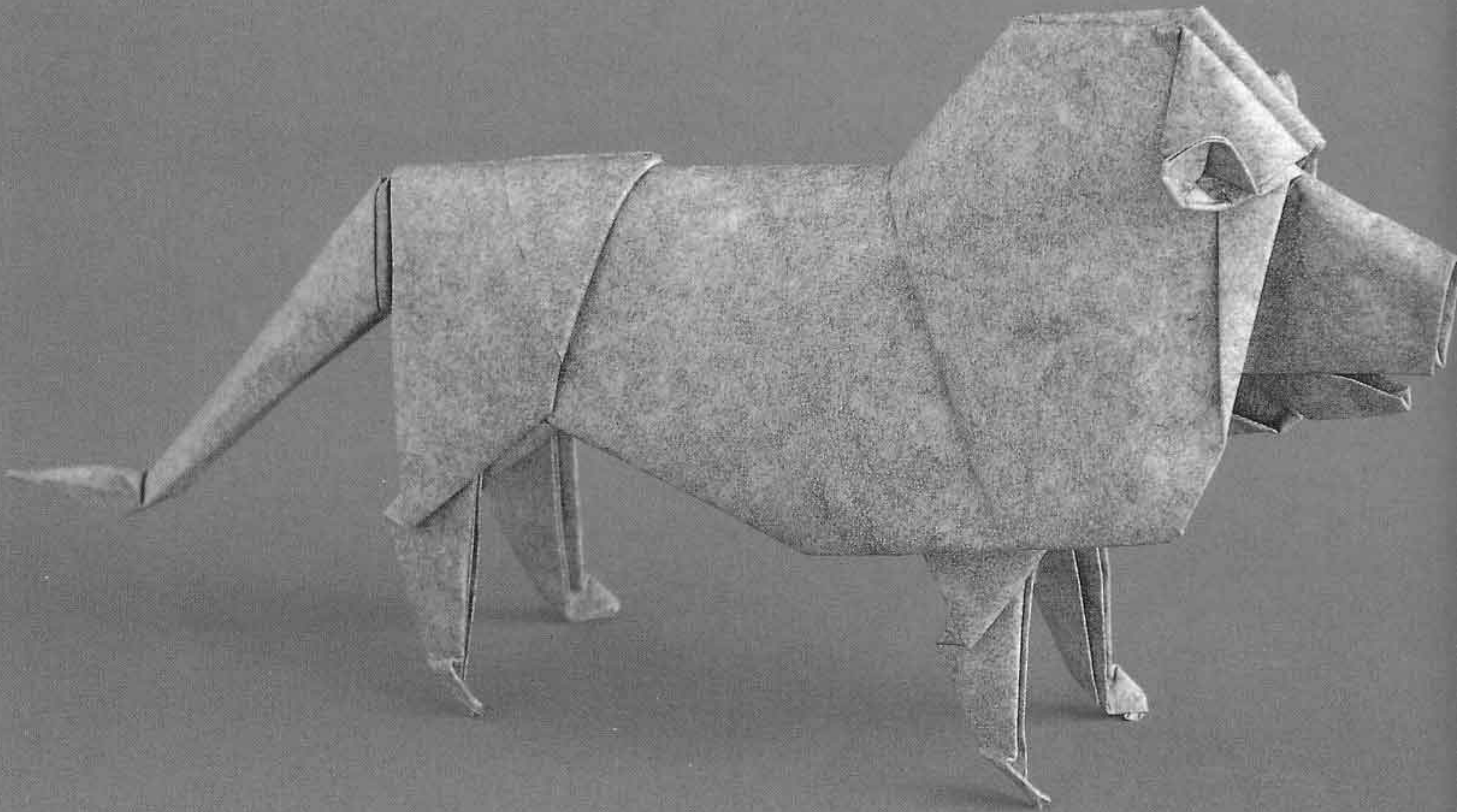

1 Begin with the colored side up. Fold the paper in half along the diagonals and unfold.

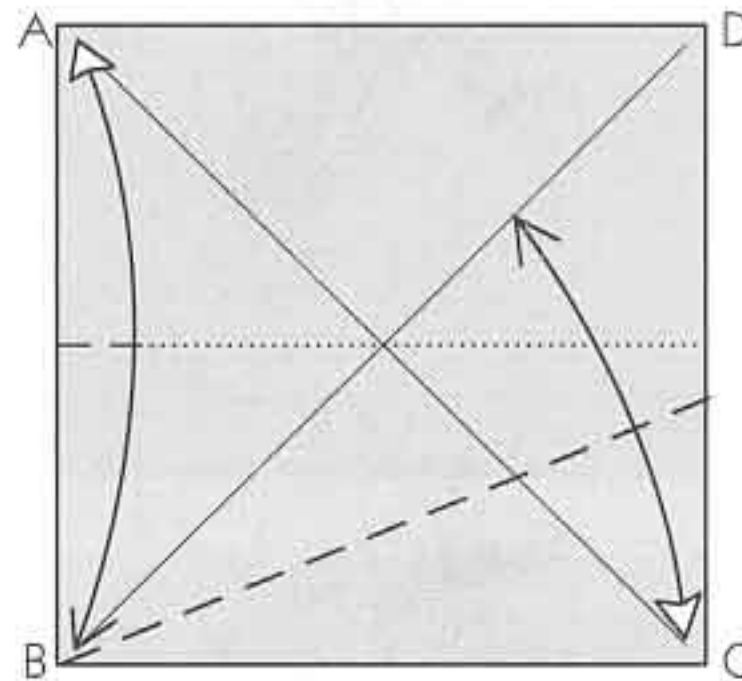

2 Fold edge BC up to lie along the diagonal BD and unfold. Then fold corner A down to corner B, making the crease sharp only where it hits the left edge AB.

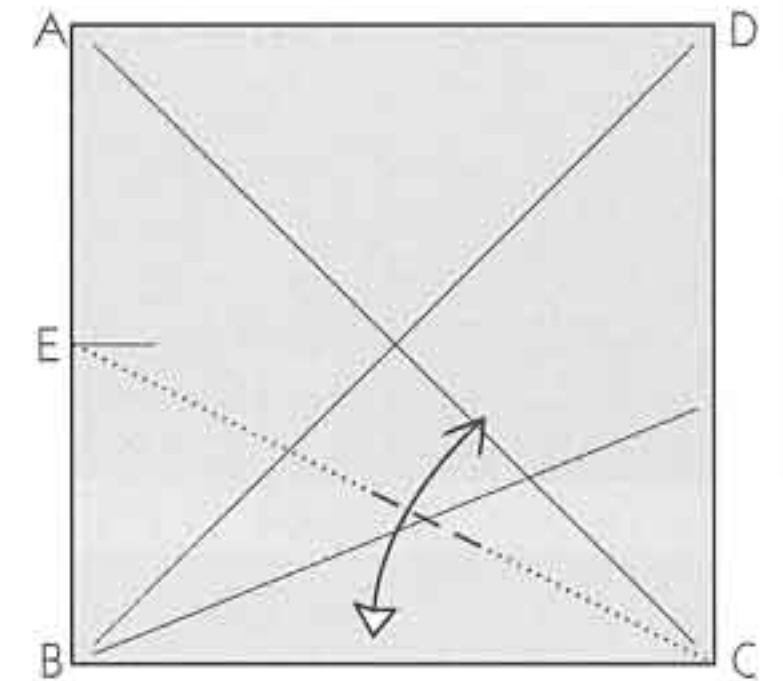

3 Fold corner B up so that the crease runs from corner C to point E and unfold, making the crease sharp only where it crosses the crease you just made.

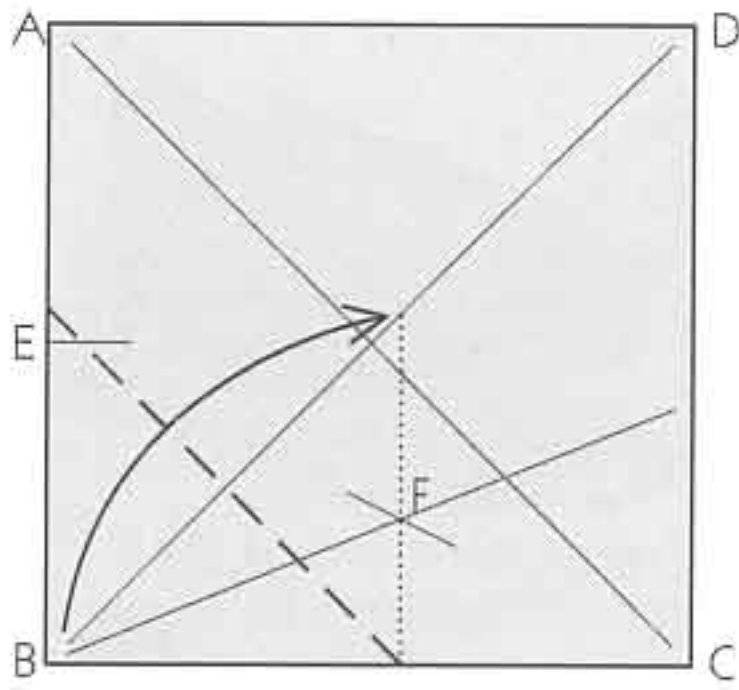

4 Point F marks the intersection of the two creases you just made. Fold corner B up to lie on the diagonal BD while the edge BC runs through point F.

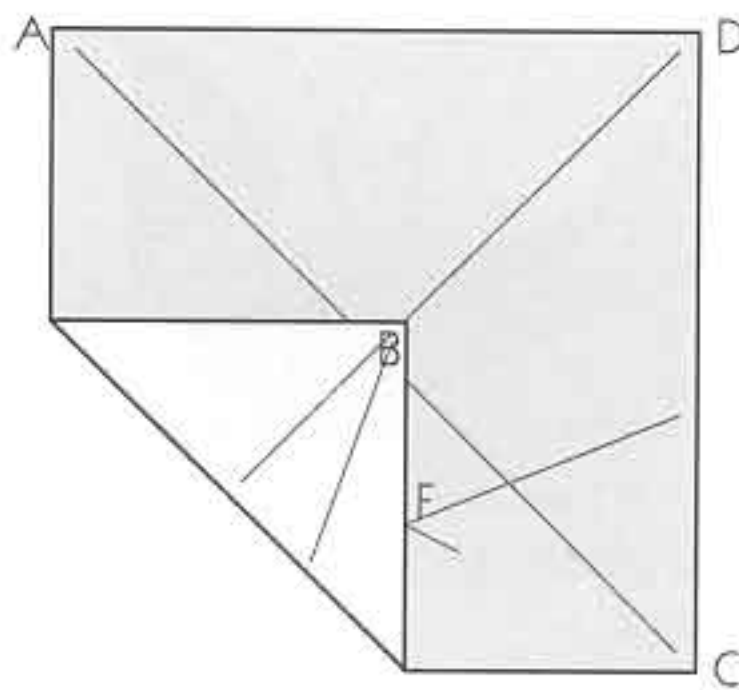

5 Turn over the paper.

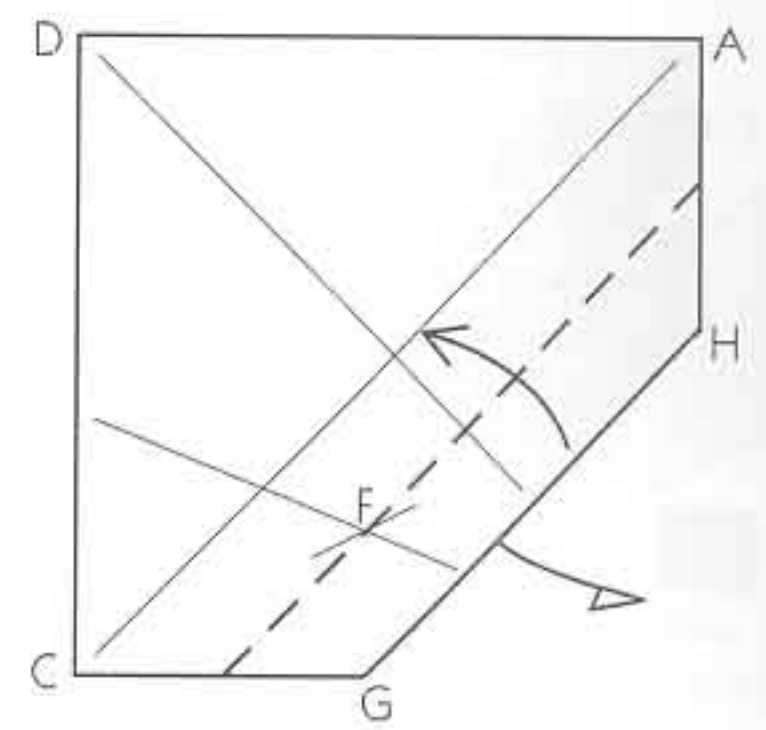
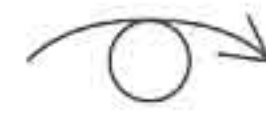

6 Fold edge GH to lie along diagonal CA, allowing corner B to flip out from behind.

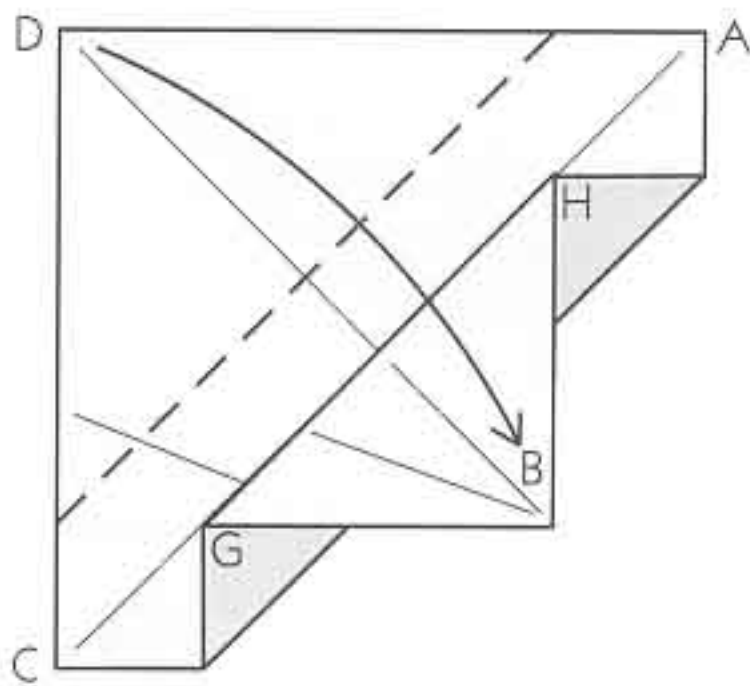

7 Fold down corner D to line up with point B.

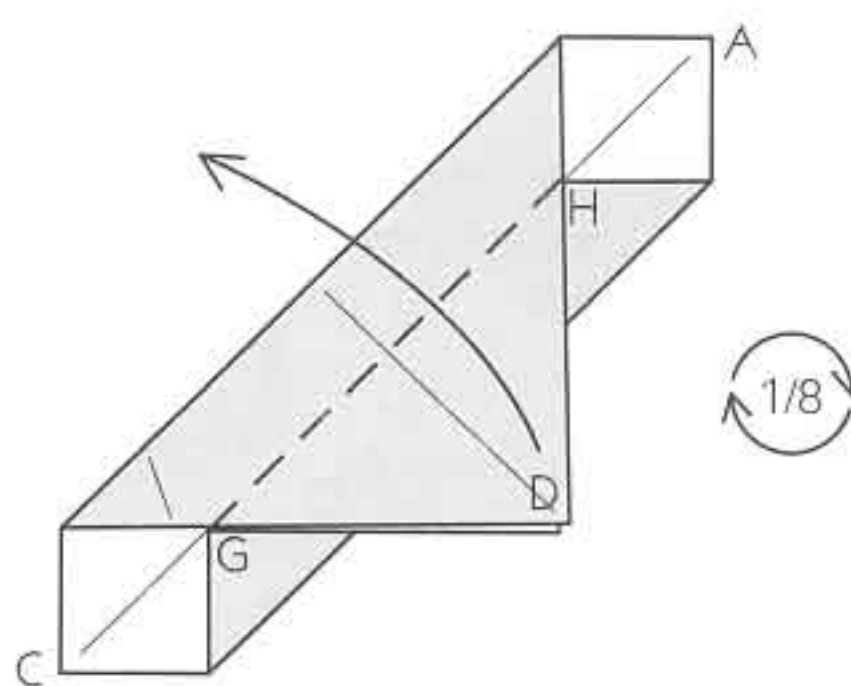

8 Fold corner D back up along crease CA and rotate the model 1/8 turn clockwise.

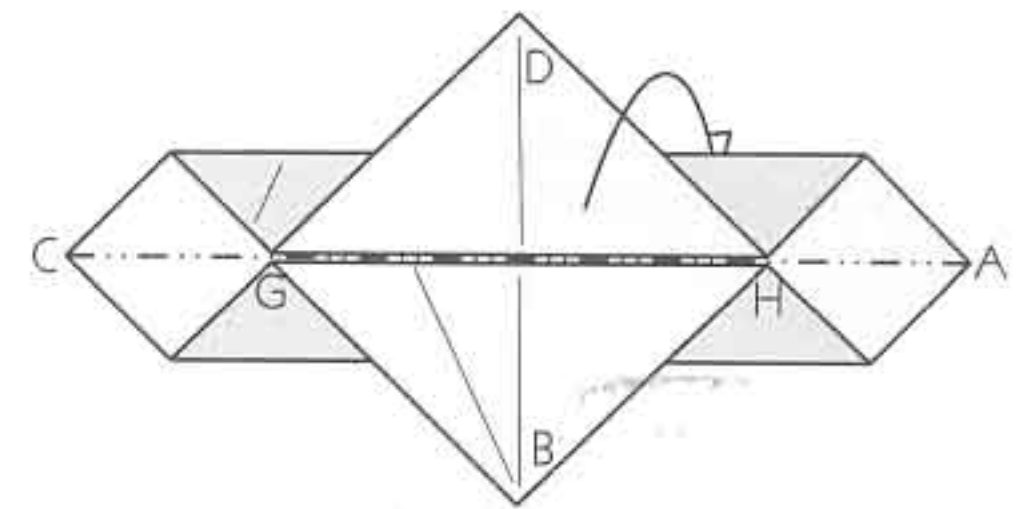

9 Mountain-fold the top half of the model behind and along AC.

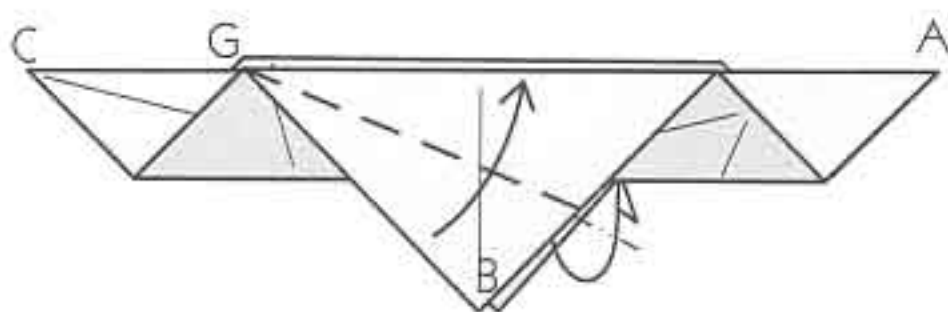

10 Fold up edge GB to lie along edge CA. Repeat behind.

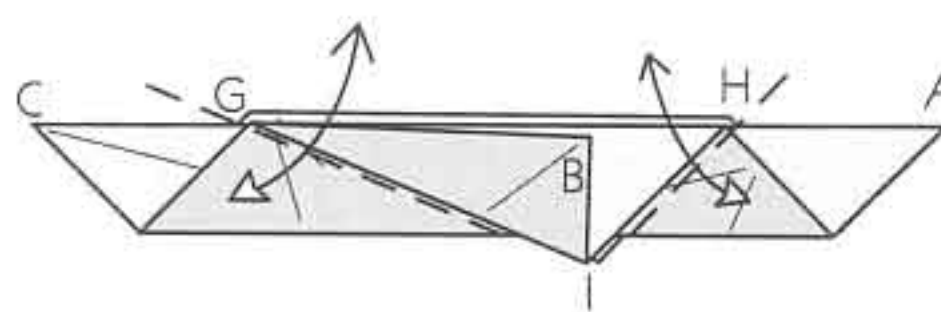

11 Crease through all layers along edges GI and HI. Repeat on the other side.

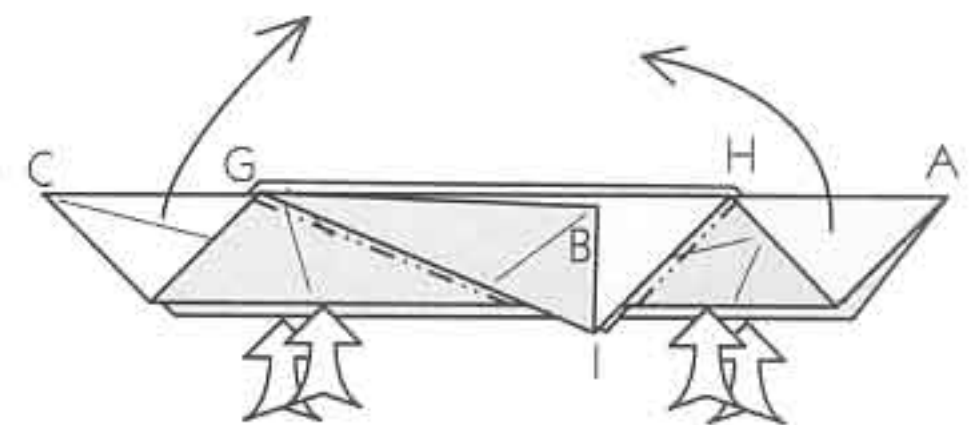

12 Reverse-fold corners C and A upward; you must simultaneously reverse-fold both of the bottom edges on each side.

African savanna

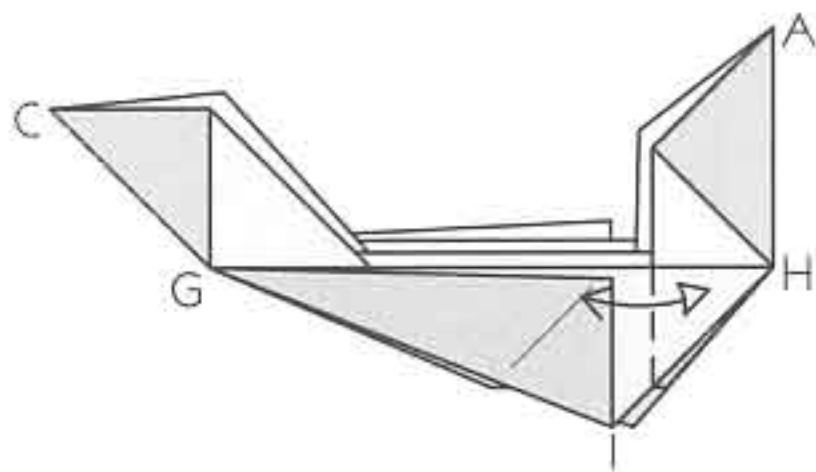

13 Fold corner H to the left and unfold. Repeat behind.

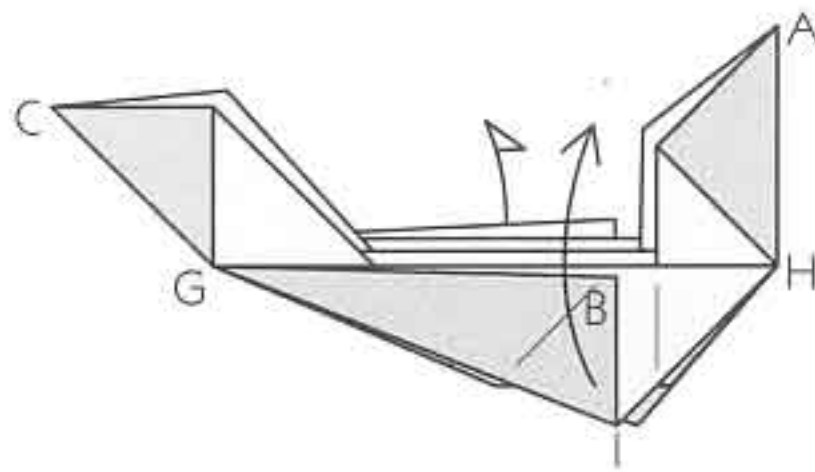

14 Fold corner I up; repeat behind.

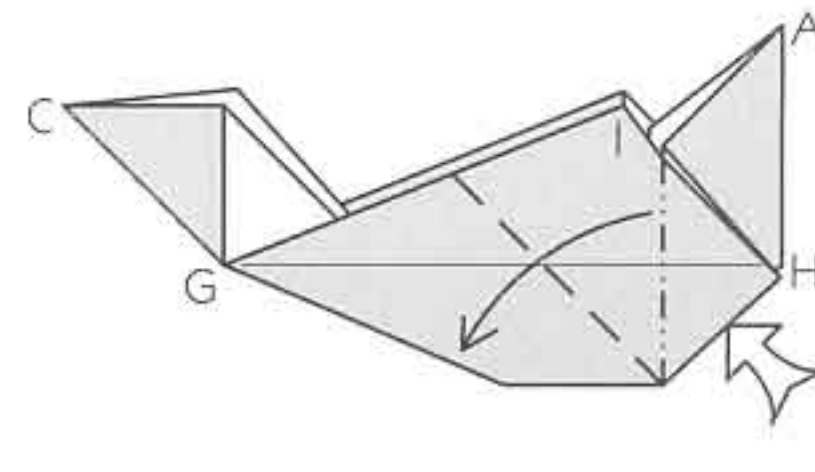

15 Squash-fold corner H; the mountain fold forms on the crease you made in step 13. Repeat behind.

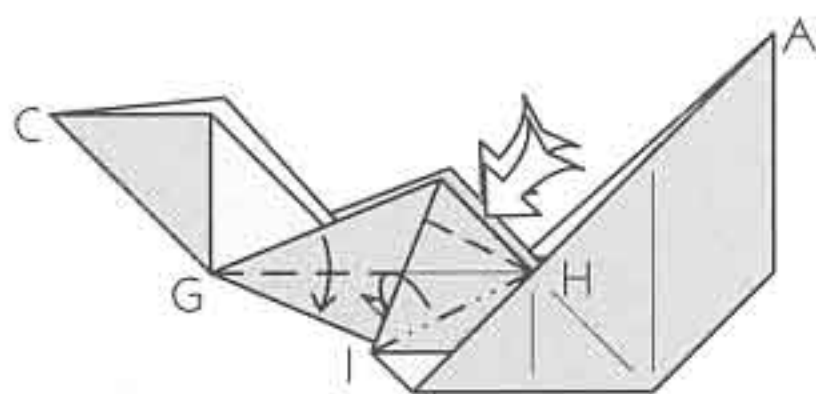

16 Reverse-fold the edge, tucking the excess paper above corner I behind corner I. Repeat behind.

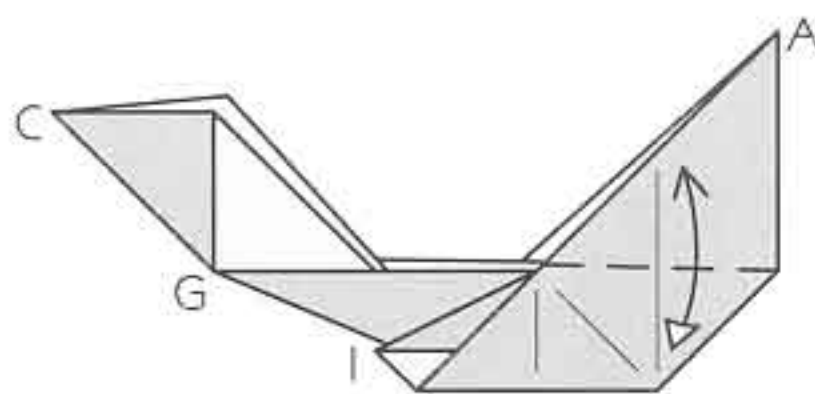

17 Fold the bottom edge up and unfold. Repeat behind.

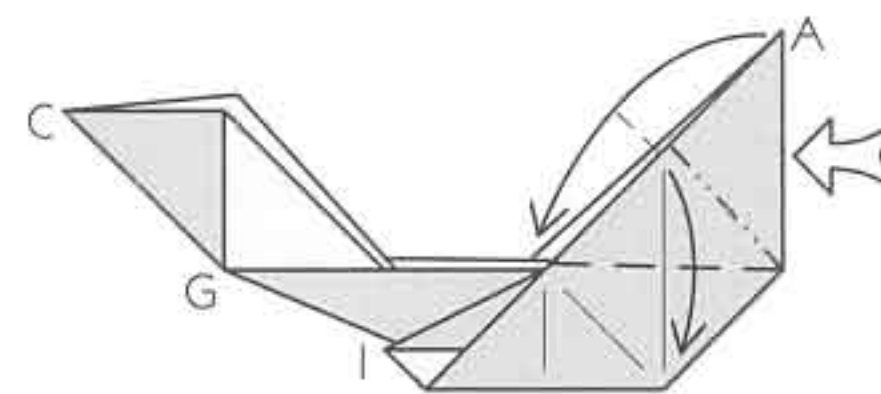

18 Squash-fold corner A.

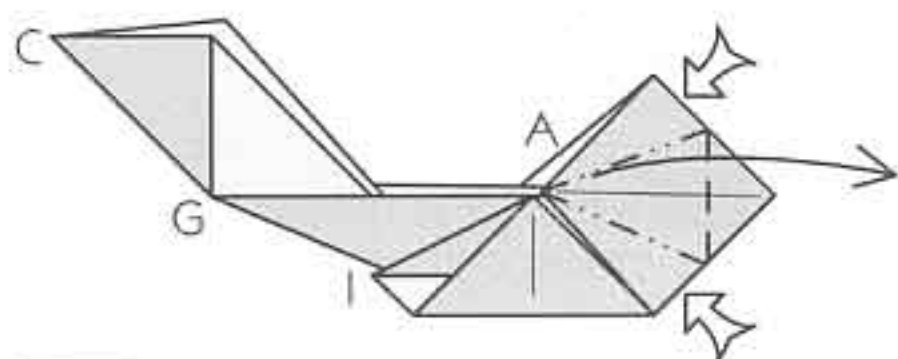

19 Petal-fold corner A.

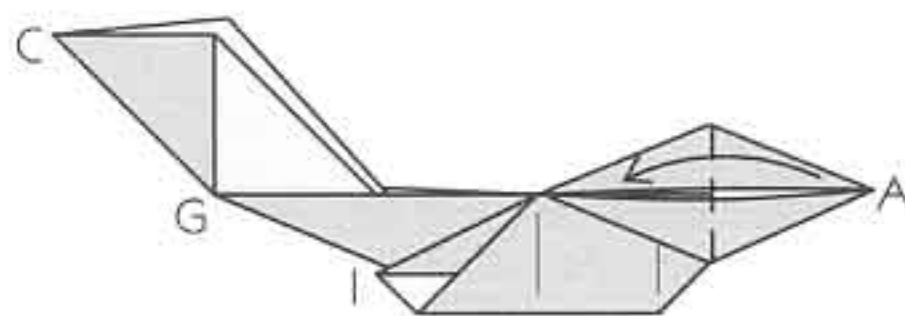

20 Fold point A back to the left.

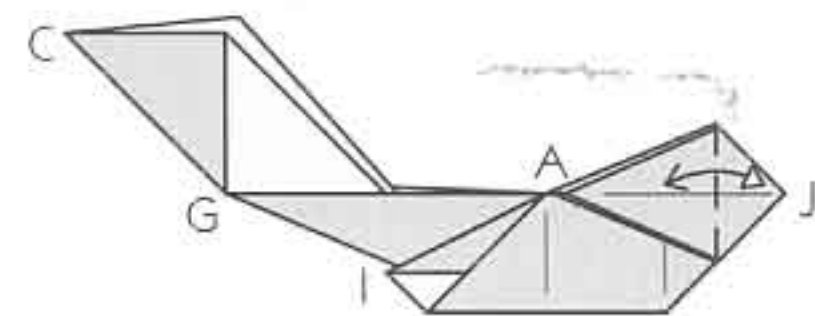

21 Fold point J in and unfold, creasing through all layers.

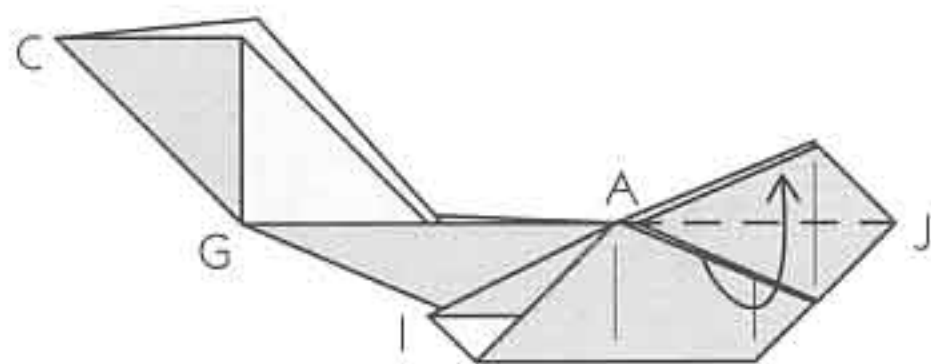

22 Fold a layer up.

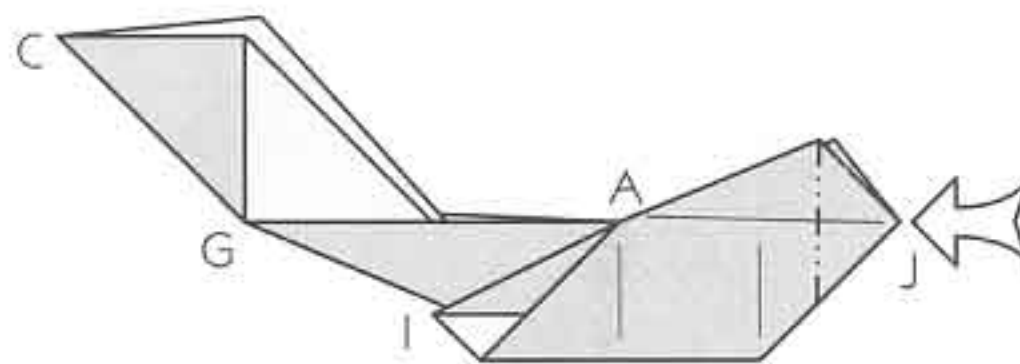

23 Sink corner J by opening it out flat and pushing the point inside the remaining layers.

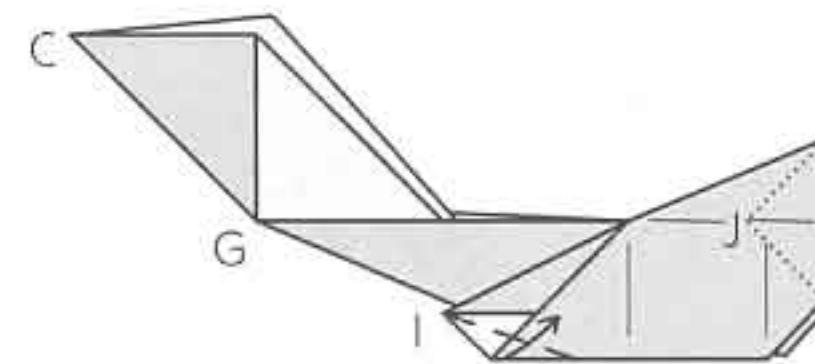

24 Fold the corner up so that the raw edges meet. Repeat behind.

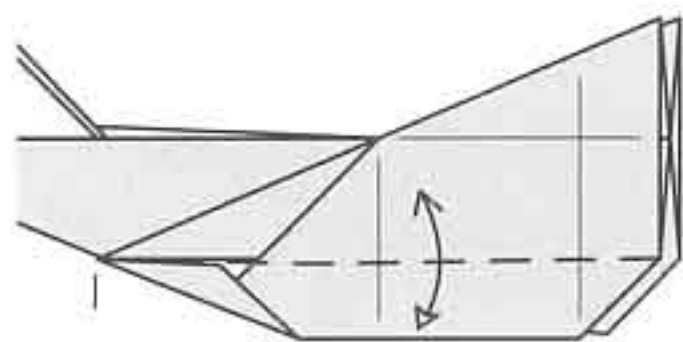

25 Fold the bottom edge up and unfold, creasing through all layers. Repeat behind.

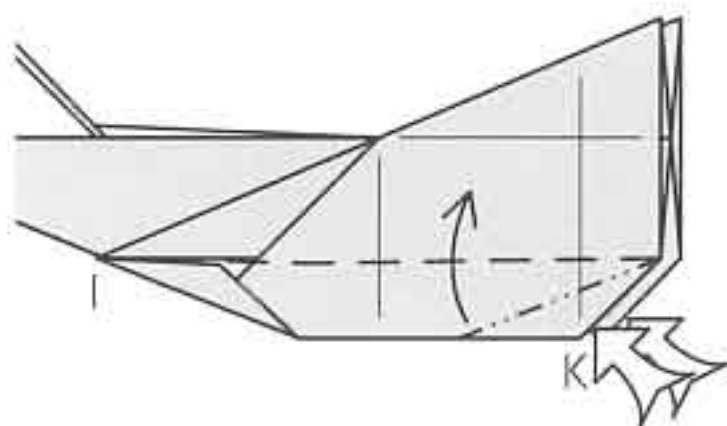

26 Spread-sink corner K as you fold the bottom edge up. Repeat behind.

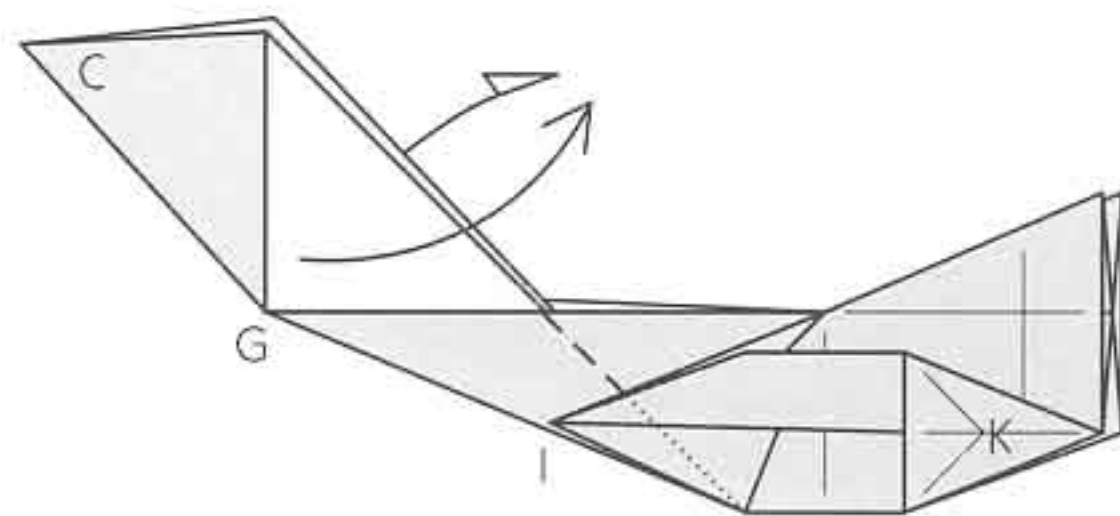

27 Fold corner G up to the right. Repeat behind.

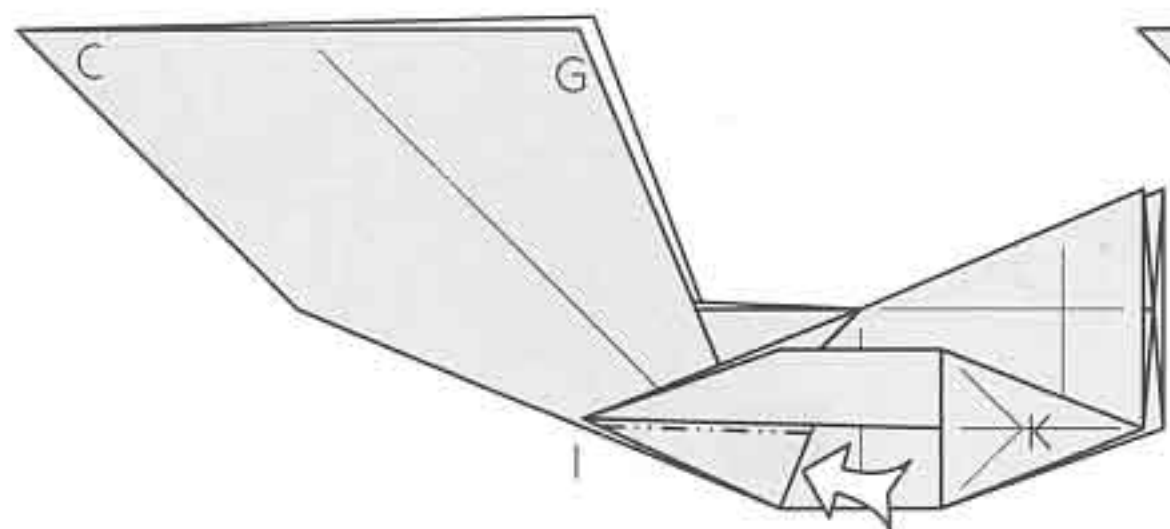

28 Reverse-fold the edge. Part of the reverse fold runs behind flap G. Repeat behind.

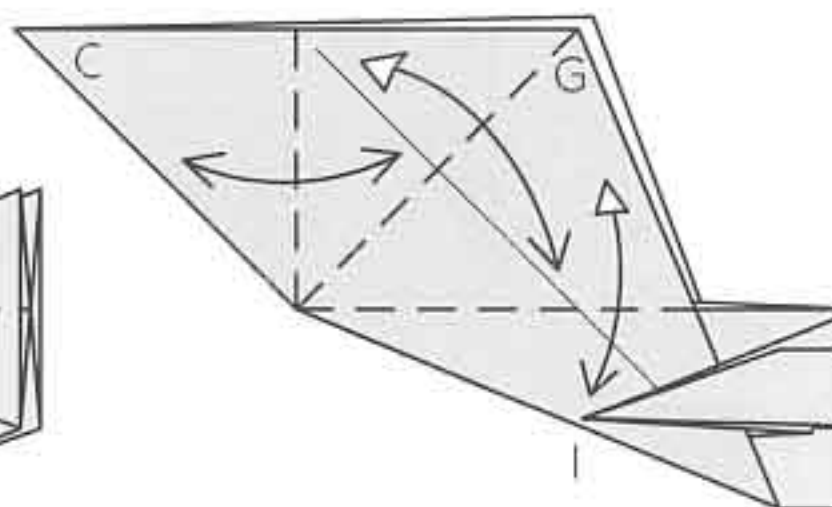

29 Fold and unfold on both sides of the paper.

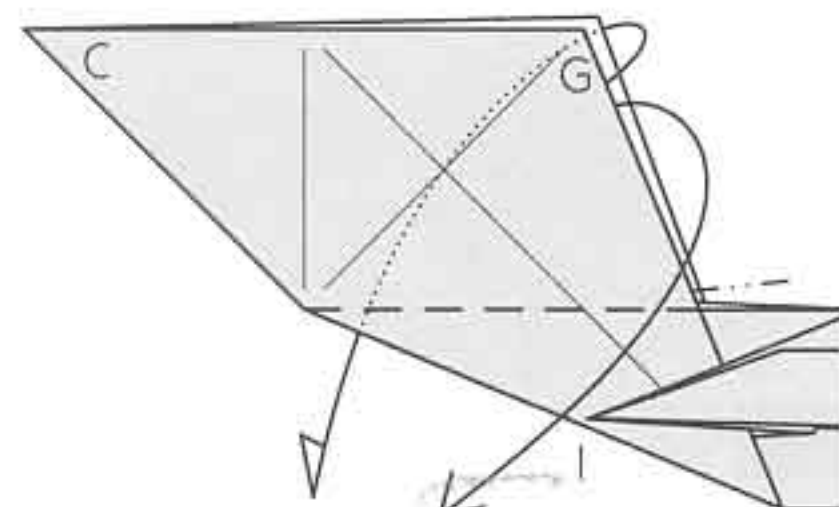

30 Turn flap C inside-out.

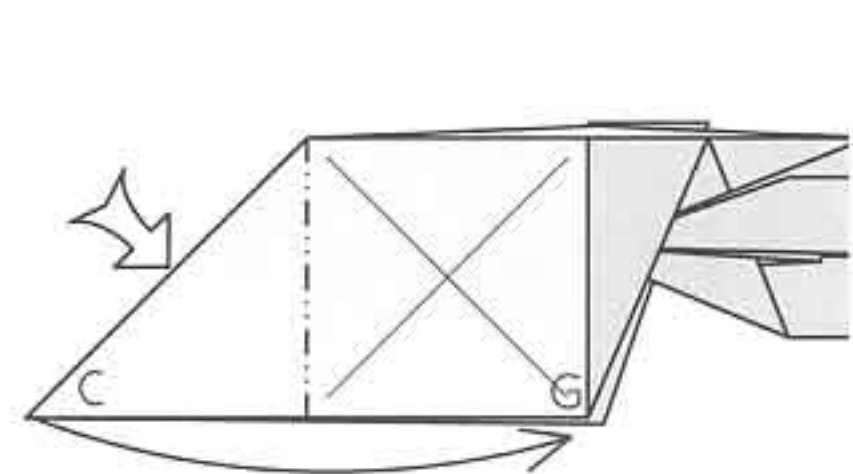

31 Reverse-fold flap C to point G.

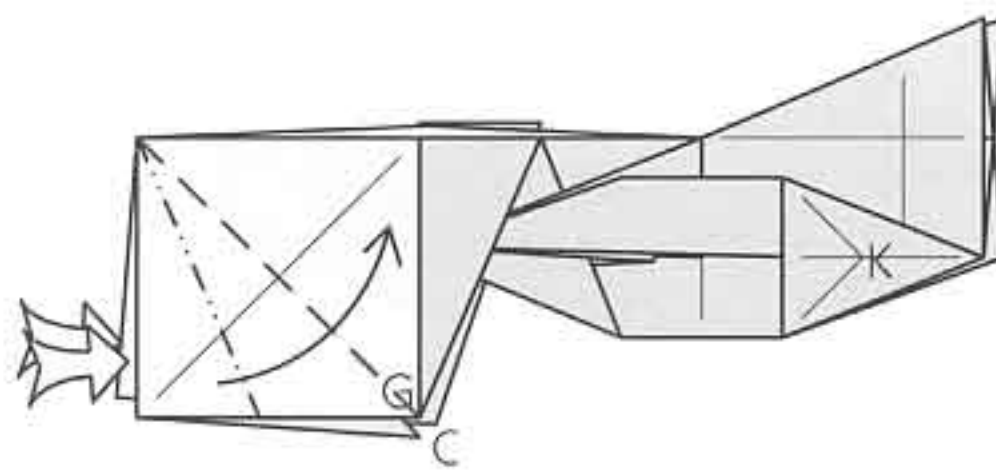

32 Squash-fold the left edge; repeat behind.

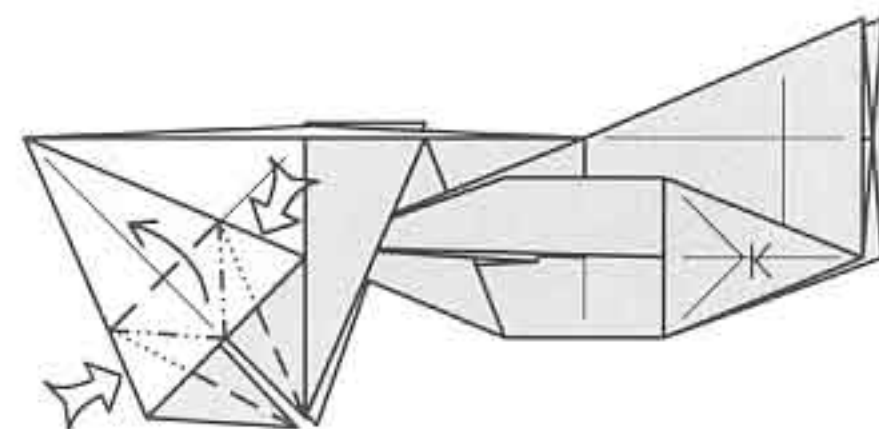

33 Petal-fold the edge. Repeat behind.

African savanna

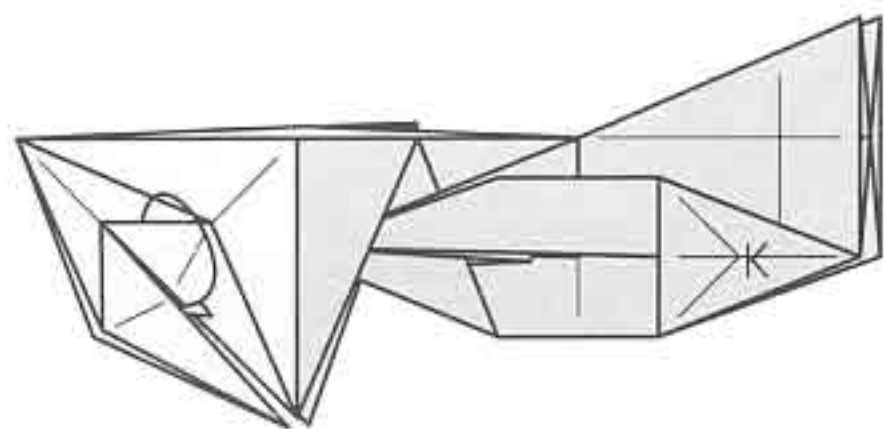

34 Tuck the petal fold inside.

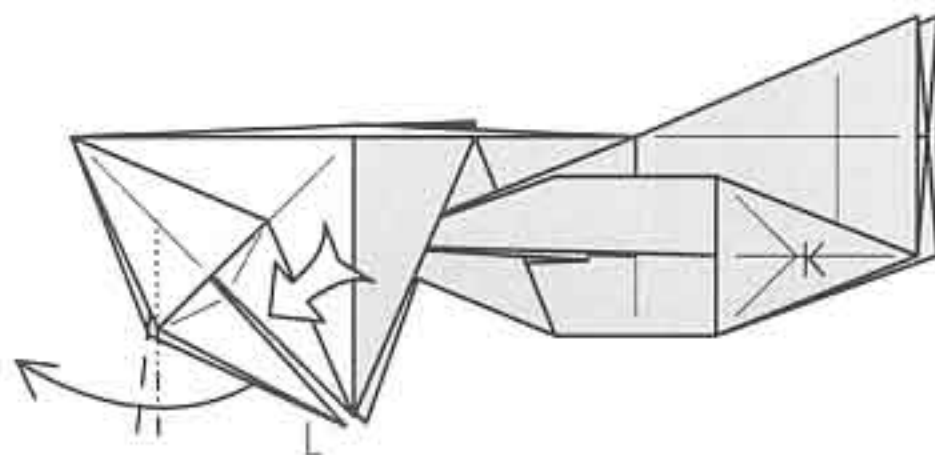

35 Reverse-fold point L as far as possible to the left.

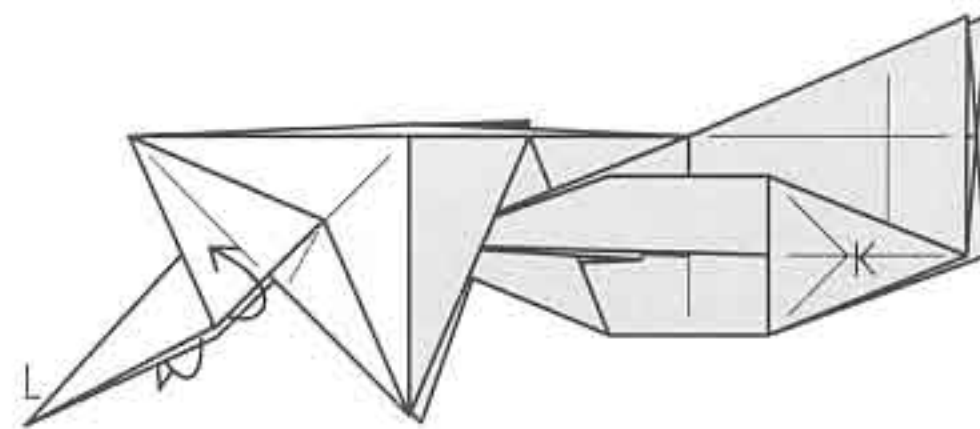

36 Wrap one layer to the front. Repeat behind.

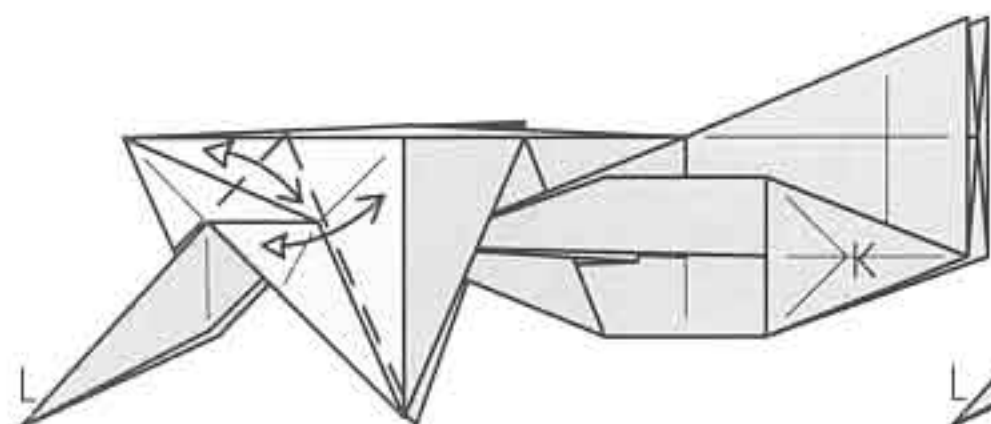

37 Fold and unfold through all layers.

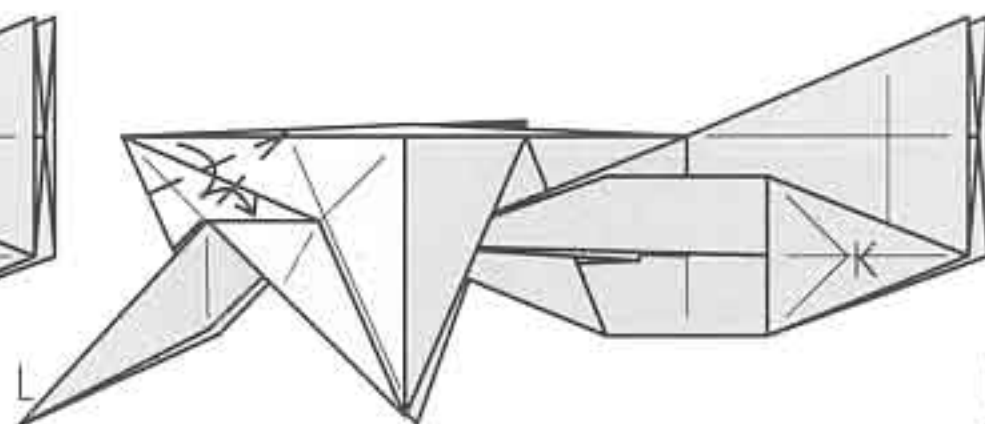

38 Fold the thick point over and over.

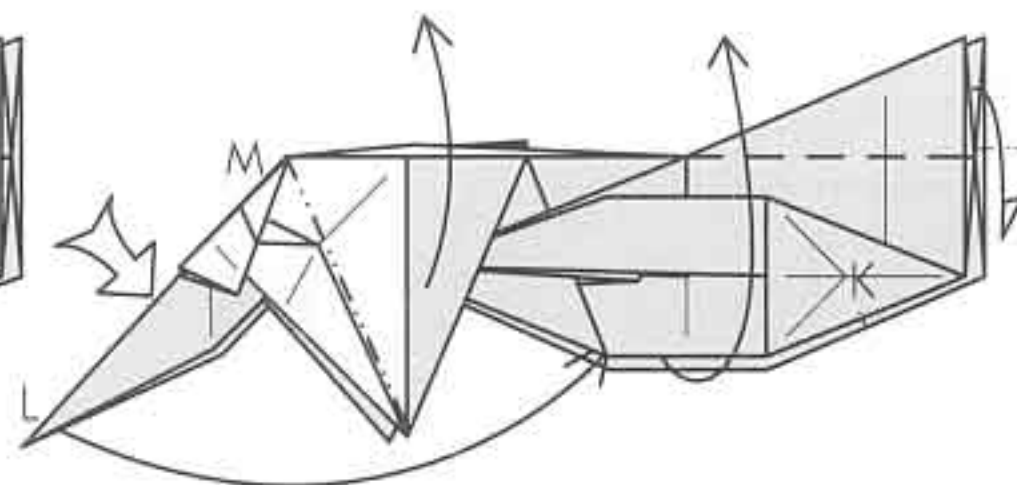

39 Squash-fold flap L as you open the model out flat. The mountain folds run to point M.

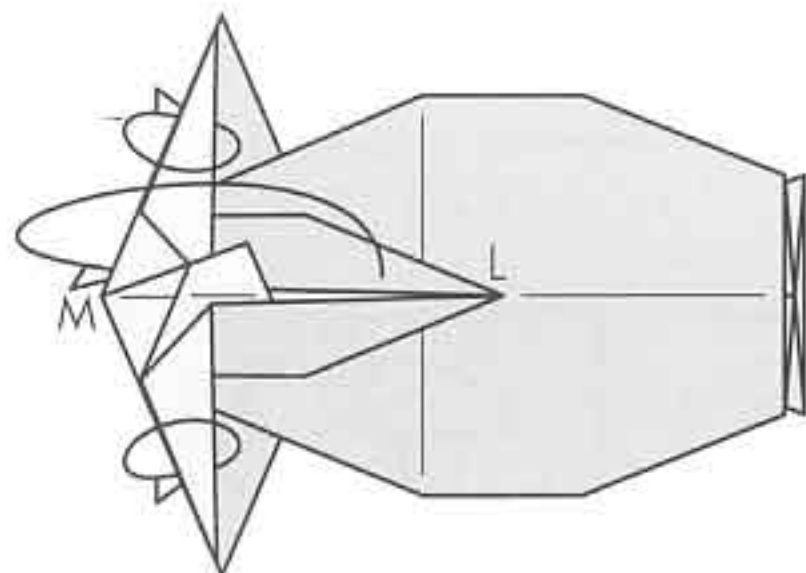

40 Turn corner M inside-out and fold point L to the rear.

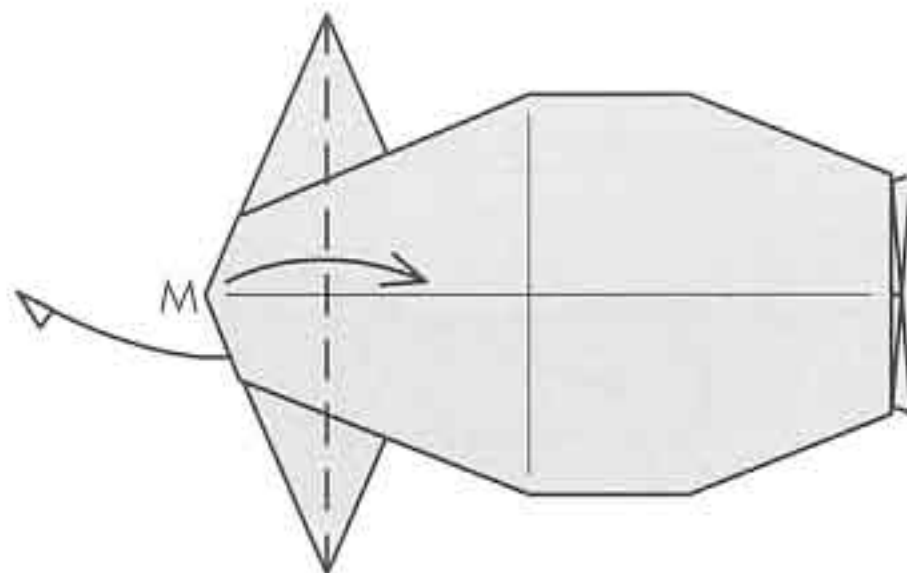

41 Fold corner M to the right and allow flap L to swing out from behind.

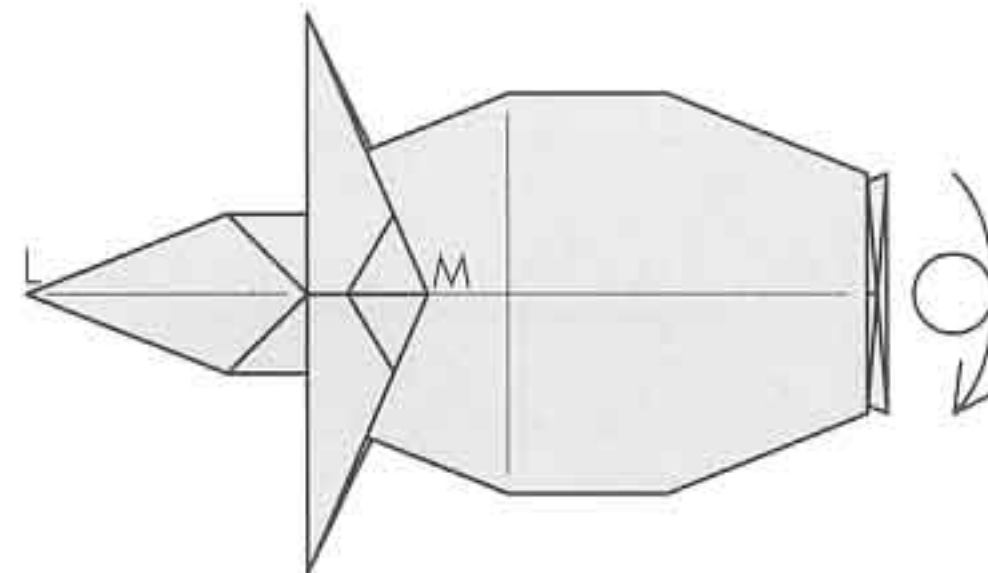

42 Turn the model over from top to bottom.

lion

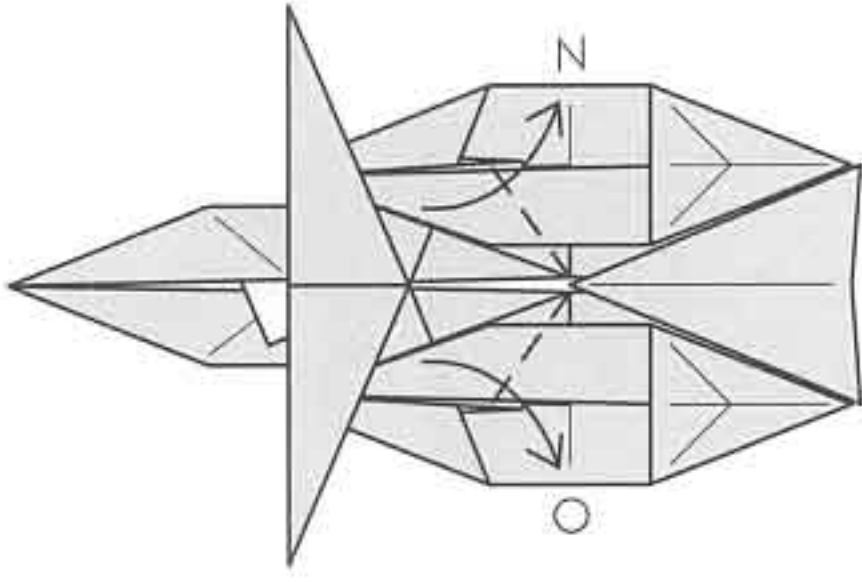

43 Untuck the two flaps trapped in the legs and fold them to align with line NO. A gusset forms along the left side of each flap.

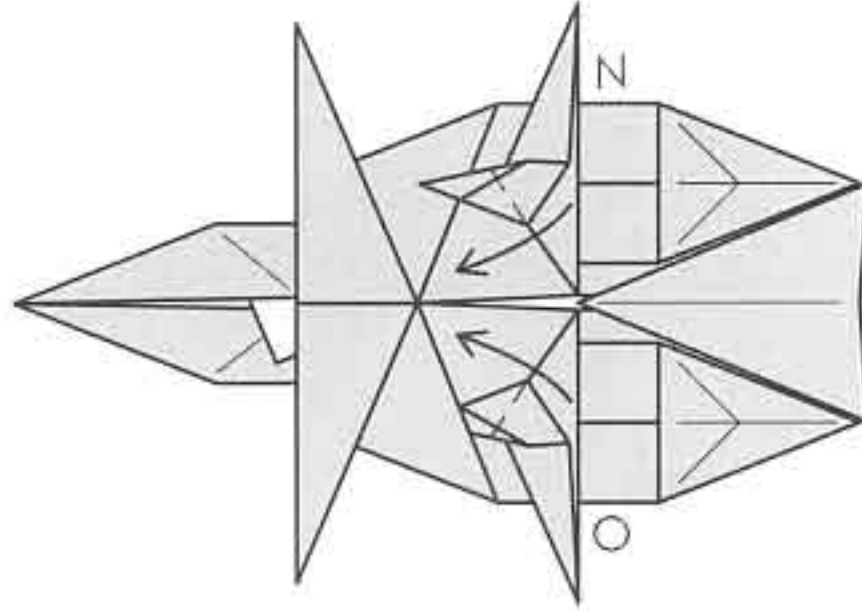

44 Fold the two points back to the left, leaving the gussets in place.

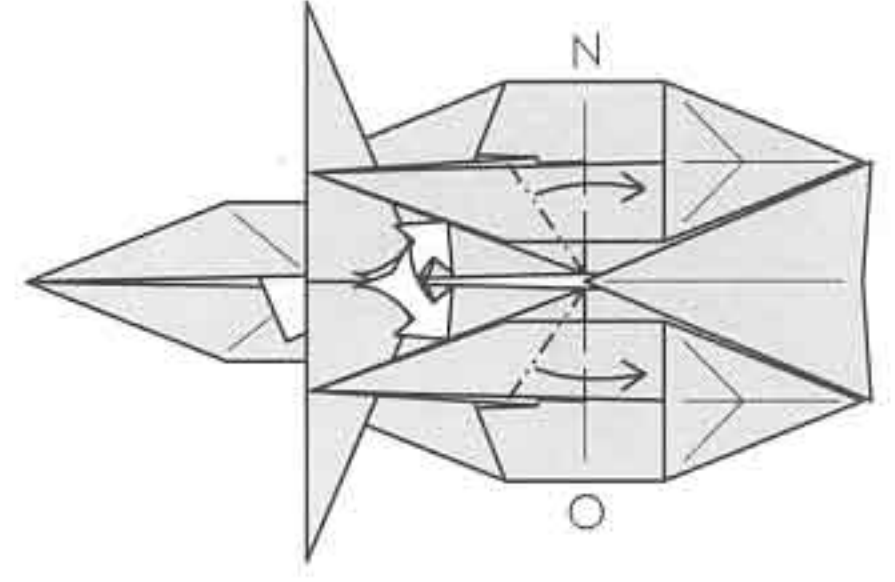

45 Squash-fold the two points on existing creases.

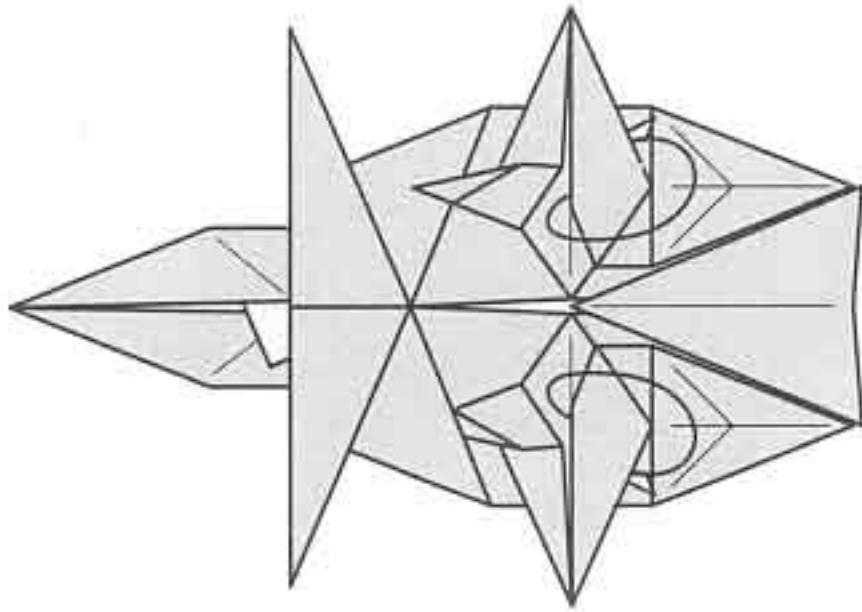

46 Fold one layer from front to back on each point.

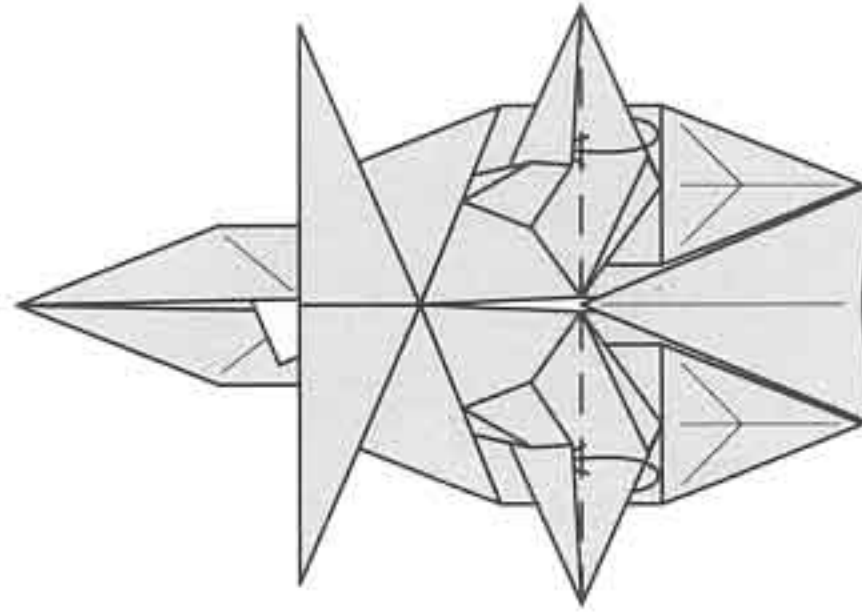

47 Tuck half of each point into the pocket.

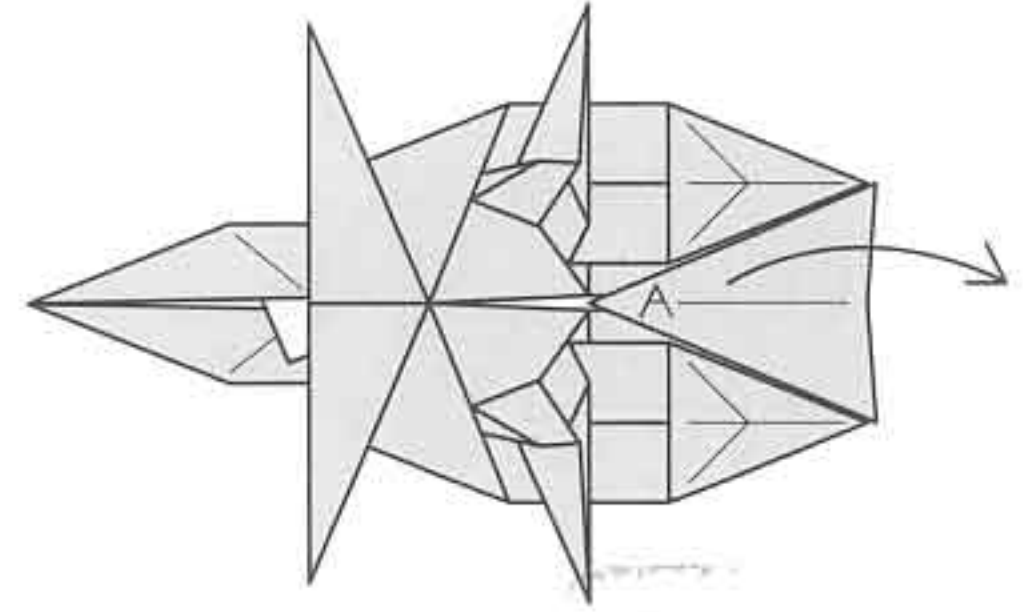

48 Fold point A to the right.

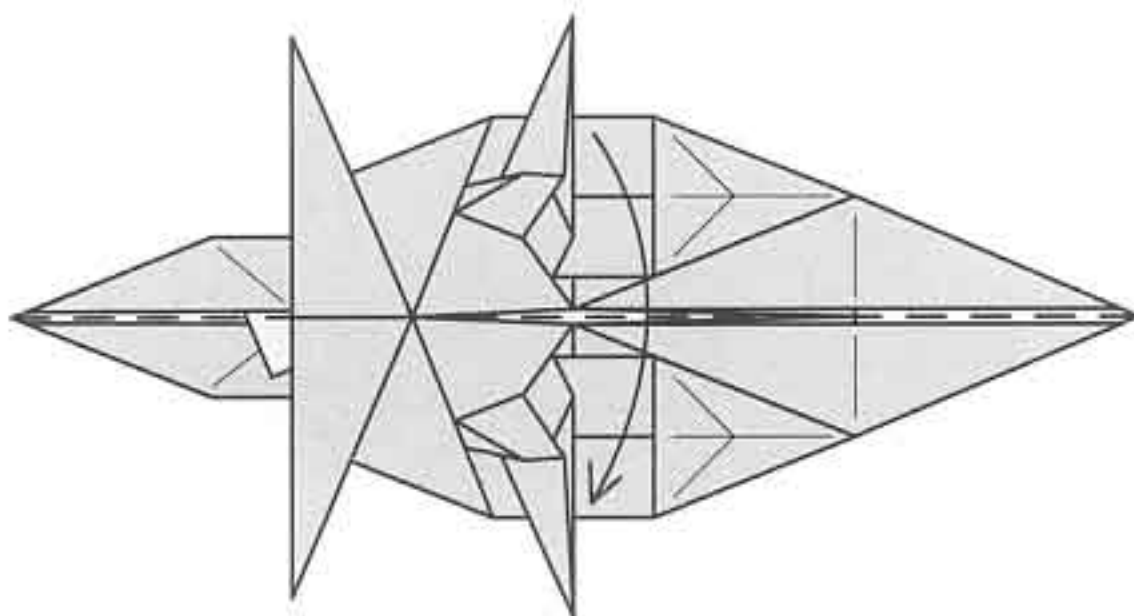

49 Fold the model in half.

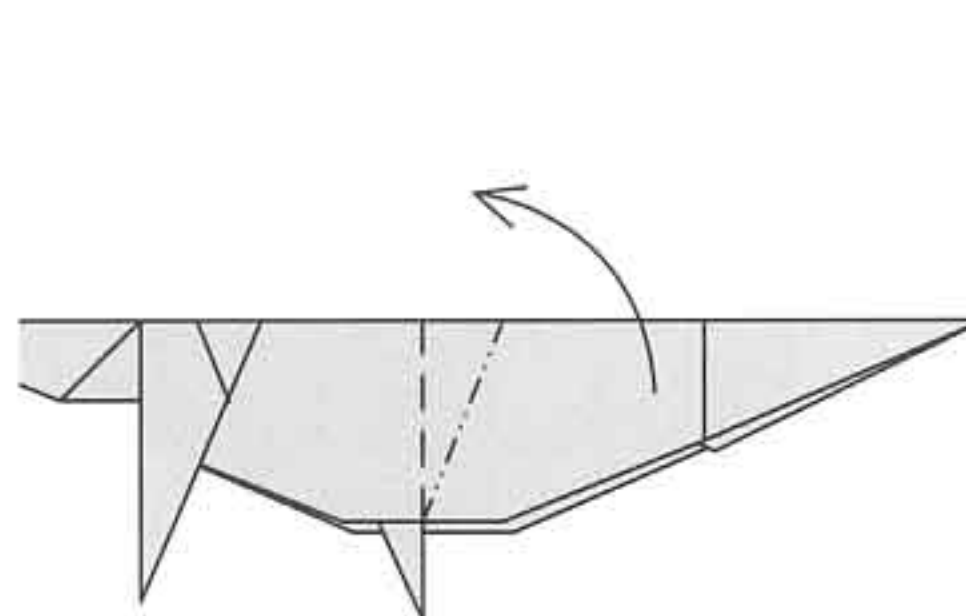

50 Crimp the right side of the model upward.

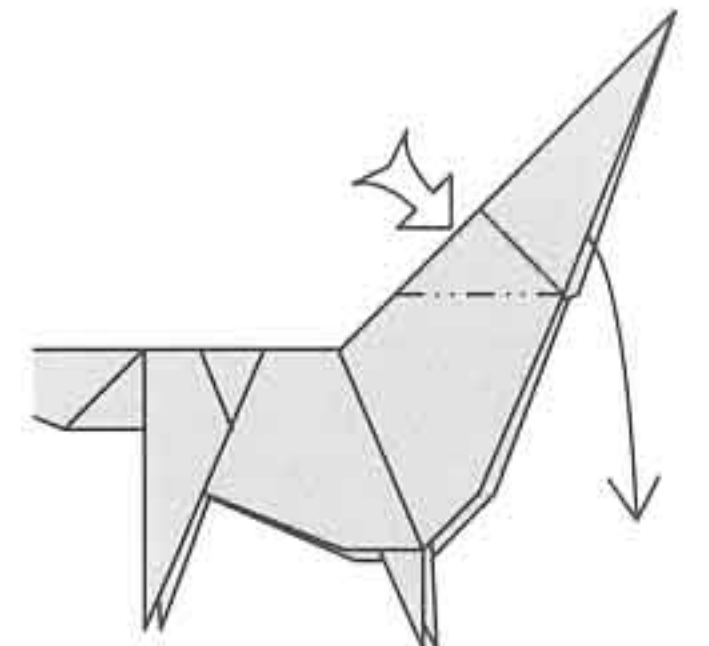

51 Reverse-fold the right side downward.

African savanna

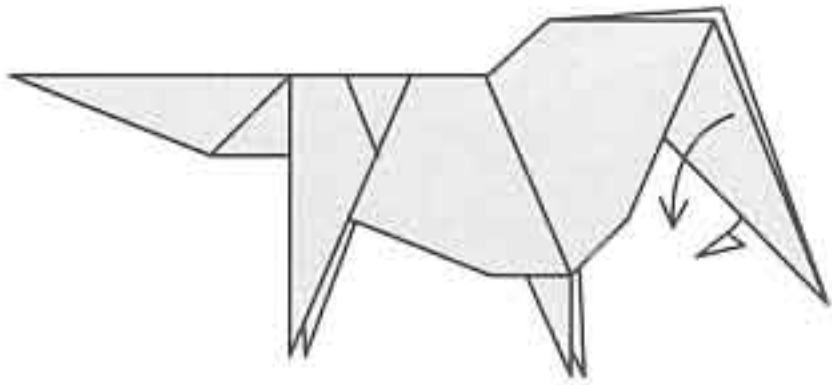

52 Fold down one layer of the head on each side.

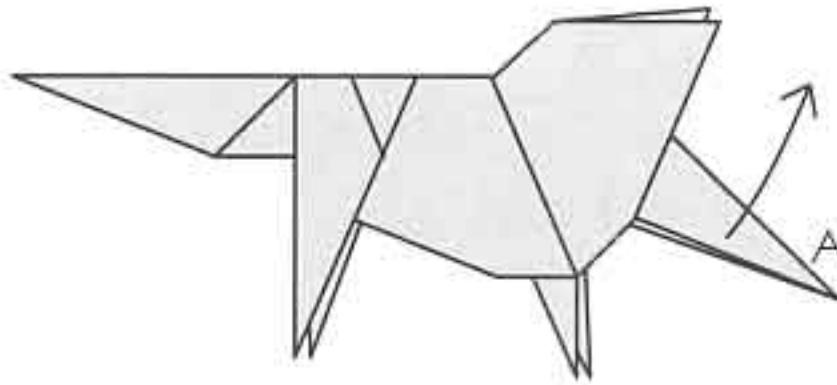

53 Slide point A upward.

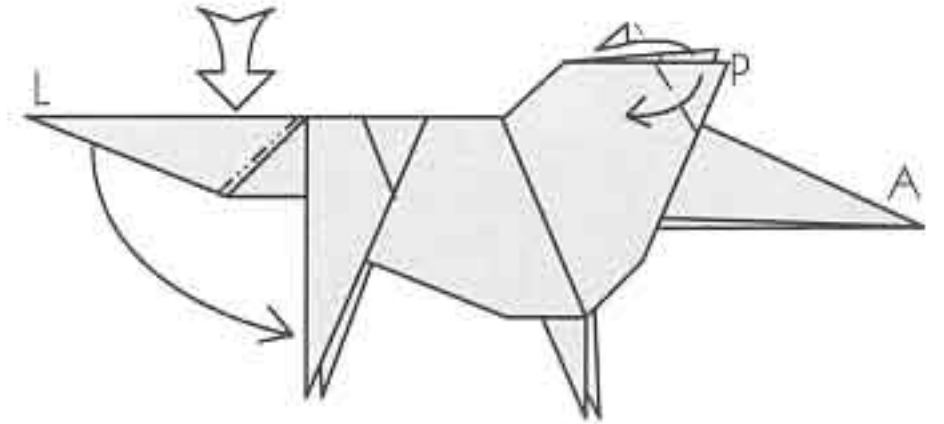

54 Reverse-fold point L downward. Valley-fold corner P down and to the left; repeat behind.

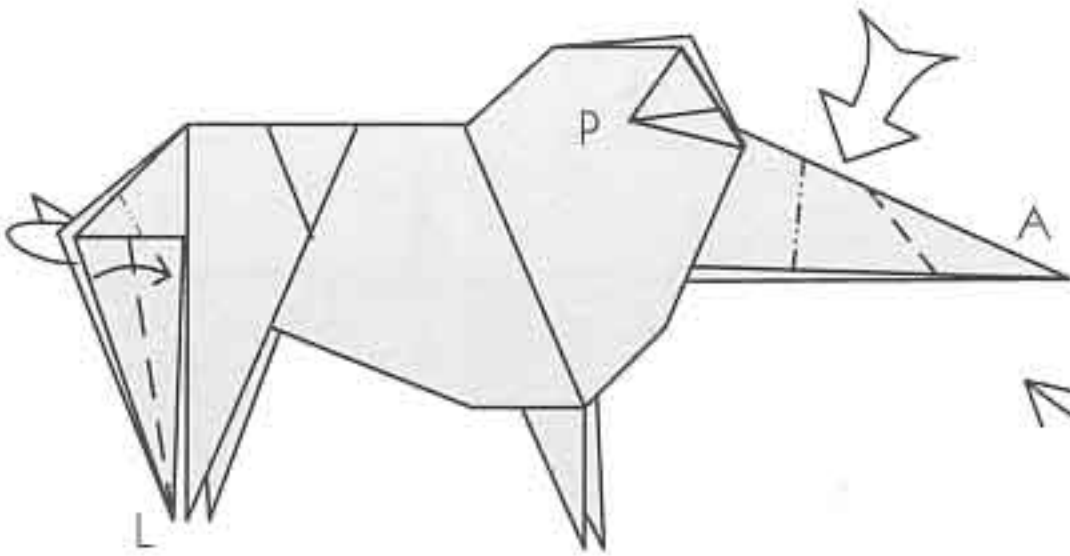

55 Narrow the tail (point L) with reverse folds. Reverse-fold the head (point A) twice.

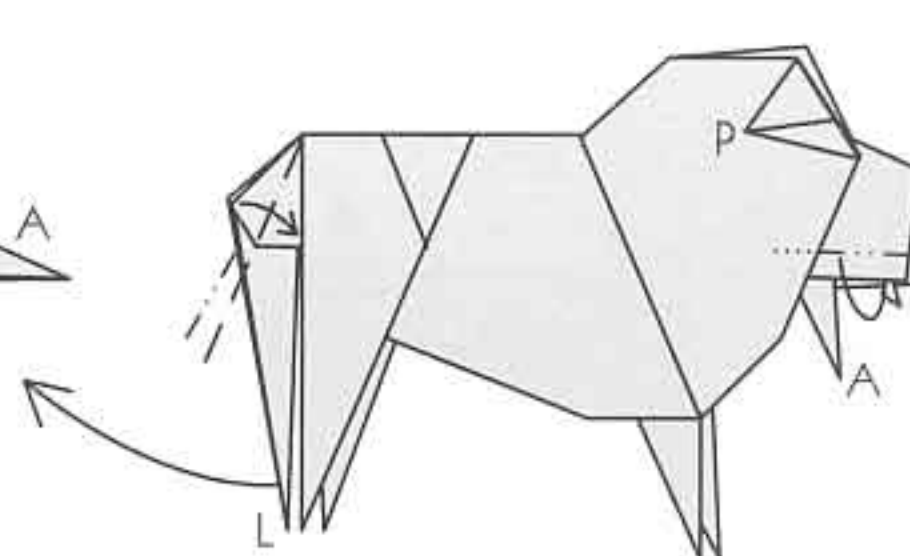

56 Wrap the top edges of the tail to the right and reverse-fold the rest of the tail to the left. Narrow the head with mountain folds.

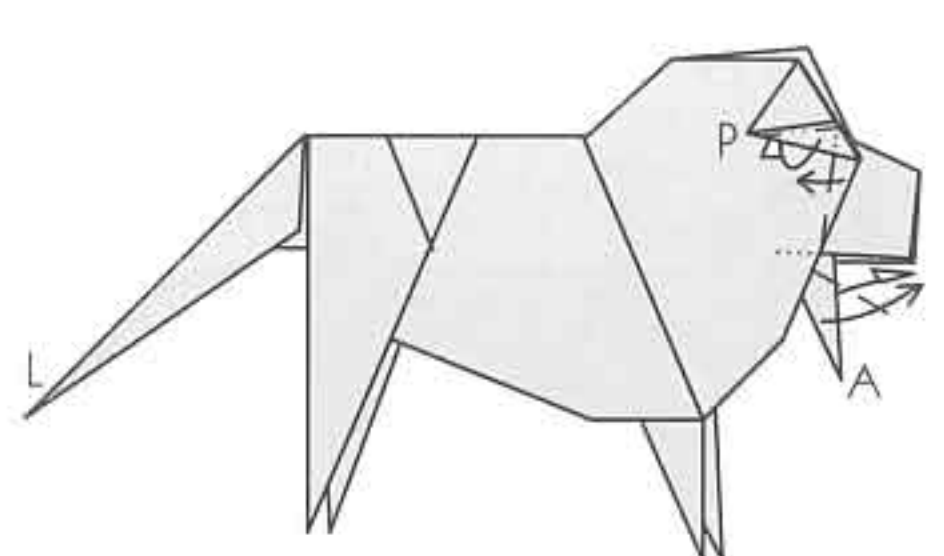

57 Fold the lower edge of point P (the ear) underneath. Outside reverse-fold point A (the jaw).

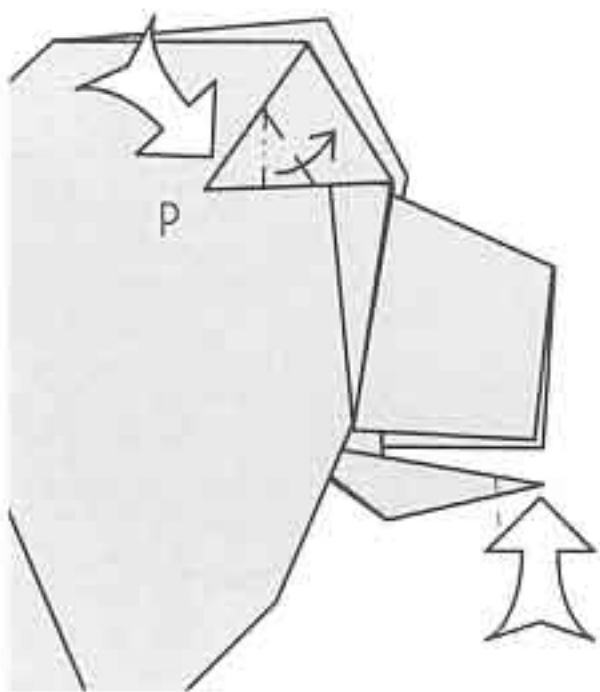

58 Squash-fold the ear. Repeat behind. Reverse-fold the tip of the lower jaw.

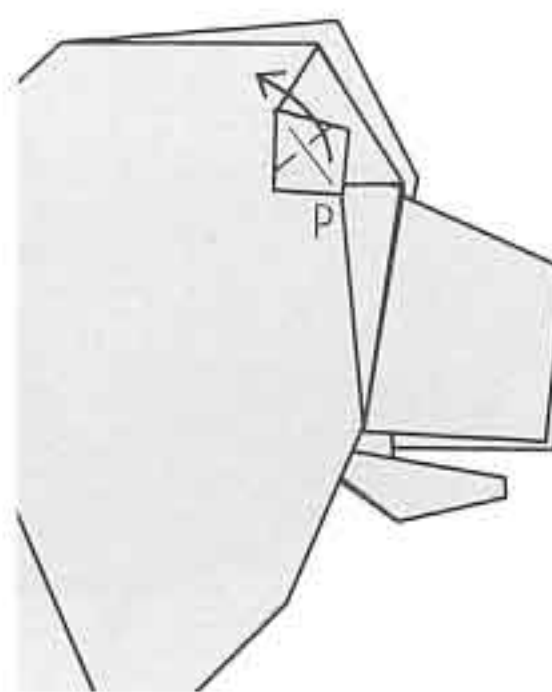

59 Petal-fold the ear. Repeat behind.

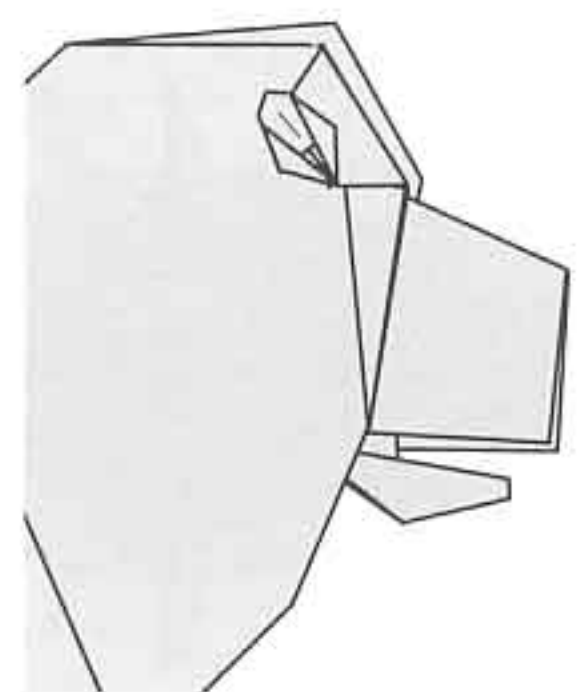

60 Finished ear.

lion

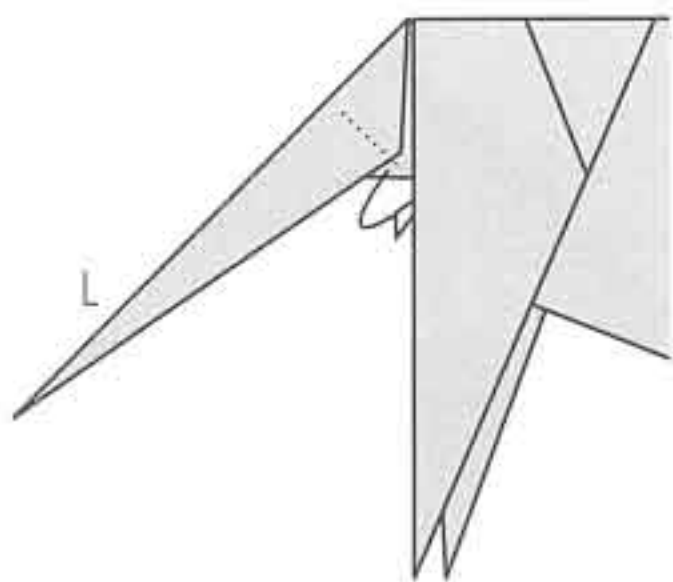

61 Mountain-fold the triangular flap inside the base of the tail. Repeat behind.

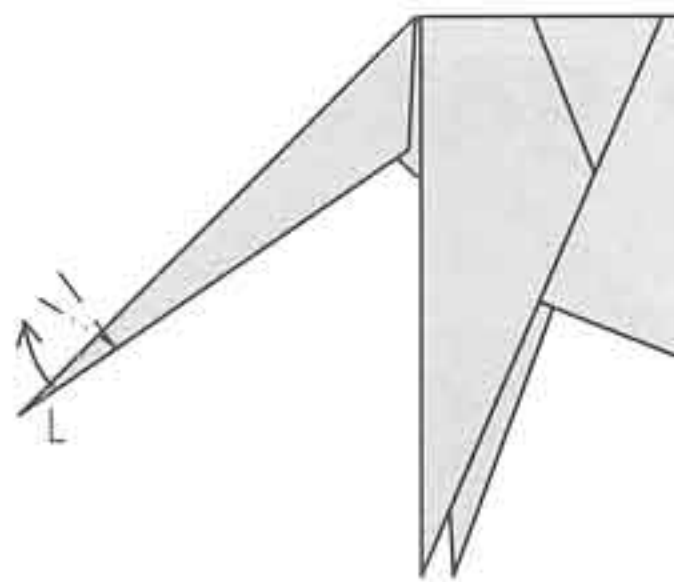

62 Crimp the tip of the tail.

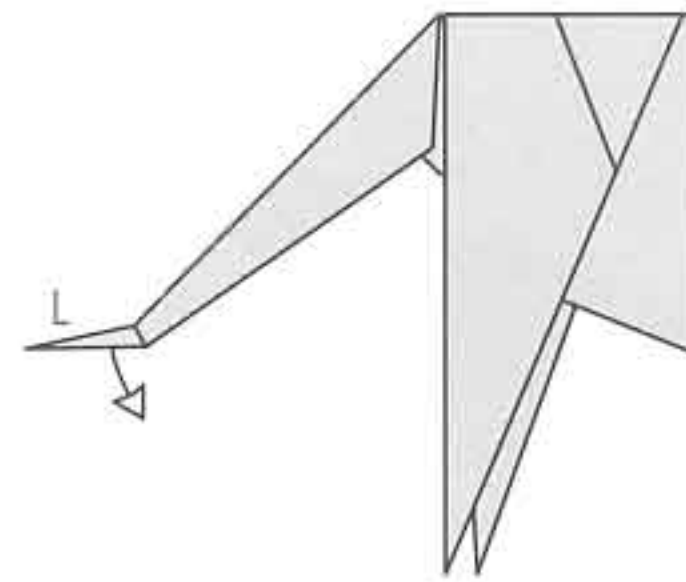

63 Pull out some loose paper from the tip of the tail.

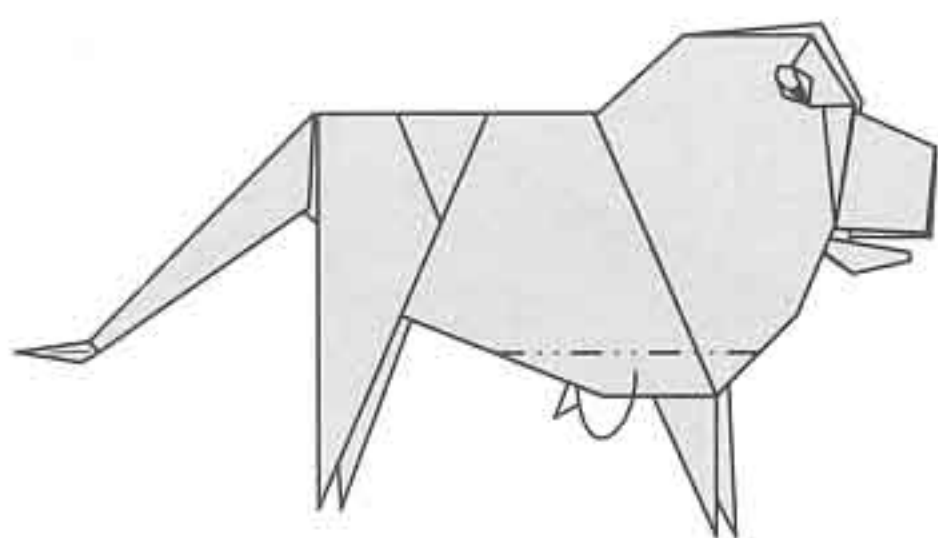

64 Mountain-fold the chest underneath. Repeat behind.

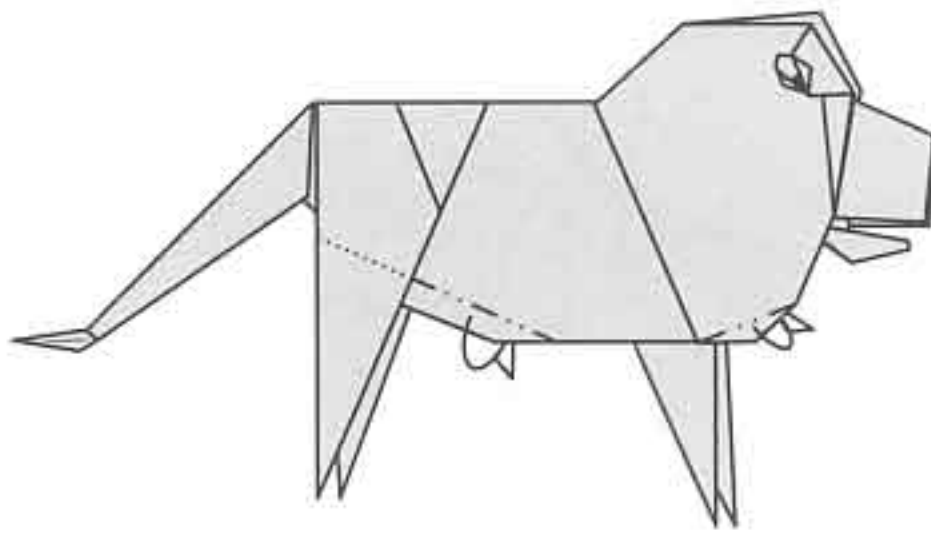

65 Mountain-fold the belly and the base of the mane. Repeat behind.

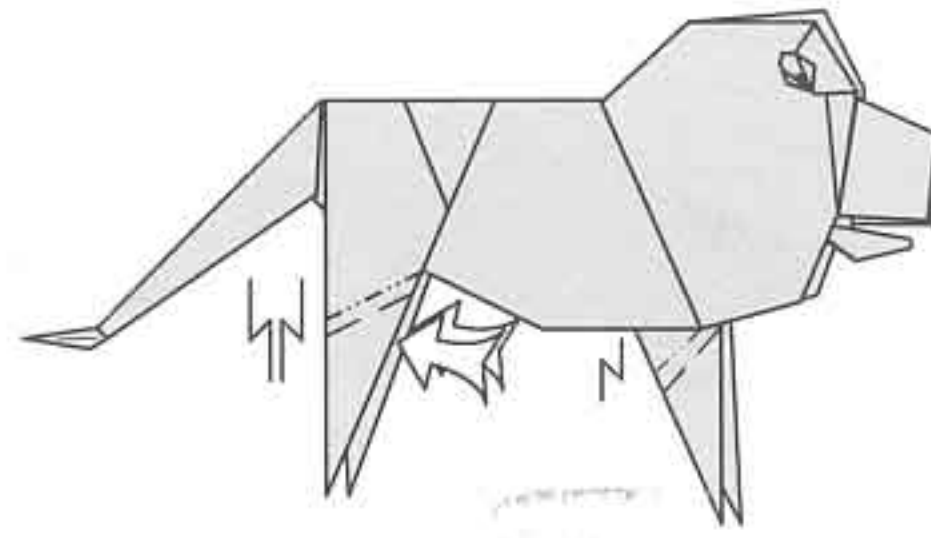

66 Crimp the hind legs. Pleat the forelegs.

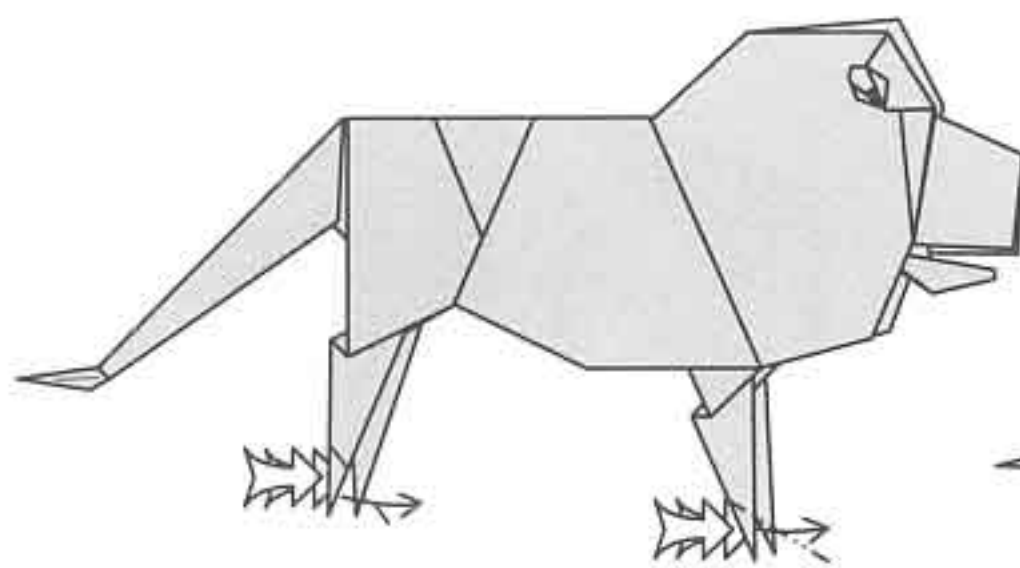

67 Squash-fold the feet.

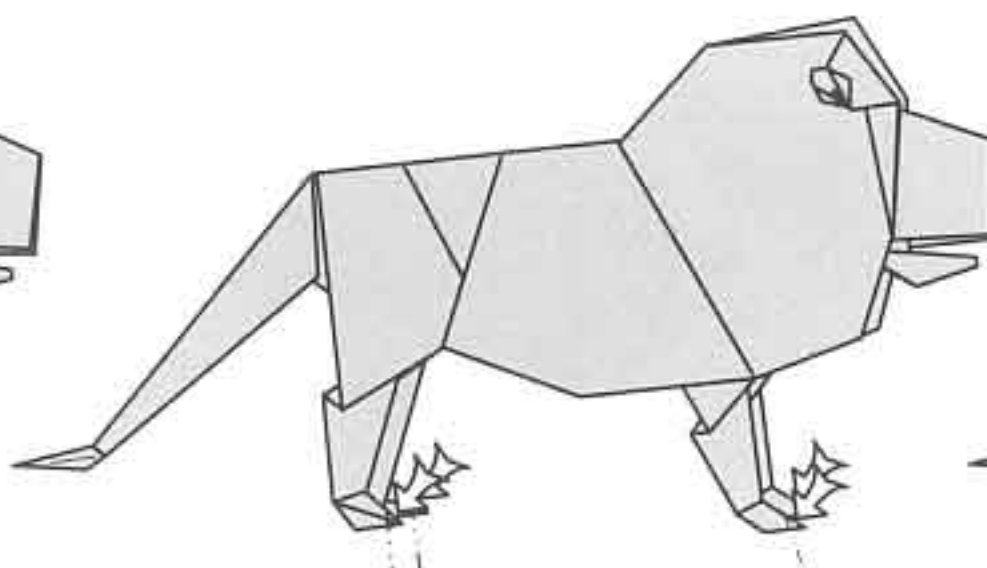

68 Blunt the feet with reverse folds.

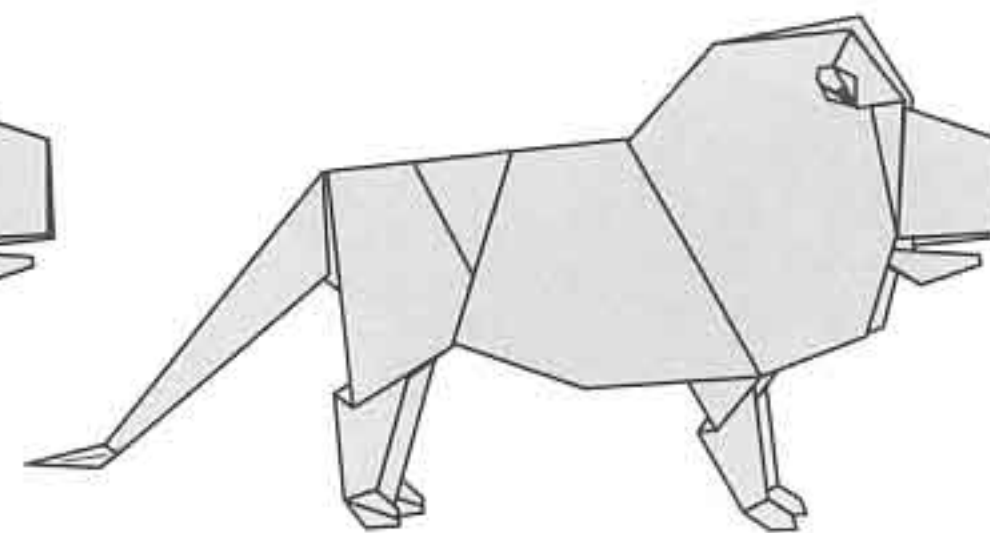

Finished Lion.

◆ gazelle ◆

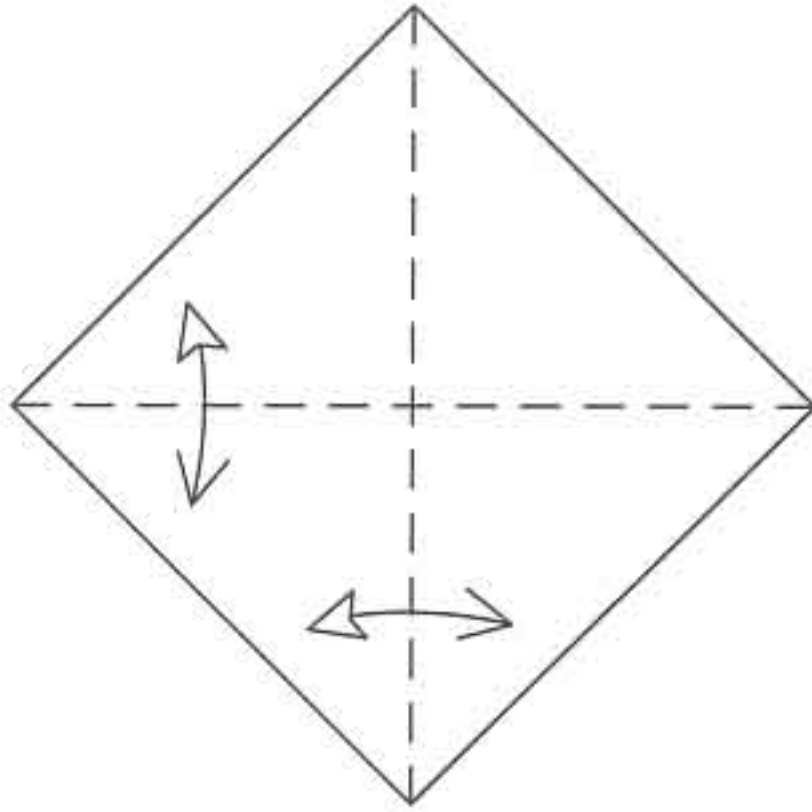
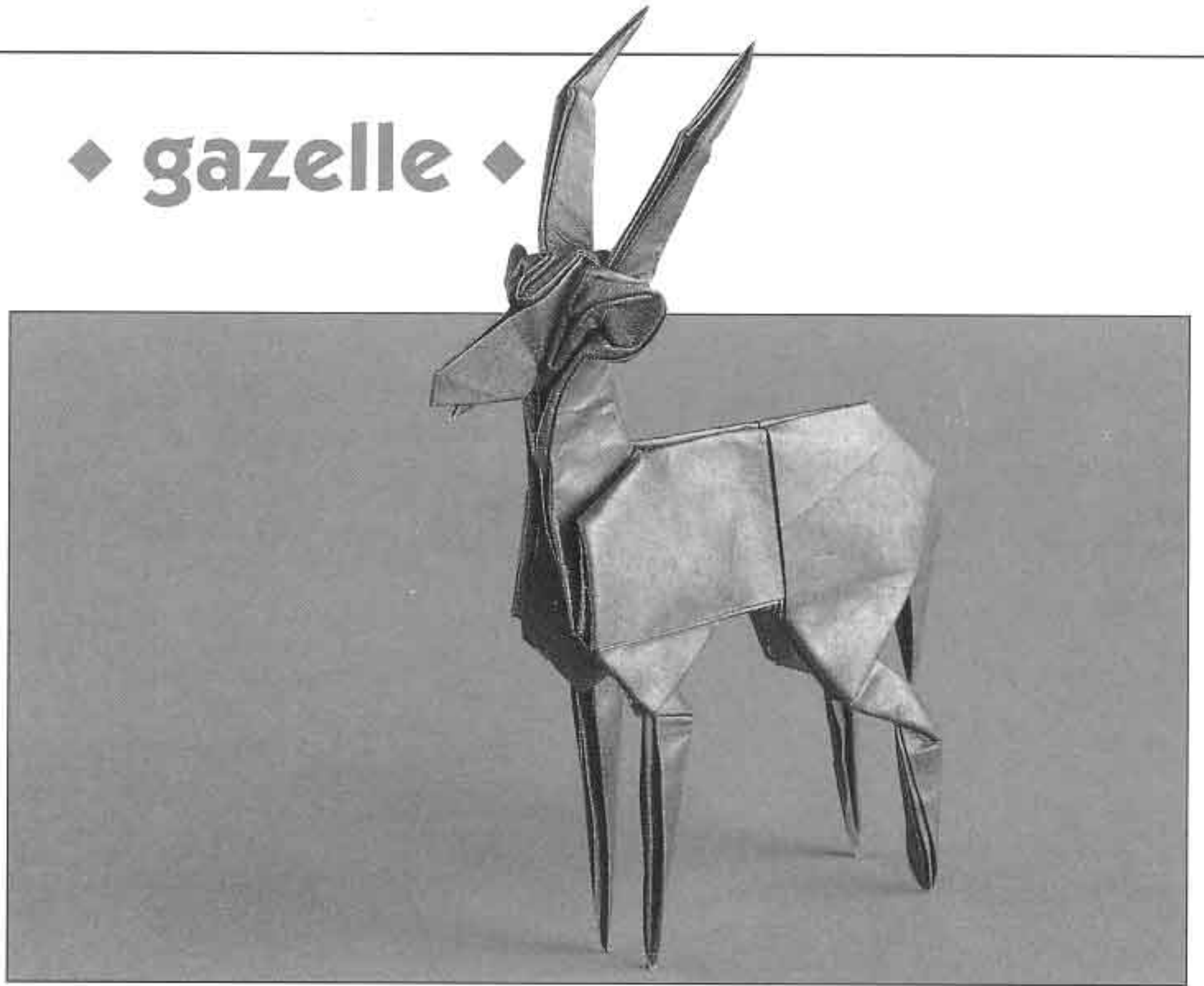

1 Begin with the white side up. Fold and unfold.

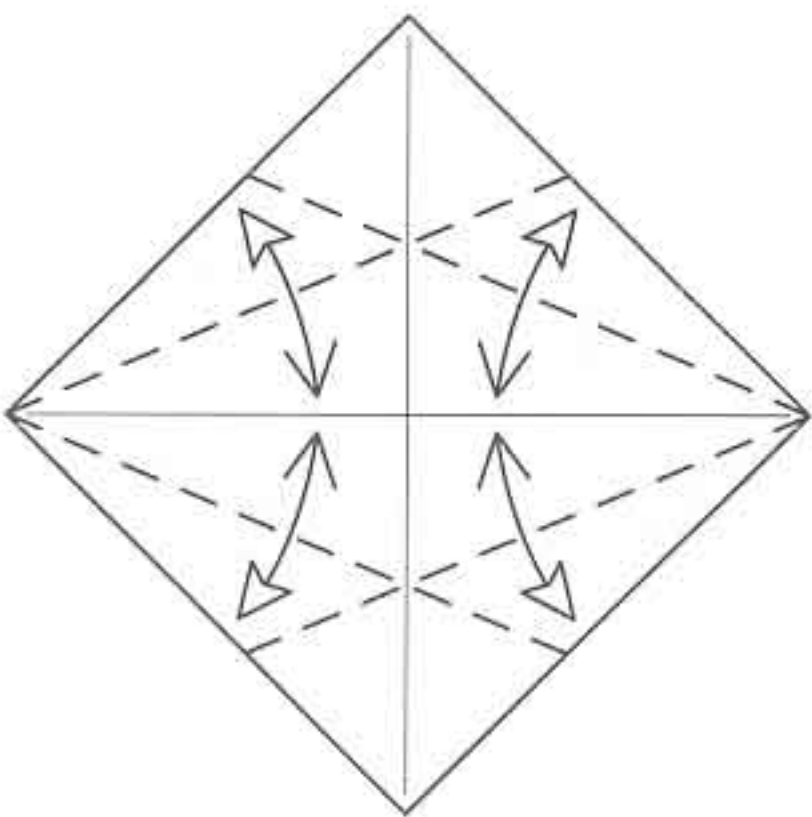

2 Crease the angle bisectors.

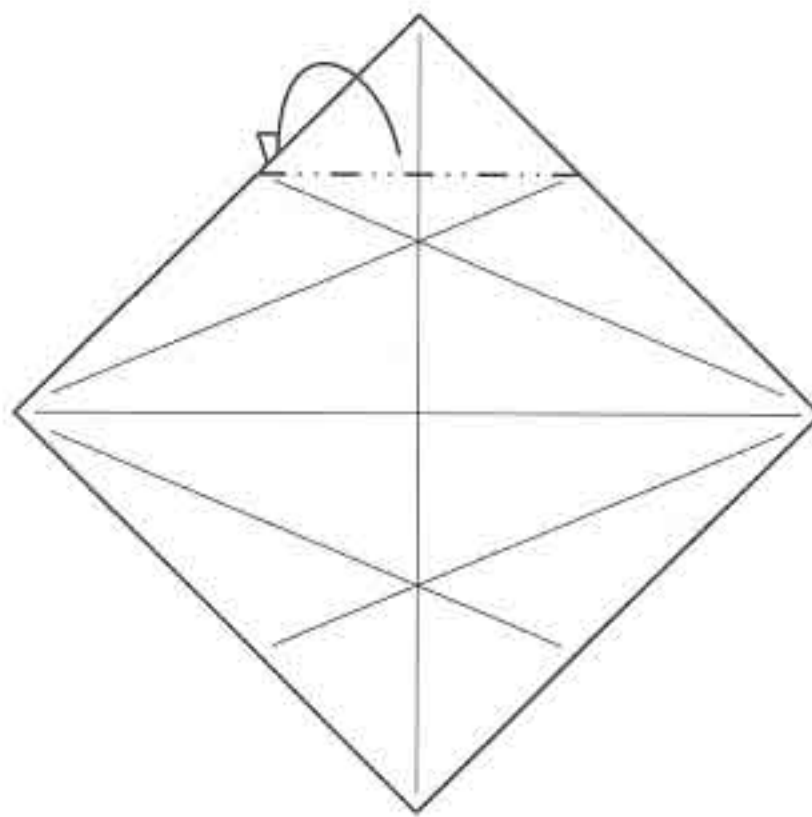

3 Mountain-fold the point behind.

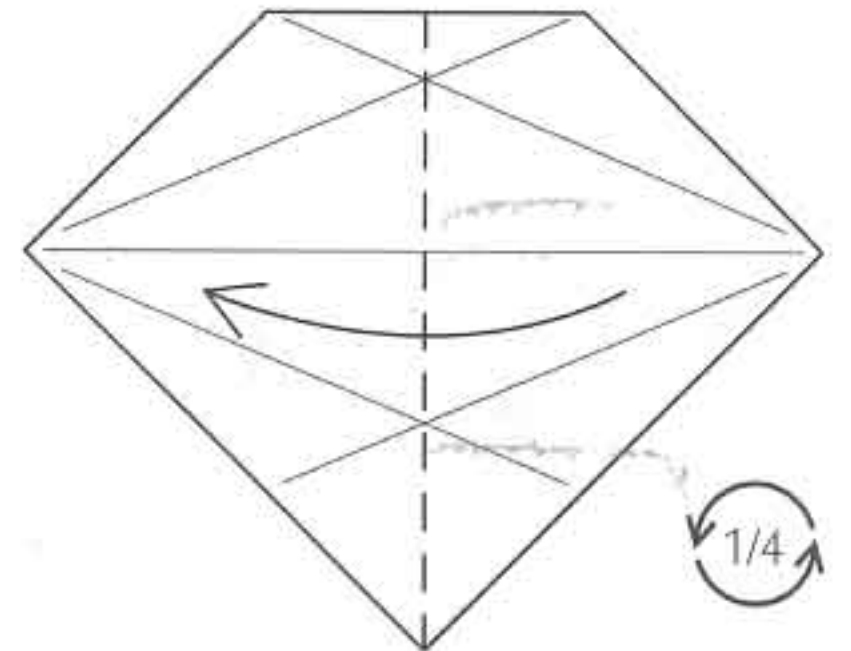

4 Fold the model in half and rotate 1/4 turn counterclockwise.

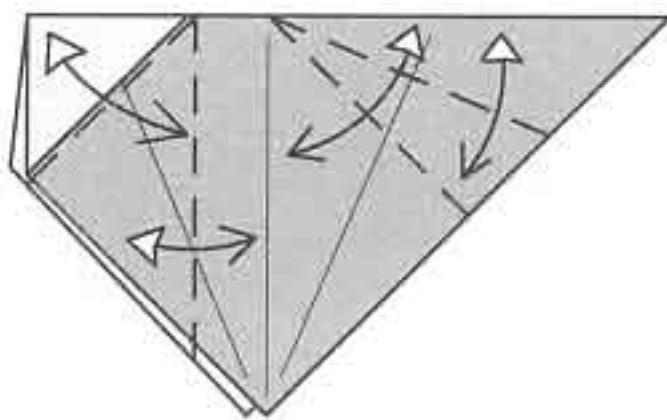

5 Fold and unfold.

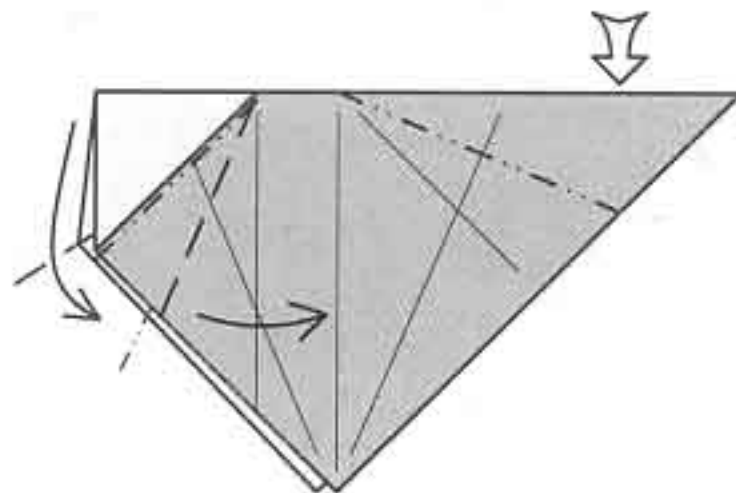

6 Crimp the left side downward. Reverse-fold the right point on existing creases.

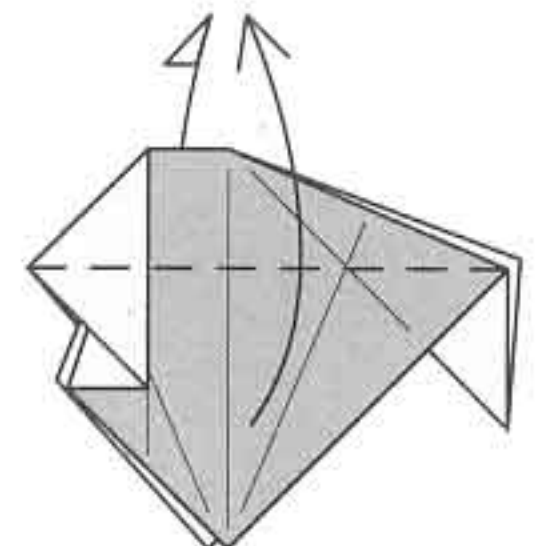

7 Fold the paper upward in front and behind.

gazelle

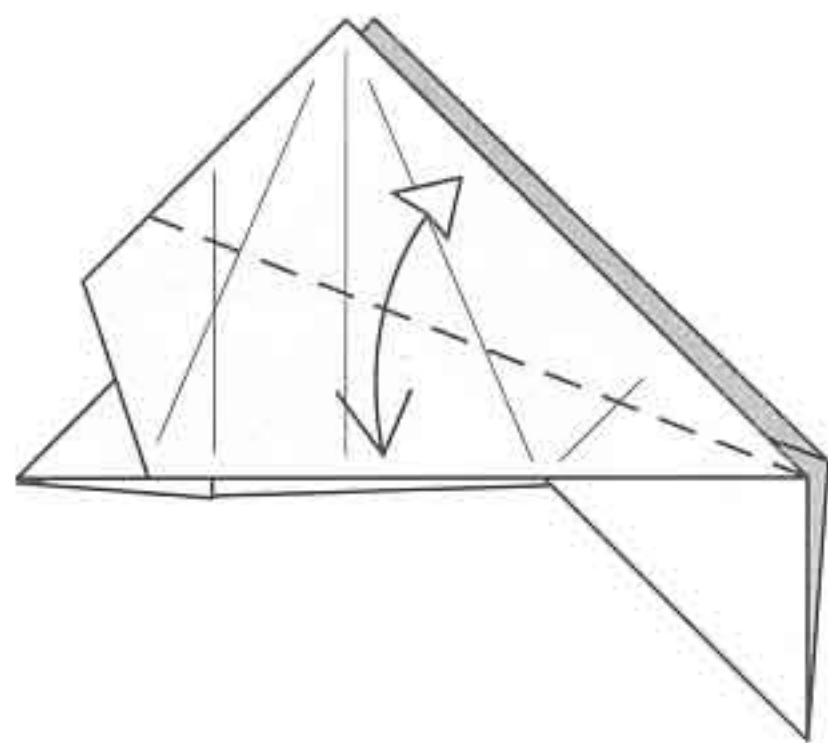

8 Fold and unfold. Repeat behind.

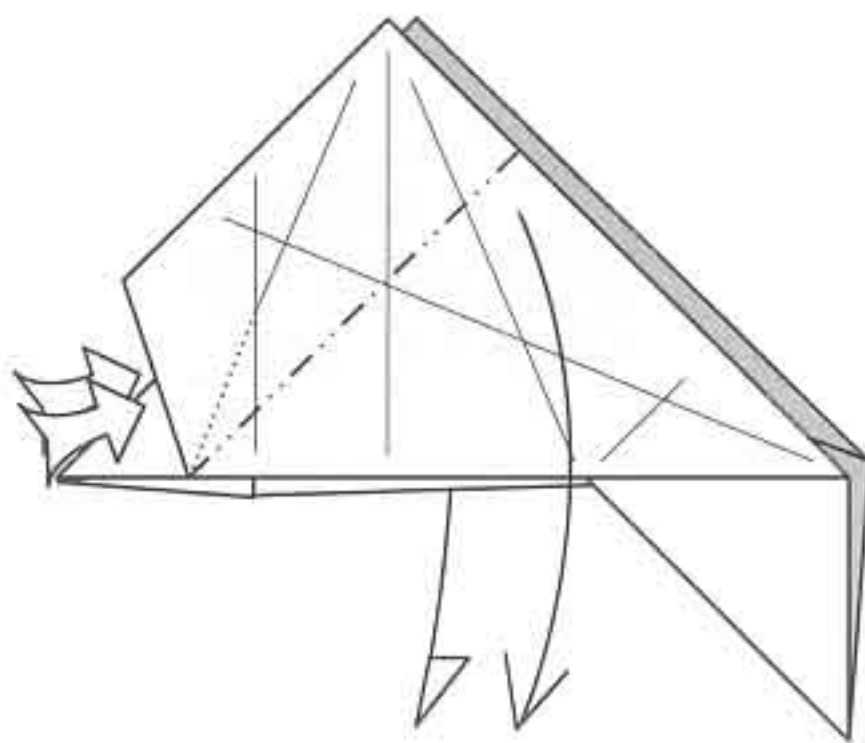

9 Squash-fold the edges. The long mountain folds run parallel to the raw edges.

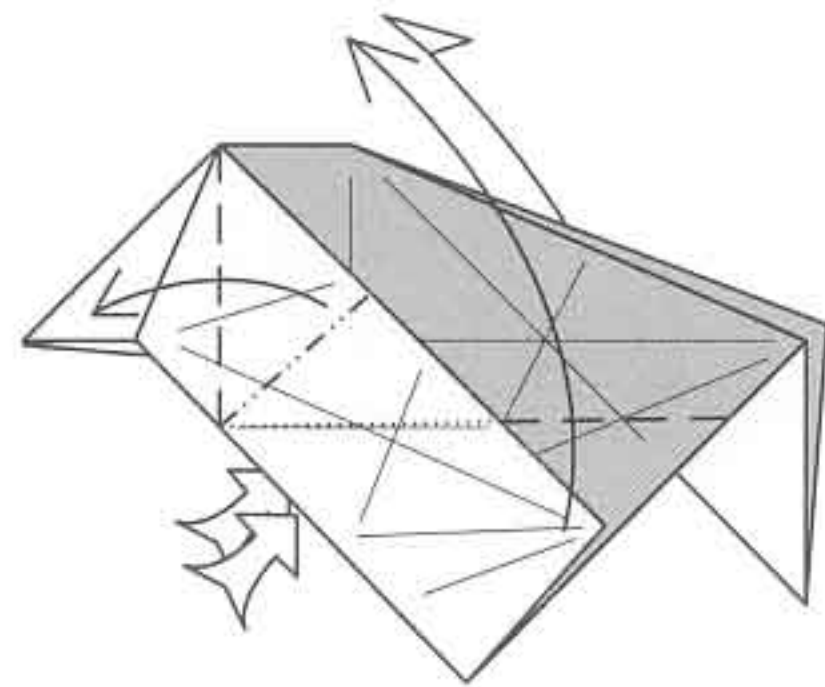

10 Squash-fold the edges upward.

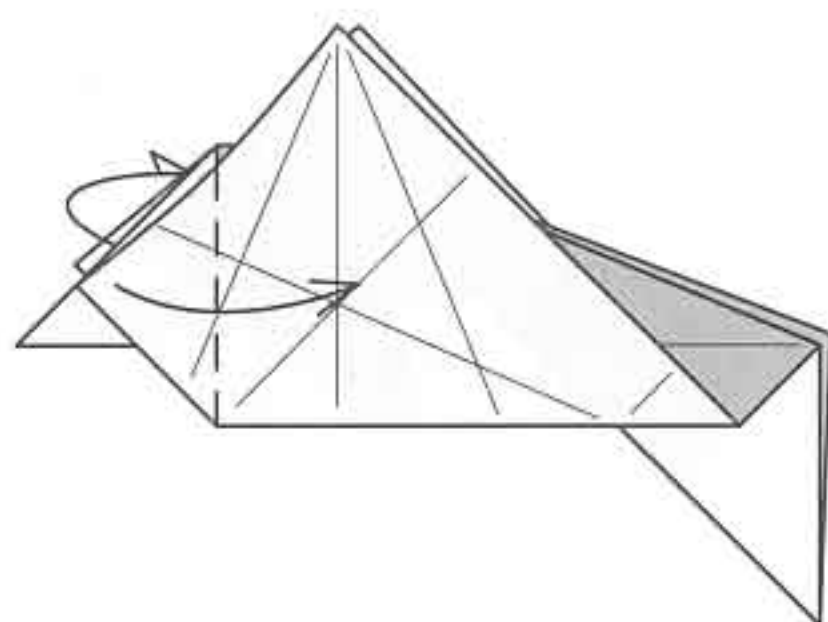

11 Fold one flap to the right in front and behind.

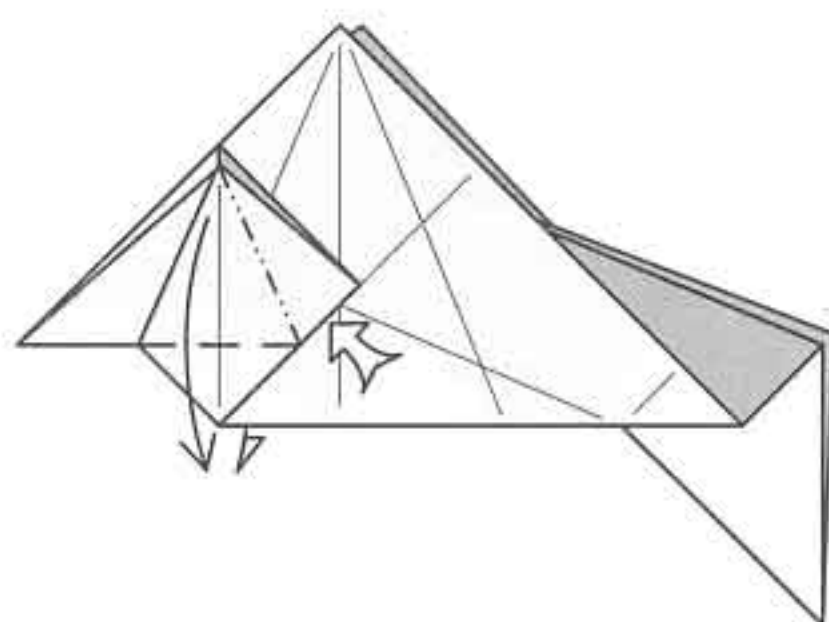

12 Petal-fold. Repeat behind.

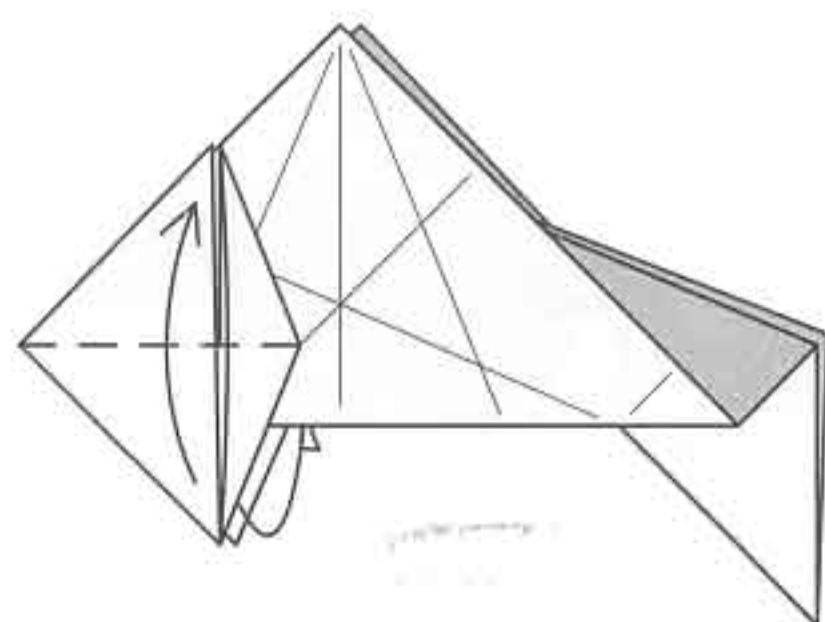

13 Fold the flap back up. Repeat behind.

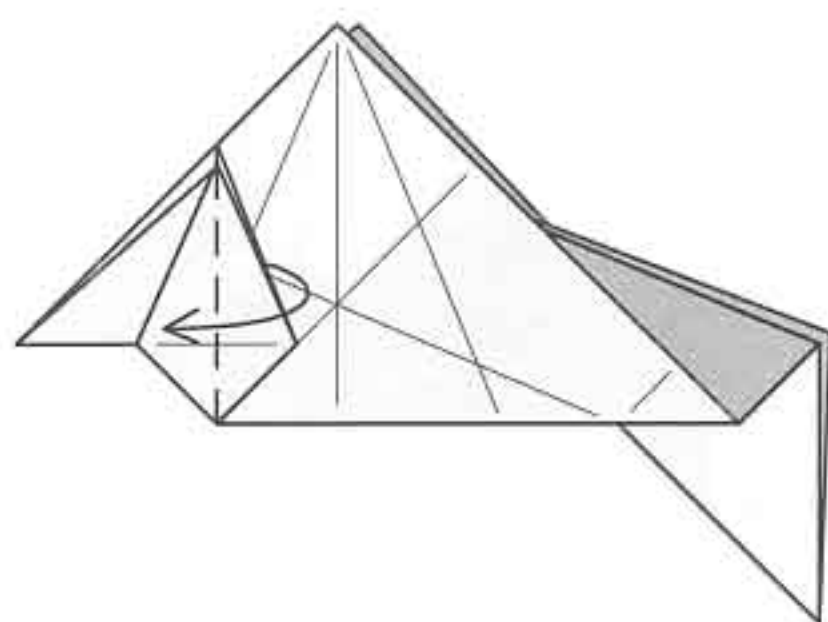

14 Fold one flap to the left. Repeat behind.

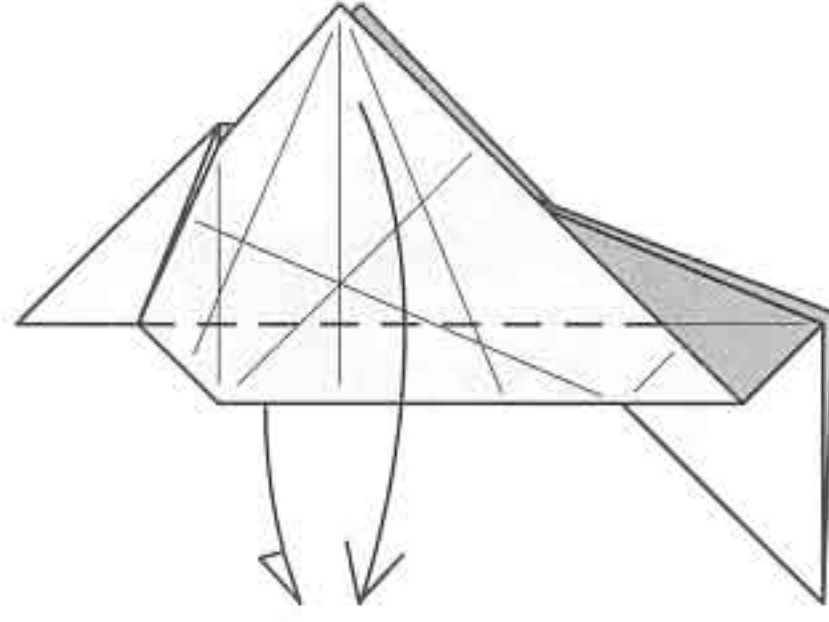

15 Fold down one layer. Repeat behind.

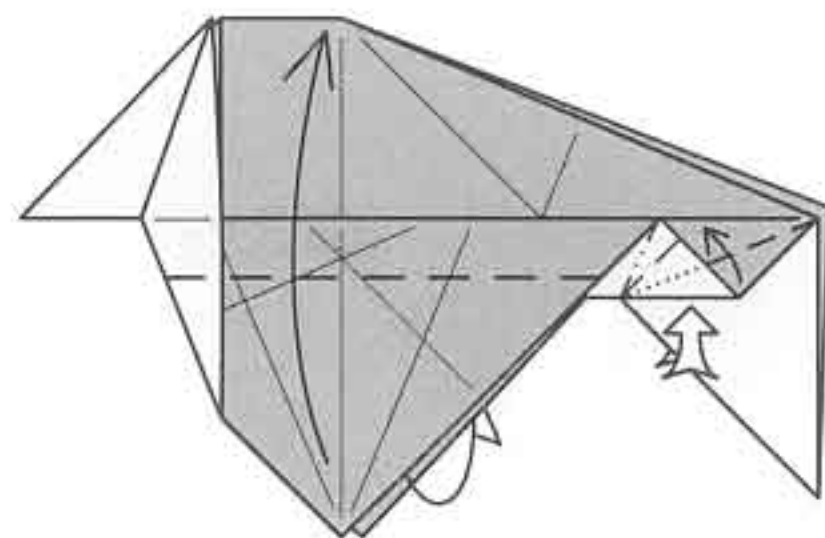

16 Fold the point up to the top edge. Reverse-fold the edge at the right. Repeat behind.

African savanna

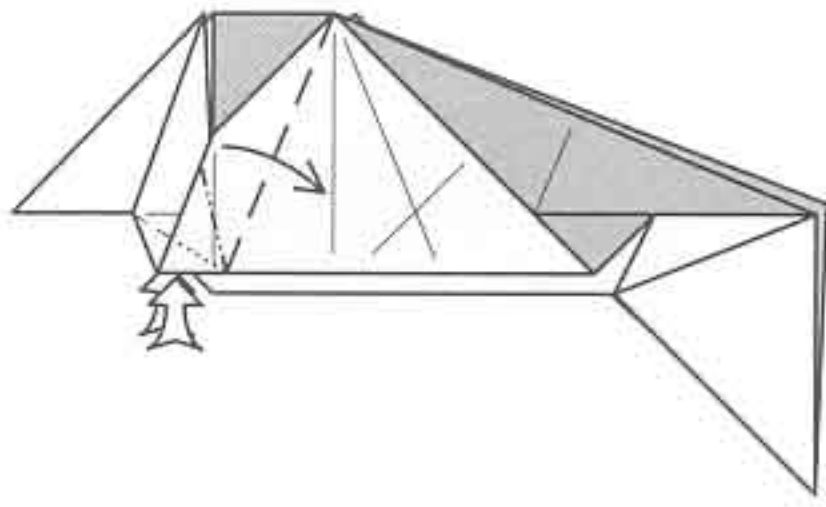

17 Squash-fold. Repeat behind.

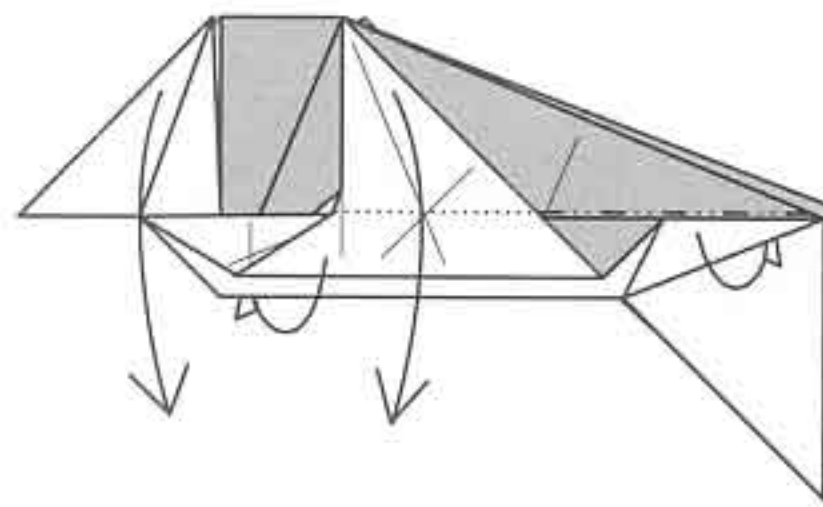

18 Swing two flaps down in front and tuck the narrow white edge up inside the model. Repeat behind.

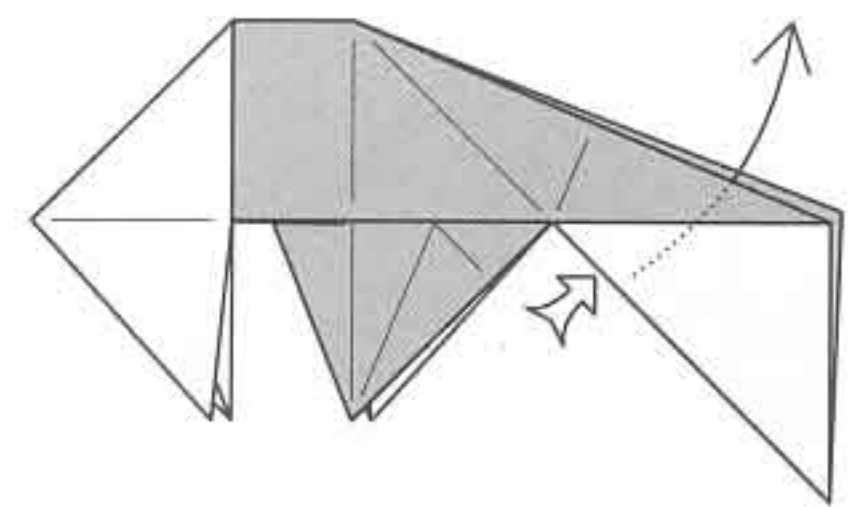

19 Undo the reverse fold.

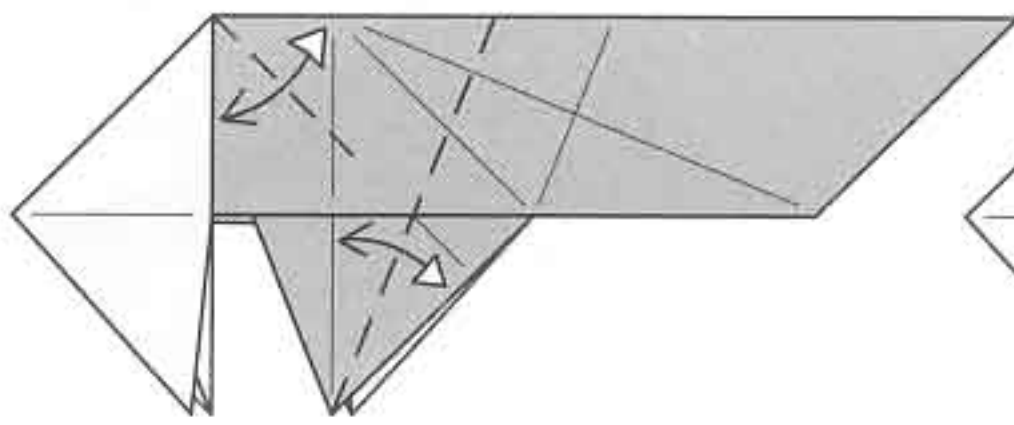

20 Fold and unfold.

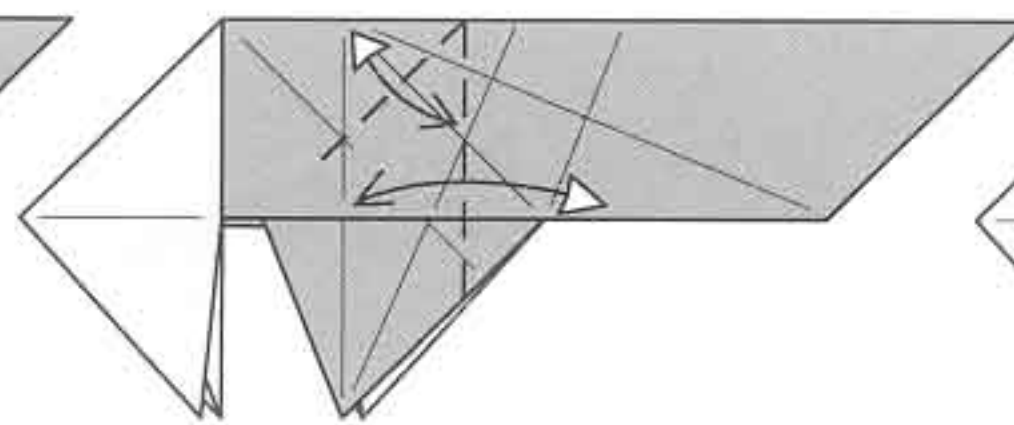

21 Fold and unfold.

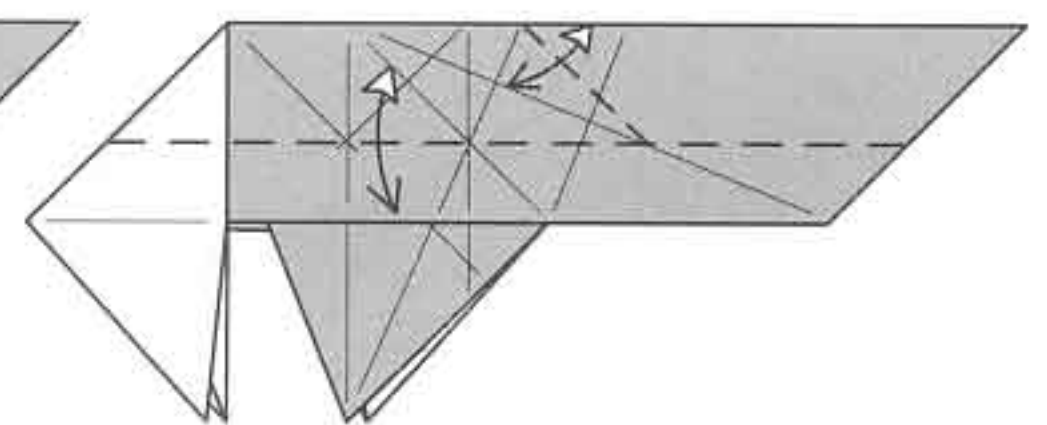

22 Fold and unfold.

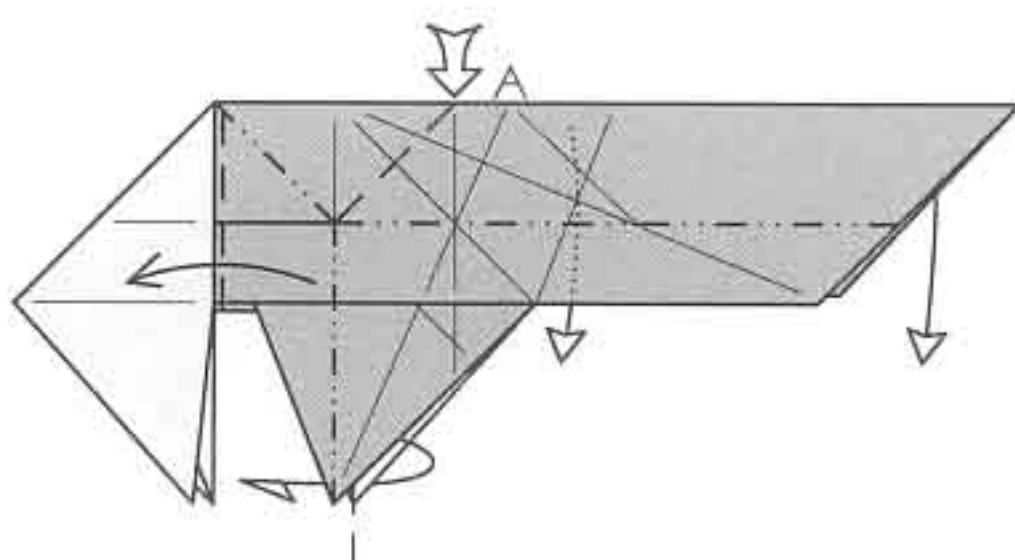

23 Crimp the right part of the model over to the left as you invert the top edge. Note where point A lands in the next step.

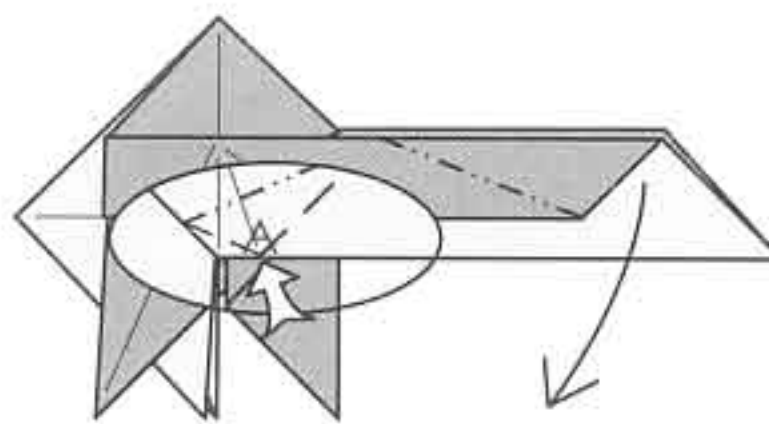

24 Crimp model internally and shift the right point downward.

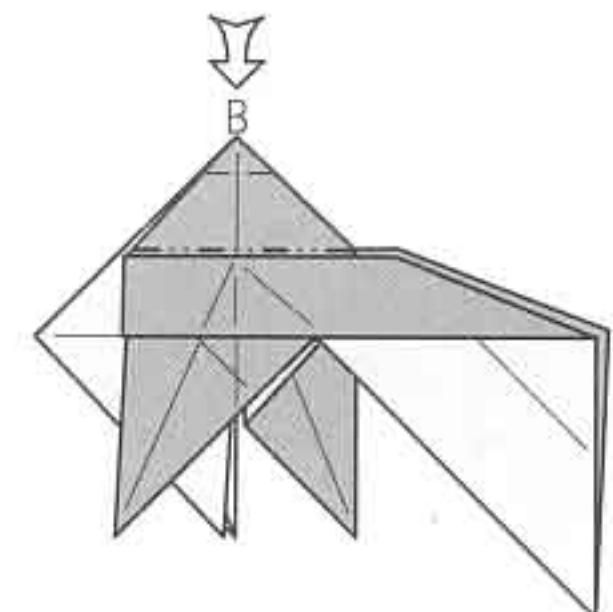

25 Closed-sink the triangular region (which makes a pyramid). Note the position of point B in the next step.

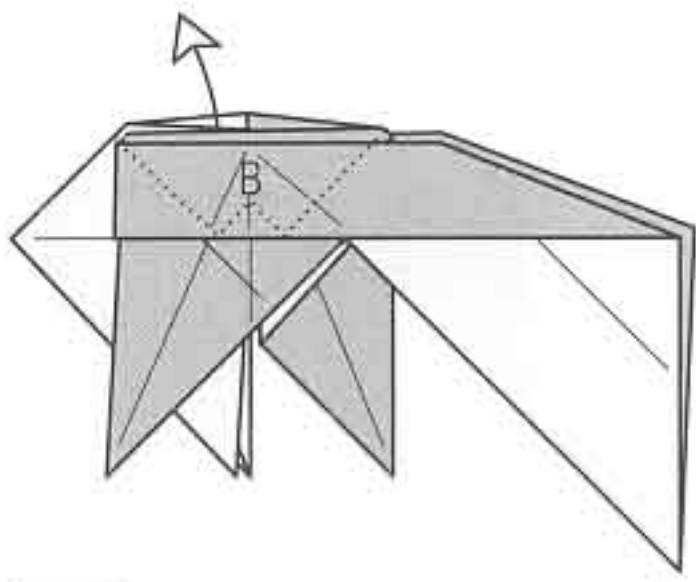

26 Pull out the white flap.

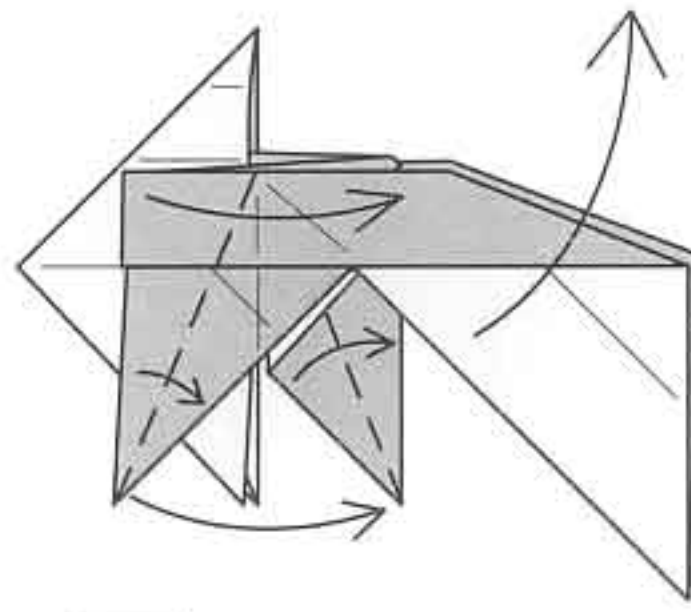

27 Fold one flap over and swing the right point upward.

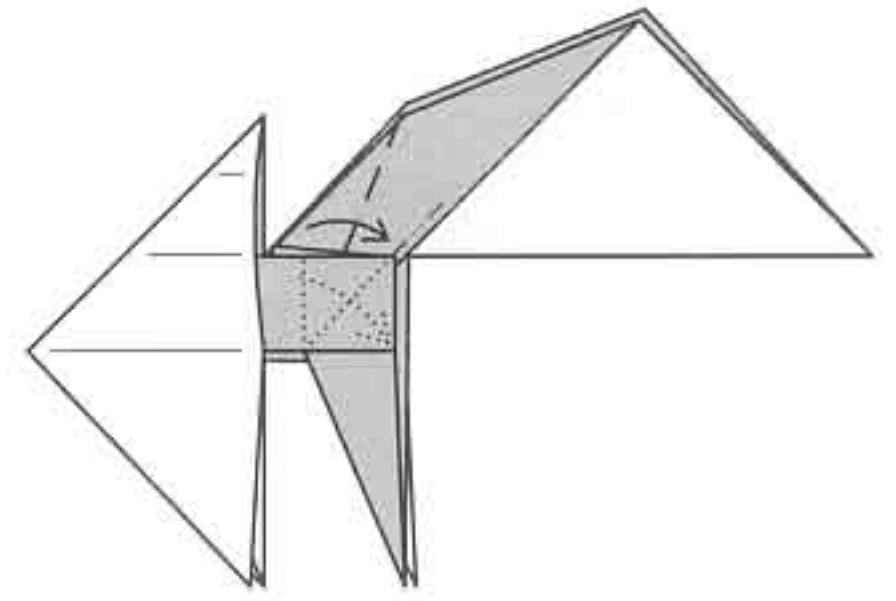

28 Reverse-fold the edge as far as possible to the right. Repeat behind.

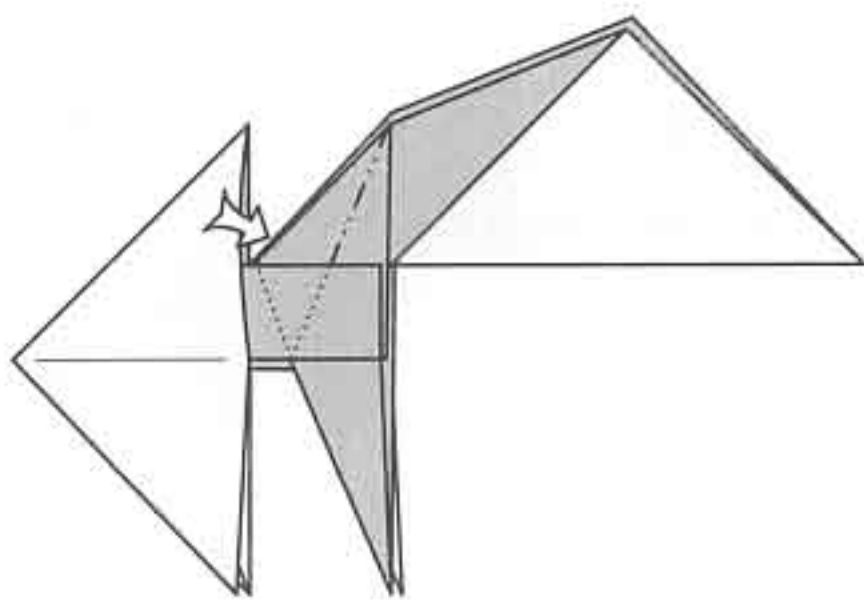

29 Sink the edge.

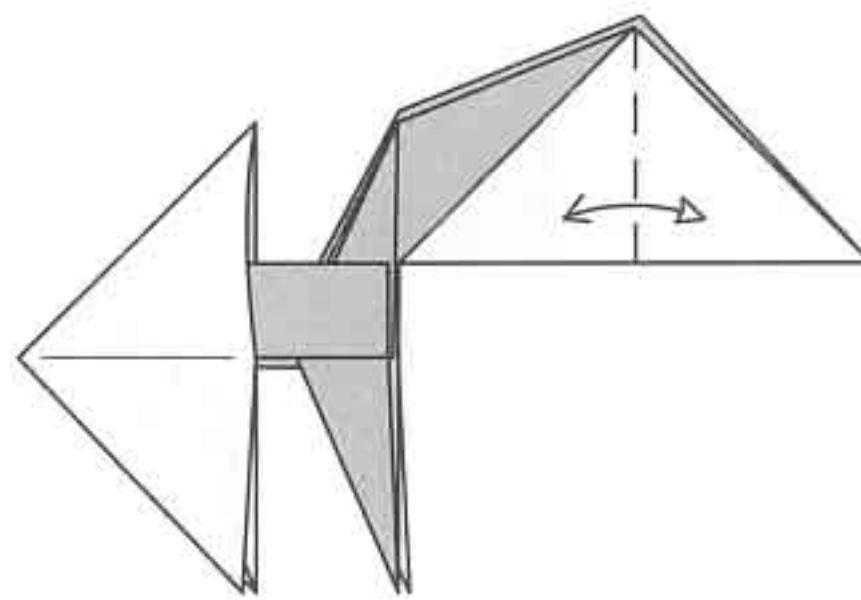

30 Fold and unfold.

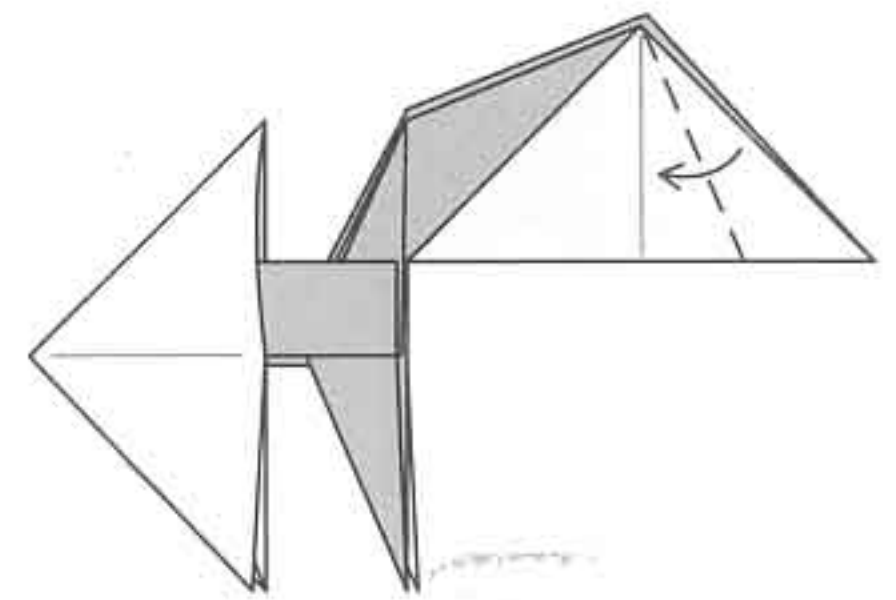

31 Fold the edge down to the crease.

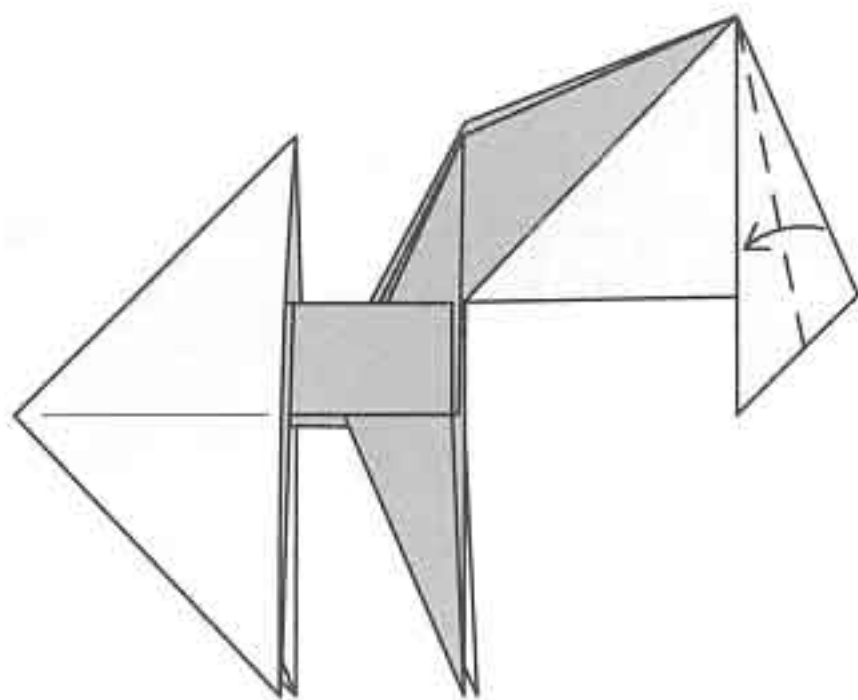

32 Fold the edge over.

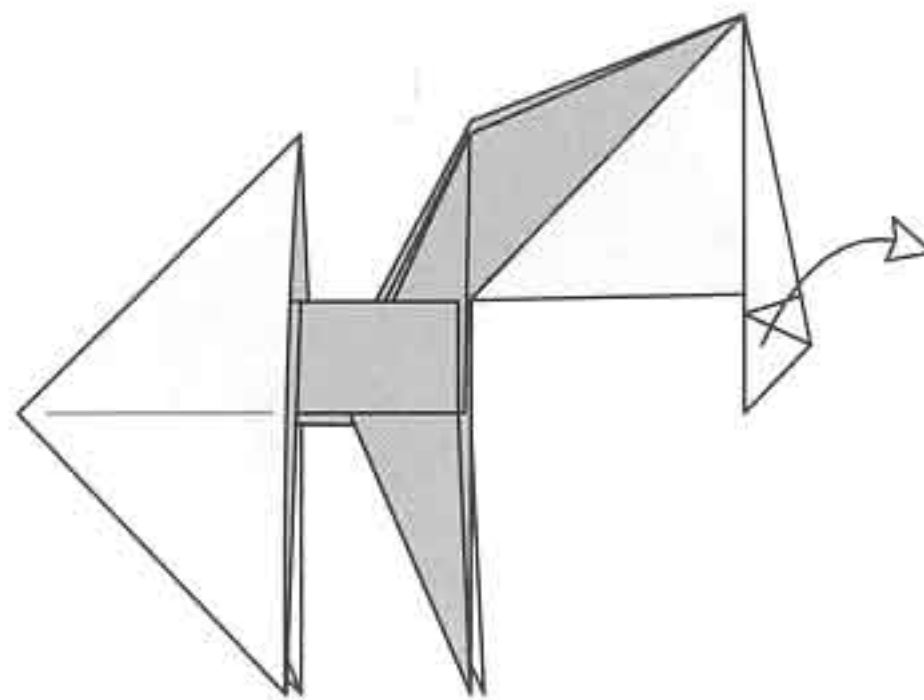

33 Unfold.

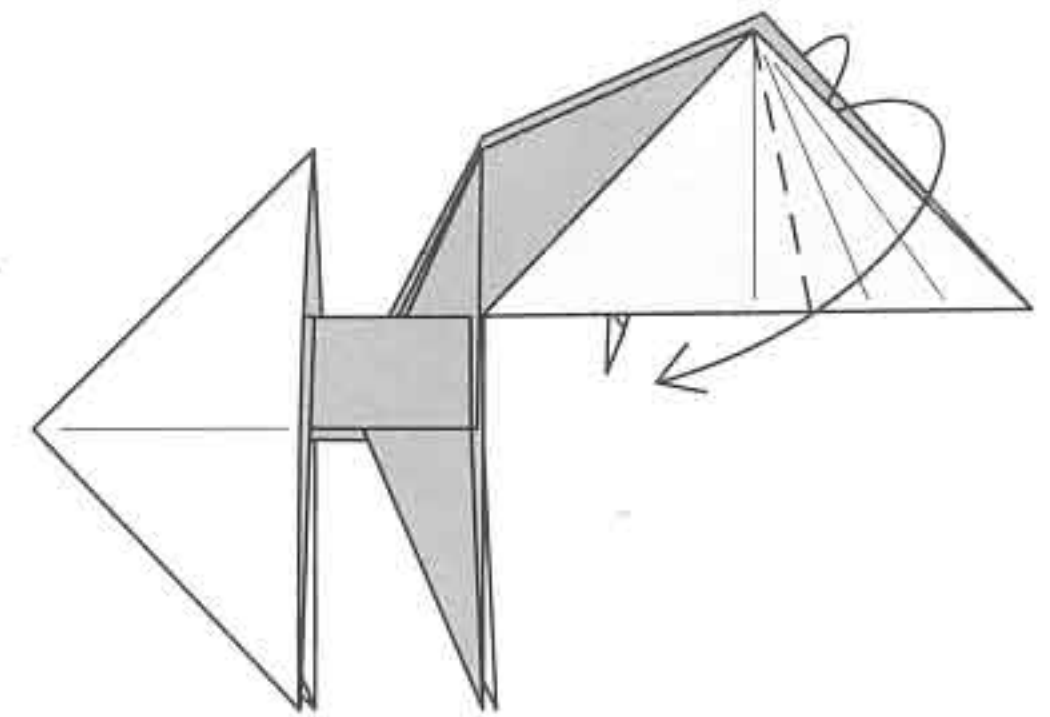

34 Outside reverse-fold on existing creases.

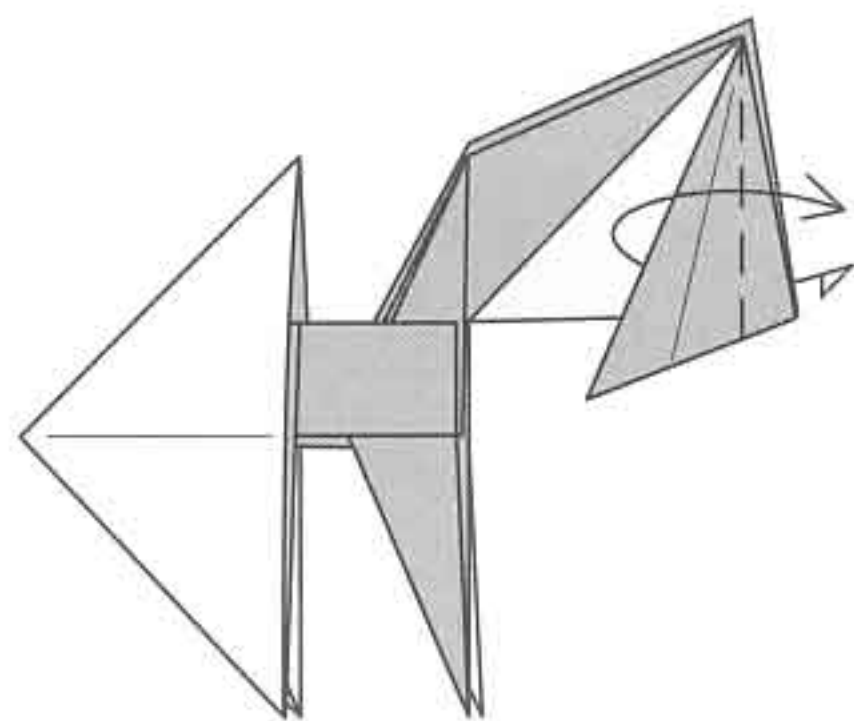

35 Outside reverse-fold again on existing creases.

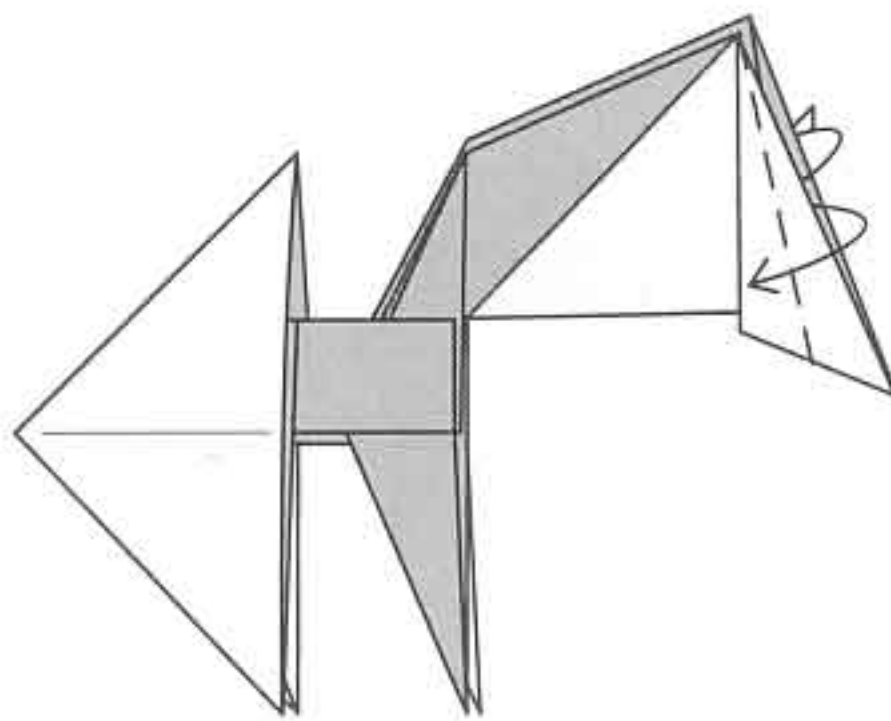

36 Outside reverse-fold one last time.

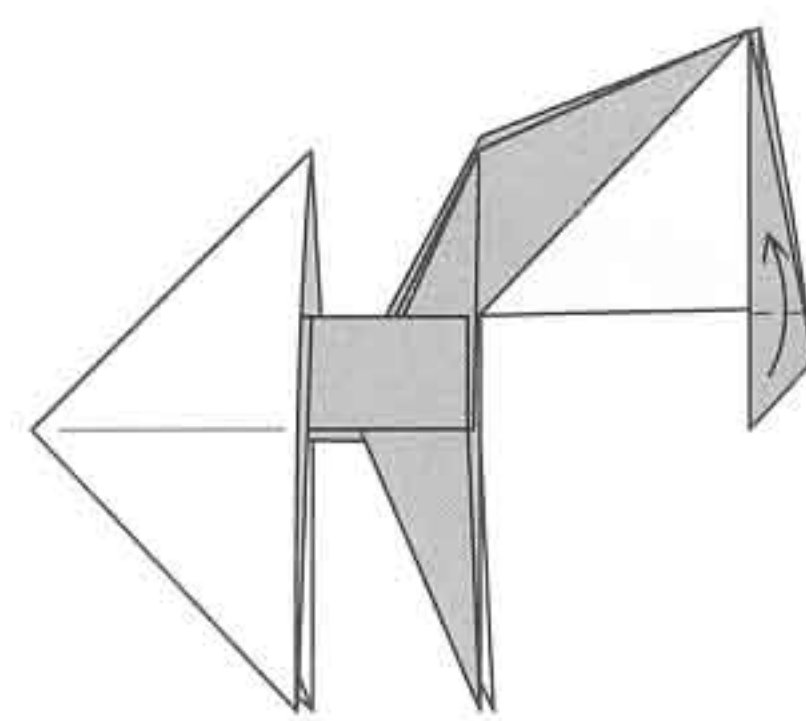

37 Fold the tip up.

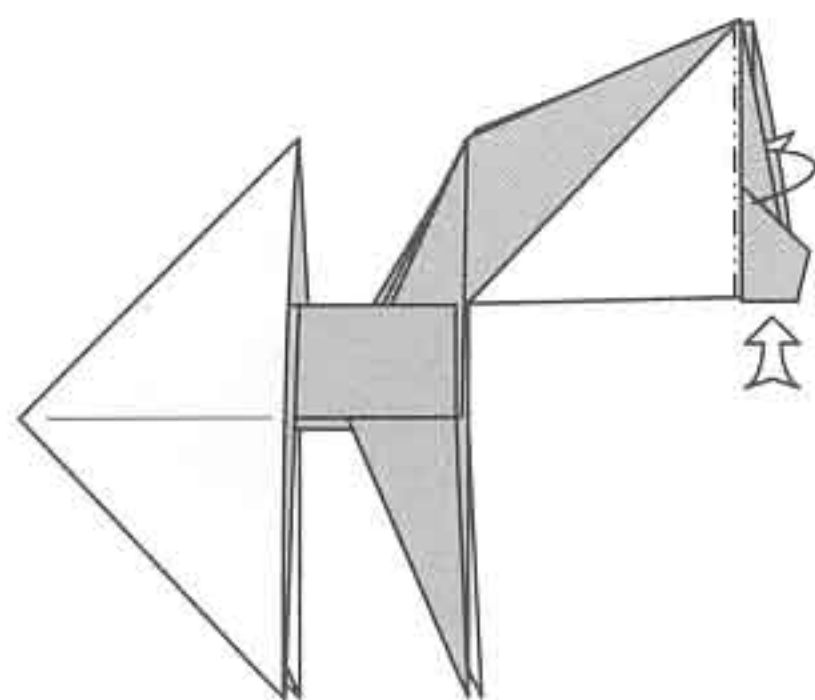

38 Reverse-fold.

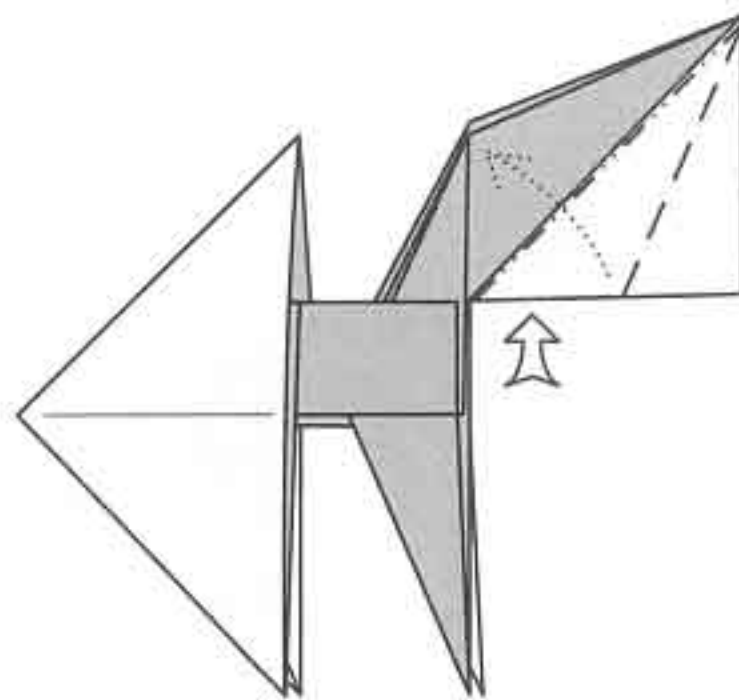

39 Reverse-fold back and forth.

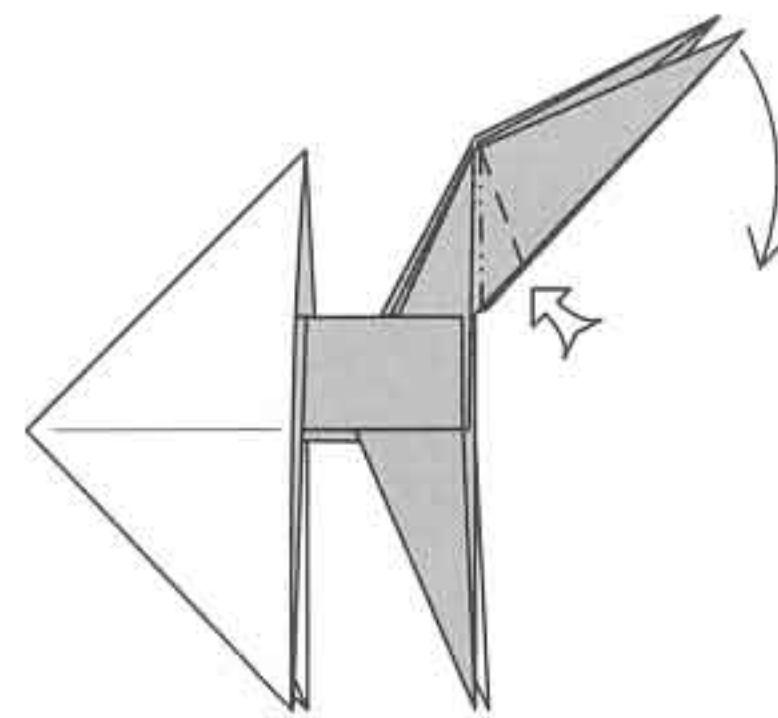

40 Spread the three points, two to one side, one to the other, and reverse-fold in and out. The base of the middle point will be locked to one of the other two points.

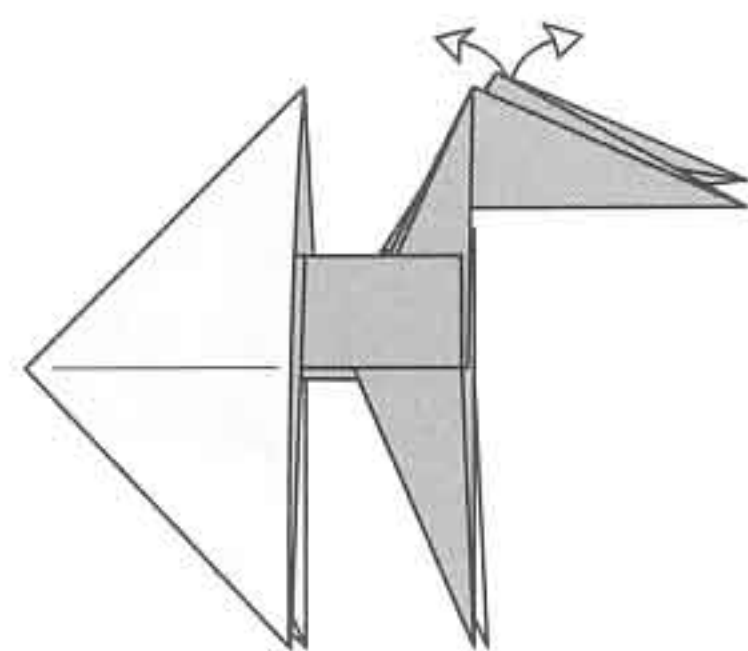

41 Rearrange the layers at the top so that the three flaps are separated; you will have to turn some valley folds into mountain folds and vice-versa.

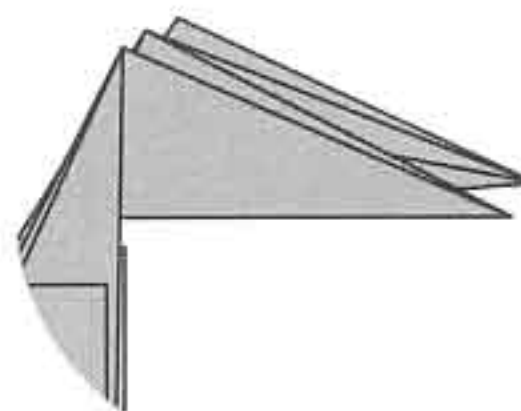

42 This is a close-up view of the result.

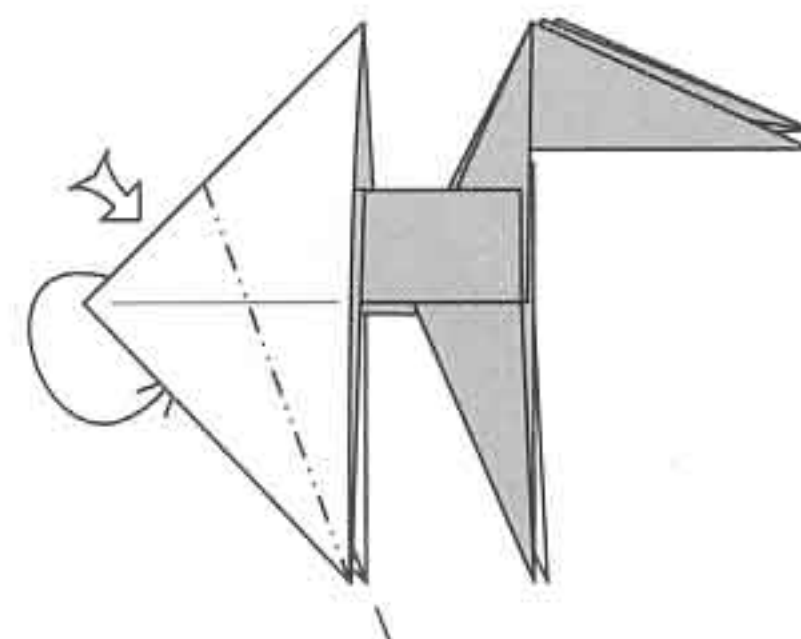

43 Reverse-fold the left side.

gazelle

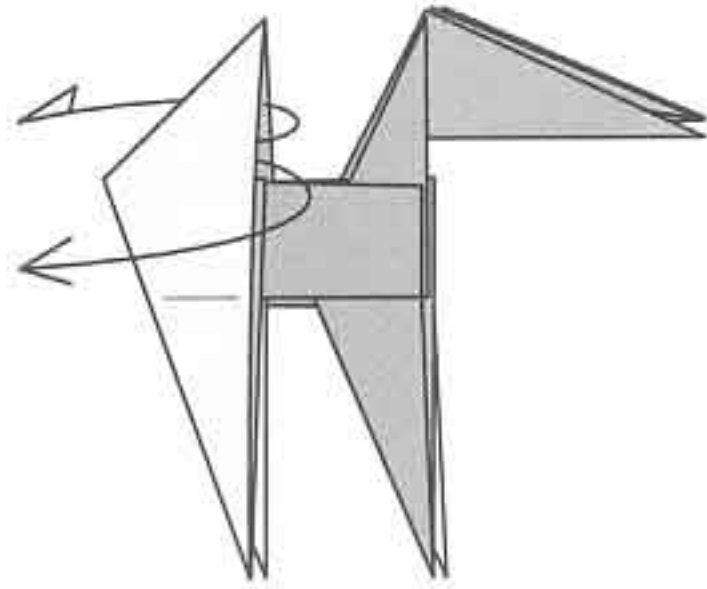

44 Unwrap the white flap.

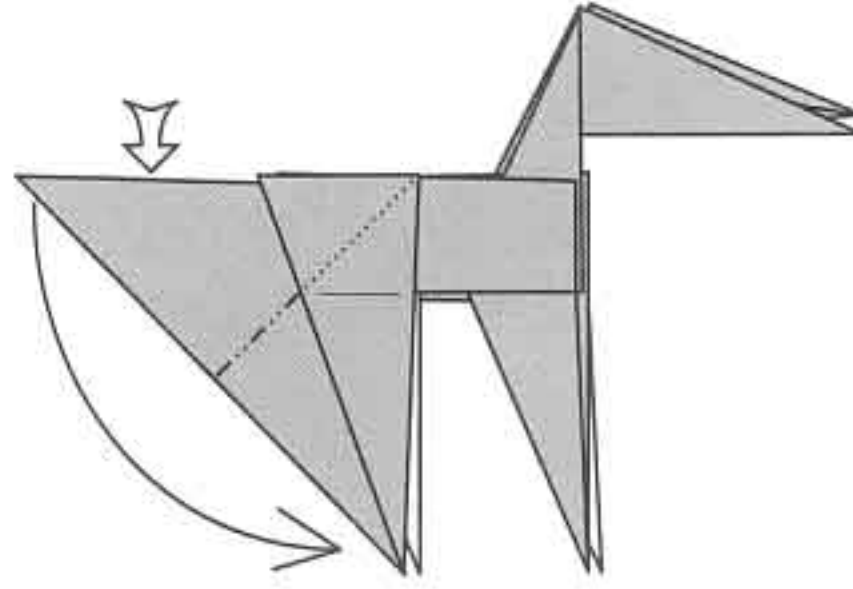

45 Reverse-fold the point downward.

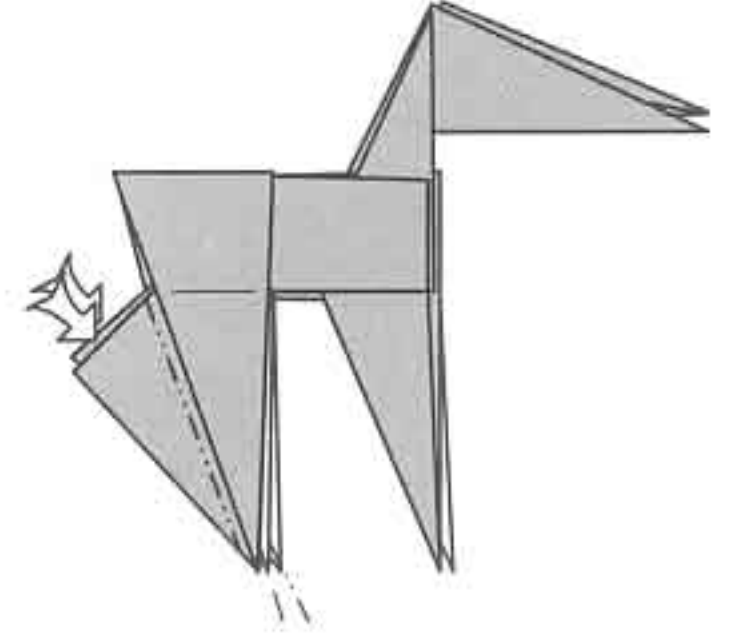

46 Reverse-fold both edges.

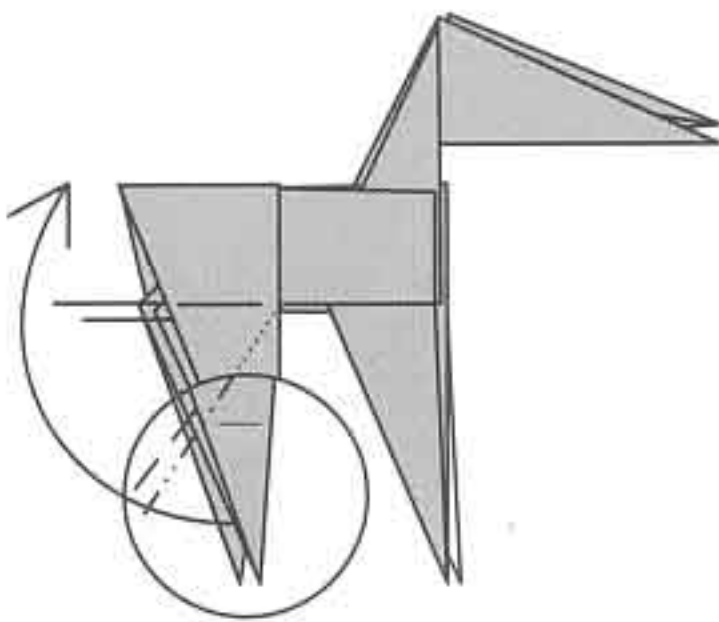

47 Crimp the tail (the middle point of three) upward as far as possible.

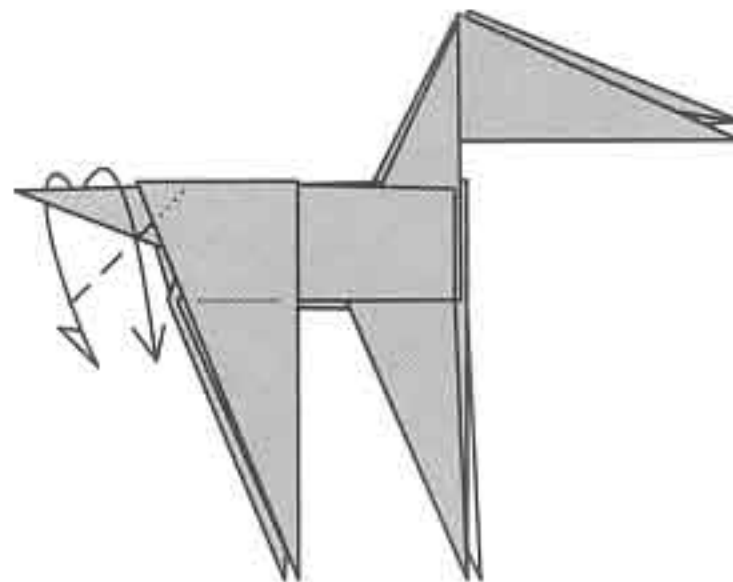

48 Outside reverse-fold the tail downward.

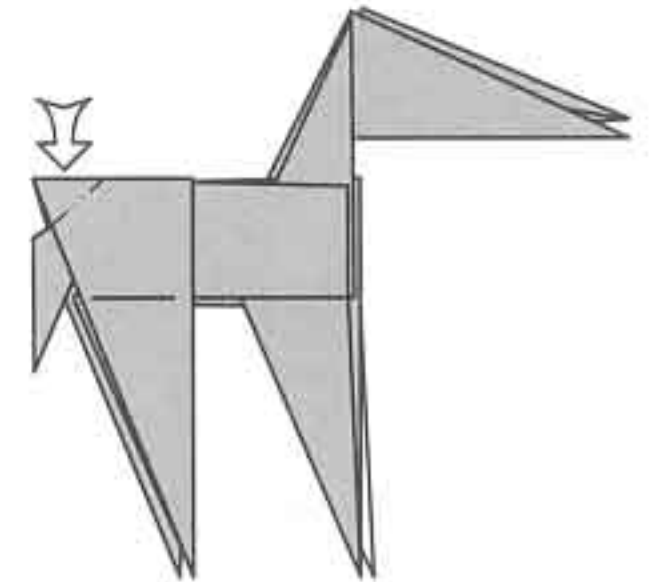

49 Reverse-fold the corner of the rump down inside the tail.

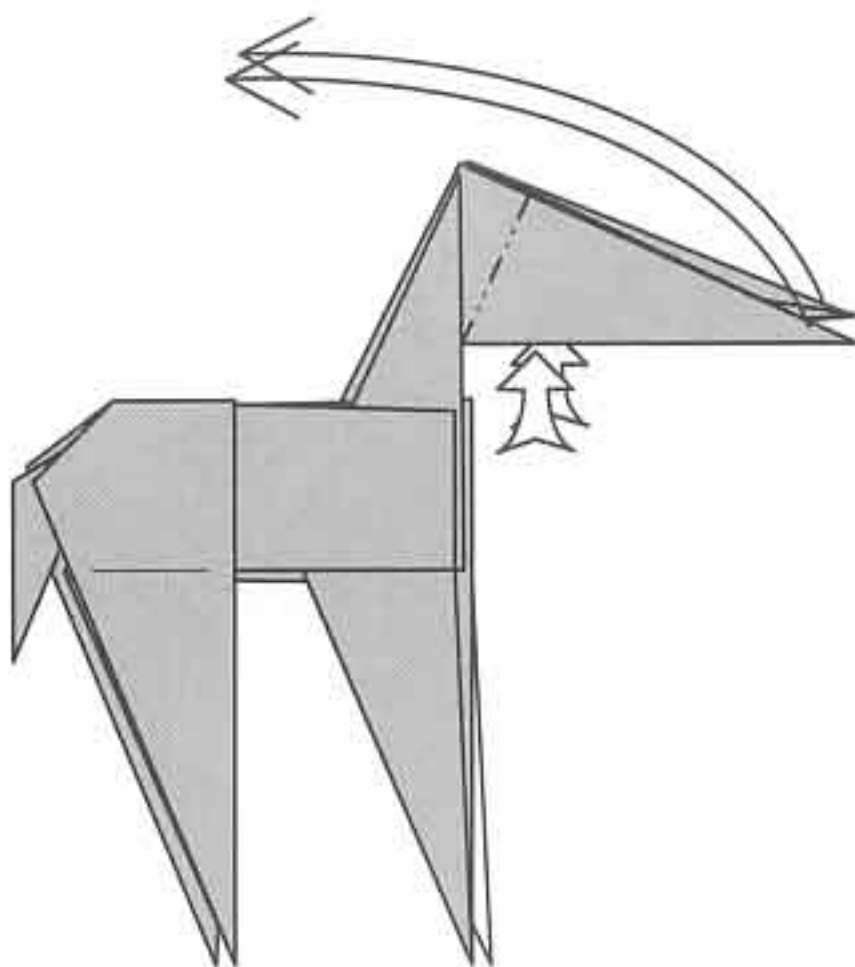

50 Reverse-fold the two points up to the left.

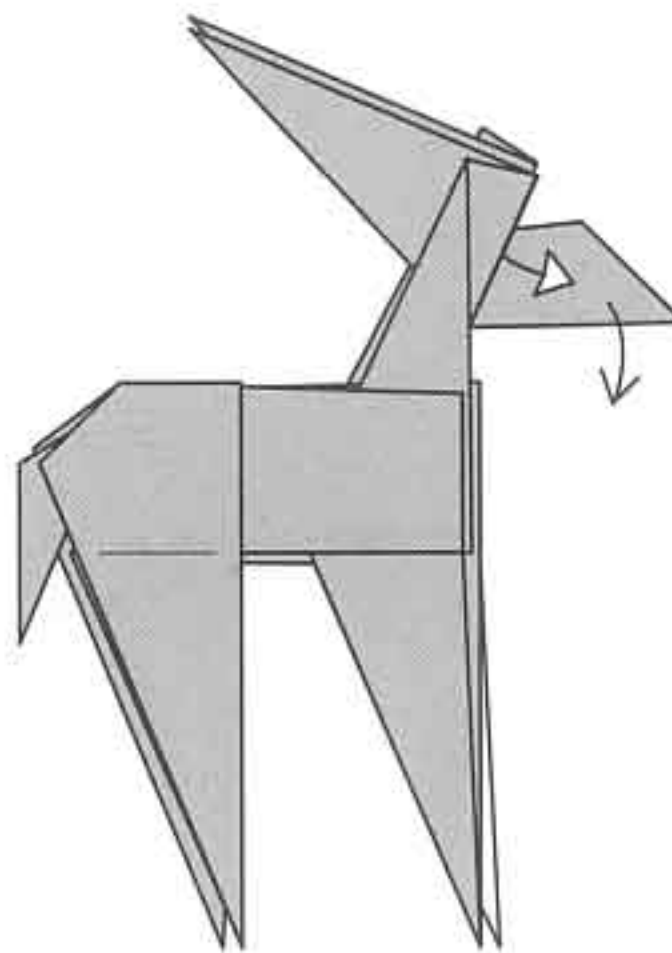

51 Pivot the head down.

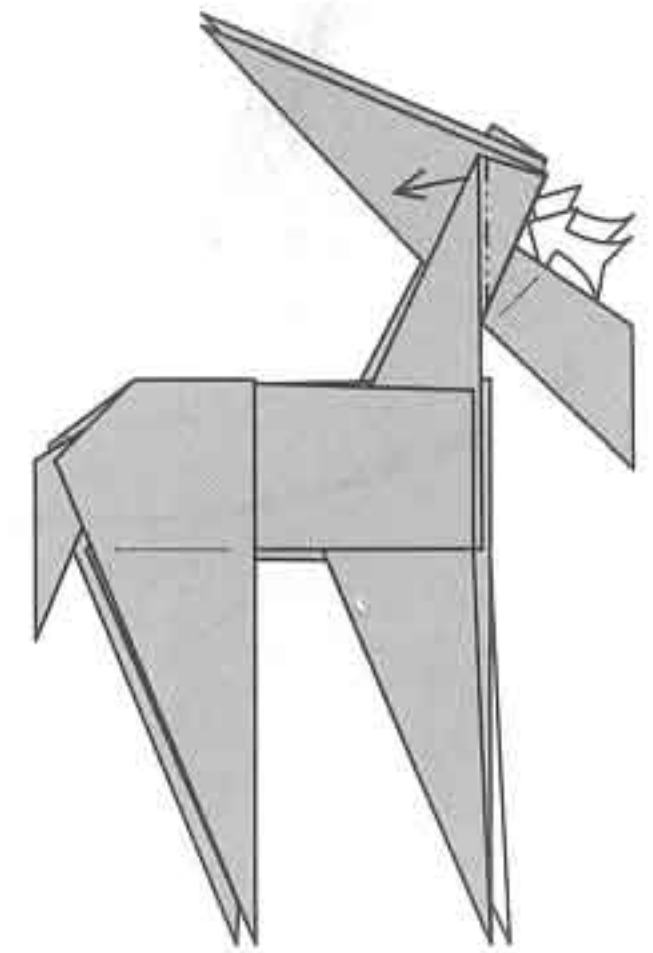

52 Reverse-fold the edge. Repeat behind.

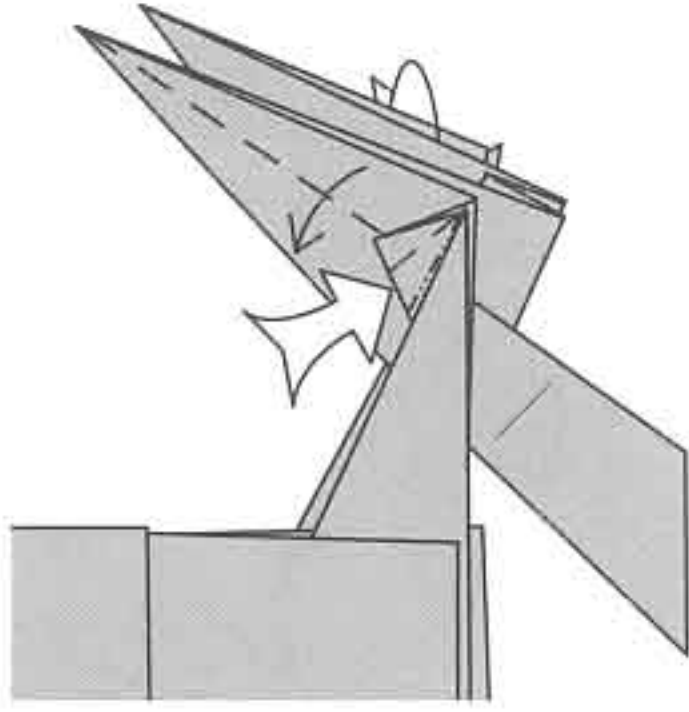

53 Valley-fold the long edge and simultaneously reverse-fold the corner near the head (you must do these together). Repeat behind.

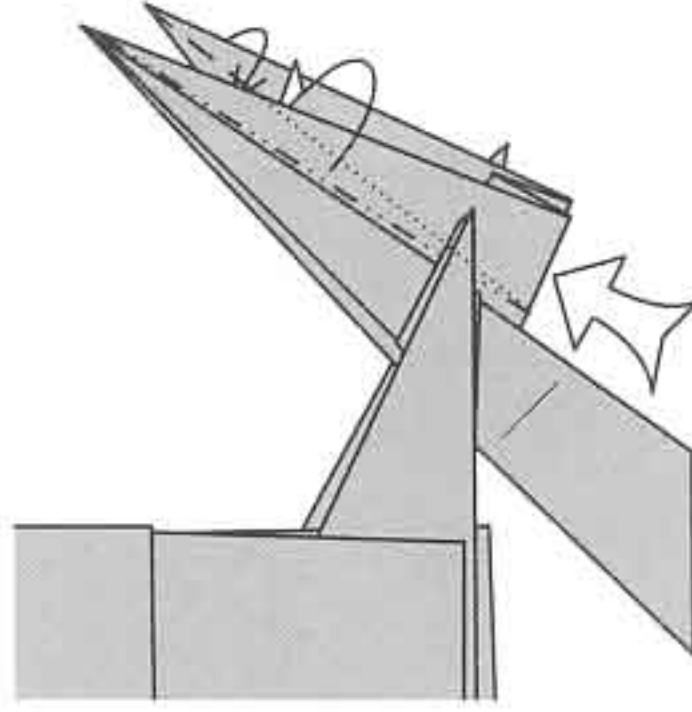

54 Fold the middle layer over to one side and reverse-fold the forehead to narrow the horns.

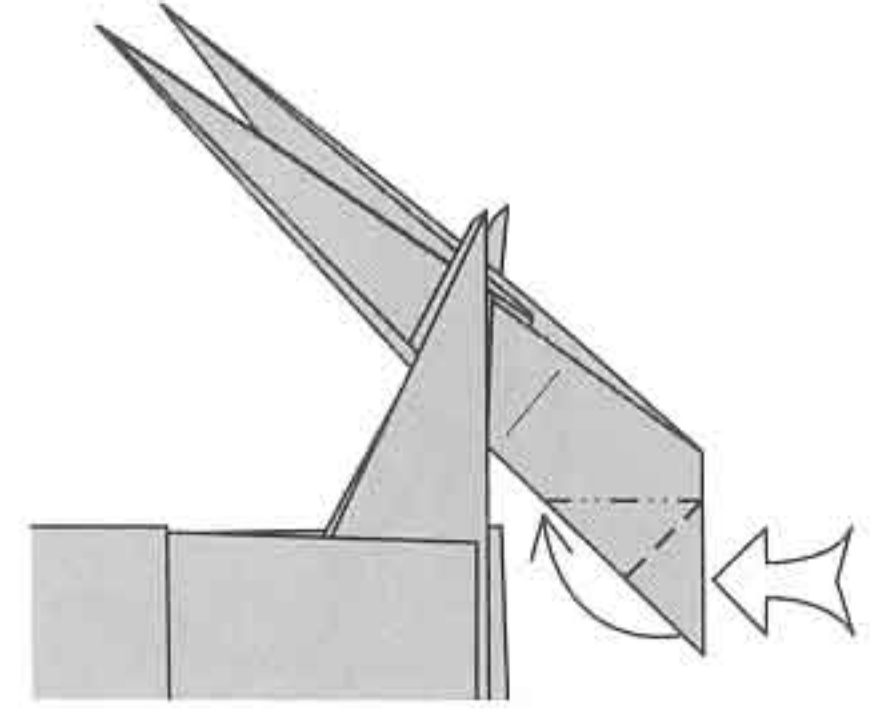

55 Reverse-fold the nose.

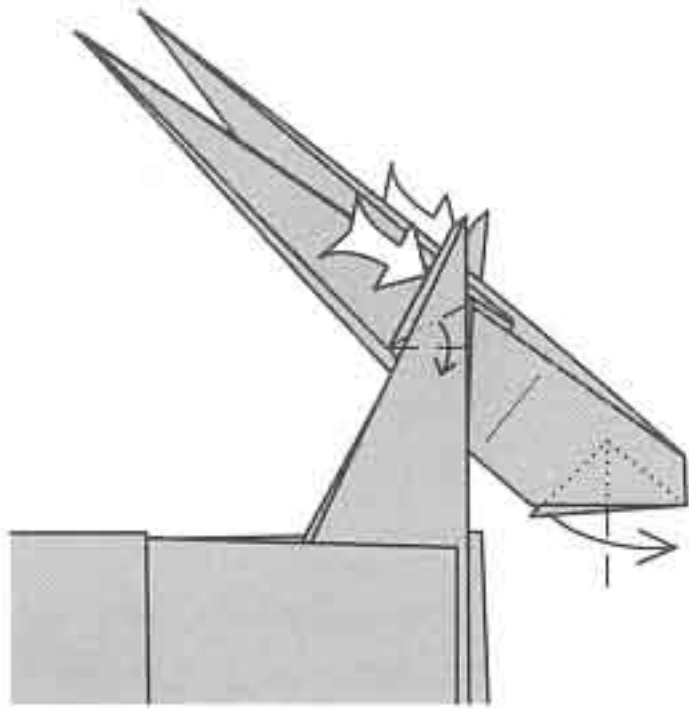

56 Valley-fold the point forward to make a jaw. Squash-fold the ear; repeat behind.

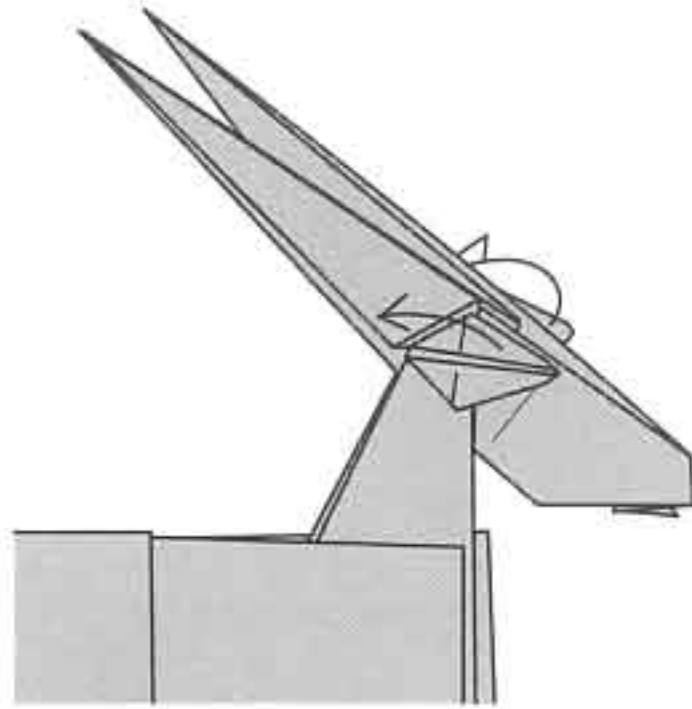

57 Valley-fold the ear backward. Repeat behind.

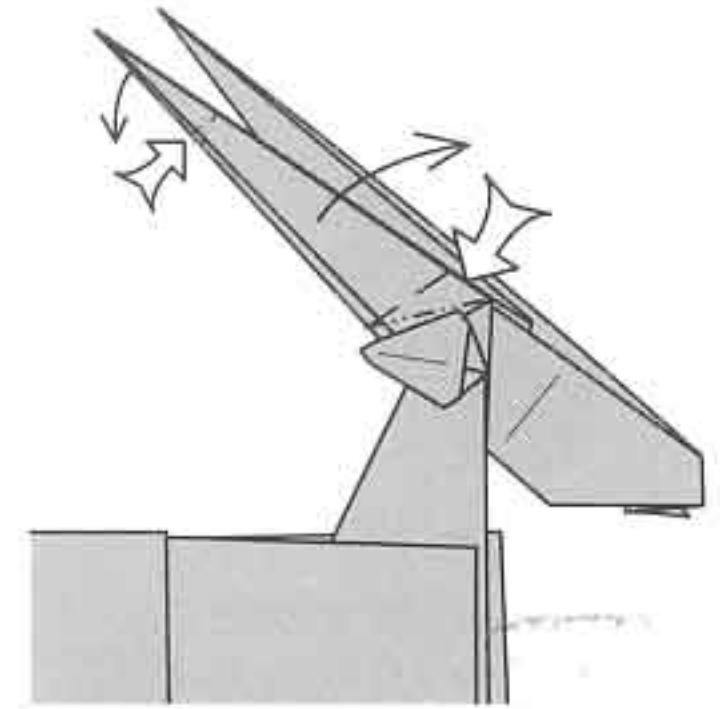

58 Crimp the horns in two places.

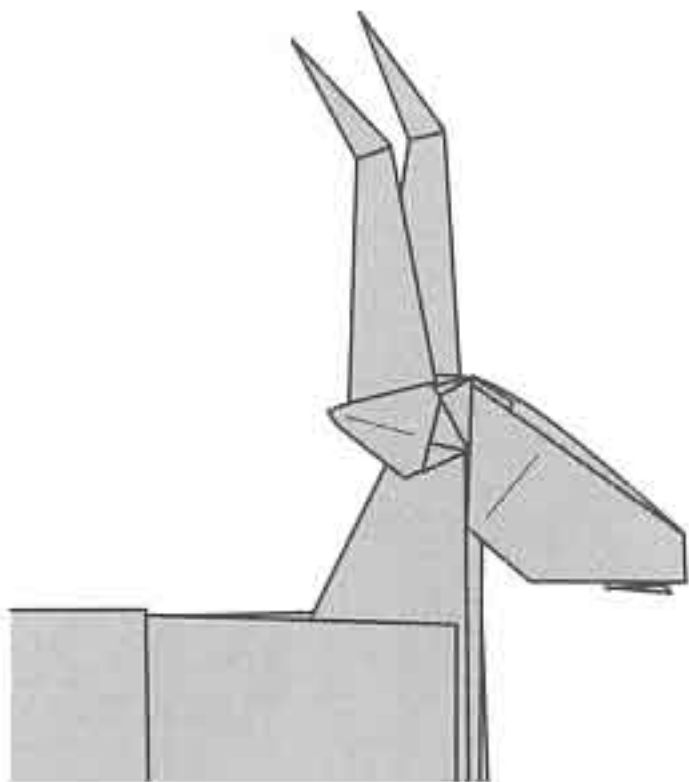

59 Like this. By varying the location and size of the crimps, you can get many different species of antelope and gazelle.

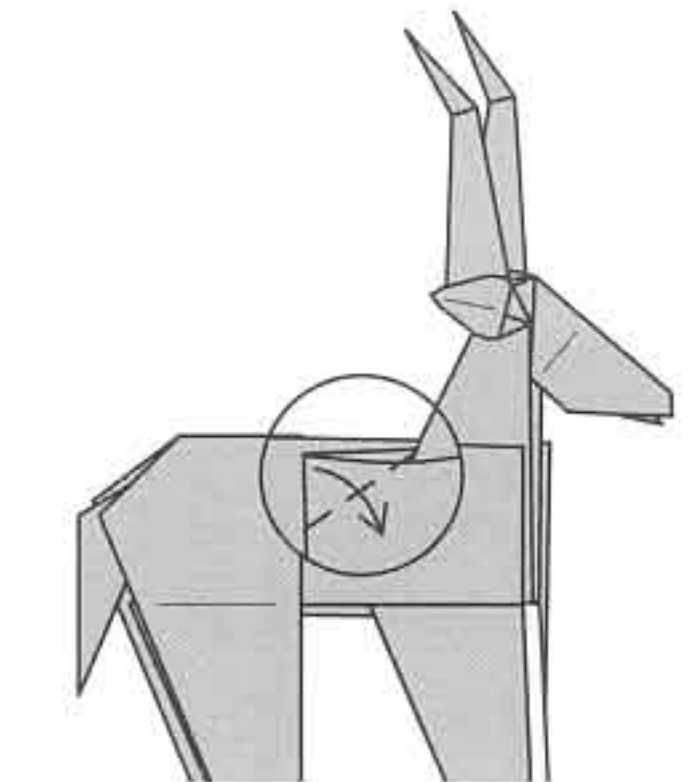

60 Valley-fold the hidden corner over to lock the back.

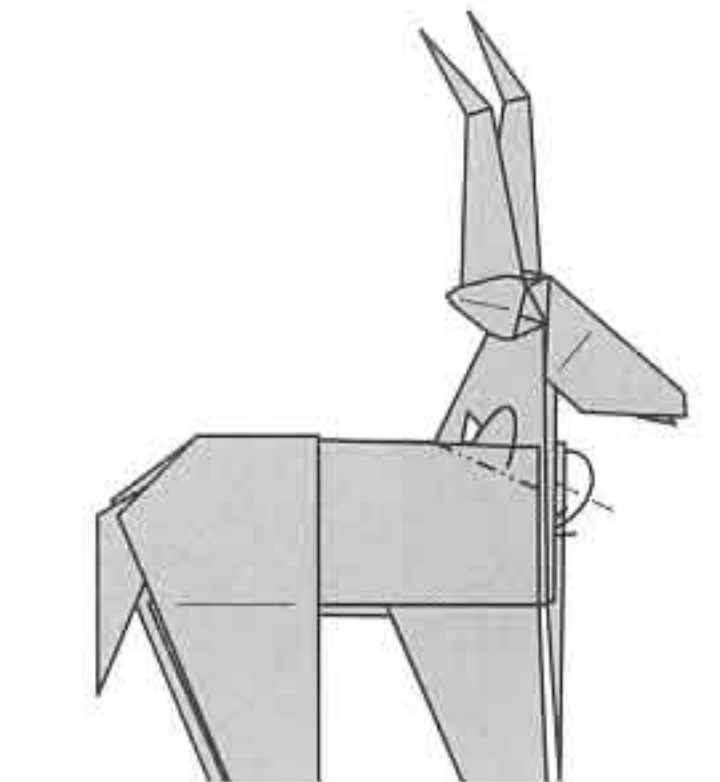

61 Mountain-fold the shoulder. Repeat behind.

gazelle

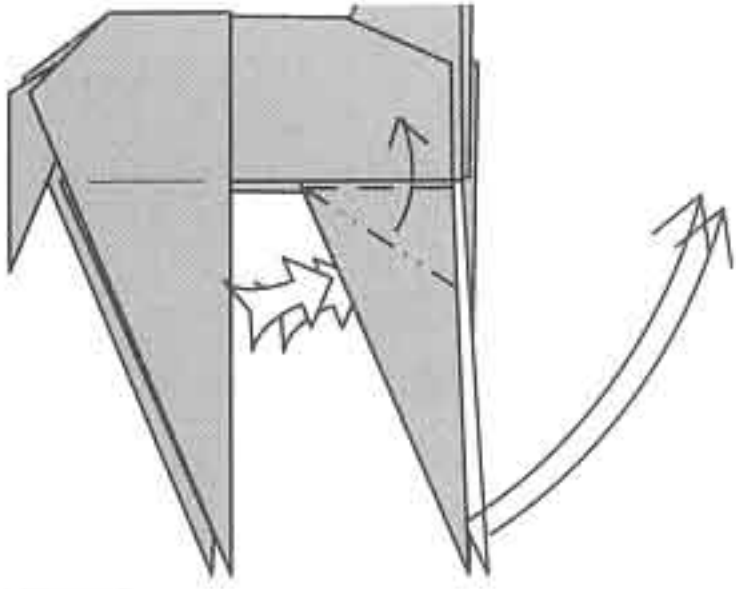

62 Squash-fold the forelegs.

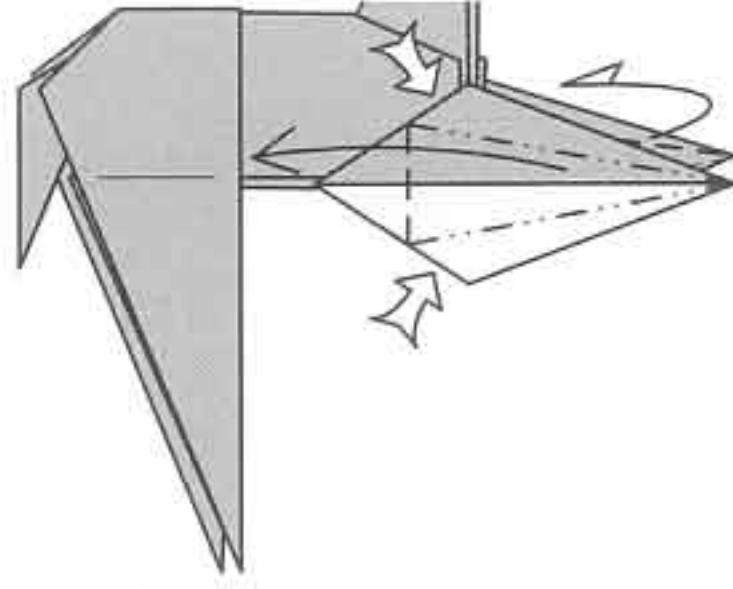

63 Petal-fold the forelegs.

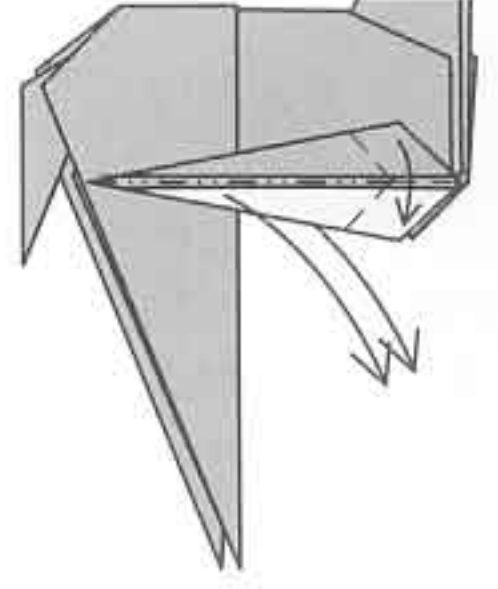

64 Close up and reverse-fold the legs downward.

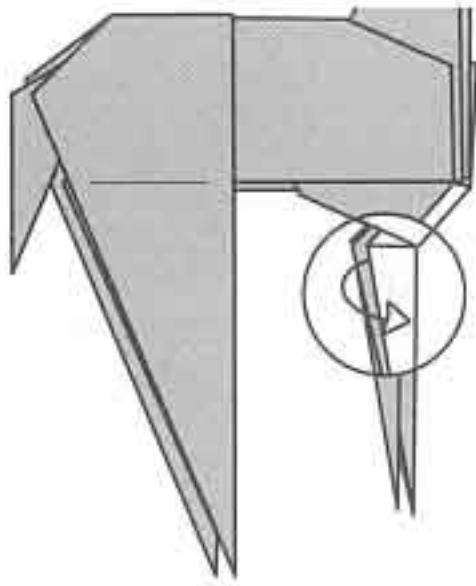

65 Tuck the white part of each leg inside the colored part; the far leg is shown in the cut-away view.

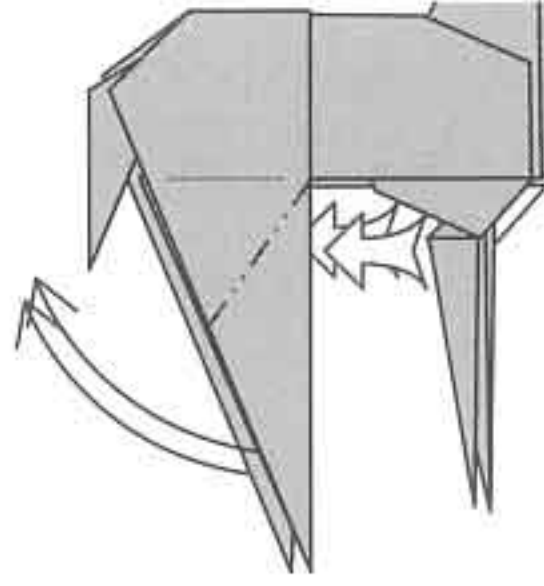

66 Reverse-fold the hind legs.

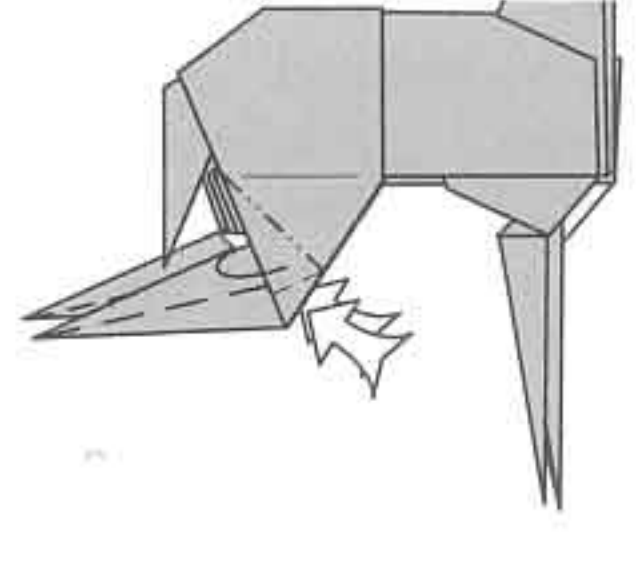

67 Narrow the legs with reverse folds.

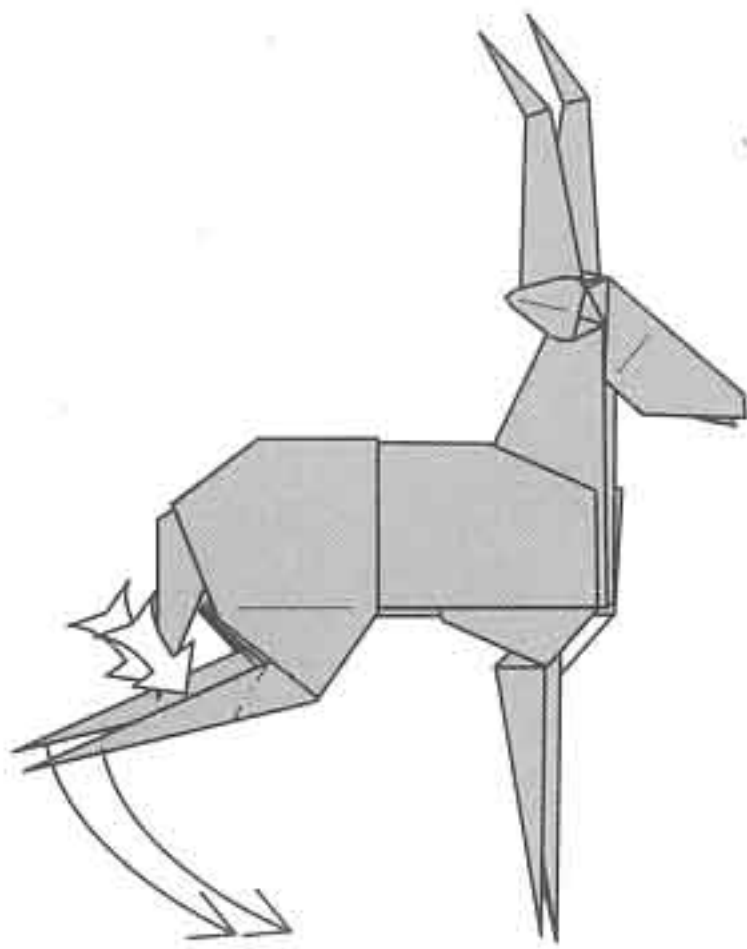

68 Reverse-fold the legs downward.

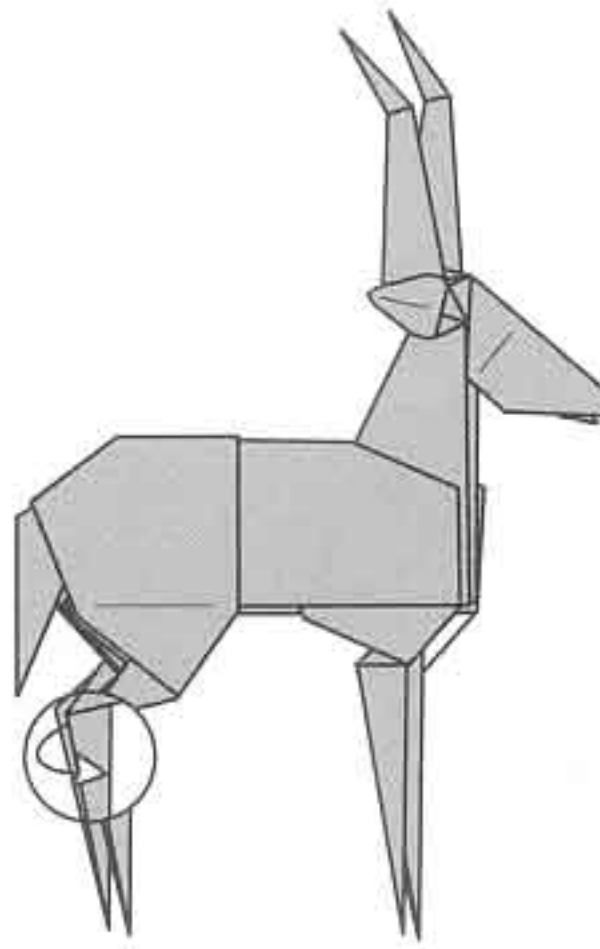

69 Tuck the inside flap of each leg into the outside flap. The far leg is shown here in cut-away view.

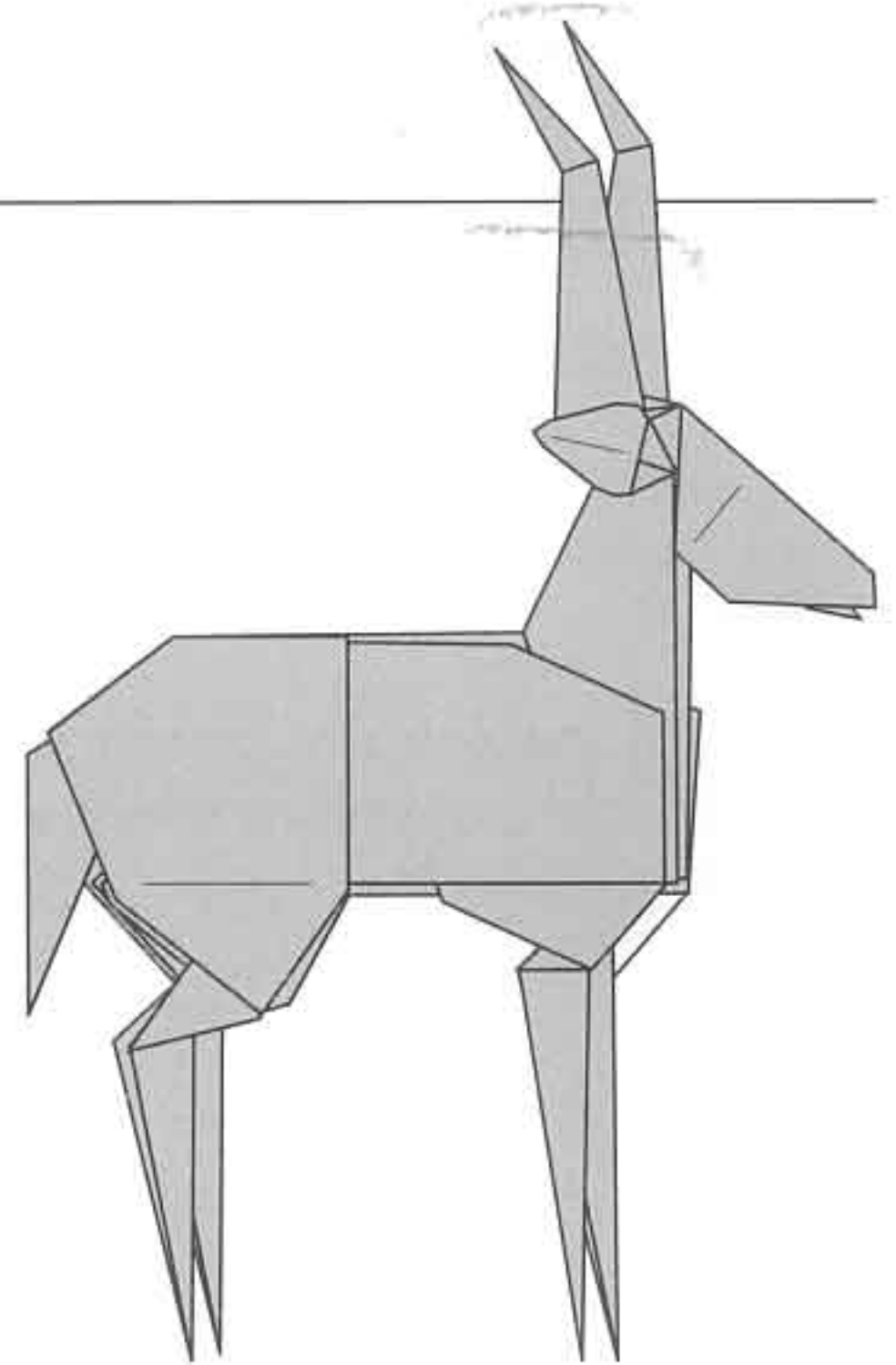

Finished Gazelle.