

Technical drawings – General principles of presentation
Part 23: Lines on construction drawings
(ISO 128-23 : 1999)

DIN
ISO 128-23

ICS 01.100.30

Technische Zeichnungen – Allgemeine Grundlagen der Darstellung – Teil 23: Linien in Zeichnungen des Bauwesens (ISO 128-23 : 1999)

This standard incorporates International Standard

ISO 128-23 Technical drawings – General principles of presentation – Part 23: Lines on construction drawings.

A comma is used as the decimal marker.

National foreword

This standard has been prepared by ISO/TC 10.

The responsible German body involved in its preparation was the *Normenausschuss Technische Grundlagen* (Fundamentals in Technology Standards Committee).

The DIN Standards corresponding to the International Standards referred to in clause 2 of the ISO Standard are as follows:

ISO Standard	DIN Standard(s)
ISO 128-20	DIN ISO 128-20
ISO 129	DIN 406-10 and DIN 406-11
ISO 3766	DIN ISO 3766
ISO 4069	DIN ISO 4069
ISO 6428	DIN ISO 6428
ISO 7519	DIN ISO 7519
ISO 8048	DIN 6-1, DIN 6-2, and DIN 1356-1
ISO 8560	DIN ISO 8560
ISO 11091	DIN EN ISO 11091



National Annex NA Standards referred to

(and not included in **Normative references**)

DIN 6-1	Technical drawings – Representation in normal projection – Views and special representations
DIN 6-2	Technical drawings – Representation in normal projection – Sectional views
DIN 406-10	Engineering drawing practice – Dimensioning – Concepts and general principles
DIN 406-11	Engineering drawing practice – Dimensioning – Principles of application
DIN 1356-1	Construction drawings – Types and principles of representation
DIN EN ISO 11091	Construction drawings – Landscape drawing practice (ISO 11091 : 1994)
DIN ISO 128-20	Technical drawings – General principles of presentation – Part 20: Basic conventions for lines (ISO 128-20 : 1996)
DIN ISO 6428	Technical drawings – Requirements for microcopying (ISO 6428 : 1982)

ISO Standard comprises 14 pages.

Technical drawings – General principles of presentation

Part 23: Lines on construction drawings

Contents

1 Scope	3
2 Normative references	3
3 General principles.....	4
4 Types of lines and their applications.....	4
5 Line widths	6
Annex A (informative) Examples of application	8

Foreword

ISO (the International Organization for Standardization) is a worldwide federation of national standards bodies (ISO member bodies). The work of preparing International Standards is normally carried out through ISO technical committees. Each member body interested in a subject for which a technical committee has been established has the right to be represented on that committee. International organizations, governmental and non-governmental, in liaison with ISO, also take part in the work. ISO collaborates closely with the International Electrotechnical Commission (IEC) on all matters of electrotechnical standardization.

International Standards are drafted in accordance with the rules given in ISO/IEC Directives, Part 3.

Draft International Standards adopted by the technical committees are circulated to the member bodies for voting. Publication as an International Standard requires approval by at least 75 % of the member bodies casting a vote.

International Standard ISO 128-23 was prepared by Technical Committee ISO/TC 10, *Technical drawings, product definition and related documentation*, Subcommittee SC 8, *Construction documentation*.

This first edition is based on ISO 128:1982, clause 3, and it replaces the rules specified in that clause.

ISO 128 consists of the following parts, under the general title *Technical drawings — General principles of presentation*:

- *Part 20: Basic conventions for lines*
- *Part 21: Preparation of lines by CAD systems*
- *Part 22: Basic conventions and applications for leader lines and reference lines*
- *Part 23: Lines on construction drawings*
- *Part 24: Lines on mechanical engineering drawings*
- *Part 25: Lines on shipbuilding drawings*
- *Part 30: Basic convention for views*
- *Part 50: Basic conventions for representing areas on cuts and sections*

NOTE Further parts of ISO 128 are planned, covering other general principles of presentation including those for application of lines within drawings of various technical fields.

Annex A of this part of ISO 128 is for information only.

Introduction

The basic conventions and the application of lines in respect to other fields of drawing practice are presented in other parts of ISO 128 since requirements in industry vary considerably. For further information, see ISO 128-20.

1 Scope

This part of ISO 128 specifies types of lines and their application in construction documentation comprising architectural drawings, structural engineering drawings, building service engineering drawings, civil engineering drawings, landscape drawings and town planning drawings.

2 Normative references

The following normative documents contain provisions which, through reference in this text, constitute provisions of this part of ISO 128. For dated references, subsequent amendments to, or revisions of, any of these publications do not apply. However, parties to agreements based on this part of ISO 128 are encouraged to investigate the possibility of applying the most recent editions of the normative documents indicated below. For undated references, the latest edition of the normative document referred to applies. Members of ISO and IEC maintain registers of currently valid International Standards.

ISO 128-20:1996, *Technical drawings — General principles of presentation — Part 20: Basic conventions for lines.*

ISO 129:1985, *Technical drawings — Dimensioning — General principles, definitions, methods of execution and special indications.*

ISO 3766:1995, *Construction drawings — Simplified representation of concrete reinforcement.*

ISO 4068:1978, *Building and civil engineering drawings — Reference lines.*

ISO 4069:1977, *Building and civil engineering drawings — Representation of areas on sections and views — General principles.*

ISO 4463-1:1989, *Measurement methods for building — Setting-out and measurement — Part 1: Planning and organization, measuring procedures, acceptance criteria.*

ISO 6428:1982, *Technical drawings — Requirements for microcopying.*

ISO 7519:1991, *Technical drawings — Construction drawings — General principles of presentation for general arrangement and assembly drawings.*

ISO 8048:1984, *Technical drawings — Construction drawings — Representation of views, sections and cuts.*

ISO 8560:1986, *Technical drawings — Construction drawings — Representation of modular sizes, lines and grids.*

ISO 11091:1994, *Construction drawings — Landscape drawing practice.*

3 General principles

The types of lines, their designations and their dimensions as well as general rules for draughting of lines are specified in ISO 128-20.

The requirements for microcopying are specified in ISO 6428.

4 Types of lines and their applications

The first part of the number is the number of line type in ISO 128-20.

Examples of applications are shown in annex A.

Table 1 — Types of lines and their application



No.	Description and representation	Application	Reference to ISO
01.1	Continuous narrow line 	.1 boundaries of different materials in view, cut and section (alternatively, see 01.2.2)	7519
		.2 hatching	4069
		.3 diagonals for indication of openings, holes and recesses	7519
		.4 arrow lines in stairs, ramps and sloping areas	7519
		.5 modular grid lines, first stage (if necessary, other colour than outlines)	8560
		.6 short centrelines	—
		.7 extension lines	129
		.8 dimension lines and their terminators	129
		.9 leader lines	129
		.10 existing contours on landscape drawings (alternatively, see 02.1.1)	11091
		.11 visible outlines of parts in view (alternatively, see 01.2.3)	—
		.12 simplified representation of doors, windows, stairs, fittings etc. (alternatively, see 01.2.4)	7519
			Continuous narrow lines with zigzags 

Table 1 (continued)













No.	Description and representation	Application	Reference to ISO
01.2	Continuous wide line 	.1 visible outlines of parts in cut and section when hatching is used	7519
		.2 boundaries of different materials in view, cut and section (alternatively, see 01.1.1)	—
		.3 visible outlines of parts in view (alternatively, see 01.1.11)	7519
		.4 simplified representation of doors, windows, stairs, fittings etc. (alternatively, see 01.1.12)	7519
		.5 modular grid lines, second stage (if necessary other colour than outlines)	8560
		.6 arrow lines for marking of views, cuts and sections	8048
		.7 proposed contours on landscape drawings	11091
01.3	Continuous extra-wide line 	.1 visible outlines of parts in cut and section when hatching is not used	7519
		.2 reinforcing bars (see 02.3.1)	3766
		.3 lines of special importance	—
02.1	Dashed narrow line 	.1 existing contours on landscape drawings (alternatively, see 01.1.10)	11091
		.2 subdivision of plant beds/grass	11091
		.3 hidden outlines (alternatively, see 02.2.1)	—
02.2	Dashed wide line 	.1 hidden outlines (alternatively, see 02.1.3)	—
02.3	Dashed extra-wide line 	.1 reinforcing bars in bottom layer on plan and far face layer in elevation when bottom and top layers and near and far face layers are shown on the same sketch	3766
04.1	Long dashed dotted narrow line 	.1 cutting planes (line 04.2 at ends and changes of direction)	—
		.2 centrelines	—
		.3 lines of symmetry (identified at the ends by two narrow short parallel lines drawn at right angle)	—
		.4 framing of enlarged details	—
		.5 reference lines	—
		.6 limits of partial or interrupted views, cuts and sections (especially for short lines and in narrow situations; see examples 01.1.2, 01.2.1, 01.3.1, etc., in annex A; alternatively, see 01.1.14)	—

Table 1 (continued)

No.	Description and representation	Application	Reference to ISO
04.2	Long dashed dotted wide line 	.1 cutting planes (at ends and changes of direction; see 04.1.1)	—
		.2 outlines of visible parts situated in front of the cutting plane	—
04.3	Long dashed dotted extra-wide line 	.1 secondary lines for setting out and arbitrary reference lines	4463-1;4068
		.2 indication of lines or surfaces to which a special requirement applies	—
		.3 boundary lines for contracts, stages, zones etc.	—
05.1	Long dashed double-dotted narrow line 	.1 alternative and extreme positions of movable parts	—
		.2 centroidal line	—
		.3 outlines of adjacent parts	—
05.2	Long dashed double-dotted wide line 	.1 outlines of hidden parts situated in front of the cutting plane	—
05.3	Long dashed double-dotted extra-wide line 	.1 reinforcing prestressed bars and cables	3766
07.1	Dotted narrow line 	.1 outlines of parts not included in the project	—

5 Line widths

On a construction drawing three line widths, narrow, wide and extra-wide, are normally used (see Table 2).

The proportions between the line widths are 1:2:4.

A special line width is used for representation and lettering of graphical symbols. This line width is situated between the width of the narrow and the wide line.

Table 2 — Line widths

Dimensions in millimetres

Line group	Narrow line	Wide line	Extra-wide line	Line widths for graphical symbols
0,25	0,13	0,25	0,5	0,18
0,35	0,18	0,35	0,7	0,25
0,5	0,25	0,5	1	0,35
0,7	0,35	0,7	1,4	0,5
1	0,5	1	2	0,7

The line widths shall be chosen according to the type, size and scale of the drawing and the requirements at microcopying and other methods of reproduction.

Annex A (informative)

Examples of application

Examples of the application of the different types of lines, along with the corresponding reference numbers from clause 4, are given in Table A.1.

Table A.1 — Examples of application

No.	Line type	Example of application
01.1	Continuous narrow line	
01.1.1	Boundaries of different materials in view, cut and section	 <p style="text-align: center;">View of a floor with different materials</p>
01.1.2	Hatching	 <p style="text-align: center;">Vertical section of a wall</p>
01.1.3	Diagonals for indication of openings, holes and recesses	 <p style="text-align: center;">View of a wall with an opening</p>
01.1.4	Arrow lines in stairs, ramps and sloping areas	 <p style="text-align: center;">Stair Ramp</p>
01.1.5	Modular grid lines, first stage	 <p style="text-align: center;">Line 01.1</p>

Table A.1 (continued)

No.	Line type	Example of application
01.1.6	Short centrelines	
01.1.7 01.1.8 01.1.9	Extension lines Dimension lines and their terminators Leader lines	
01.1.10	Existing contours on landscape drawings	
01.1.11	Visible outlines of parts in view (alternatively, see 01.2.3)	
01.1.12	Simplified representation of doors, windows, stairs, fittings etc. (alternatively, see 01.2.4)	
01.1.13	Framing of details	
01.1.14	Limits of partial or interrupted views, cuts and sections, if the limit is not a line 04.1	

Table A.1 (continued)

No.	Line type	Example of application
01.2	Continuous wide line	
01.2.1	Visible outlines of parts in cut and section when hatching is used	
01.2.2	Boundaries of different materials in view, cut and section	
01.2.3	Visible outlines of parts in view (alternatively, see 01.1.11)	
01.2.4	Simplified representation of doors, windows, stairs, fittings etc. (alternatively, see 01.1.12)	
01.2.5	Modular grid lines, second stage	
01.2.6	Arrow lines for marking of views, cuts and sections	
01.2.7	Proposed contours on landscape drawings	

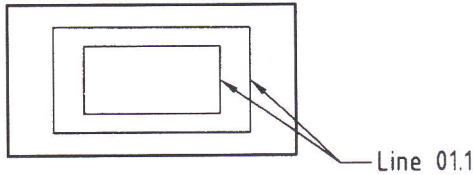
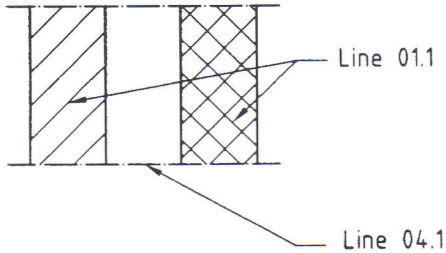
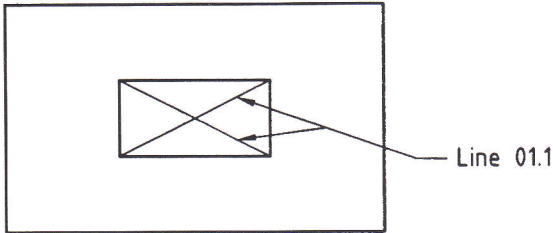
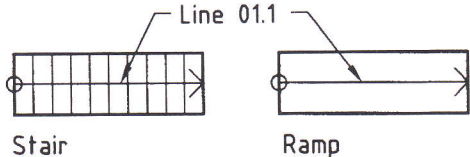
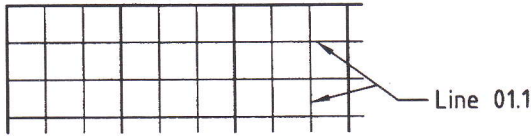
Table A.1 (continued)

No.	Line type	Example of application
01.3	Continuous extra-wide line	
01.3.1	Visible outlines of parts in cut and section when hatching is not used	 <p style="text-align: center;">Vertical section of a wall</p>
01.3.2	Reinforcing bars	
02.1	Dashed narrow line	
02.1.1	Existing contours on landscape drawings (alternatively, see 01.1.10)	
02.1.2	Subdivision of plant beds/grass	
02.2	Dashed wide line	
02.2.1	Hidden outlines	
02.3	Dashed extra-wide line	
02.3.1	Reinforcing bars in bottom layer on plan and far face layer in elevation when bottom and top layers are shown on the same sketch	

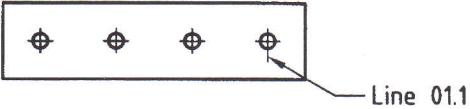
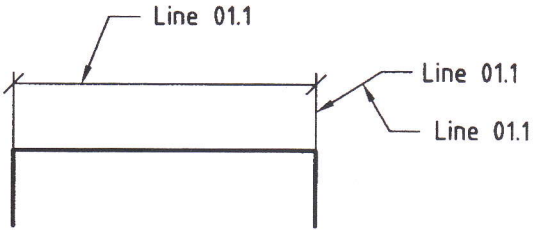
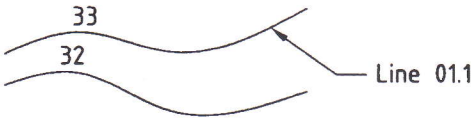
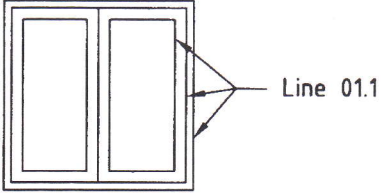
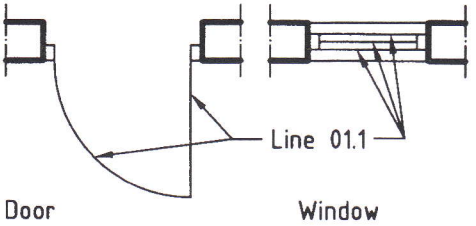
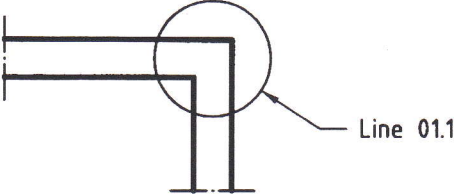
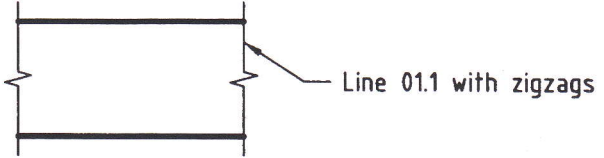
Table A.1 (continued)

No.	Line type	Example of application
04.1	Long dashed dotted narrow line	
04.1.1	Cutting planes (drawn with line 04.2 at ends and changes of direction)	
04.1.2	Centrelines	
04.1.3	Lines of symmetry	
04.1.4	Framing of enlarged details	
04.1.5	Reference lines	
04.2	Long dashed dotted wide line	
04.2.1	Cutting planes (drawn with line 04.2 at ends and changes of direction; the rest is drawn with line 04.1)	

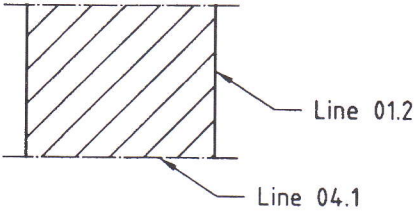
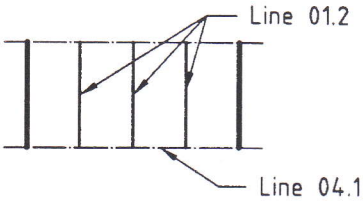
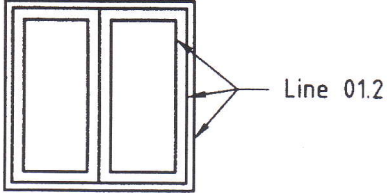
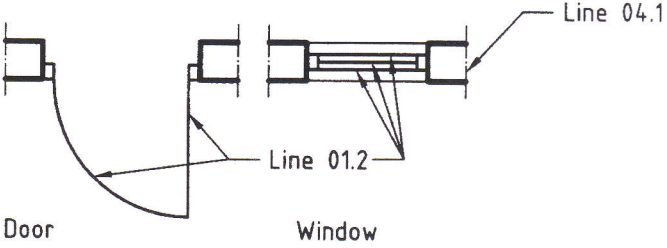
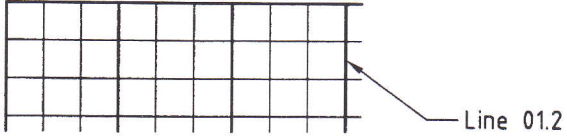
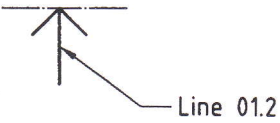
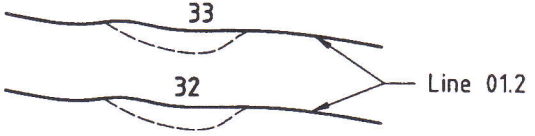
Table A.1 (continued)

No.	Line type	Example of application
04.2.2	Outlines of visible parts situated in front of the cutting plane	 <p>A technical drawing showing a horizontal beam supported by two columns. The beam and columns are drawn with solid lines. A cutting plane is indicated by a dashed line passing through the beam. The beam and columns are labeled 'Beam' and 'Column' respectively. The cutting plane is labeled 'Line 04.1'. The beam and columns are also labeled 'Line 04.2'.</p>
04.3	Long dashed dotted extra-wide line	
04.3.1	Secondary lines for setting out and arbitrary reference lines	 <p>A technical drawing showing a diamond shape on the left and a long dashed dotted line extending to the right. The diamond shape is labeled 'Line 01.1'. The long dashed dotted line is labeled 'Line 04.3'.</p>
04.3.2	Indication of lines or surfaces to which a special requirement applies	 <p>A technical drawing showing a cross-section of a beam. The beam is drawn with solid lines. A cutting plane is indicated by a dashed line passing through the beam. The beam is labeled 'Line 04.1'. The cutting plane is labeled 'Line 04.3'.</p>
04.3.3	Boundary lines for contracts, stages, zones, etc.	 <p>A technical drawing showing a site plan. The site plan is drawn with solid lines. A boundary line is indicated by a long dashed dotted line. The boundary line is labeled 'Line 04.3'. The site plan is labeled 'Site plan'.</p>
05.1	Long dashed double-dotted narrow line	
05.1.1	Alternative and extreme position of movable parts	 <p>A technical drawing showing a rectangular part with two small rectangular protrusions on its sides. The part is drawn with solid lines. A cutting plane is indicated by a dashed line passing through the part. The part is labeled 'Line 04.1'. The cutting plane is labeled 'Line 05.1'.</p>
05.1.2	Centroidal lines	 <p>A technical drawing showing a cross-section of a beam. The beam is drawn with solid lines. A cutting plane is indicated by a dashed line passing through the beam. The beam is labeled 'Line 04.1'. The cutting plane is labeled 'Line 05.1'.</p>
05.1.3	Outlines of adjacent parts	 <p>A technical drawing showing two adjacent rectangular parts. The parts are drawn with solid lines. A cutting plane is indicated by a dashed line passing through the parts. The parts are labeled 'Line 04.1'. The cutting plane is labeled 'Line 05.1'.</p>

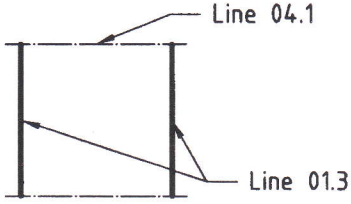
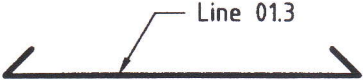
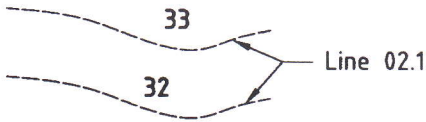
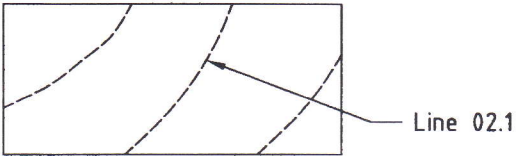
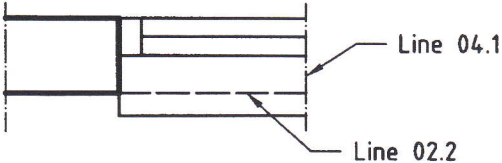
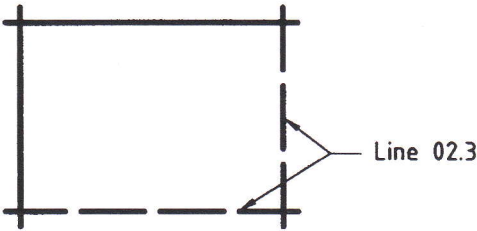
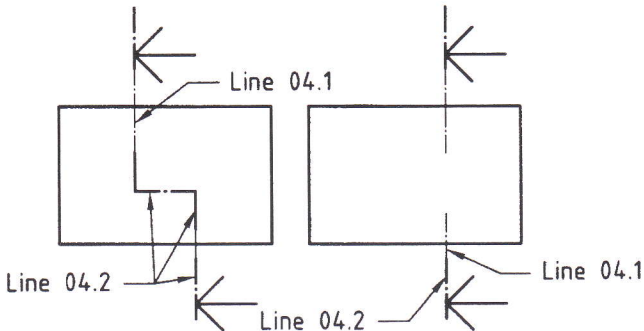
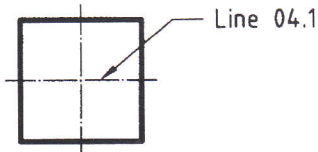
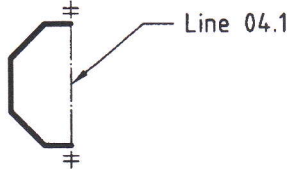
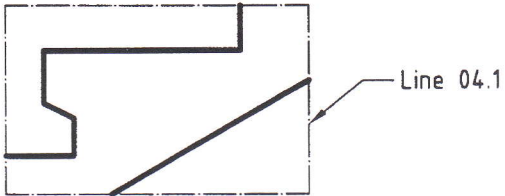
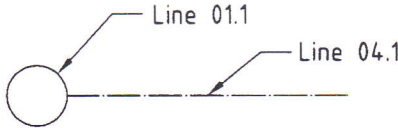
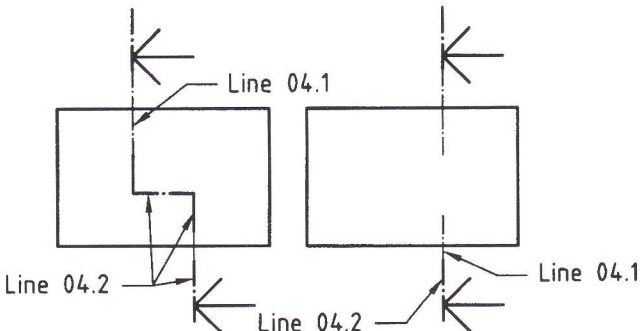
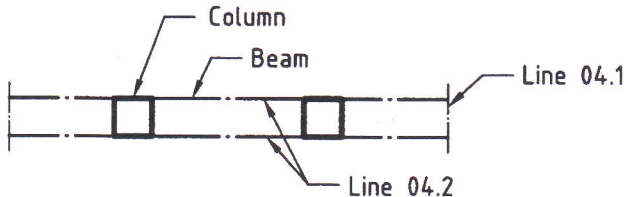
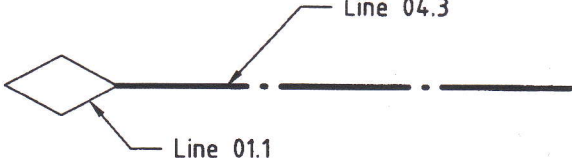
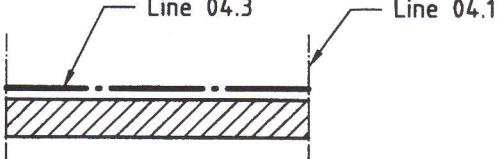
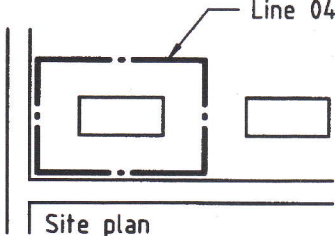
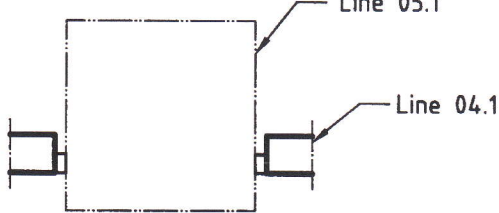
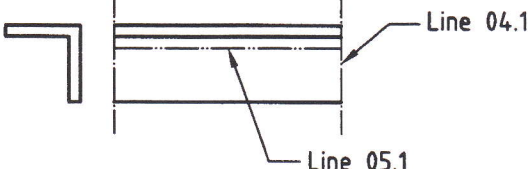
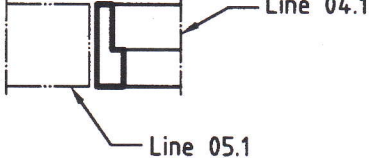
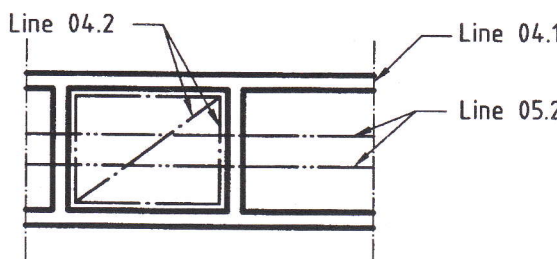
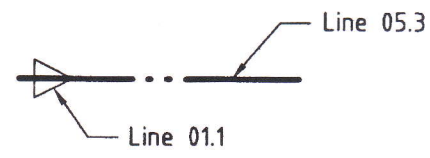
Table A.1 (continued)

No.	Line type	Example of application
05.2	Long dashed double-dotted wide line	
05.2.1	Outlines of hidden parts situated in front of the cutting plane	
05.3	Long dashed double-dotted extra-wide line	
05.3.1	Reinforcing prestressed bars and cables	
07	Dotted narrow line	
07.1	Outlines of parts not included in the project	